



# Science in Action: Christian and Skylar

Reader



## THIS BOOK IS THE PROPERTY OF:

STATE \_\_\_\_\_

PROVINCE \_\_\_\_\_

COUNTY \_\_\_\_\_

PARISH \_\_\_\_\_

SCHOOL DISTRICT \_\_\_\_\_

OTHER \_\_\_\_\_

Book No. \_\_\_\_\_

Enter information  
in spaces  
to the left as  
instructed.

		<b>CONDITION</b>	
		<b>ISSUED</b>	<b>RETURNED</b>
<i>ISSUED TO</i>	<i>Year Used</i>		
.....	.....		
.....	.....		
.....	.....		
.....	.....		
.....	.....		
.....	.....		
.....	.....		
.....	.....		
.....	.....		

PUPILS to whom this textbook is issued must not write on any page or mark any part of it in any way, consumable textbooks excepted.

1. Teachers should see that the pupil's name is clearly written in ink in the spaces above in every book issued.
2. The following terms should be used in recording the condition of the book:  
New; Good; Fair; Poor; Bad.

# Science in Action: Christian and Skylar



Core Knowledge

## Creative Commons Licensing

This work is licensed under a Creative Commons Attribution-NonCommercial-ShareAlike 4.0 International License.



### You are free:

- to Share**—to copy, distribute, and transmit the work
- to Remix**—to adapt the work

### Under the following conditions:

**Attribution**—You must attribute the work in the following manner:

*This work is based on an original work of the Core Knowledge® Foundation ([www.coreknowledge.org](http://www.coreknowledge.org)) made available through licensing under a Creative Commons Attribution-NonCommercial-ShareAlike 4.0 International License. This does not in any way imply that the Core Knowledge Foundation endorses this work.*

**Noncommercial**—You may not use this work for commercial purposes.

**Share Alike**—If you alter, transform, or build upon this work, you may distribute the resulting work only under the same or similar license to this one.

### With the understanding that:

For any reuse or distribution, you must make clear to others the license terms of this work. The best way to do this is with a link to this web page:

<https://creativecommons.org/licenses/by-nc-sa/4.0/>

Copyright © 2025 Core Knowledge Foundation

[www.coreknowledge.org](http://www.coreknowledge.org)

All Rights Reserved.

Core Knowledge®, Core Knowledge Curriculum Series™, Core Knowledge Science™, and CKSci™ are trademarks of the Core Knowledge Foundation.

Trademarks and trade names are shown in this book strictly for illustrative and educational purposes and are the property of their respective owners. References herein should not be regarded as affecting the validity of said trademarks and trade names.

ISBN: 979-8-88970-566-6

An aerial photograph of a university campus, showing several large, multi-story brick buildings with gabled roofs and numerous windows. The campus is surrounded by green trees and walkways. A semi-transparent red rectangular box is overlaid on the center of the image, containing the title and table of contents.

# Science in Action: Christian and Skylar

## Table of Contents

Chapter 1	<b>A Little Brother's Problem</b> .....	2
Chapter 2	<b>Christian Yamada: Becoming an Engineer</b> ...	12
Chapter 3	<b>Problem Solved!</b> .....	24
Chapter 4	<b>Skylar Neilsen: Learning to Be an Engineer</b> ..	34

# A Little Brother's Problem

## Chapter

# 1

Nine-year-old Christian carried two bowls of snacks into his family's living room. One bowl held a salty-sour dried fruit called *crack seed*. Hawaiians like Christian call it *see moi*. The other had spicy-crunchy rice crackers.



Christian's two older brothers, Andrew and Zach, were sprawled across the large couch facing the TV.

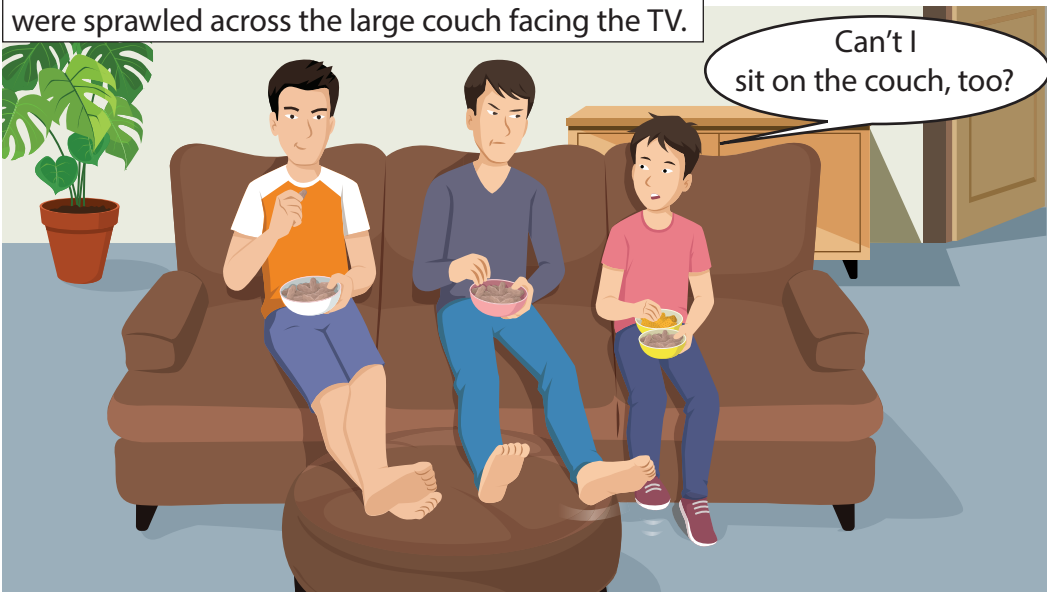

The teenagers moved over slowly to make room for him. But each time Christian tried to put his feet up on the single **ottoman** in front of the couch, his big brother Andrew nudged his feet off.

Annoyed, Christian tried his best to enjoy the football game. He and his brothers cheered as the Hawaii Rainbow Warriors won the game.

As the Rainbow Warriors made each touchdown, Christian and his brothers stood up and cheered. Each time he sat down, Christian tried to sneak his feet onto the ottoman alongside his brothers'. Each time, Andrew kicked off his feet.



Next time we watch a game, I want to put my feet up, too. How am I going to make that happen?



A few days later, Christian hung out after school with his cousin Kai. They talked about the football game.

It was fun to watch with Andrew, except he would not share the ottoman with me.

How am I going to solve this **problem**?

Nah, it would take me more than a year to save enough money.

I could tell my parents Andrew is being mean and ask them to buy a new ottoman just for me.

Maybe I could build an ottoman.

I get it.

You could buy your own ottoman with your allowance money.

Wouldn't they tell you to just get along better with him?



The boys went into Christian's living room and looked at the ottoman in front of the couch.

Does it have to be round, like this one?

Does it need to be soft on top, like this one?

I don't think so. As long as I can rest my feet on it comfortably when watching a game, I'll be happy.

Yes. That will make it comfortable for resting my legs.



Let's see what we can find outside that I can use to make my ottoman.

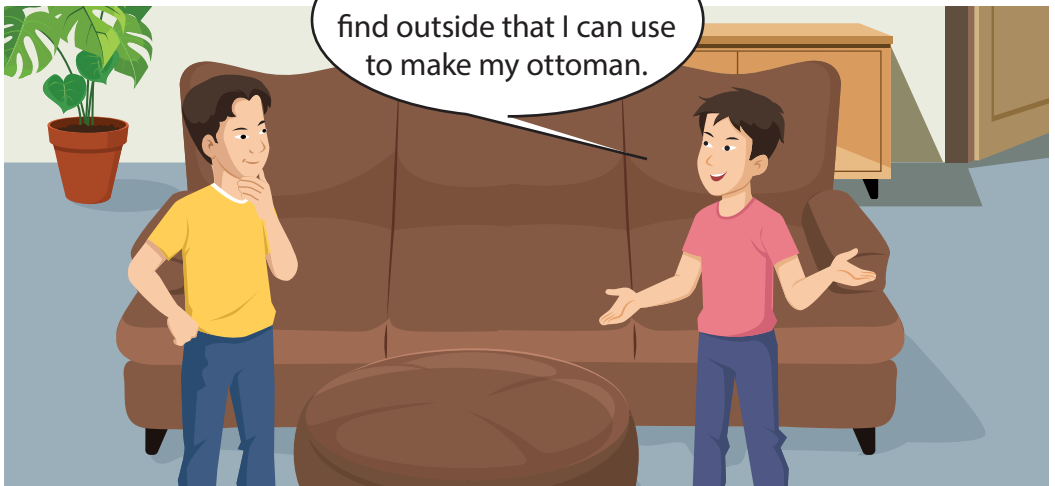

Christian found a tape measure and used it to measure the height of the family ottoman. The height was the most important measurement. If the ottoman is too high or too low, it will not be as comfortable. Christian's new ottoman needed to be done by next week.

The boys found some pieces of cardboard in a recycling bin. Christian arranged the cardboard in the shape of a box. He got a roll of masking tape from inside the house and used the tape to hold the pieces of cardboard together.



But when he tested what he made by putting his feet on top of the box, the box collapsed.



What do YOU think went wrong?

"I'm not giving up!" declared Christian. "Let's see what else we can use to solve the problem."

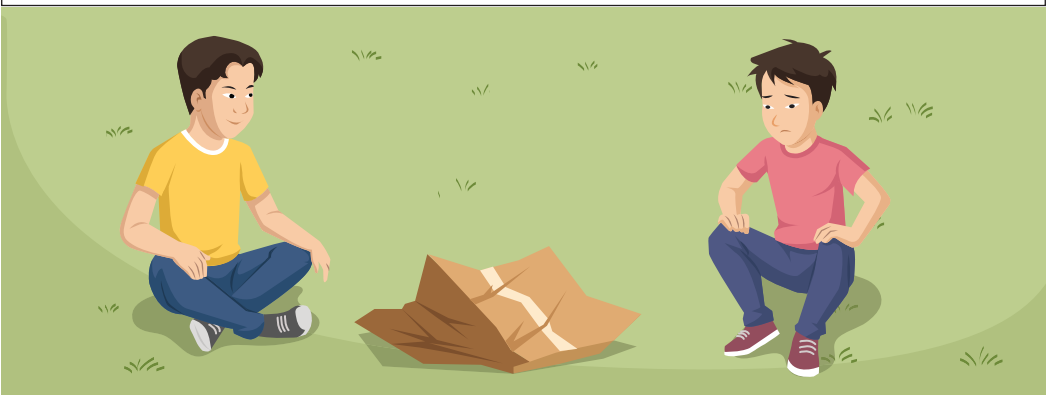

They looked around the yard. On the ground under a false koa were branches that had fallen from the tree. The boys looked at each other and started to gather the sticks.



What do YOU think they could use to hold the sticks together?

Christian reminded Kai of a family trip to a museum where a man demonstrated how to use cord made from plants to build a canoe. First, the man crossed one piece of wood over another. Then, he wrapped cord tightly around both pieces of wood. Called *lashing*, the cord held the pieces of wood together firmly.

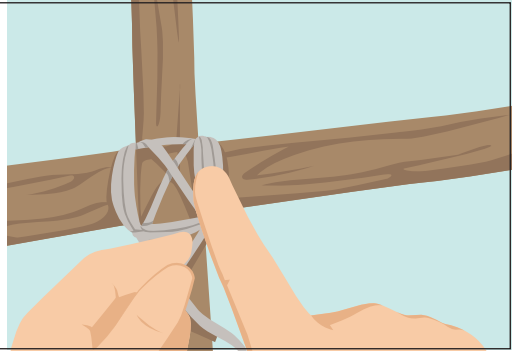

The man at the museum used cord he made from plants. I think we have a ball of string in the house that we can use to lash together the sticks for my ottoman.



Christian went inside the house to ask to use the ball of string.



What are you using it for?

I'm going to fix a problem my brothers caused.

As Kai held the ends of two false koa sticks together, Christian wrapped string around them to hold them in place. After connecting eight more pairs of sticks, he had formed a rectangular box.

That looks good and sturdy, but your legs are going to hurt resting on sticks. How will you make the top of your ottoman soft?

See those palm leaves that were blown down in the last storm? What if we weave them over the stick frame?



What do YOU think?  
Will it work?

The boys gathered the palm leaves and started to weave them in and out of the stick frame. Soon they had all the sides of the cube covered.

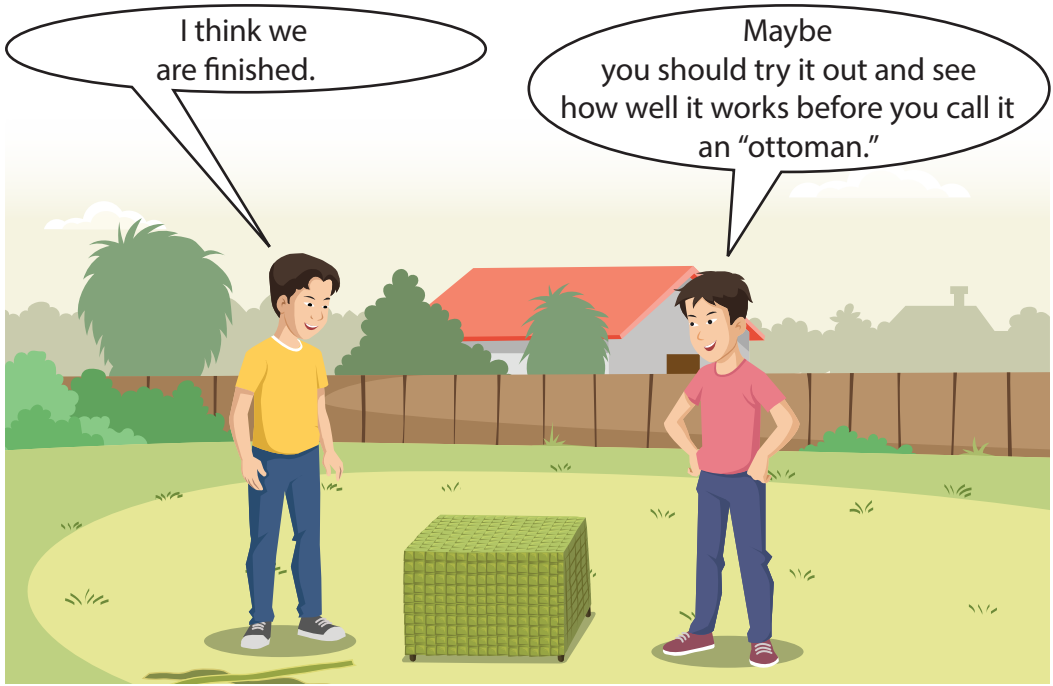

The cousins carried the object into Christian's living room and placed it in front of the couch. Christian sat down on the couch and put his legs up on the ottoman.

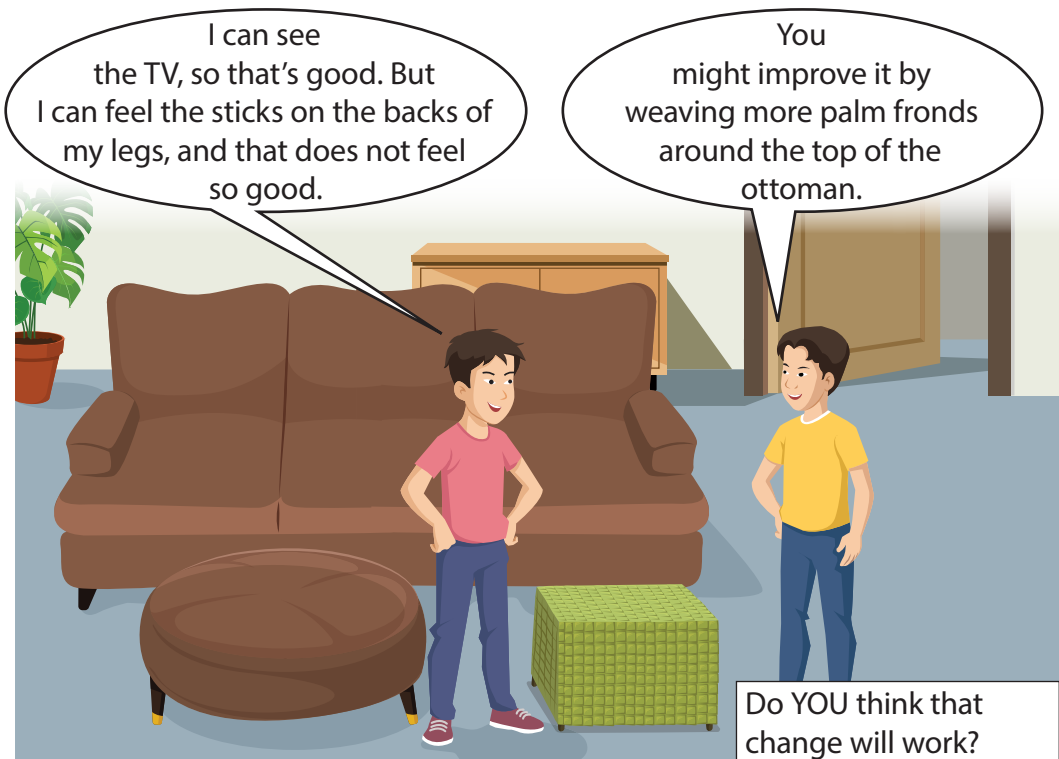

The next week, Christian's brothers sat down in their living room to watch the Hawaii Bowl football game.

Christian placed his see moi and rice cracker snacks on a table near the couch. Then he proudly carried in his homemade ottoman and placed it in front of his seat. His brothers looked at it, looked at each other, and grinned.

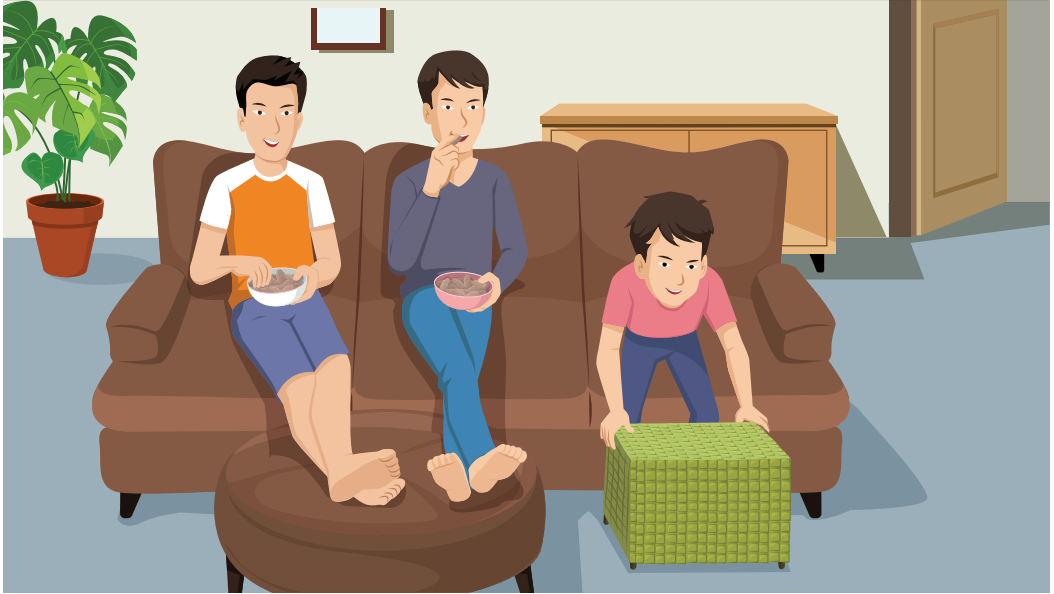

Christian, glad that he kept trying until he solved the problem, smiled and watched the Hawaii team defeat the Idaho team. He was quite comfortable with his feet up on his own ottoman!



# Christian Yamada: Becoming an Engineer

## Chapter

# 2

The story you read in Chapter 1 was about a nine-year-old named Christian. Christian is a real person who has two older brothers. He did grow up in Hawaii. And he does like to watch Hawaiian football teams with his brothers. It's also true that his brother wouldn't share the ottoman in their living room. Christian really did solve the problem by building his own ottoman!



An **engineer** is someone who is trained to use math and science to solve problems and meet the needs of humans.

Christian's brother Andrew is six years older than he. When Christian was in middle school, Andrew went off to college. He studied to become an electrical engineer. Electrical engineers design systems and machines that use electricity. Christian was **inspired** by seeing his brother do well as an engineer.

Now Christian is nineteen years old. When it was time to find a college, he chose to travel across the ocean and North America to New York. His college is called RPI—Rensselaer Polytechnic Institute.

Christian is an Engineering Ambassador at RPI. He gives talks at middle schools to inspire kids to become engineers.



At college, Christian is learning how to become a **mechanical engineer**. He says, "I think of mechanical engineering as using my understanding of invisible things, like electricity, to make things you can see, like machines."

What is it like at an engineering college? You can live on campus with other students. Most new students live together in apartment-like buildings. You can eat all your meals on campus, too. There are many different kinds of foods to choose from.



When you live on campus, you can walk to classes and do homework between classes. Many of your classes will be in math and science.



When you are not doing homework, you can join clubs that meet your interests. There are clubs for playing sports, singing, dancing, making photos, and even fishing at Christian's college. And if you want to learn how to cook, there is a club for that, too!



If you are a musician, you can perform music with other students. Christian plays the cello in his college orchestra.





Christian learned how to work in a clean room at college. He explains that it is like going into a hospital operating room. This means there is no dust, germs, or other particles in the air or on surfaces. To enter the clean room, Christian has to put on equipment that protects him and the products made there. These can include gloves, gowns, hair caps, masks, and goggles.



How do engineers figure out how to make a clean room? They use an engineering design process. You can see the steps in the picture. The double arrows show that the steps can happen in any order and can be repeated.

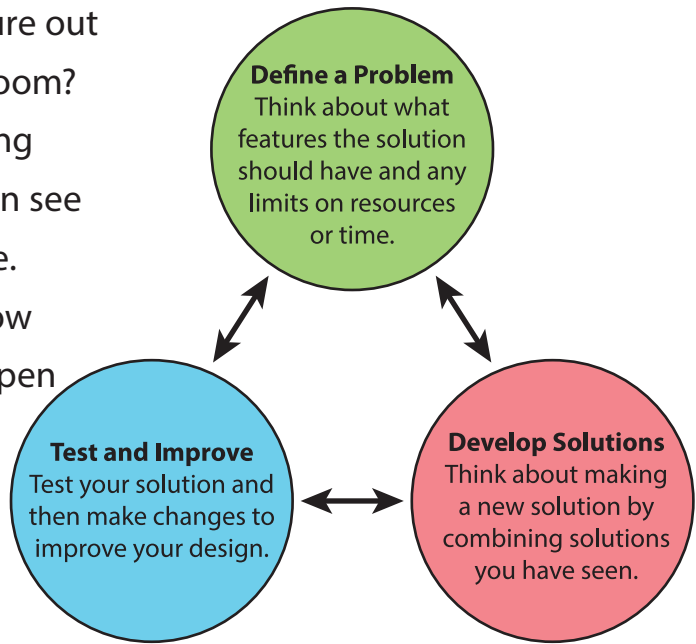

Anyone can use this process. Let's say you want to invent a model robot. What do you want the robot to do? What materials do you have on hand? How much time do you have to finish your robot? Once you answer these questions, you can think about different ways to make the robot. When you have made a model, you can test how it works. If it doesn't work, you can try building it another way. Or you can define a new problem, changing what you expect the robot to do.

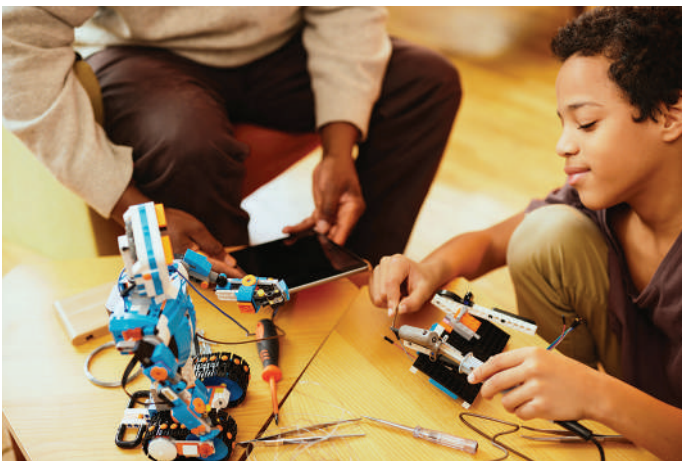

Most of all, don't give up. Inventors' ideas don't usually work the first time they are tried.

Engineering students practice becoming **inventors**. Christian was paired with a student studying business on one project. They were challenged by their teacher to design a greenhouse that can run itself.

Do you like to eat fresh lettuce and tomatoes in the winter? In many places, winters are too cold to grow vegetables like these. That's when farmers grow crops in greenhouses. A greenhouse keeps the air inside warm and has the lighting needed to grow fruits and vegetables when it is cold outside. But it takes a lot of electrical energy. Christian and his partner tried to design a greenhouse that used no electrical energy. One solution was to add materials inside the greenhouse that act like reusable hand warmers.

Greenhouses have another problem. The lights and heaters stop working when there is a power failure. One solution is to use solar cells as a source of electrical energy.



Engineers solve all kinds of problems that help people. What kinds of work can engineers do? Here are just a few examples.

**Civil engineers** design the infrastructure humans use to live, such as roads, buildings, bridges, and tunnels.



### **Materials engineers**

test materials such as the metals and plastics used in computers, jets, and sports equipment.

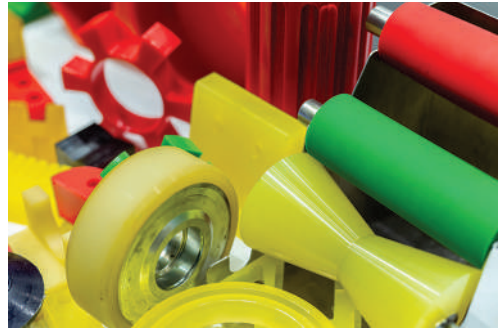

**Mechanical engineers** design or improve machines, such as cars, refrigerators, and elevators.

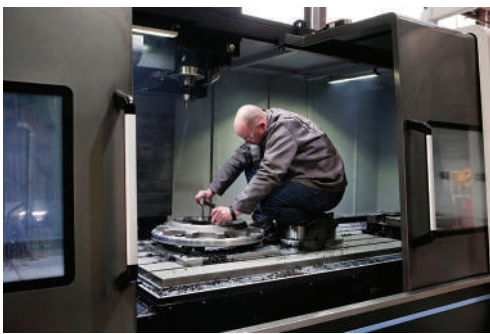

**Computer engineers** design hardware like computers and software such as the programs that run the computers.

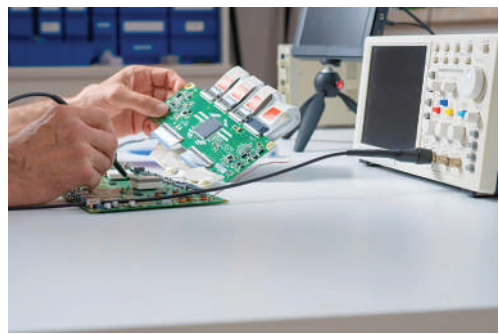

Christian wanted to become a mechanical engineer because they are needed in all kinds of jobs, from making microwave ovens to building spaceships. "So that's why I chose it—because it gave me a lot more options and I was able to learn a little bit of everything."

A **patent** is a written statement giving the inventor the right to stop other people from copying an invention.

Some students study engineering but do not become designers or inventors. Instead, they use their knowledge of math, science, and design in other careers. For example, after finishing engineering college, they can become patent lawyers.

Inventors can sometimes earn money by selling their inventions. The first step is getting a patent for their invention. A patent protects the hard work inventors do.

If Christian were to become a patent lawyer, he could help inventors protect their rights. He would use his understanding of engineering to help inventors get patents.

Here's a drawing from a 100-year-old patent. What did the inventor design that was new and different?

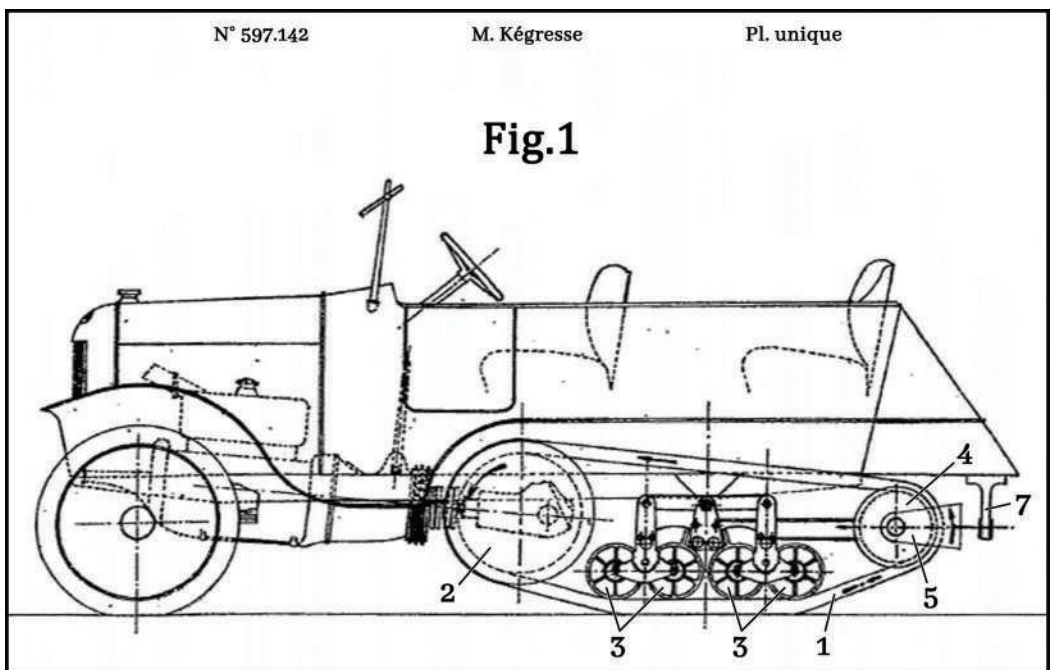

# Inspired by . . .

To be **inspired** by someone means they made us want to try something.

Christian Yamada was inspired to get into engineering by **Steve Wozniak**.

**Born** in 1950, in California

**Childhood Interests . . .** Building radios and calculators, watching *Star Trek* on TV

**Famous for . . .**

Wozniak invented the first computers that people could buy, take home, and use right away for work or fun. Before then, computers could only be found in colleges, businesses, or government offices. He and another Steve—Steve Jobs—started a company to build computers when he was about twenty years old. That company was Apple Computer.

**Words of Wisdom . . .**

“[I] hope you’ll be as lucky as I am. The world needs inventors—great ones. You can be one. If you love what you do and are willing to do what it takes, it’s within your reach. And it’ll be worth every minute you spend alone at night, thinking and thinking about what it is you want to design or build. It’ll be worth it, I promise.”





In 1975, Steve Wozniak invented the personal computer at night and on weekends. That is because he had a day job designing calculators. More than fifty years earlier, in 1921, another engineer invented a calculator. Her name was **Edith Clarke**.

**Born** in 1883, in Maryland

**Childhood Interests . . .** Solving math problems and playing card games

**Famous for . . .**

Edith Clarke invented a tool named the Clarke Calculator. Her calculator was used to solve the difficult math problems needed to set up electrical power lines throughout North America. Clarke was the first woman to work as an electrical engineer in the United States. When she became a college teacher, she was the first woman professor of electrical engineering in the United States.

**Words of Wisdom . . .**

"There's always a demand for anyone who can do a good piece of work."

# Problem Solved!

## Chapter

# 3

Mom, I have been thinking about what kind of work I want to do when I grow up. I really love math, so I think I should be an accountant.

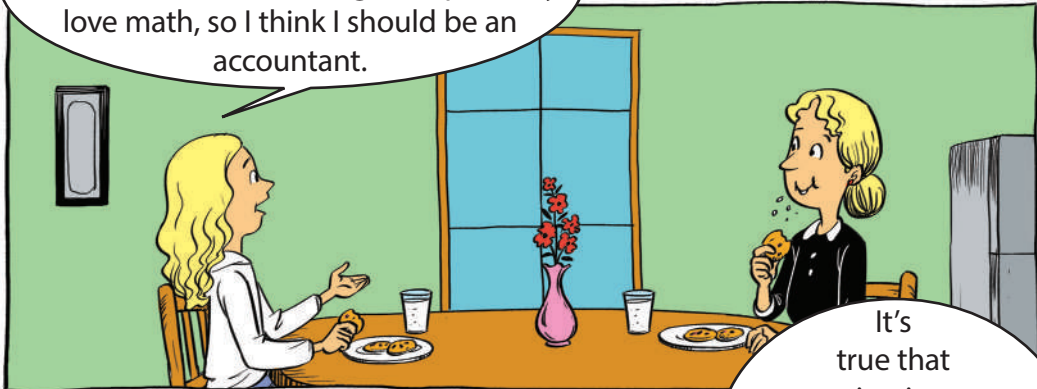

It's true that accounting is a career in which you use math. Accountants help people keep track of their money.



That sounds okay, but I like science, too. What other jobs are there for people who like math AND science?

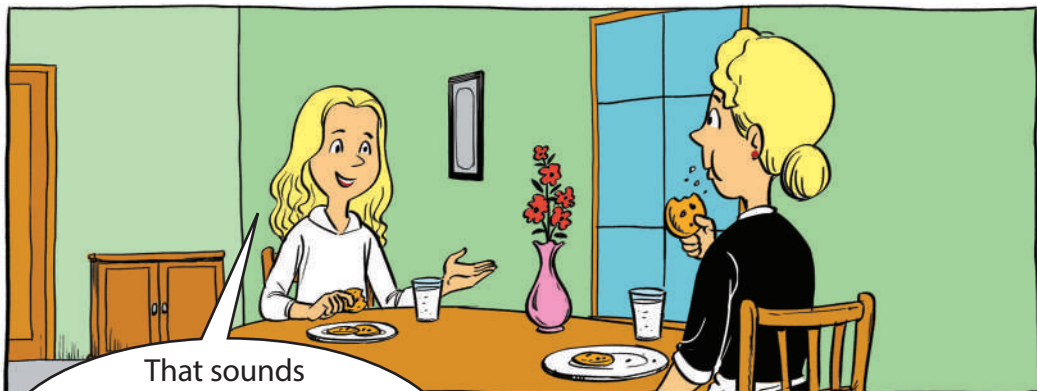

Maybe you should check out **engineering**. There are all sorts of engineers, but they all use math AND science in their work. Engineers solve problems that help people. Some design electric cars. Some code computers. Others design machines that allow injured people to move or speak.

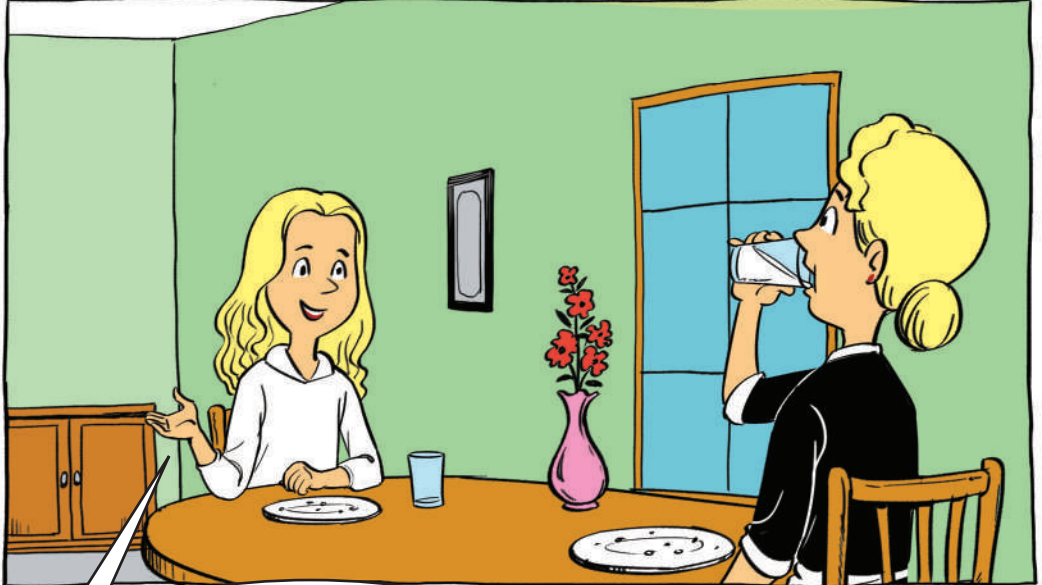
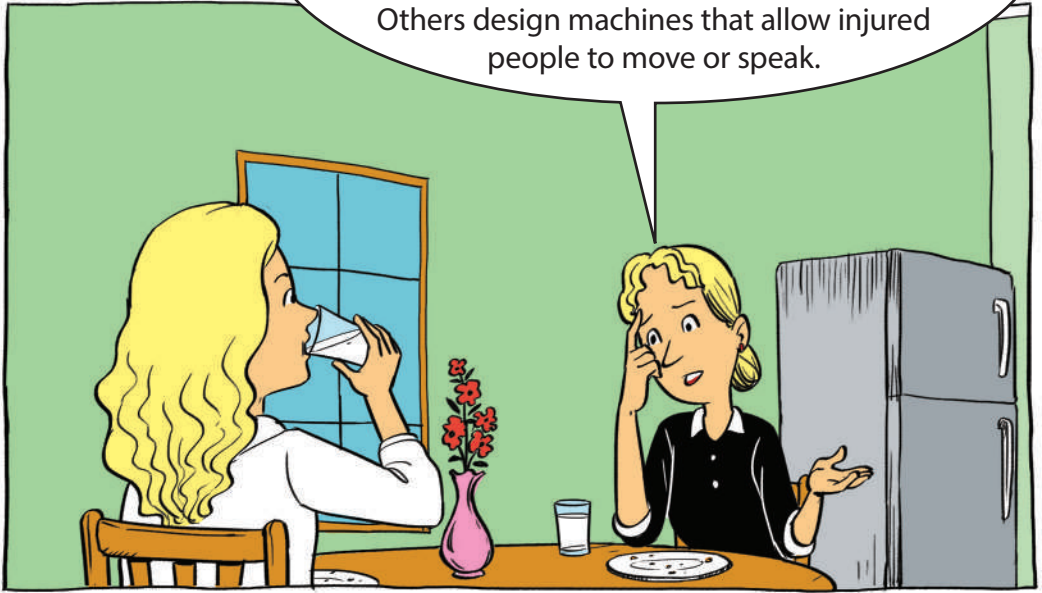

My teacher said we will soon be choosing classes to take next year in ninth grade. I'm going to sign up for an engineering class. That's the best way to find out if I like engineering.

Skylar was excited to begin high school. But she did not know what to expect in the physics class. She was surprised to learn that there was going to be a contest.

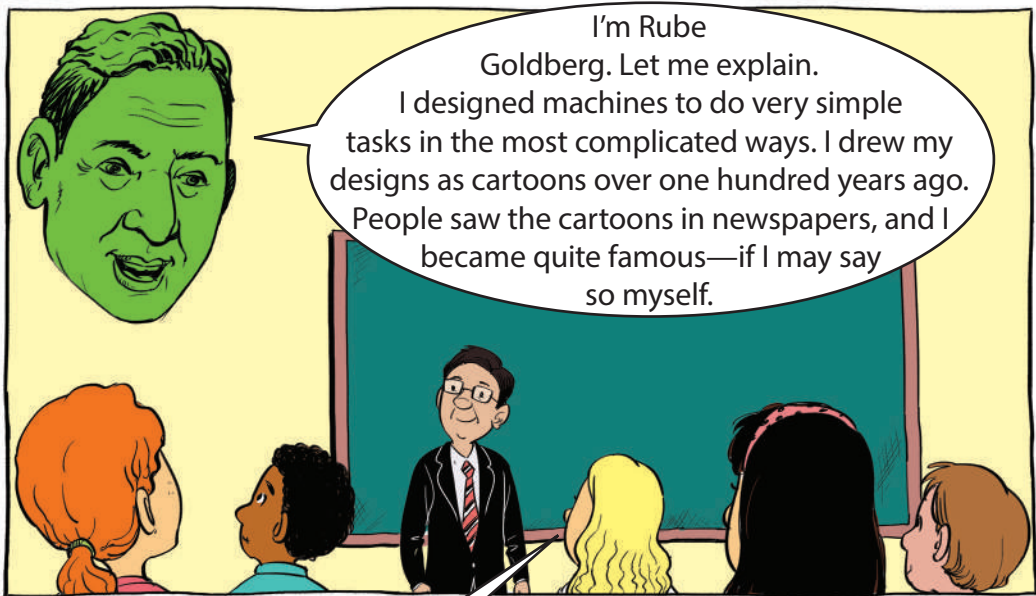
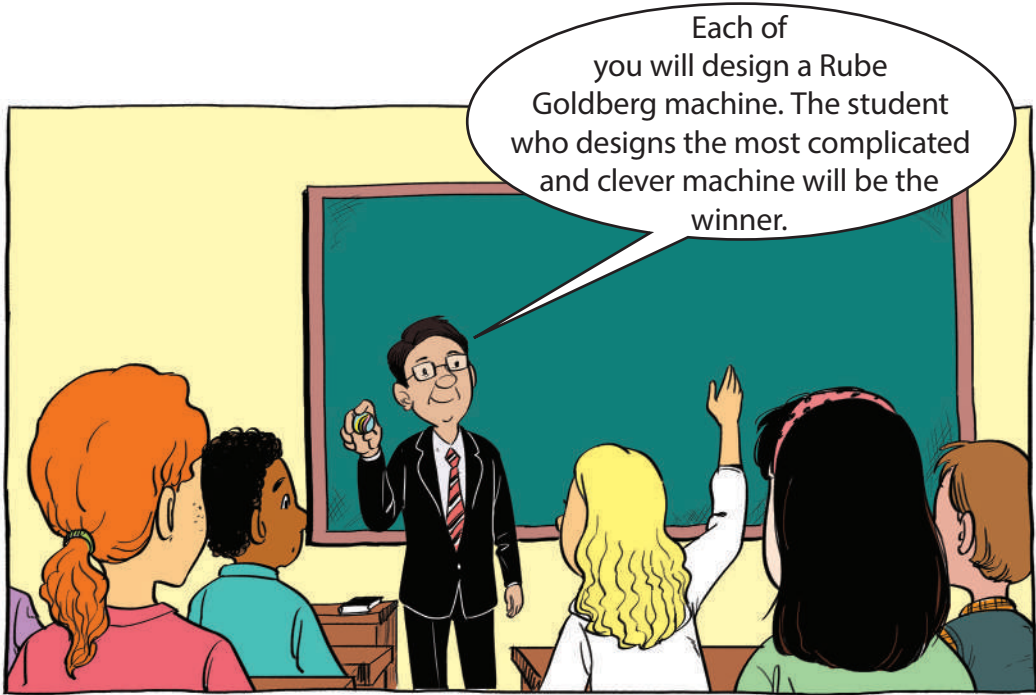

Who is Rube Goldberg? What does he have to do with this contest?

You will each have to use what you know about **forces** and objects in motion to design your machines. What do you know that might be useful?

Some forces are stronger than others. And each force pushes or pulls in one direction. We can use the patterns we see to predict what will happen in our machines.

When a moving object hits an object that is at rest, the object at rest may start moving.

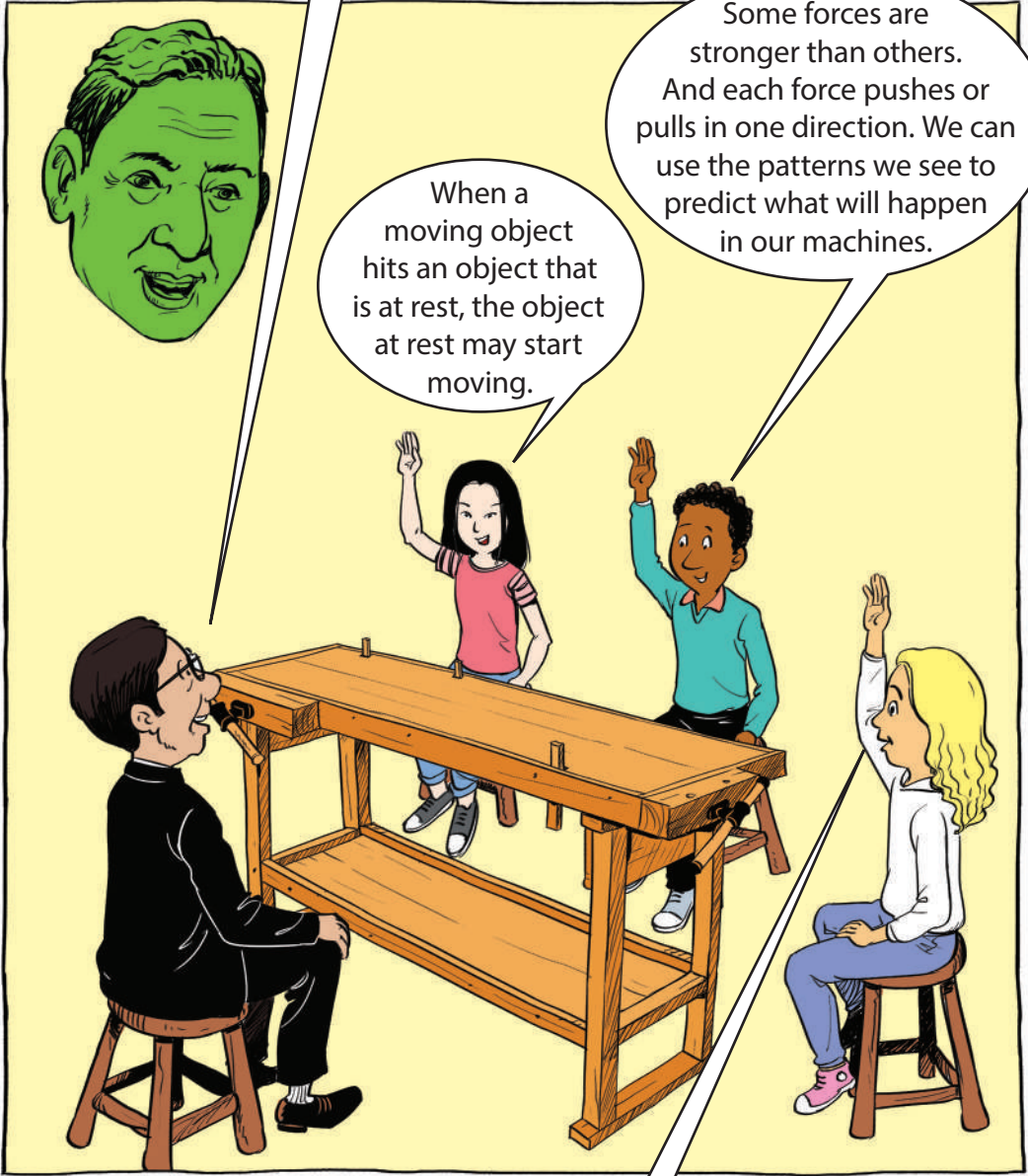

Forces are pushes and pulls. For example, **gravity** is a force that pulls objects down.

So, you will try to build a machine that uses forces and moving objects. Let me explain the problem in more detail. You have one week to solve the problem. You can only use the materials that are in this classroom or that you find around school. A marble must be one of them. You cannot buy anything. You have one week to come up with a solution.



I really, really want to win the contest. So, I'm going to make my machine crazy complicated. I'll have to come to school early and stay late, but it will be worth it.



I drew my designs as comics, but I never actually built them. Skylar, you'll have to solve the problem using real objects and make them work together.

Skylar looked around the room for materials she could use. She found some books on a shelf. She grabbed a cardboard tube from the recycling bin.

If I pile up these books, I can place the end of a cardboard tube on top. When I put the marble in the high end of the tube, gravity will pull it down, and it will roll through the tube. Mr. Ortiz, where can I build my machine?

Well, Skylar, how big is it going to be when you are done? Look at all the materials you will use and estimate how long and wide the table needs to be.



Next, Skylar found a box of dominoes, some pulleys, string, another marble, and a toy car.

I'll set up these dominoes in an S-shaped line near the lower end of the tube. The marble will knock over the first domino. Then, the others should fall over one by one.

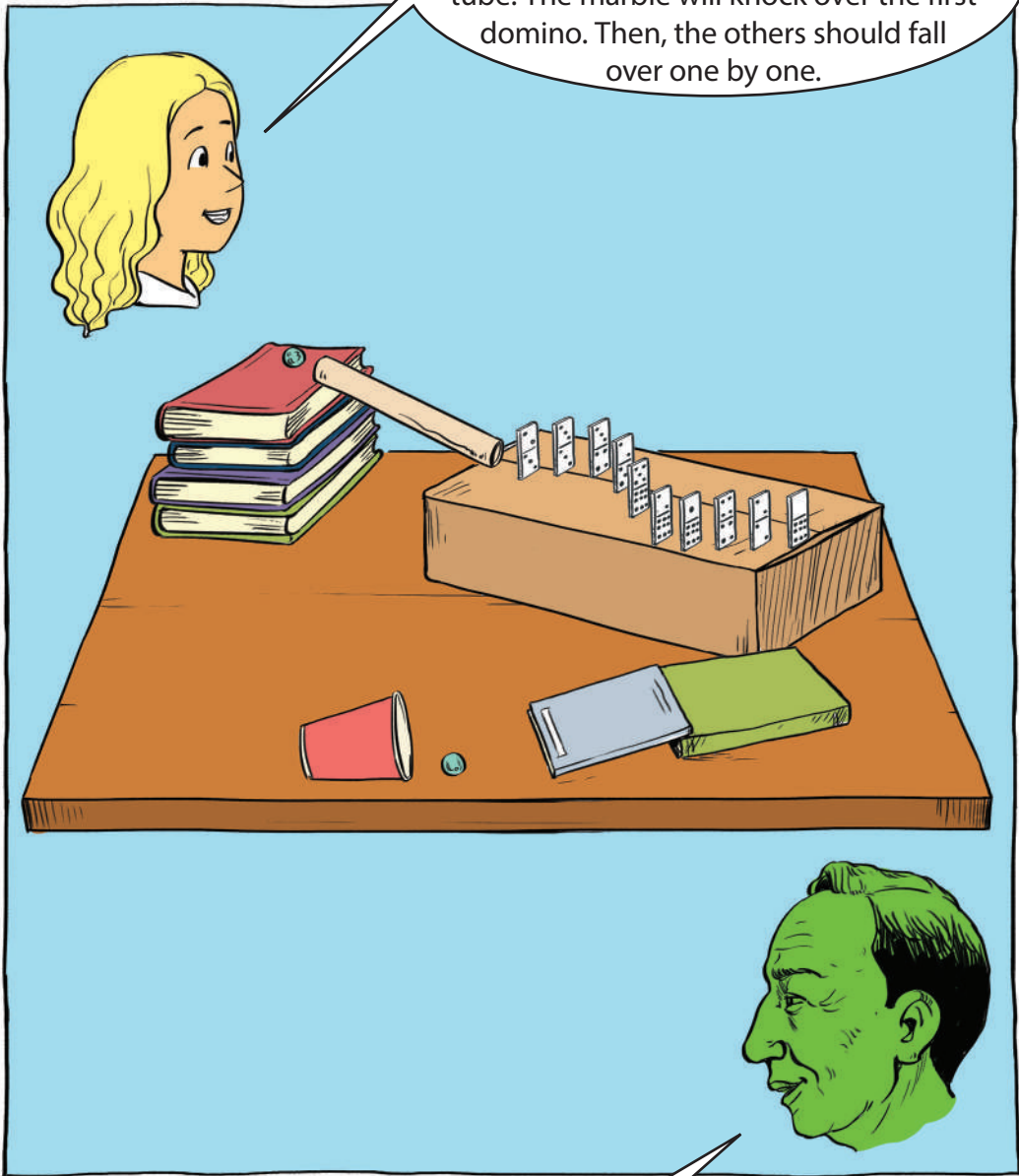

I cannot wait to see how you will set up the pulleys and car. Your design will soon be as complicated as one of mine!

I've got each part of my machine set up. The last domino hits a second marble that will roll forward into a basket. The basket will go down and release the car. The car will roll down the ramp and push the marble into the cup. I already tested it. But it didn't work at first.

I'll raise the height of the ramp so that the car moves faster and has more force. Then, I'll test it again.

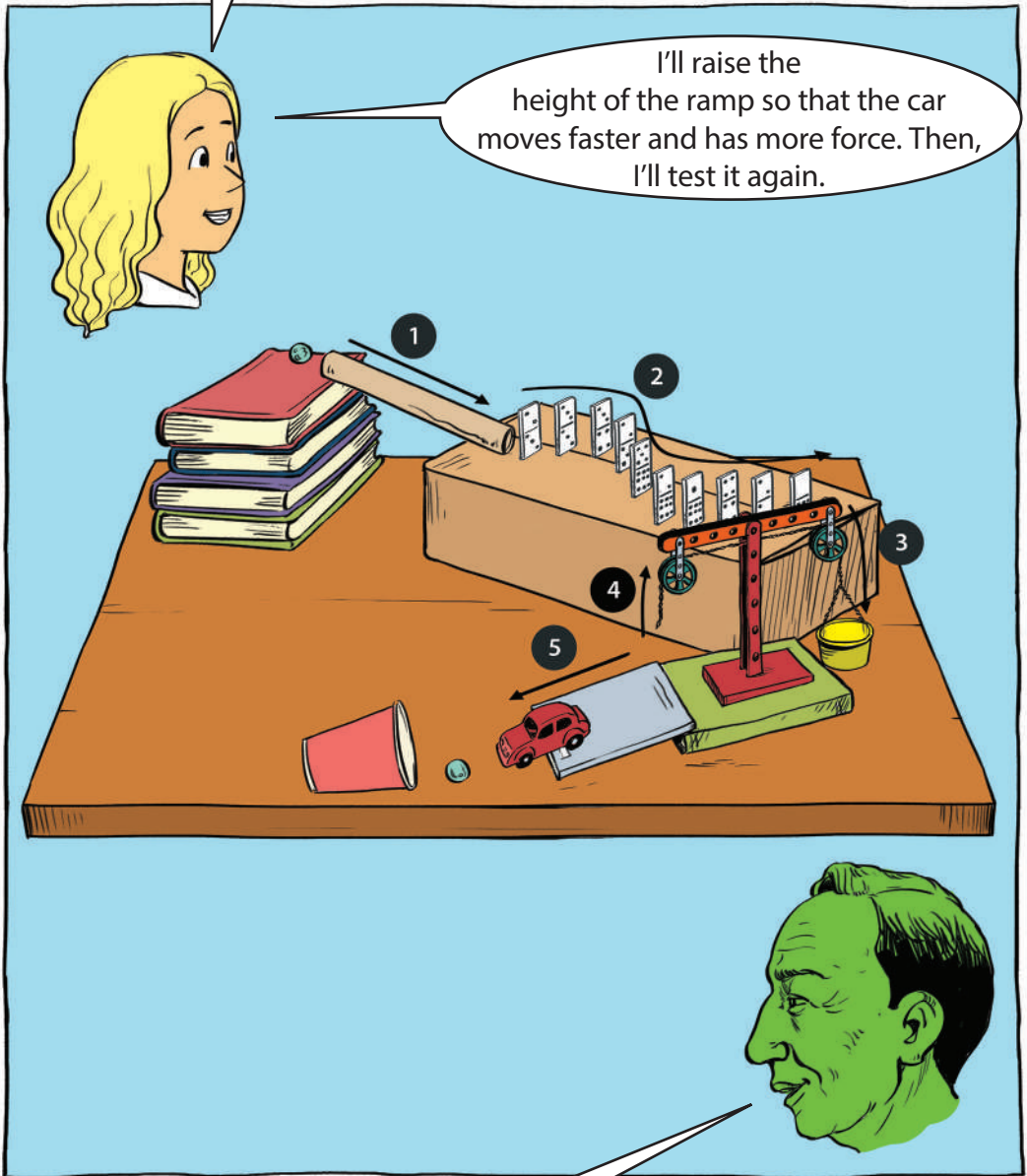

Uh-oh. The rolling car does not have enough force to push the marble into the cup. What can you do?

I'm ready for you to view my machine. I've tested my machine, and it is ready to go. I call it the Rube Goldberg and Skylar Machine.

Start your machine, Skylar, while I stand to the side of the table.

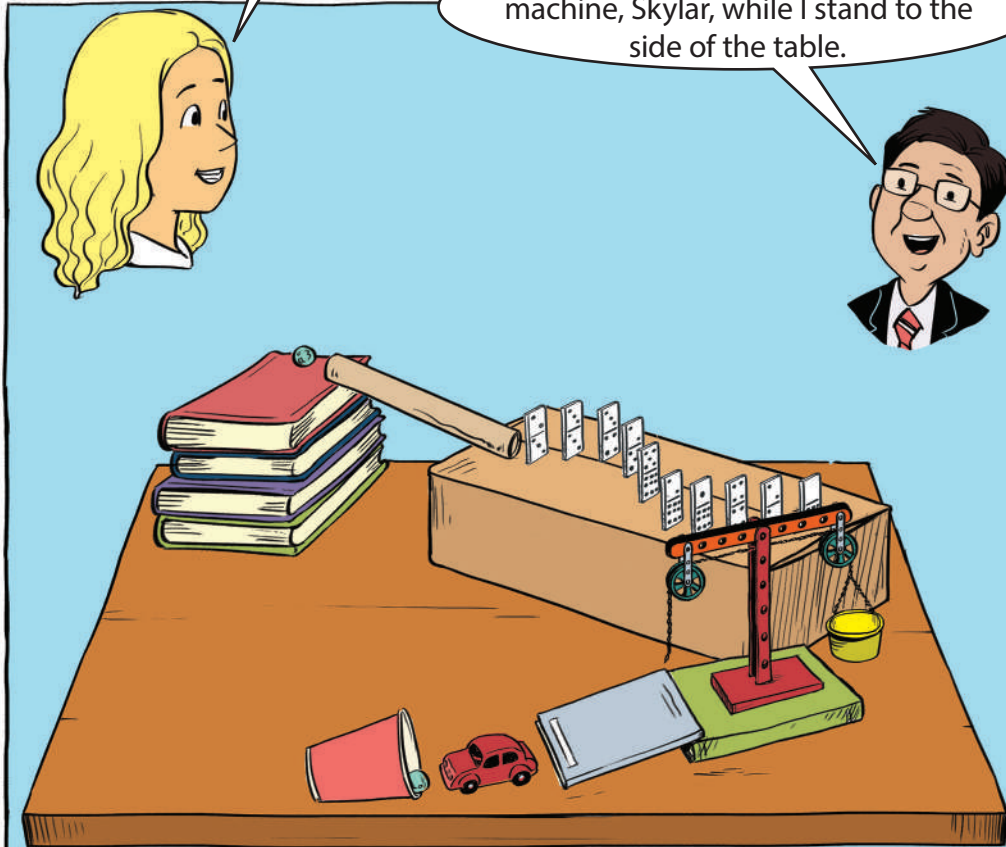

So, Skylar placed one marble back in the first tube and let it go. The force of the moving marble knocked over the dominoes. The pulley lifted. The toy car rolled down a ramp and bumped the marble. Then the marble was pushed into the cup.

I do declare! That certainly is a complicated way to move a marble!

That evening, Skylar told her mom about the Rube Goldberg machine she designed and tested in school.

The project was so much fun, even though I had to work really hard to solve the problem. I needed to use math AND science. And I've made my decision, Mom. Instead of being an accountant, I want to be an engineer.

You'll have to work hard to learn to be an engineer, but I know you can do it!

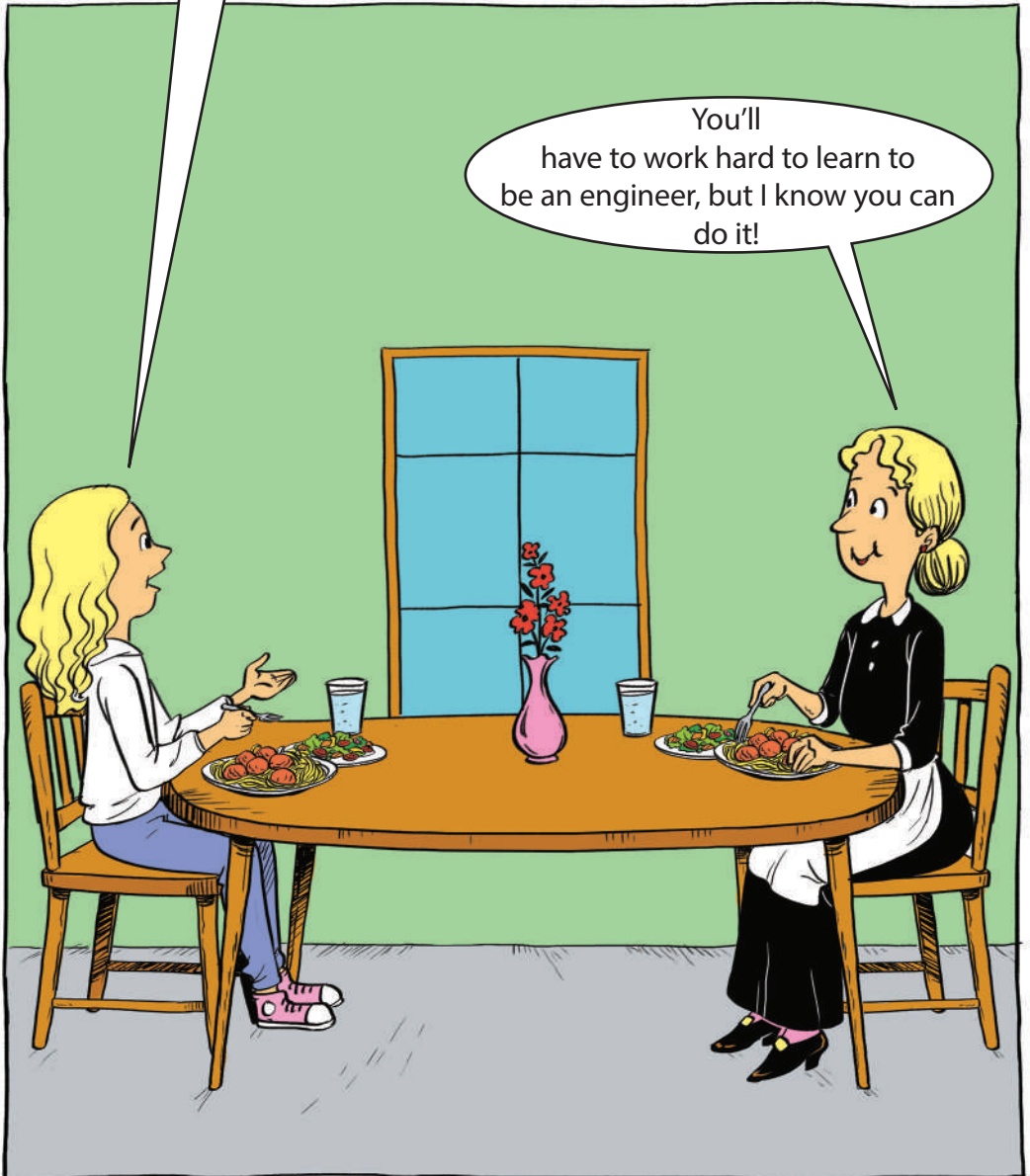

# Skylar Neilsen: Learning to Be an Engineer

Chapter

4

In Chapter 3, you read a story about a eighth grader named Skylar. Skylar is a real person, and she did build a Rube Goldberg machine in tenth grade. Rube Goldberg really was a famous cartoonist and inventor. But in the story, Skylar imagined that he was talking to her.

When Skylar was seven years old, she would watch her brothers play video games that involved building things. Soon she was playing alongside her brothers. Her brothers played around with computer equipment, too.

“I would watch, like, them and my dad build computers at home, which, like, I always thought was really interesting,” she says.



Skylar loved math and science, too. The summer before third grade, she memorized her times tables before school started. In fifth grade, she became very interested in learning about the human body. She asked her teacher what causes fingers to move when we want them to. When her teacher said that it just happens when we think about it, Skylar was perplexed.

“I definitely knew that it was, like, more difficult than that,” Skylar says with a smile.

**Try it yourself!** Look at photo showing how to sign the alphabet. Try to move your fingers to spell your name. How do you think your brain controls your fingers?

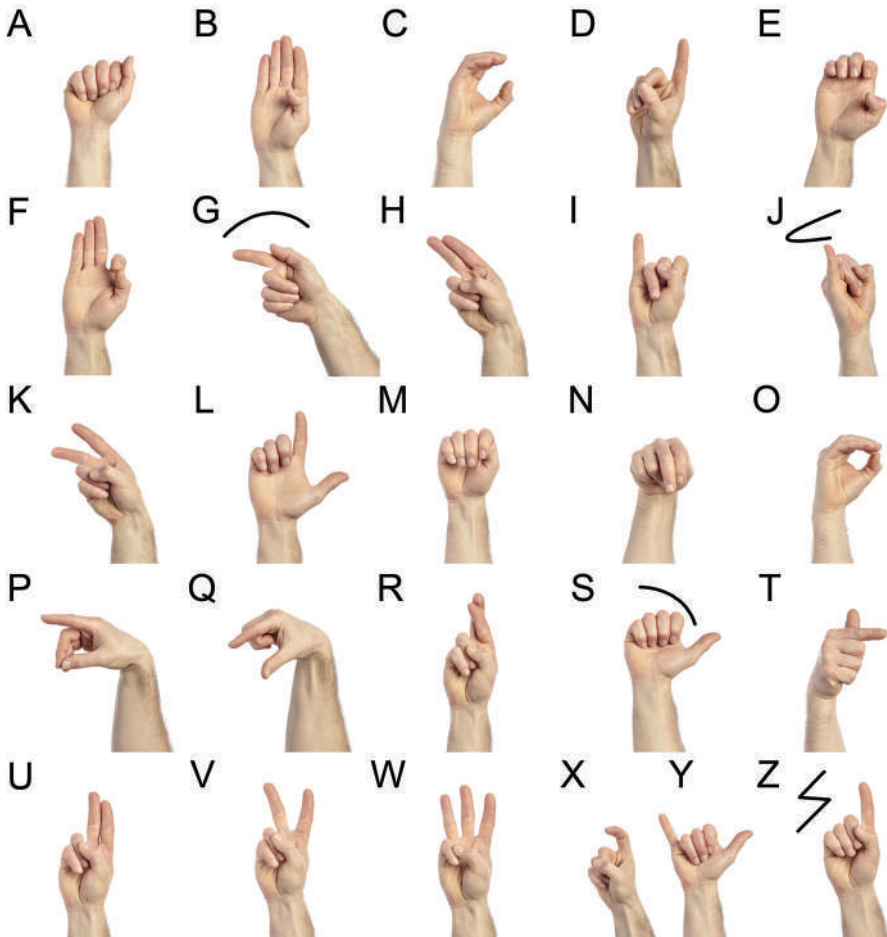

In ninth-grade science, Skylar and a classmate made a poster to show the parts of the human body that move blood. They also made a 3D paper model of the human heart.

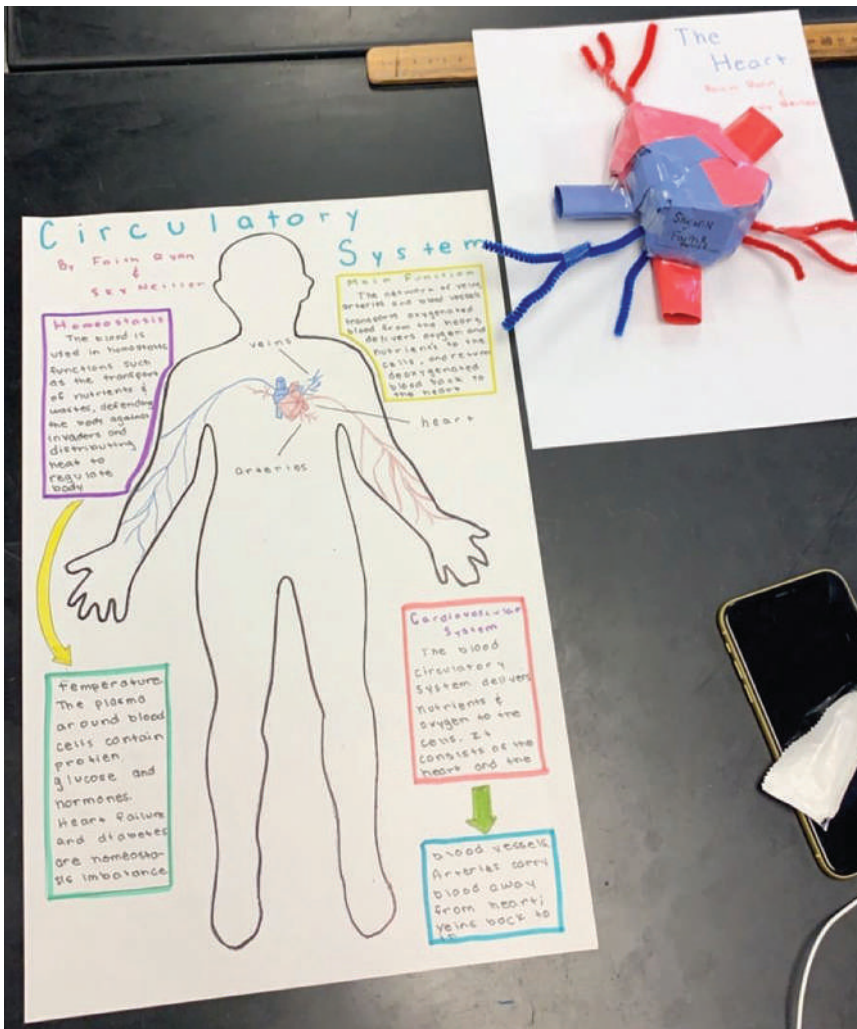

The next year, Skylar was in her first engineering class and learned about the possibility of 3D-printing body parts. The printers in your school or at home are probably 2D printers. The pictures of objects are printed on a flat surface. A 3D printer can build objects that have height as well as length and width. These printers use spray powders or liquids to build up something to look like a familiar object.

The idea of printing new body parts for people who need them sounded cool to Skylar. She realized that she wanted to help make that dream come true. The problem for engineers to solve is how to print body parts that are as alive as the rest of the human body.

Skylar asked questions and read about the problem. She learned that the kind of engineer who works on problems related to the human body is called a *biomedical engineer*. She could combine her interests in the science of the human body and solving problems by building things.

“I think high school was really what helped drive me towards engineering,” Skylar said as she thought about her life.

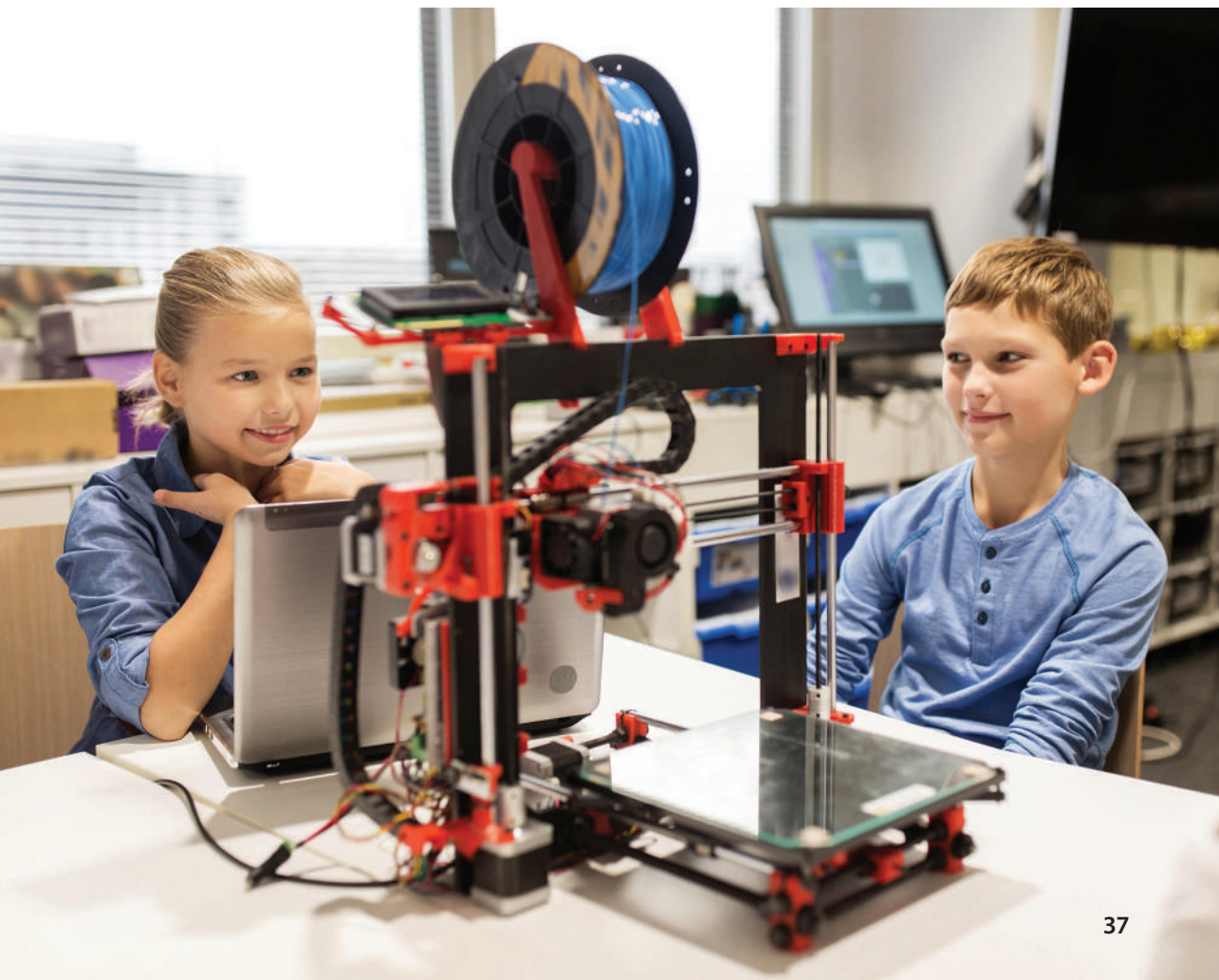

You read about the engineering process in Chapter 2. How did it work when Skylar made her Rube Goldberg machine? Her teacher defined the problem by saying what the machine should do. It had to push the marble into the cup. But it had to do it in the most complicated way possible. Mr. Ortiz also put limits on the solutions: the amount of time students could take and the materials they could use.

Once Skylar found materials, she began to develop solutions. She planned how the materials fit together, trying a few different ways. Then she tested her machine to see how the parts worked together.

Most solutions don't work the first time they are tested. Engineers expect that. When the toy car didn't push the marble into the cup, Skylar made changes until it worked.



To learn how the design process works, Skylar's class had to design cars using just pasta and glue. What do you think designing a car with just two things teaches you? What do you think the car would have to do?

**Try It Yourself!** Work with a small team to design your own car using just two materials. Draw your plan for a pasta car.

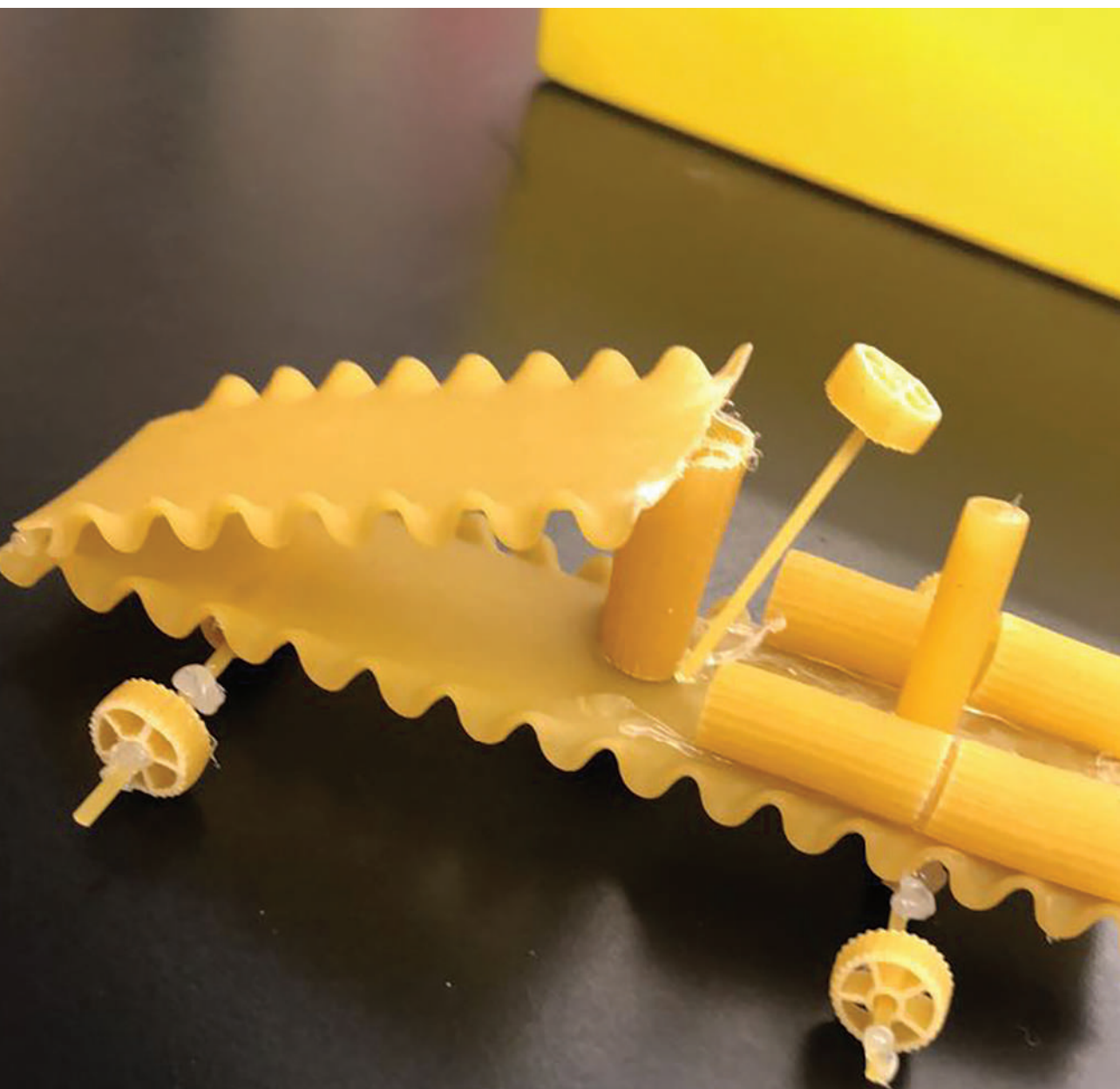

Now Skylar is a college student at the same university as Christian Yamada. Learning engineering there includes solving problems that really help people. Here, Skylar works with a robotic arm. She uses the tablet to teach the arm what she wants it to do. What would you teach a robotic arm to do? How would it help people?



Teamwork is important for most engineering jobs. One summer, Skylar worked on a team to invent a machine. The goal was to use it to speed up the construction of military vehicles. In the first three weeks, the students planned their solution. It took about four more weeks to get the materials they needed. In the last five weeks, they put the parts together, tested their machine, and made improvements.

“My team worked very well together. We had [like] a smaller team that worked on electrical, and then we had a smaller team that worked on the motion system.” Skylar worked with another student on a part of the machine that uses compressed air. Compressed air is pressed into a tight container. When it is released, it has force that can make machine parts move.



She is learning about living systems and how they affect people's health. She is learning about the human body and how its parts work together. She is learning about the health problems people can have.

What will Skylar do when she graduates from college? She still plans to become a biomedical engineer. As a biomedical engineer, Skylar will try to find solutions to people's health problems.

She might design new devices to place inside the eye that will help blind people see. These devices work to let people sense light better and see some shapes.

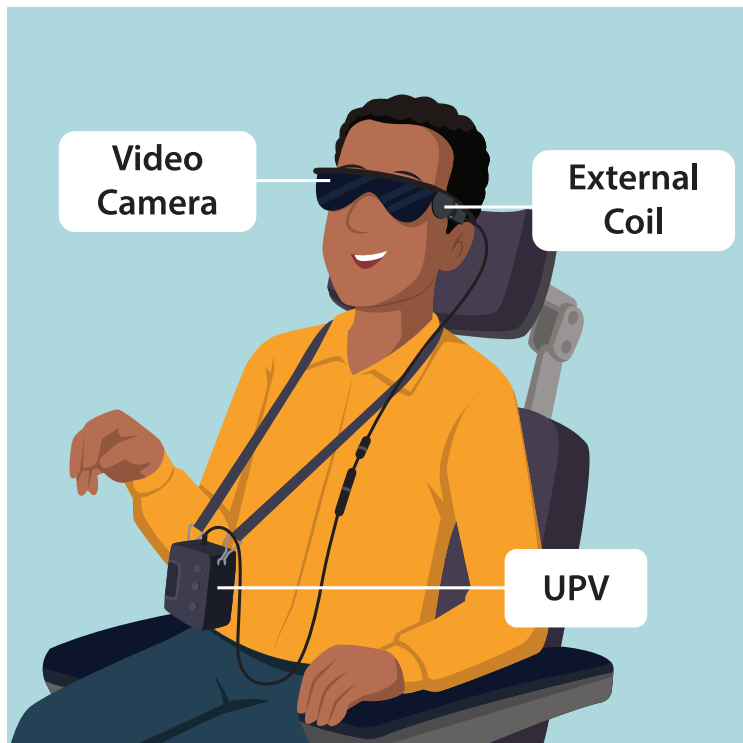

**Neuroengineering**, a branch of biomedical engineering, uses engineering to help correct damage and weaknesses in the brain and nervous system. A person who has brain damage may be impacted because their brain no longer communicates the same way with their nervous system and body.

She might invent devices such as this one. This is a microchip that helps the body and brain communicate with each other again. It can be placed inside the human body to help people move.

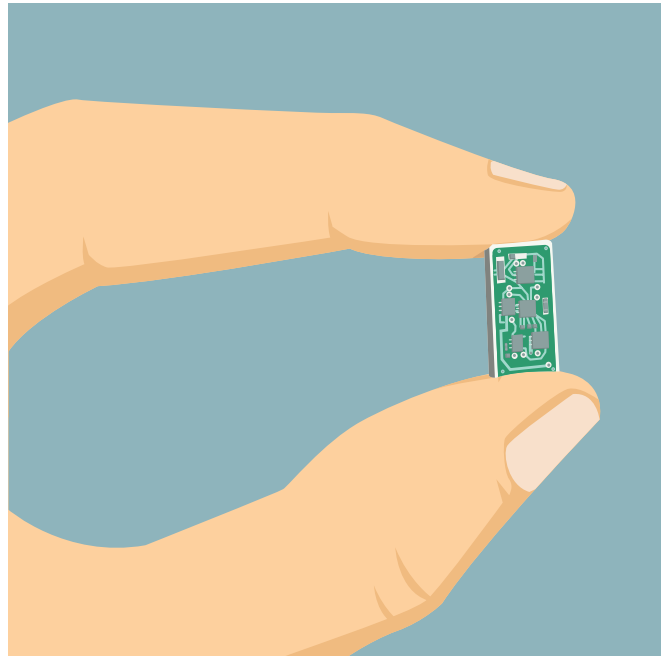

She hopes that devices placed in a person's brain can help people who cannot walk or talk.

# Inspired by . . .

To be **inspired** by someone means they made us want to try something. Skylar Neilsen's mom inspired her to become an engineer. Her dad said she should always follow her dreams. Skylar was also inspired to get into science by Rosalind Franklin.

## Rosalind Franklin, British Chemist

**Born** in 1920, in England

### Childhood Interests . . .

Young Rosalind did well in science and math and liked to be in charge of school projects. At age fifteen, she decided she wanted to be a scientist. But Rosalind's father did not think girls should go to college. Her mother and aunt helped him change his mind.

### Famous for . . .

Franklin is known for a photo she took that led to the discovery of the structure of DNA. DNA is the matter that codes for inherited traits in living things. Knowing the structure of DNA helped Watson and Crick understand how DNA worked.

### Words of Wisdom . . .

"... by doing our best we shall come nearer to success ..."

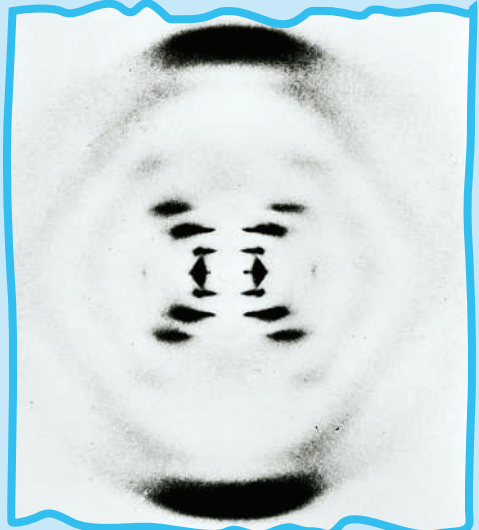

Rosalind Franklin's famous photograph from 1953 showed the structure of DNA.

Rosalind Franklin was inspired by the science discoveries of Linus Pauling.

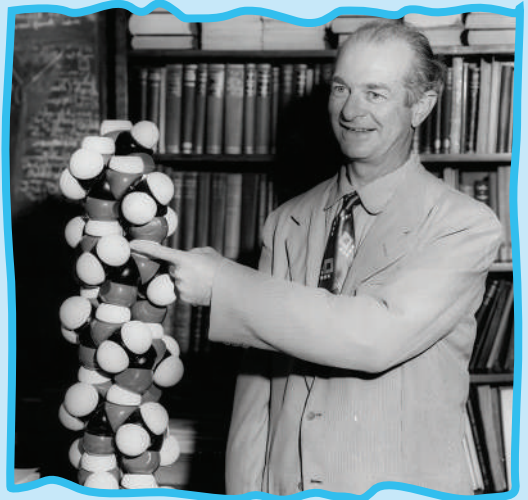

## Linus Pauling-American Chemist and Educator

**Born** in 1901, in Oregon

### Childhood Interests . . .

Young Linus had a friend with a toy chemistry set. Linus's parents did not have enough money to buy a set for their son, so Linus made his own with equipment and materials he found.

### Famous for . . .

As a scientist, Pauling explained how particles of matter called *atoms* attach to one another to make all different kinds of matter. In the photo, you can see a model Pauling built to help explain one of his discoveries.

### Words of Wisdom . . .

"Science is the search for truth . . ."



Who inspires you to find out more about the way things happen?  
Who has helped you figure out how something works?





Core Knowledge®

**CKSci™**

Core Knowledge **SCIENCE™**

**Editorial Director**

Daniel H. Franck

## Subject Matter Expert

Martin Rosenberg, PhD

Teacher of Physics and Computer Science

SAR High School

Riverdale, New York

## Illustration and Photo Credits

Adrian Sherratt / Alamy Stock Photo: 41

Allen Brown / Alamy Stock Photo: i, iii, 14

Christian Yamada: 12, 13

Colin Underhill / Alamy Stock Photo: 15c

Connect Images / Alamy Stock Photo: 17

Directphoto Collection / Alamy Stock Photo: 15a

dpa picture alliance archive / Alamy Stock Photo: 22b

Fahroni / Alamy Stock Photo: 20b

gualtiero boffi / Alamy Stock Photo: 35

History and Art Collection / Alamy Stock Photo: Cover D, 21

inga spence / Alamy Stock Photo: 20a

Leon Werdinger / Alamy Stock Photo: 19

Lev Dolgachov / Alamy Stock Photo: 37

Milan Ilic / Alamy Stock Photo: 18b

Panther Media GmbH / Alamy Stock Photo: 45b

Photo 12 / Alamy Stock Photo: 45a

Piccillo Photography / Alamy Stock Photo: 15b

Pictorial Press Ltd / Alamy Stock Photo: Cover A, 44a

Robert Clay / Alamy Stock Photo: 22a

RTimages / Alamy Stock Photo: 16

Science History Images / Alamy Stock Photo: 23, 44b

Science Photo Library / Alamy Stock Photo: 20d

Skylar Neilsen: Cover C, 34, 36, 39, 40

Stuart Boulton / Alamy Stock Photo: 20c



# CKSci™ Core Knowledge SCIENCE™

A comprehensive program in science, integrating topics from Earth and Space, Life, and Physical Sciences with concepts specified in the **Core Knowledge Sequence** (content and skill guidelines for Grades K–8).

## CK SCIENCE IN ACTION™

units in this series include:

**Grade K: Kyle and Jamie**

**Grade 1: Daniela and Thaís**

**Grade 2: Laura and Sandra**

**Grade 3: Christian and Skylar**

**Grade 4: Pearl, Dan, and Ken**

**Grade 5: Rowan and Gianna**

[www.coreknowledge.org](http://www.coreknowledge.org)

## Core Knowledge Curriculum Series™