

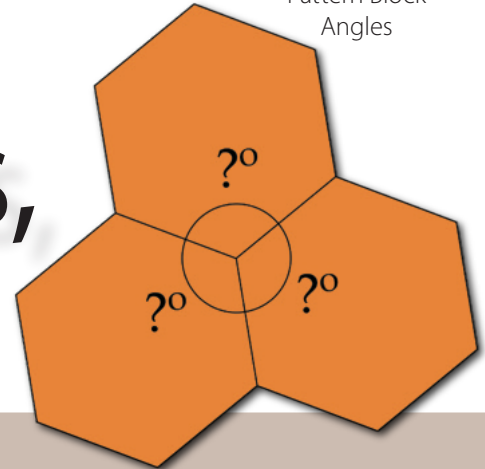

Angles, Triangles, and Prisms

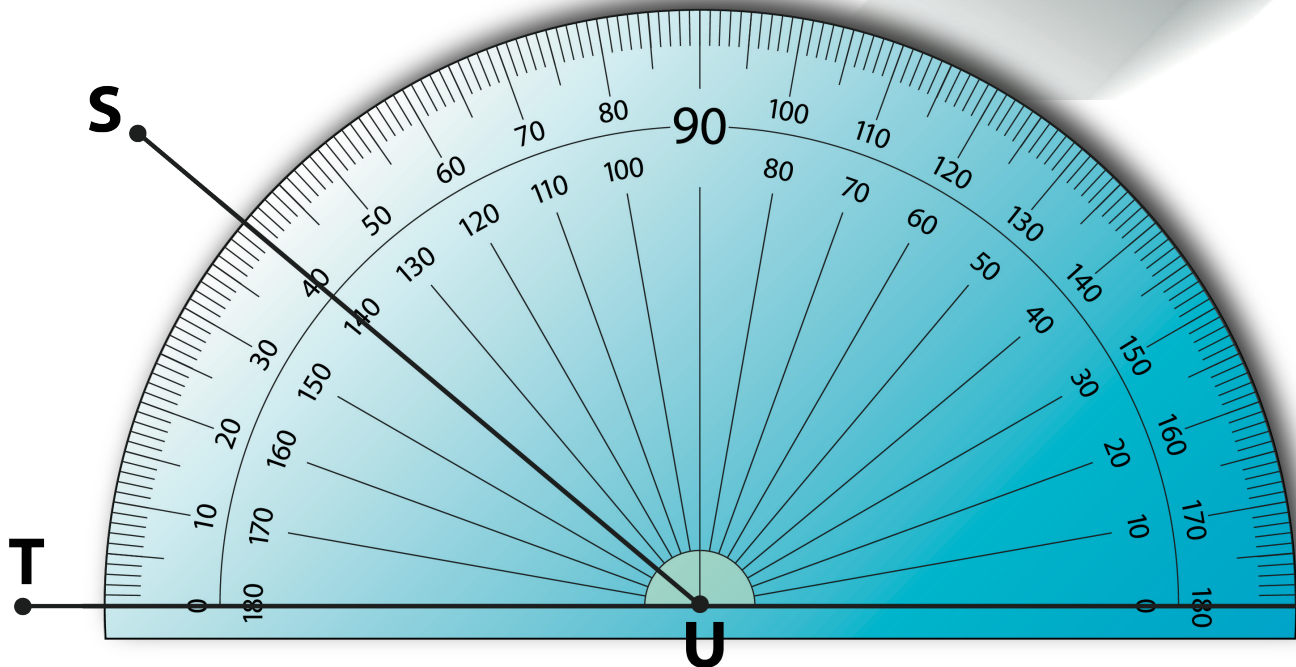

Teacher Guide

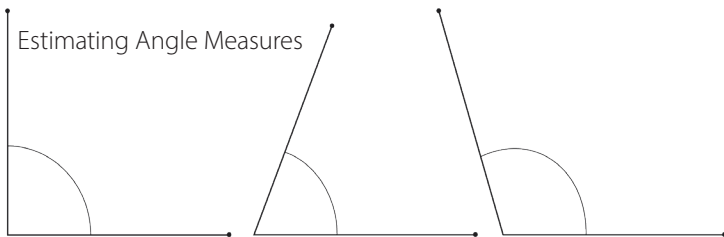
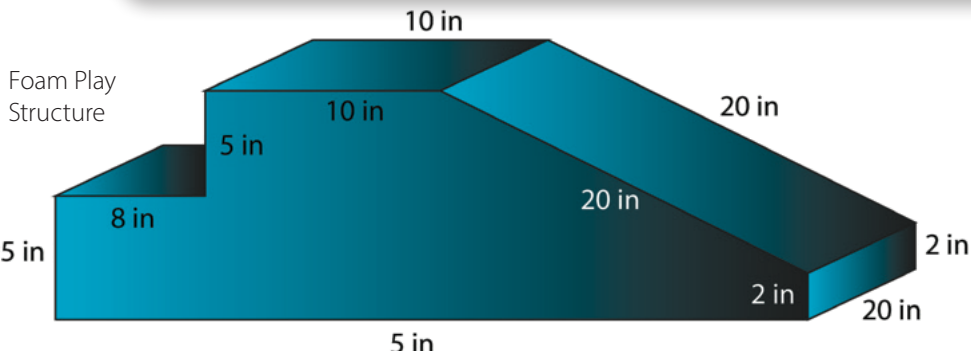

Measuring angle

Creative Commons Licensing

This work is licensed under a Creative Commons Attribution-NonCommercial-ShareAlike 4.0 International License.



You are free:

- to Share**—to copy, distribute, and transmit the work
- to Remix**—to adapt the work

Under the following conditions:

Attribution—You must attribute the work in the following manner:

CKMath 6–8 was originally developed by Open Up Resources and authored by Illustrative Mathematics, <https://www.illustrativemathematics.org>, and is copyrighted as 2017–2019 by Open Up Resources. It is licensed under the Creative Commons Attribution 4.0 International License (CC BY 4.0). The Open Up Resources 6–8 Math Curriculum is available at: <https://www.openupresources.org/math-curriculum/>.

Adaptations and updates to the IM 6–8 Math English language learner supports and the additional English assessments marked as "B" are copyright 2019 by Open Up Resources and licensed under the Creative Commons Attribution 4.0 International License (CC BY 4.0).

Adaptations and updates to the IM K–8 Math Spanish translation of assessments marked as "B" are copyright 2019 by Illustrative Mathematics. These adaptations and updates are licensed under the Creative Commons Attribution 4.0 International License (CC BY 4.0).

This particular work is based on additional work of the Core Knowledge® Foundation (www.coreknowledge.org) made available through licensing under a Creative Commons Attribution-Non Commercial-Share Alike 4.0 International License. This does not in any way imply that the Core Knowledge Foundation endorses this work.

Noncommercial—You may not use this work for commercial purposes.

Share Alike—If you alter, transform, or build upon this work, you may distribute the resulting work only under the same or similar license to this one.

With the understanding that:

For any reuse or distribution, you must make clear to others the license terms of this work. The best way to do this is with a link to this web page:

<https://creativecommons.org/licenses/by-nc-sa/4.0/>

Copyright © 2023 Core Knowledge Foundation
www.coreknowledge.org

All Rights Reserved.

Core Knowledge®, Core Knowledge Curriculum Series™, Core Knowledge Math™ and CKMath™ are trademarks of the Core Knowledge Foundation.

Trademarks and trade names are shown in this book strictly for illustrative and educational purposes and are the property of their respective owners. References herein should not be regarded as affecting the validity of said trademarks and trade names.

Angles, Triangles, and Prisms

Table of Contents

| | |
|---|-----|
| Introduction: Unit Narrative | 1 |
| Student Learning Targets | 3 |
| Terminology | 6 |
| Required Materials | 7 |
| Lessons Plans and Student Task Statements: | |
| Section 1: Lessons 1–5 Angle Relationships | 9 |
| Section 2: Lessons 6–10 Drawing Polygons with Given Conditions | 89 |
| Section 3: Lessons 11–16 Solid Geometry | 168 |
| Section 4: Lesson 17 Let’s Put It to Work | 256 |
| Teacher Resources | 269 |
| Family Support Materials | |
| Unit Assessments | |
| Assessment Answer Keys | |
| Cool Downs (Lesson-Level Assessments) | |
| Instructional Masters | |

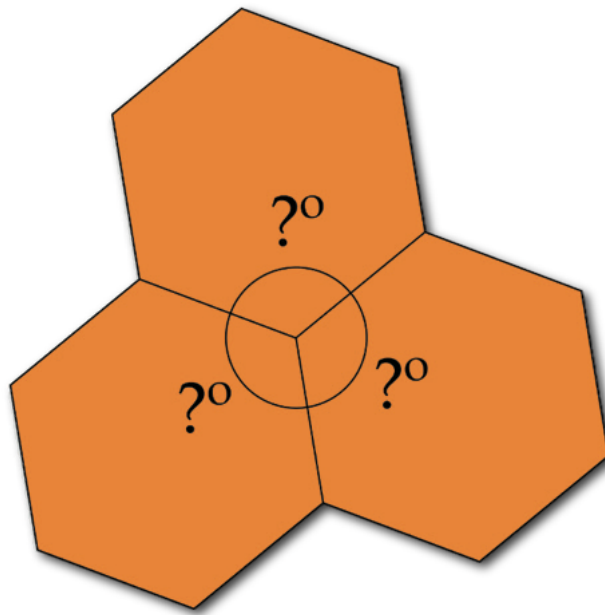

Angles, Triangles, and Prisms Teacher Guide

Core Knowledge Mathematics™

Angles, Triangles, and Prisms

Unit Narrative

In this unit, students investigate whether sets of angle and side length measurements determine unique triangles or multiple triangles, or fail to determine triangles. Students also study and apply angle relationships, learning to understand and use the terms “complementary,” “supplementary,” “vertical angles,” and “unique” (MP6). The work gives them practice working with rational numbers and equations for angle relationships. Students analyze and describe cross-sections of prisms, pyramids, and polyhedra. They understand and use the formula for the volume of a right rectangular prism, and solve problems involving area, surface area, and volume (MP1, MP4). Students should have access to their geometry toolkits so that they have an opportunity to select and use appropriate tools strategically (MP5).

Note: It is not expected that students memorize which conditions result in a unique triangle, are impossible to create a triangle, or multiple possible triangles. Understanding that, for example, SSS information results in zero or exactly one triangle will be explored in high school geometry. At this level, students should attempt to draw triangles with the given information and notice that there is only one way to do it (or that it is impossible to do).

Progression of Disciplinary Language

In this unit, teachers can anticipate students using language for mathematical purposes such as critiquing, explaining, interpreting, and justifying. Throughout the unit, students will benefit from routines designed to grow robust disciplinary language, both for their own sense-making and for building shared understanding with peers. Teachers can formatively assess how students are using language in these ways, particularly when students are using language to:

Critique

- reasoning about measuring angles (Lesson 1)
- reasoning about decomposition of prisms (Lesson 13)
- reasoning about surface area of prisms (Lesson 14)

Explain

- how to measure angles (Lesson 2)
- how to find unknown angle measurements (Lessons 4 and 5)
- how to find the volume of prisms (Lessons 12 and 13)
- how to find the surface area of prisms (Lesson 14)

Interpret

- situations involving intersecting lines in order to form a conjecture (Lesson 3)
- which information is relevant to answer questions (Lesson 4)

- equations representing angle measurements (Lesson 5)
- situations involving volume and surface area (Lesson 15 and 16)

Justify

- whether or not shapes are identical copies (Lesson 6)
- whether or not measurements determine identical copies (Lesson 9)
- whether or not measurements determine unique triangles (Lesson 10)

In addition, students are expected to use language to compare angle measurements, compare triangles in a set, compare cross sections of figures, describe characteristics of pattern blocks, describe positioning and movement of side lengths and angles, and describe cross sections of prisms and pyramids. Students also have opportunities to generalize about patterns of angle measurements, about categories for unique triangles, and about categories for cross sections.

The table shows lessons where new terminology is first introduced, including when students are expected to understand the word or phrase receptively and when students are expected to produce the word or phrase in their own speaking or writing. Terms from the glossary appear bolded. Teachers should continue to support students' use of a new term in the lessons that follow where it was first introduced.

Learning Targets

Angles, Triangles, and Prisms

Lesson 1: Relationships of Angles

- I can find unknown angle measures by reasoning about adjacent angles with known measures.
- I can recognize when an angle measures 90° , 180° , or 360° .

Lesson 2: Adjacent Angles

- I can find unknown angle measures by reasoning about complementary or supplementary angles.
- I can recognize when adjacent angles are complementary or supplementary.

Lesson 3: Nonadjacent Angles

- I can determine if angles that are not adjacent are complementary or supplementary.
- I can explain what vertical angles are in my own words.

Lesson 4: Solving for Unknown Angles

- I can reason through multiple steps to find unknown angle measures.
- I can recognize when an equation represents a relationship between angle measures.

Lesson 5: Using Equations to Solve for Unknown Angles

- I can write an equation to represent a relationship between angle measures and solve the equation to find unknown angle measures.

Lesson 6: Building Polygons (Part 1)

- I can show that the 3 side lengths that form a triangle cannot be rearranged to form a different triangle.
- I can show that the 4 side lengths that form a quadrilateral can be rearranged to form different quadrilaterals.

Lesson 7: Building Polygons (Part 2)

- I can reason about a figure with an unknown angle.
- I can show whether or not 3 side lengths will make a triangle.

Lesson 8: Triangles with 3 Common Measures

- I understand that changing which sides and angles are next to each other can make different triangles.

Lesson 9: Drawing Triangles (Part 1)

- Given two angle measures and one side length, I can draw different triangles with these measurements or show that these measurements determine one unique triangle or no triangle.

Lesson 10: Drawing Triangles (Part 2)

- Given two side lengths and one angle measure, I can draw different triangles with these measurements or show that these measurements determine one unique triangle or no triangle.

Lesson 11: Slicing Solids

- I can explain that when a three dimensional figure is sliced it creates a face that is two dimensional.
- I can picture different cross sections of prisms and pyramids.

Lesson 12: Volume of Right Prisms

- I can explain why the volume of a prism can be found by multiplying the area of the base and the height of the prism.

Lesson 13: Decomposing Bases for Area

- I can calculate the the volume of a prism with a complicated base by decomposing the base into quadrilaterals or triangles.

Lesson 14: Surface Area of Right Prisms

- I can find and use shortcuts when calculating the surface area of a prism.
- I can picture the net of a prism to help me calculate its surface area.

Lesson 15: Distinguishing Volume and Surface Area

- I can decide whether I need to find the surface area or volume when solving a problem about a real-world situation.

Lesson 16: Applying Volume and Surface Area

- I can solve problems involving the volume and surface area of children's play structures.

Lesson 17: Building Prisms

- I can build a triangular prism from scratch.

| lesson | new terminology | |
|--------|--|---|
| | receptive | productive |
| 7.7.1 | straight angle adjacent angles degree | right angle |
| 7.7.2 | supplementary complementary angle measure protractor | measurement error degrees |
| 7.7.3 | vertical angles intersect vertex (of an angle) | |
| 7.7.4 | | supplementary vertical angles |
| 7.7.5 | perpendicular | complementary |
| 7.7.6 | identical copy condition | angle measure side length quadrilateral |
| 7.7.7 | compass different triangle | intersect identical copy segment |
| 7.7.8 | | condition different triangle |
| 7.7.9 | unique triangle parallel | |
| 7.7.10 | | protractor compass |
| 7.7.11 | cross section base (of a prism or pyramid) vertex (of a pyramid) face | prism pyramid perpendicular parallel |

| lesson | new terminology | |
|--------|-----------------|---|
| | receptive | productive |
| 7.7.12 | | volume cross section base (of a prism or pyramid) |
| 7.7.14 | | face perimeter |
| 7.7.15 | | surface area |

Required Materials

Blank paper

Compasses

Copies of Instructional master

Fruits or vegetables

Geometry toolkits

For grade 6: tracing paper, graph paper, colored pencils, scissors, and an index card to use as a straightedge or to mark right angles.

For grades 7 and 8: everything in grade 6, plus a ruler and protractor. Clear protractors with no holes and with radial lines printed on them are recommended.

Notes: (1) "Tracing paper" is easiest to use when it's a smaller size. Commercially-available "patty paper" is 5 inches by 5 inches and ideal for this. If using larger sheets of tracing paper, consider cutting them down for student use. (2) When compasses are required in grades 6-8 they are listed as a separate Required Material.

Knife

Materials assembled from the Instructional master

Metal paper fasteners

brass brads

Paint

Pattern blocks

Pre-assembled polyhedra

Pre-printed cards, cut from copies of the Instructional master

Pre-printed slips, cut from copies of the Instructional master

Protractors

Clear protractors with no holes and with radial lines printed on them are recommended.

Rulers marked with centimeters

Scissors

Snap cubes

Straightedges

A rigid edge that can be used for drawing line segments. Sometimes a ruler is okay to use as a straightedge, but sometimes it is preferable to use an unruled straightedge, like a blank index card.

| lesson | new terminology | |
|--------|-----------------|---|
| | receptive | productive |
| 7.7.12 | | volume cross section base (of a prism or pyramid) |
| 7.7.14 | | face perimeter |
| 7.7.15 | | surface area |

Required Materials

Blank paper

Compasses

Copies of Instructional master

Fruits or vegetables

Geometry toolkits

For grade 6: tracing paper, graph paper, colored pencils, scissors, and an index card to use as a straightedge or to mark right angles.

For grades 7 and 8: everything in grade 6, plus a ruler and protractor. Clear protractors with no holes and with radial lines printed on them are recommended.

Notes: (1) "Tracing paper" is easiest to use when it's a smaller size. Commercially-available "patty paper" is 5 inches by 5 inches and ideal for this. If using larger sheets of tracing paper, consider cutting them down for student use. (2) When compasses are required in grades 6-8 they are listed as a separate Required Material.

Knife

Materials assembled from the Instructional master

Metal paper fasteners

brass brads

Paint

Pattern blocks

Pre-assembled polyhedra

Pre-printed cards, cut from copies of the Instructional master

Pre-printed slips, cut from copies of the Instructional master

Protractors

Clear protractors with no holes and with radial lines printed on them are recommended.

Rulers marked with centimeters

Scissors

Snap cubes

Straightedges

A rigid edge that can be used for drawing line segments. Sometimes a ruler is okay to use as a straightedge, but sometimes it is preferable to use an unruled straightedge, like a blank index card.

Section: Angle Relationships

Lesson 1: Relationships of Angles

Goals

- Comprehend and use the word “degrees” (in spoken and written language) and the symbol $^\circ$ (in written language) to refer to the amount of turn between two different directions.
- Recognize 180° and 360° angles, and identify when adjacent angles add up to these amounts.
- Use reasoning about adjacent angles to determine the angle measures of pattern blocks, and justify (orally) the reasoning.

Learning Targets

- I can find unknown angle measures by reasoning about adjacent angles with known measures.
- I can recognize when an angle measures 90° , 180° , or 360° .

Lesson Narrative

Students were introduced to angles in grade 4, when they drew angles, measured angles, identified angles as acute, right, or obtuse, and worked with adding and subtracting angles. Earlier in grade 7, students also touched on angles briefly in their work with scale drawings. Now they begin a more detailed study of angles.

In this lesson, students gain hands-on experience composing, decomposing, and measuring angles. They refresh their memory about the relationship between **right angles**, **straight angles** (180°), and “all the way around” angles (360°), and they fit pattern blocks around a point to find out the angles at their vertices. They use simple equations they learned about in the previous unit to solve for angles.

Alignments

Building On

- 4.MD.C.6: Measure angles in whole-number degrees using a protractor. Sketch angles of specified measure.
- 4.MD.C.7: Recognize angle measure as additive. When an angle is decomposed into non-overlapping parts, the angle measure of the whole is the sum of the angle measures of the parts. Solve addition and subtraction problems to find unknown angles on a diagram in real world and mathematical problems, e.g., by using an equation with a symbol for the unknown angle measure.

Addressing

- 7.G.A: Draw, construct, and describe geometrical figures and describe the relationships between them.
- 7.G.B: Solve real-life and mathematical problems involving angle measure, area, surface area, and volume.

Building Towards

- 7.G.B: Solve real-life and mathematical problems involving angle measure, area, surface area, and volume.
- 7.G.B.5: Use facts about supplementary, complementary, vertical, and adjacent angles in a multi-step problem to write and solve simple equations for an unknown angle in a figure.

Instructional Routines

- Anticipate, Monitor, Select, Sequence, Connect
- MLR1: Stronger and Clearer Each Time
- MLR2: Collect and Display
- MLR5: Co-Craft Questions
- Think Pair Share

Required Materials

Blank paper

Pattern blocks

Protractors

Clear protractors with no holes and with radial lines printed on them are recommended.

Scissors

Straightedges

A rigid edge that can be used for drawing line segments. Sometimes a ruler is okay to use as a straightedge, but sometimes it is preferable to use an unruled straightedge, like a blank index card.

Required Preparation

Prepare one set of pattern blocks for each group of 3–4 students, include blocks consisting of at least 3 yellow hexagons and 6 of each of the other shapes.

Student Learning Goals

Let's examine some special angles.

1.1 Visualizing Angles

Warm Up: 5 minutes (there is a digital version of this activity)

The purpose of this warm-up is to bring back to mind what students have learned previously about angle measures, as well as to discuss what aspects of each figure is important and which aspects can be ignored. Students may benefit from the use of an Angle Window: a scrap of paper with a

penny-sized hole torn in the center of it. Students position the window so that the vertex of the angle and the beginning of the two rays are visible through the hole. This helps block out distractions, such as the lengths on the sides of the angle or other objects in the diagram.

The first question addresses the misconception that the size of an angle is related to lengths of line segments. The second question shows students they must be specific about how they refer to angles that share a vertex and introduces students to thinking about overlapping angles. Monitor for students who use different names for the same angle.

Addressing

- 7.G.A

Building Towards

- 7.G.B.5

Launch

Give students 1 minute of quiet work time, followed by a whole-class discussion.

If using the digital activity, make sure students realize they can drag the angles to compare size.

Anticipated Misconceptions

In the first question, students may say that the angle measuring b degrees is larger than the angle measuring a degrees because the line segments are longer. Show them how to use an Angle Window positioned over the vertex to focus on the amount of turn between the two rays and ignore the length of the line segments.

In the second question, students may say that there is no obtuse angle, because they are only looking at $\angle DAC$ and $\angle CAB$ and not noticing the overlapping angle $\angle DAB$. Reassure them that there is an obtuse angle in the figure, and ask them if $\angle DAC$ and $\angle CAB$ are the only angles present in the figure. Another possibility is to tell them that the obtuse angle has a measure of 110 degrees to help them find it.

Student Task Statement

1. Which angle is bigger?

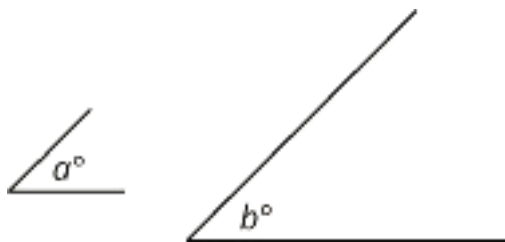

2. Identify an obtuse angle in the diagram.

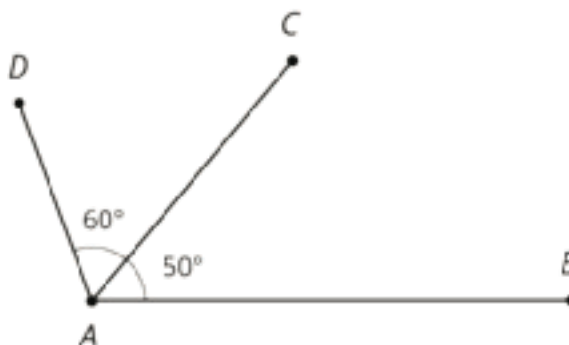

Student Response

1. Neither. Both angles have the same measure.
2. Angle DAB (or angle BAD) is obtuse. It measures 110° because $60 + 50 = 110$.

Activity Synthesis

The goal of this discussion is to ensure that students understand that angles measure the amount of turn between two different directions. Poll the class on their responses for the first question. Make sure students reach an agreement that both angles in the first question are the same size. If there is a lot of disagreement, it may be helpful to demonstrate the use of an Angle Window for the whole class. If using the digital version of the materials, either angle a or b can be dragged on top of the other to demonstrate that they have the same measure.

Display the figure in the second question, and ask previously identified students to share their responses. Make sure students understand that saying angle A is not specific enough when referring to this diagram, because there is more than one angle with its vertex at point A . Consider asking questions like these:

- “What is the measure of angle A ?”
- “Which angle is angle A ?”
- “Why is it not good enough to say angle A when referring to this diagram?”

Explain to the students that by using three points to refer to an angle, we can be sure that others will understand which angle we are talking about. Have students practice this way of referring to angles by asking questions such as:

- “Which angle is bigger, angle DAC or angle CAB ?” (Angle DAC is bigger because its measure is 60 degrees. It doesn’t matter that segment BA is longer than segment DA .)
- “Which angle is bigger, angle CAB or angle BAC ?” (They are both the same size, because they are two names for the same angle.)

Also explain to students that in a diagram an arc is often placed between the two sides of the angle being referenced.

Tell students that angles DAC and CAB are known as **adjacent angles** because they are next to each other, sharing segment AC as one of their sides and A as their vertex.

1.2 Pattern Block Angles

15 minutes (there is a digital version of this activity)

The purpose of this activity is to use the fact that the sum of the angles all the way around a point is 360° to reason about the measure of other angles. Students are reminded that angle measures are additive (4.MD.C.7) before undertaking work with complementary and supplementary angles in future lessons.

Formally, a right angle is 90° because we defined 360° to be all the way around and $\frac{1}{4} \cdot 360 = 90$. Students may have forgotten about 360° , but they are likely to remember 90° from their work with angles in grade 4. We can use right angles as a tool to rediscover that all the way around must be 360° , because $4 \cdot 90 = 360$.

In this activity, students use pattern blocks to explore configurations that make 360° and to solve for angles of the individual blocks. For this activity, there are multiple configurations of blocks that will accomplish the task.

As students work, monitor for those who:

- use similar reasoning in the launch to figure out the measure of the various angles they traced from the pattern blocks.
- find relationships between different angle measures and different pattern blocks (for example: one hexagon angle is also 2 green triangles, which means one green triangle angle is 60° because $\frac{1}{2} \cdot 120 = 60$).

Building On

- 4.MD.C.7

Addressing

- 7.G.B

Building Towards

- 7.G.B.5

Instructional Routines

- Anticipate, Monitor, Select, Sequence, Connect
- MLR2: Collect and Display

Launch

Arrange students in groups of 3–4. Display the figures in this image one at a time, or use actual pattern blocks to recreate these figures for all to see.

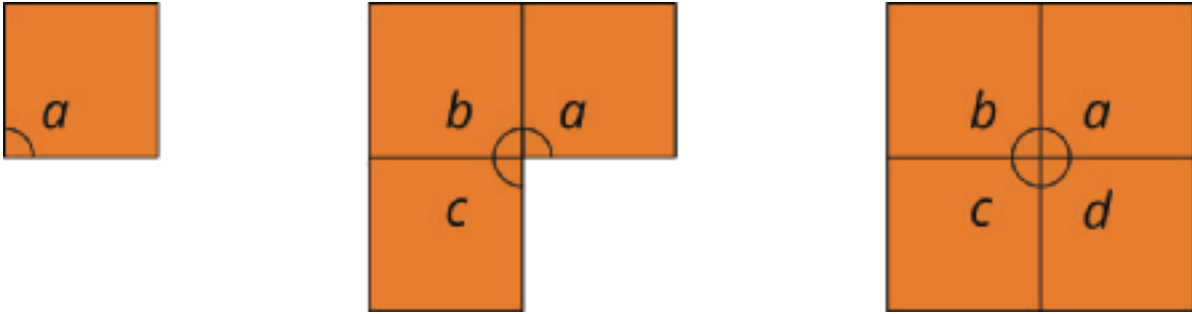

Ask these questions after each figure is displayed:

- “What is the measure of $\angle a$? How do you know?” (90° , because it is a right angle.)
- “What is the measure of $a + b + c$?” (270° , because $90 + 90 + 90 = 270$.)
- “What is the measure of $a + b + c + d$?” (360° , because $4 \cdot 90 = 360$.)

Reinforce that 360° is once completely around a point by having students stand up, hold their arm out in front of them, and turn 360° around. Students who are familiar with activities like skateboarding or figure skating will already have a notion of 360° as a full rotation and 180° as half of a rotation.

Distribute pattern blocks. Or, if using the digital version of materials, demonstrate the use of the applet. Ensure students know that after they drag a block from the left to the right side of the window, they can click to rotate the block.

Access for Students with Disabilities

Representation: Develop Language and Symbols. Display or provide charts with the figures, symbols and meanings of the angle measures at the vertices for all the different pattern blocks.

Supports accessibility for: Conceptual processing; Memory

Anticipated Misconceptions

When working on calculating the angle measure, students might need to be reminded that a complete turn is 360° .

If students place angles that are not congruent next to each other, it could produce valid reasoning, but they may draw erroneous conclusions. For example, using four copies of the blue rhombus, you can place 2 obtuse angles and 2 acute angles around the same vertex with no gaps or overlaps.

However, this does not mean that they are each $\frac{1}{4}$ of 360° . Encourage students to reason about whether their conclusions make sense and to verify their conclusions in more than one way.

Student Task Statement

1. Trace one copy of every different pattern block. Each block contains either 1 or 2 angles with different degree measures. Which blocks have only 1 unique angle? Which have 2?
2. If you trace three copies of the hexagon so that one vertex from each hexagon touches the same point, as shown, they fit together without any gaps or overlaps. Use this to figure out the degree measure of the angle inside the hexagon pattern block.

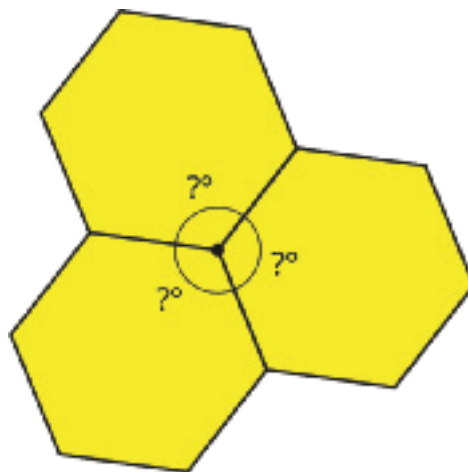

3. Figure out the degree measure of all of the other angles inside the pattern blocks that you traced in the first question. Be prepared to explain your reasoning.

Student Response

1. The hexagon, triangle, and square are all blocks with one unique angle measure. The trapezoid and both rhombuses are blocks with two different angle measures.
2. The degree measure of the angle inside the yellow hexagon is 120° , since it takes 3 to go around a point and $360 \div 3 = 120$.
3. For the green triangle, all 3 angles measure 60° , since it takes 6 to go around a point and $360 \div 6 = 60$.
For the tan rhombus, two of the angles measure 30° , since it takes 2 of them to equal the measure of a triangle and $60 \div 2 = 30$. The other two angles measure 150° , since 5 of the smaller angles can fit together to equal this angle measure and $30 \cdot 5 = 150$.
For the blue rhombus, two of the angles measure 60° , since they are the same angle as in the triangles, and the other two angles measure 120° since they are the same angle as in the hexagons.
For the red trapezoid, two of the angles measure 60° like the triangles, and the other two angles measure 120° like the hexagons.
For the orange square, all 4 angles measure 90° , since it takes 4 angles to go around a point and $360 \div 4 = 90$.

Are You Ready for More?

We saw that it is possible to fit three copies of a regular hexagon snugly around a point.

Each interior angle of a regular pentagon measures 108° . Is it possible to fit copies of a regular pentagon snugly around a point? If yes, how many copies does it take? If not, why not?

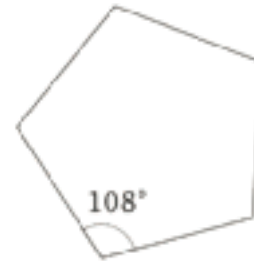

Student Response

No. Three copies gives 324° , because $3 \cdot 108 = 324$. This is not enough—there would be a gap left over—because 360° is needed to get all the way around. Four copies gives 432° , because $4 \cdot 108 = 432$. This is too much! The fourth copy would overlap the first, not fit snugly.

Activity Synthesis

The goal of this discussion is for students to be exposed to writing equations that represent the relationships between different angle measures. Select previously identified students to share how they figured out the different angle measures in each pattern block. Sequence the explanations from most common (reminiscent of the square and hexagon examples) to most creative.

Write an equation to represent how their angles add up to 360° . Listen carefully for how students describe their reasoning and make your equation match the vocabulary they use. For example, students might have reasoned about 6 green triangles by thinking $60 + 60 + 60 + 60 + 60 + 60 = 360$ or $6 \cdot 60 = 360$ or $360 \div 6 = 60$.

Once an angle from one block is known, it can be used to help figure out angles for other blocks. For example, students may say that they knew the angles on the yellow hexagon measured 120° because they could fit two of the green triangles onto one corner of the hexagon, and $60 + 60 = 120$ or $2 \cdot 60 = 120$. There are many different ways students could have reasoned about the angles on each block, and it is okay if they didn't think back to 360° for every angle.

Before moving on to the next activity, ensure that students know the measure of each interior angle of each shape in the set of pattern blocks. Display these measures for all to see throughout the remainder of the lesson.

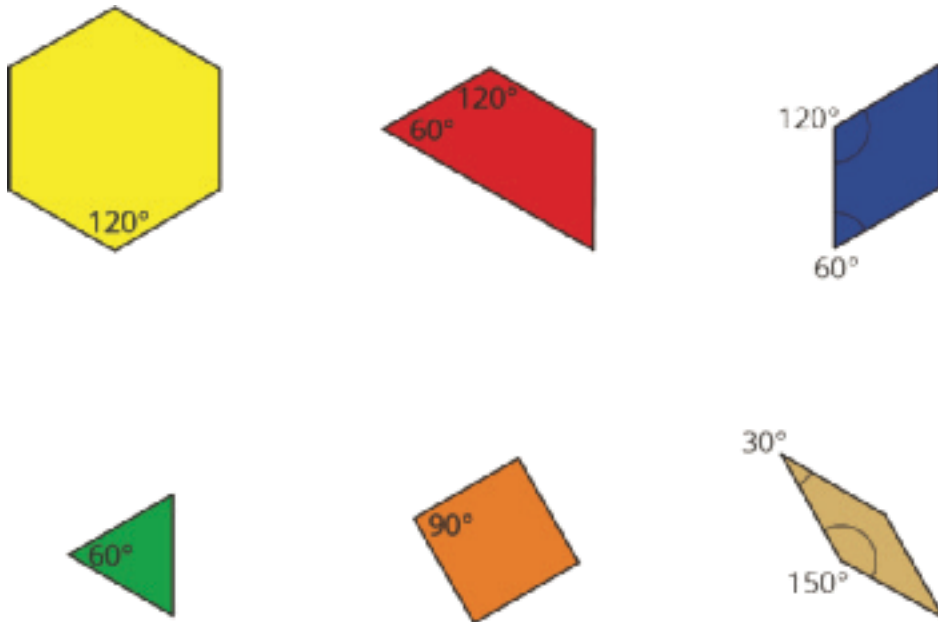

Access for English Language Learners

Speaking, Listening: MLR2 Collect and Display. Use this routine to capture existing student language related to finding the measure of a given angle. Circulate and listen to student talk during small-group and whole-class discussion. Record the words, phrases, drawings, and writing students use to explain the equations they wrote to represent the relationships between different angle measures. Display the collected language for all to see, and invite students to borrow from, or add more language to the display throughout the remainder of the lesson. It is expected that students will be using informal language when they explain their reasoning at this point in the unit. Over the course of the unit, invite students to suggest revisions, and updates to the display as they develop new mathematical ideas and new language to communicate them.

Design Principle(s): Support sense-making; Maximize meta-awareness

1.3 More Pattern Block Angles

10 minutes (there is a digital version of this activity)

In this activity, students figure out measures of given angles using the pattern block angles they discovered in the previous activity. Most importantly, students recognize that a straight angle can be considered an angle and not just a line. Students are asked to find different combinations of pattern blocks that form a straight angle, which helps students to see the connection between the algebraic action of summing angles and the geometric action of joining angles with the same vertex.

As students work on the task, monitor for students who use different combinations of blocks to form a straight angle.

Addressing

- 7.G.B

Instructional Routines

- MLR5: Co-Craft Questions

Launch

Students may need help focusing on the correct angles when there are multiple blocks involved. These students may benefit from using the Angle Window created in the warm-up for this lesson.

There are many ways to use the blocks to find the measures of the angles in the first question. Students are encouraged to find more than one way, and to check that their answers remain the same.

Give students 2–3 minutes of quiet work time followed by a partner and whole-class discussion.

Access for Students with Disabilities

Representation: Internalize Comprehension. Begin with a physical demonstration of using pattern blocks to determine the measure of an angle.

Supports accessibility for: Conceptual processing; Visual-spatial processing

Access for English Language Learners

Writing, Conversing: MLR5 Co-craft Questions. Use this routine to support language development through student conversations about mathematical questions. Without revealing the questions of the task, display only the image of the three angles for all to see. Invite students to work with a partner to write possible mathematical questions that could be asked about what they see. Listen for questions that connect the use of pattern blocks with measuring angles.

Design Principle(s): Cultivate conversation; Support sense-making

Anticipated Misconceptions

Some students may say that $b = 150$. Prompt them to notice that the arc marking which angle to measure is on the side that is greater than 180° .

If students are stuck on the angle that measures c degrees, consider using one of the patterns from the previous task that created a 360-degree angle with all the same pattern blocks and remove half of the pattern to show the 180-degree angle.

In the second problem, students might need encouragement to look for multiple combinations of pattern blocks to form a straight line.

Student Task Statement

1. Use pattern blocks to determine the measure of each of these angles.

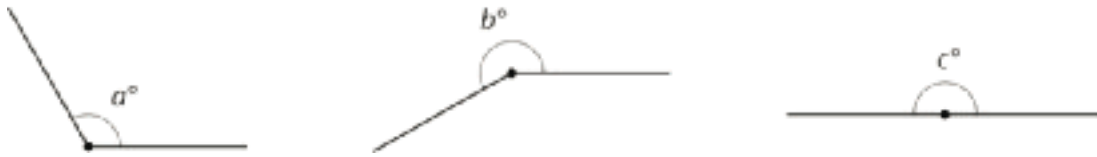

2. If an angle has a measure of 180° , then its sides form a straight line. An angle that forms a straight line is called a straight angle. Find as many different combinations of pattern blocks as you can that make a straight angle.

Student Response

1. Explanations vary.

- 120° because it is the same size as one vertex of the yellow hexagon or two green triangles put together.
- 210° because it is the same size as one yellow hexagon and one orange square put together.
- 180° because it is the same size as three green triangles put together.

2. Answers vary. Sample responses:

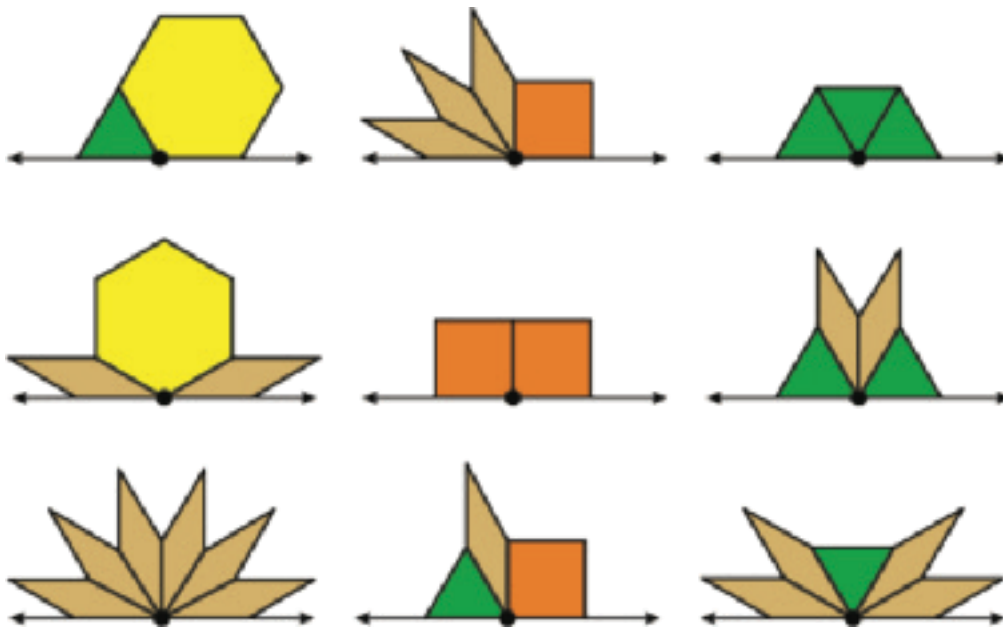

Activity Synthesis

The goal of this discussion is for students to be exposed to many different examples of angle measures summing to 180° .

First, instruct students to compare their answers to the first question with a partner and share their reasoning until they reach an agreement. To help students see c as a 180° -degree angle and not just

a straight line, consider using only the smaller angle on the tan rhombus blocks to measure all three figures: composing four tan rhombuses gives an angle measuring a degrees, seven rhombuses give an angle measuring b degrees, and six rhombuses give an angle measuring c degrees.

Next, select previously identified students to share their solutions to the second question. For each combination of blocks that is shared, invite other students in the class to write an equation displayed for all to see that reflects the reasoning.

1.4 Measuring Like This or That

Optional: 10 minutes

The purpose of this optional activity is to address the common error of reading a protractor from the wrong end. The problem gives students the opportunity to critique someone else's thinking and make an argument if they agree with either students' claim (MP3).

Building On

- 4.MD.C.6

Building Towards

- 7.G.B

Instructional Routines

- MLR1: Stronger and Clearer Each Time
- Think Pair Share

Launch

Arrange students in groups of 2. Give students 2–3 minutes of quiet think time followed by a partner and whole-class discussion.

Student Task Statement

Tyler and Priya were both measuring angle TUS .

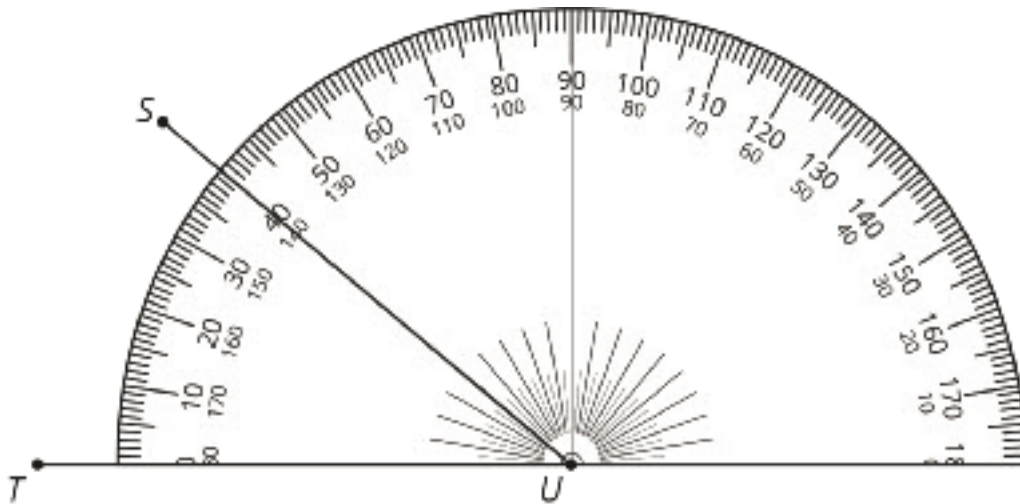

Priya thinks the angle measures 40 degrees. Tyler thinks the angle measures 140 degrees. Do you agree with either of them? Explain your reasoning.

Student Response

Answers vary. Sample response: I agree with Priya, since the angle clearly measures less than 90 degrees. I think Tyler measured from the wrong end of the protractor.

Activity Synthesis

Ask students to indicate whether they agree with Priya or Tyler. Invite students to explain their reasoning until the class comes to an agreement that the measurement of angle TUS is 40 degrees.

Ask students how Tyler could know that his answer of 140 degrees is unreasonable for the measure of angle TUS . Possible discussion points include:

- “Is angle TUS acute, right, or obtuse?” (acute)
- “Where is there an angle that measures 140 degrees in this figure?” (adjacent to angle TUS , from side US to the other side of the protractor)

Make sure that students understand that a protractor is often labeled with two sets of angle measures, and they need to consider which side of the protractor they are measuring from.

Access for English Language Learners

Speaking, Listening, Conversing: MLR1 Stronger and Clearer Each Time. Use this routine to give students a structured opportunity to revise and refine their explanation about whether or not they agree with Tyler or Priya. Give students time to meet with 2–3 partners, to share and get feedback on their responses. Provide students with prompts for feedback that will help their partners strengthen their ideas and clarify their language. For example, “What do you think each person did first?”, “Could Priya and Tyler both be correct?”, “Can you say that a different way?” Give students 1–2 minutes to revise their writing based on the feedback they received.

Design Principle(s): Cultivate conversation; Optimize output (for explanation)

Lesson Synthesis

- What are the three main types of angles in this lesson, and what are their measures? (right: 90° , straight: 180° , all the way around a point: 360°)
- What does it look like when angles are adjacent, and what can you say about angle measures? (The two angles are placed so that they share a vertex and one side. For adjacent angles, angle measures add. For example, a 60° angle adjacent to a 120° angle produces a 180° straight angle.)

1.5 Identical Isosceles Triangles

Cool Down: 5 minutes

Addressing

- 7.G.B

Building Towards

- 7.G.B.5

Launch

Consider displaying the image in color to help students understand the image.

Anticipated Misconceptions

Some students may continue to struggle to understand the image, even after seeing the color version. Help them mark all of the interior angles with either x or y . Alternatively, cut out the first shape and show how all the pieces can be rearranged to make the second shape.

Student Task Statement

Here are two different patterns made out of the same five identical isosceles triangles. Without using a protractor, determine the measures of $\angle x$ and $\angle y$. Explain or show your reasoning.

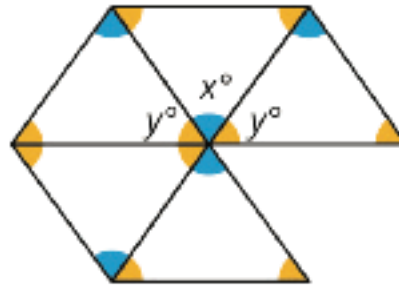
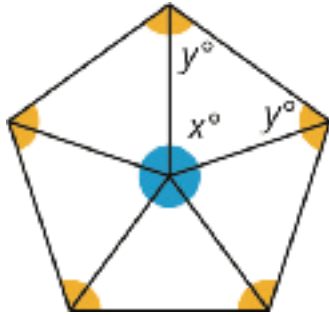

Student Response

$x = 72$ and $y = 54$. Since there are 5 copies of the angle that measures x around a single point in the first picture, we know that $5x = 360$, so $x = 72$. In the second picture, we know that two copies of y and one copy of x make a straight angle, so $2y + 72 = 180$. Since we already know x , we can figure out that $y = 54$.

Student Lesson Summary

When two lines intersect and form four equal angles, we call each one a **right angle**. A right angle measures 90° . You can think of a right angle as a quarter turn in one direction or the other.

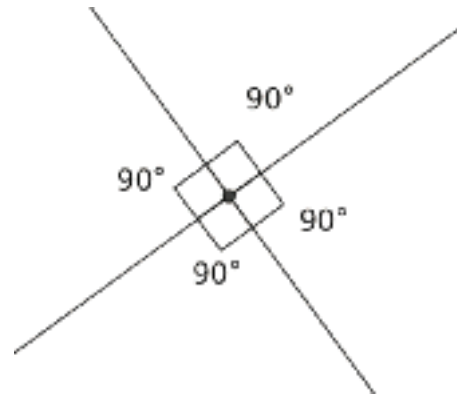

An angle in which the two sides form a straight line is called a **straight angle**. A straight angle measures 180° . A straight angle can be made by putting right angles together. You can think of a straight angle as a half turn, so that you are facing in the opposite direction after you are done.

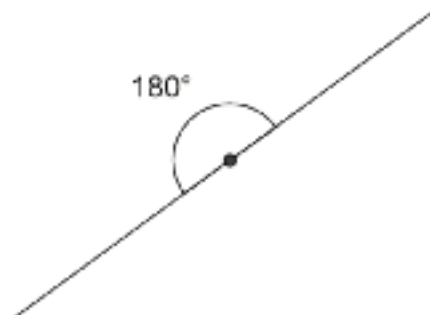

If you put two straight angles together, you get an angle that is 360° . You can think of this angle as turning all the way around so that you are facing the same direction as when you started the turn.

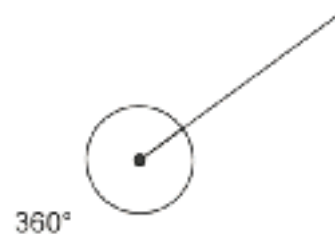

When two angles share a side and a vertex, and they don't overlap, we call them **adjacent angles**.

Glossary

- adjacent angles
- right angle
- straight angle

Lesson 1 Practice Problems

Problem 1

Statement

Here are questions about two types of angles.

- Draw a right angle. How do you know it's a right angle? What is its measure in degrees?
- Draw a straight angle. How do you know it's a straight angle? What is its measure in degrees?

Solution

- 90° . Responses vary. Sample responses: I used a protractor and measured; a square pattern block fits perfectly inside it; the corner of my notebook paper fits perfectly inside it.
- 180° . Responses vary. Sample response: I drew a straight line, and a straight angle is an angle formed by a straight line.

Problem 2

Statement

An equilateral triangle's angles each have a measure of 60 degrees.

- Can you put copies of an equilateral triangle together to form a straight angle? Explain or show your reasoning.
- Can you put copies of an equilateral triangle together to form a right angle? Explain or show your reasoning.

Solution

- Yes. 3 triangles are needed because $180 \div 3 = 60$.
- No. One 60° angle is not enough, and two is too much.

Problem 3

Statement

Here is a square and some regular octagons.

In this pattern, all of the angles inside the octagons have the same measure. The shape in the center is a square. Find the measure of one of the angles inside one of the octagons.

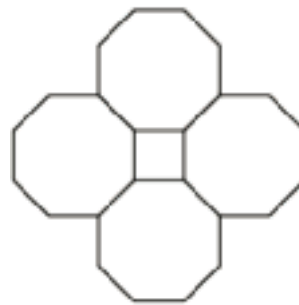

Solution

135°

Problem 4

Statement

The height of the water in a tank decreases by 3.5 cm each day. When the tank is full, the water is 10 m deep. The water tank needs to be refilled when the water height drops below 4 m.

- Write a question that could be answered by solving the equation $10 - 0.035d = 4$.
- Is 100 a solution of $10 - 0.035d > 4$? Write a question that solving this problem could answer.

Solution

Answers vary. Sample response:

- "How many days can pass before the water tank needs to be refilled?"
- Yes. "Is there still enough water in the tank after 100 days?"

(From Unit 6, Lesson 17.)

Problem 5

Statement

Use the distributive property to write an expression that is equivalent to each given expression.

- $-3(2x - 4)$
- $0.1(-90 + 50a)$
- $-7(-x - 9)$
- $\frac{4}{5}(10y + -x + -15)$

Solution

a. $-6x + 12$

b. $-9 + 5a$

c. $7x + 63$

d. $8y - \frac{4}{5}x - 12$

(From Unit 6, Lesson 18.)

Problem 6

Statement

Lin's puppy is gaining weight at a rate of 0.125 pounds per day. Describe the weight gain in days per pound.

Solution

8 days per pound

(From Unit 2, Lesson 3.)

Lesson 2: Adjacent Angles

Goals

- Comprehend the terms “complementary” and “supplementary” (in spoken and written language) as they describe pairs of angles.
- Explain (orally and in writing) how to find an unknown angle measure, given adjacent complementary or supplementary angles.
- Generalize (orally) that when a straight angle or a right angle is decomposed, the measures of the resulting angles add up to 180° or 90° , respectively.

Learning Targets

- I can find unknown angle measures by reasoning about complementary or supplementary angles.
- I can recognize when adjacent angles are complementary or supplementary.

Lesson Narrative

In this lesson, students are introduced to the terms **complementary**, for describing two angles whose measures add to 90° , and **supplementary**, for describing two angles whose measures add to 180° . They practice finding an unknown angle given the measure of another angle that is complementary or supplementary.

Many of the angles in this lesson share the same vertex as another angle, so students need to be careful when naming each angle (MP6) in addition to describing the relationship between pairs of angles.

Alignments

Building On

- 4.MD.C: Geometric measurement: understand concepts of angle and measure angles.

Addressing

- 7.G.B: Solve real-life and mathematical problems involving angle measure, area, surface area, and volume.
- 7.G.B.5: Use facts about supplementary, complementary, vertical, and adjacent angles in a multi-step problem to write and solve simple equations for an unknown angle in a figure.

Instructional Routines

- MLR3: Clarify, Critique, Correct
- MLR8: Discussion Supports

Required Preparation

Cut blank paper in half so that each student can have 2 half sheets of paper. It is very important that these cuts are completely straight and exactly perpendicular to the sides being cut for this activity to work.

Prepare to distribute scissors, straightedges, and protractors.

Student Learning Goals

Let's look at some special pairs of angles.

2.1 Estimating Angle Measures

Warm Up: 5 minutes

The purpose of this warm-up is for students to estimate degree measures (without a protractor) based on angles that are familiar. In the first two rows, an angle that is close to either a right angle or straight angle is given, and students could use this as a reference angle for the other angles in the row.

Asking students to share a wrong estimate first is a good strategy for launching the activity, because students are more confident in sharing wrong estimates, and it can help them start to consider what would be a more correct estimate.

As student discuss with their partner, monitor for students who use phrases such as:

- “a little more than 90 degrees”
- “almost a straight line”
- “a little less than 360 degrees”

Building On

- 4.MD.C

Addressing

- 7.G.B

Launch

Arrange students in groups of 2. Do not supply protractors or pattern blocks; let students know that in this activity they are *estimating* the degree measure of each angle.

Before students begin, ask students to think of an estimate that is *definitely wrong* for angle GHI . Invite a few students to share and explain why it is wrong. Then, ask the same students to come up with an actual estimate.

Give students 2 minutes of quiet work time followed by a partner and whole-class discussion.

Anticipated Misconceptions

Students will be tempted to figure out the exact angle measures, encourage students to use estimation to see how close they can get using benchmark angles that they have encountered (90° , 180° , 360° , etc).

Student Task Statement

Estimate the degree measure of each indicated angle.

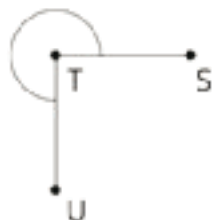
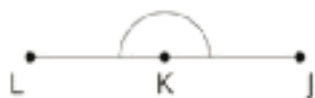
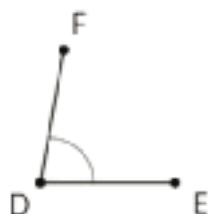
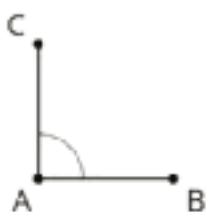

Student Response

- Angle CAB measures about 90 degrees.
- Angle FDE measures about 80 degrees, since it's a little less than a right angle.
- Angle GHI measures about 95 degrees, since it's a little more than a right angle.
- Angle JKL measures about 180 degrees.
- Angle MNO measures about 175 degrees, since it's a little less than a straight angle.
- Angle PQR measures about 185 degrees, since it's a little more than a straight angle.
- Angle STU measures about 270 degrees. Angle VWZ measures about 355 degrees since it's almost a full rotation.

Activity Synthesis

Select previously identified students to share an estimate of the degree measure for each angle; record and display their responses for all to see. Poll the class if they agree or disagree after each one.

After each of the angles is discussed, ask students what tools they might use to check their answers themselves. If/when a protractor is mentioned, ask how they could use it to find the measure of angles like STU or VWZ when the protractors usually only go to 180. (For example, they could find the measure of the angle that is less than 180, and subtract it from 360.)

2.2 Cutting Rectangles

10 minutes

The purpose of this activity is to provide a tangible experience with complementary and supplementary angles, which will be formally defined in the next activity. Students cut sheets of paper in two ways to see the decomposition of straight and right angles. In later activities and lessons, students will continue working with the fact that specific angles can be composed to make straight or right angles as a strategy for finding the measure of an unknown angle. In this activity, the language and vocabulary that students use during this task should be allowed to be loose as we will develop it more precisely in the following activities and lessons.

This activity gives students another opportunity to practice using a protractor to measure angles. Especially when students are measuring the angles they cut from the straight angle, it should be readily apparent if they are reading their angle from the wrong side of the protractor. For example, if students think that both of their angles measure 140 degrees, the papers can be positioned on top of each other to show that it is unreasonable to conclude that both angles have the same measure.

As students work on the task, monitor for students whose angle measures sum to exactly 180 degrees (and exactly 90 degrees) and students whose measures sum close to 180 degrees (and close to 90 degrees).

It is recommended **not** to show this image to students or they may try to copy the image rather than making their cut in different ways, but it is included here to clarify the instructions.

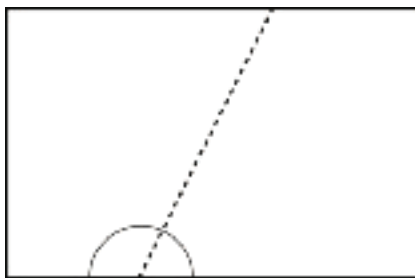

Addressing

- 7.G.B.5

Instructional Routines

- MLR3: Clarify, Critique, Correct

Launch

Distribute two half-sheets of blank paper per student and provide access to straightedges, scissors, and protractors. Emphasize that students should use a straightedge to draw the line they will cut along before they use scissors. Give students 3–5 minutes of quiet work time followed by a whole-class discussion.

Representation: Develop Language and Symbols. Use virtual or concrete manipulatives to connect symbols to concrete objects or values. Provide handouts of an angle representation for students to draw on or highlight and measure.

Supports accessibility for: Visual - Spatial Processing; Conceptual processing

Access for English Language Learners

Reading, Conversing: MLR3: Clarify, Correct and Critique. Display a sample student response that illustrates improper placement of the protractor that results in inaccurate measures or measures that are greater than 180 degrees when summed. Ask students to work with a partner to identify any errors, and to talk possible reasons for them. Invite students write a corrected response based on their conversation. Improved statements should include reference to the proper placement of protractors and how to determine measures with protractors. This helps students evaluate, and improve on, the written mathematical arguments of others.

Design Principle(s): Support sense-making; Maximize meta-awareness

Anticipated Misconceptions

Some students may want to make their first cut perpendicular to the side of the paper that they are cutting from. This could make it harder for them to notice the pattern that their two angles sum to 180 degrees. Encourage them to cut at a different angle.

Some students may struggle to position their protractor correctly to measure each cut piece. Prompt them to position the point that represents the center of the protractor on the vertex of their angle and line up the 0 on their protractor with one side of the angle, so that they can measure to the other side.

Some students may get angle measures that do not add up to exactly 180 (or 90) degrees. If the sum is close to 180 (or 90) degrees, this should be allowed during the work time and discussed during the activity synthesis. If the sum is not close to 180 (or 90), ask students to show you how they lined up the protractor to measure their angles.

Student Task Statement

Your teacher will give you two small, rectangular papers.

1. On one of the papers, draw a small half-circle in the middle of one side.



2. Cut a straight line, starting from the center of the half-circle, all the way across the paper to make 2 separate pieces. (Your cut does not need to be perpendicular to the side of the paper.)
3. On each of these two pieces, measure the angle that is marked by part of a circle. Label the angle measure on the piece.
4. What do you notice about these angle measures?
5. Clare measured 70 degrees on one of her pieces. Predict the angle measure of her other piece.
6. On the other rectangular paper, draw a small quarter-circle in one of the corners.



7. Repeat the previous steps to cut, measure, and label the two angles marked by part of a circle.
8. What do you notice about these angle measures?
9. Priya measured 53 degrees on one of her pieces. Predict the angle measure of her other piece.

Student Response

- 1-3. Answers vary.
4. The two angle measures should sum to 180° .
5. Clare's other angle should measure 110° , because $70 + 110 = 180$.
- 6-7. Answers vary.
8. The two angle measures should sum to 90° .

9. Priya's other angle should measure 37° , because $53 + 37 = 90$.

Activity Synthesis

Select previously identified students to share their angle measures within the decomposed straight angle. Record each answer displayed for all to see and ask:

- "What do you notice about the pairs of angle measures?" (They all sum to about 180 degrees.)
- "Why do you think this is?" (They started out as a straight angle and were cut apart.)
- "Why do you think some people got measurements that do not sum to exactly 180 degrees?" (measurement error)

Poll the class on the measure of Clare's second angle. Invite students to share different strategies they used. It is not important to formalize a process for solving supplementary angles at this point, because that will be addressed more in the next activity.

Select previously identified students to share their angle measures within the decomposed right angle. Record each answer displayed for all to see and ask similar questions as before to guide students to articulate that these pairs of angles should sum to 90 degrees.

Ask students to think about how they solved for the measure of Priya's second angle compared to how they solved for the measure of Clare's second angle. "What was the same, and what was different?"

- The process of using one known angle and what they should both add up to was the same.
- The sums were different: 180 for Clare's angles and 90 for Priya's angles.

2.3 Is It a Complement or Supplement?

10 minutes

In this activity, students begin to formalize a process for finding the measures of angles that are complements and supplements of angles with known measures. After they have worked on the activity and shared their solutions, they are introduced to the vocabulary terms **complementary** and **supplementary**. Complementary describes angles whose measures sum to 90 degrees and supplementary describes angles whose measures sum to 180 degrees.

Monitor for students who use or explain different ways to calculate the unknown angle measure. For example, when finding the measure of angle KOM , some might write $38 + x = 180$ and some might write $180 - 38$.

Addressing

- 7.G.B.5

Instructional Routines

- MLR8: Discussion Supports

Launch

Remind students that in the previous activity they used straight angles and right angles to help figure out unknown angle measures. In this activity, they are doing something similar but must figure out the unknown angle measure without a protractor.

Arrange students in groups of 2. Give students 3–4 minutes of quiet work time, followed by a partner and whole-class discussion.

Access for Students with Disabilities

Representation: Develop Language and Symbols. Create and maintain charts to display definitions and examples of complementary angles and supplementary angles.

Supports accessibility for: Conceptual processing; Memory

Anticipated Misconceptions

If students get stuck on the first problem, ask them what measurement do angles BCA and ACD have to add up to. This should get them started noticing the relationships between all the angles involved.

Student Task Statement

1. Use the protractor in the picture to find the measure of angles BCA and BCD .

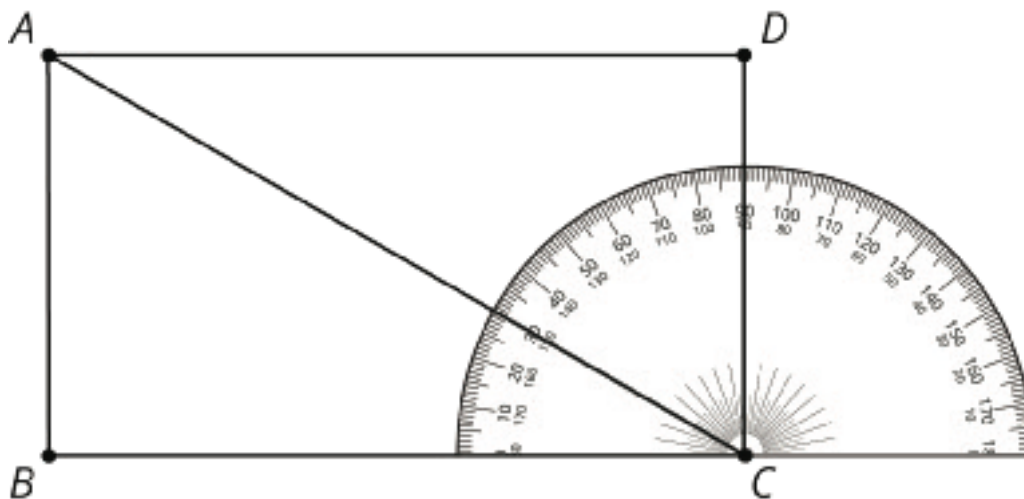

2. Explain how to find the measure of angle ACD without repositioning the protractor.
3. Use the protractor in the picture to find the measure of angles LOK and LOM .

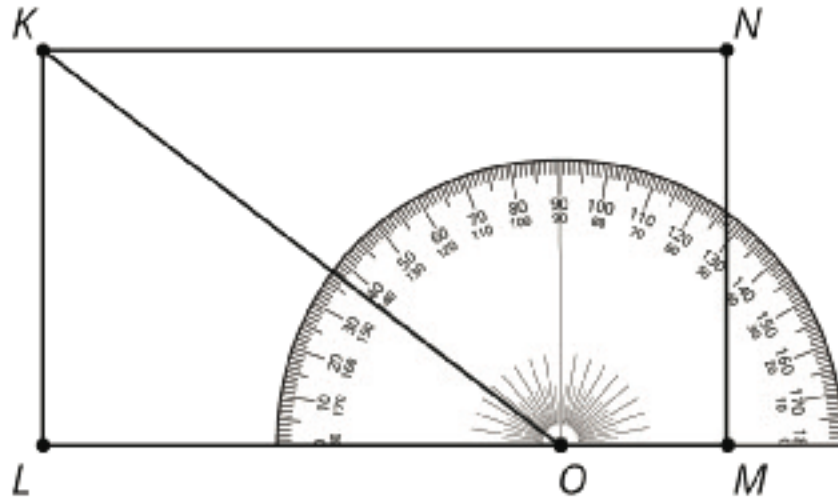

4. Explain how to find the measure of angle KOM without repositioning the protractor.

5. Angle BAC is a right angle. Find the measure of angle CAD .

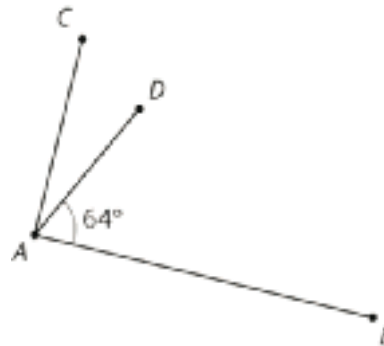

6. Point O is on line RS . Find the measure of angle SOP .

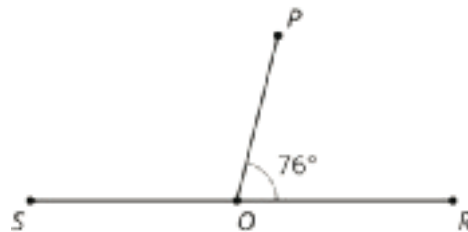

Student Response

1. Angle BCA has a measure of 30 degrees. Angle BCD has a measure of 90 degrees.
2. Angle ACD has a measure of 60 degrees since it is the angle left when angle BCA is removed from angle BCD and $90 - 30 = 60$.
3. Angle LOK has a measure of 37 degrees. Angle LOM has a measure of 180 degrees.
4. Angle KOM is 143 degrees since that is what is left when removing angle LOK from angle LOM and $180 - 37 = 143$.
5. 26° since $90 - 64 = 26$.

6. 104° since $180 - 76 = 104$

Are You Ready for More?

Clare started with a rectangular piece of paper. She folded up one corner, and then folded up the other corner, as shown in the photos.



1. Try this yourself with any rectangular paper. Fold the left corner up at any angle, and then fold the right corner up so that the edges of the paper meet.
2. Clare thought that the angle at the bottom looked like a 90 degree angle. Does yours also look like it is 90 degrees?
3. Can you explain why the bottom angle *always has to be* 90 degrees? Hint: the third photo shows Clare's paper, unfolded. The crease marks have dashed lines, and the line where the two paper edges met have a solid line. Mark these on your own paper as well.

Student Response

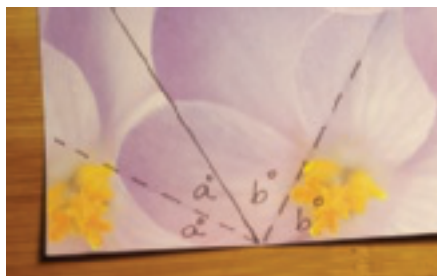

Since they were made by folding, there are two sets of angles with equal measures. Label them a° and b° . Since these four angles are adjacent and lie along a line, it must be true that $a + a + b + b = 180$, or $2a + 2b = 180$. Factoring gives $2(a + b) = 2 \cdot 90$. Therefore, it must be true that $a + b = 90$.

Activity Synthesis

The goal of this discussion is to introduce students to the terms complementary and supplementary for describing relationships between pairs of angles.

First, have students compare answers and strategies for the last two questions with their partners.

Next, display the last two questions for all to see and ask:

- “Which other problem in this activity was similar to the third question? How?” (The first problem, about angle ACD , also involved subtracting from 90.)
- “Which other problem in this activity was similar to the last question? How?” (The second problem, about angle KOM , also involved subtracting from 180.)

Explain to students that the term **complementary** describes a pair of angles whose measures sum to 90 degrees, and the term **supplementary** describes a pair of angles whose measures sum to 180 degrees. It is not important at this point to discuss that complementary or supplementary angles do not need to be adjacent, as that will be explored in the next lesson. Ask:

- “Which angles in this activity were supplementary angles?” (angles SOP and POR in the last question, as well as angles LOK and KOM from the second question)
- “Which angles in this activity were complementary angles?” (angles CAD and DAB in the third question, as well as from the first question angles ACD and BCA or angles DAC and BAC , or even from the second question angles OKN and OKL)

Invite students to continue practicing using the words *complementary* and *supplementary* throughout the rest of this unit, so they can start to feel more comfortable using them in their vocabulary.

Access for English Language Learners

Speaking: MLR8 Discussion Supports. Provide the following sentence frames to support student use of the words *complementary* and *supplementary*: “Angles ___ and ___ are complementary angles because . . .” and “Angles ___ and ___ are supplementary angles because . . .” Some students may also benefit from choral repetition of these phrases. This will give all students an opportunity to practice these new words in context.

Design Principle(s): Support sense-making; Maximize meta-awareness

Lesson Synthesis

- What does it mean for two angles to be supplementary? (Their measures sum to 180° .)
- What does it mean for two angles to be complementary? (Their measures sum to 90° .)
- If you know two angles are supplementary and you know the measure of one angle, how can you find the other? (Subtract the known one from 180° .)

Display diagrams and definitions of new vocabulary somewhere in the classroom so that students can refer back to them during subsequent lessons. As the unit progresses, new terms can be added.

2.4 Finding Measurements

Cool Down: 5 minutes

Addressing

- 7.G.B.5

Student Task Statement

1. Point F is on line CD . Find the measure of angle CFE .



2. Angle SPR and angle RPQ are complementary. Find the measure of angle RPQ .

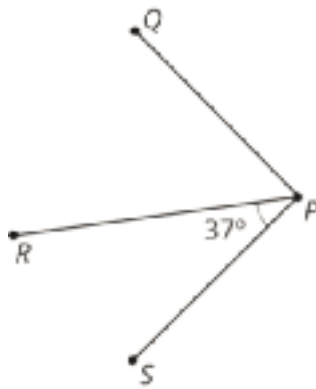

Student Response

1. Angle CFE is 28 degrees because $180 - 152 = 28$.
2. Angle RPQ is 53 degrees because $90 - 37 = 53$

Student Lesson Summary

If two angle measures add up to 90° , then we say the angles are **complementary**. Here are three examples of pairs of complementary angles.

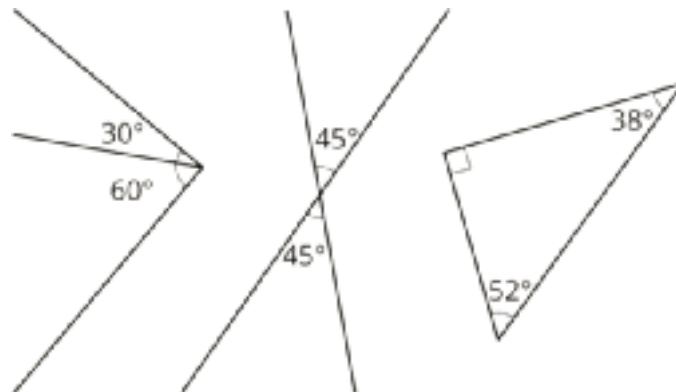

If two angle measures add up to 180° , then we say the angles are **supplementary**. Here are three examples of pairs of supplementary angles.

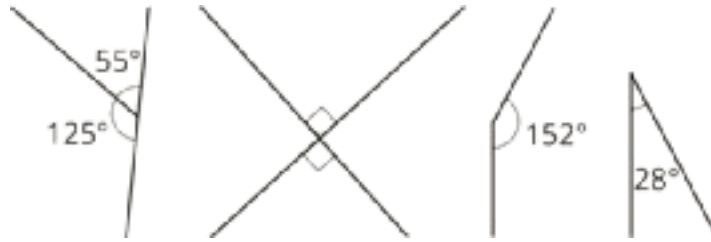

Glossary

- complementary
- supplementary

Lesson 2 Practice Problems

Problem 1

Statement

Angles A and C are supplementary. Find the measure of angle C .

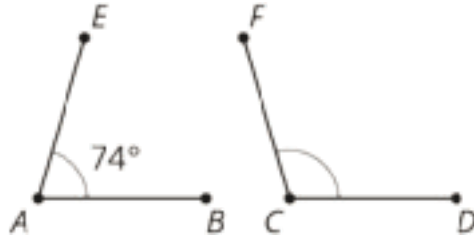

Solution

106°

Problem 2

Statement

- List two pairs of angles in square $CDFG$ that are complementary.
- Name three angles that sum to 180° .

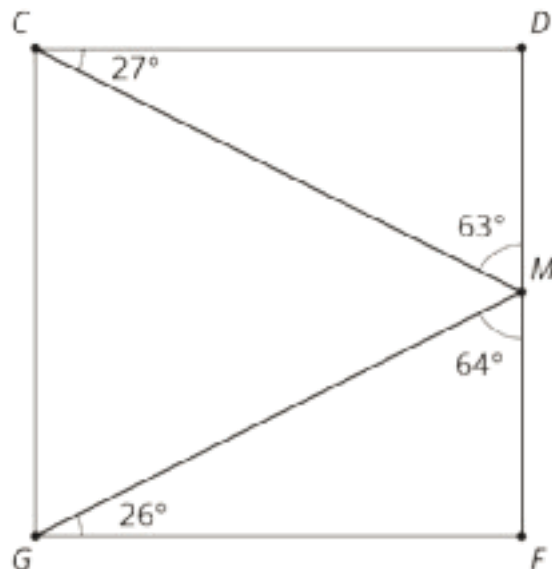

Solution

- Any 2 of these pairs: Angles DCM and MCG , angles MGF and MGC , angles MGF and GMF , or angles DCM and DMC .
- Any 1 of these sets: Angles DMC , CMG , and GMF , angles FGM , GMF , and MFG , angles CDM , DMC , and MCD , or angles MCG , CGM , and GMC .

Problem 3

Statement

Complete the equation with a number that makes the expression on the right side of the equal sign equivalent to the expression on the left side.

$$5x - 2.5 + 6x - 3 = \underline{\quad}(2x - 1)$$

Solution

5.5

(From Unit 6, Lesson 22.)

Problem 4

Statement

Match each table with the equation that represents the same proportional relationship.

A.

| x | y |
|-----|-----|
| 2 | 8 |
| 3 | 12 |
| 4 | 16 |
| 5 | 20 |

1. $y = 1.5x$

2. $y = 1.25x$

3. $y = 4x$

B.

| x | y |
|-----|------|
| 3 | 4.5 |
| 6 | 9 |
| 7 | 10.5 |
| 10 | 15 |

C.

| x | y |
|-----|----------------|
| 2 | $\frac{5}{2}$ |
| 4 | 5 |
| 6 | $\frac{15}{2}$ |
| 12 | 15 |

Solution

○ A: 3

○ B: 1

○ C: 2

(From Unit 2, Lesson 4.)

Lesson 3: Nonadjacent Angles

Goals

- Comprehend the term “vertical angles” (in spoken and written language) refers to a pair of angles created by two intersecting lines.
- Generalize (orally and in writing) that the opposite angles created by two intersecting lines have equal angle measures.
- Use reasoning about angle measures to identify complementary or supplementary angles that are not adjacent.

Learning Targets

- I can determine if angles that are not adjacent are complementary or supplementary.
- I can explain what vertical angles are in my own words.

Lesson Narrative

In this lesson, students see that angles do not need to be adjacent to be complementary or supplementary. Students are also introduced to and begin to use the term **vertical angles** for describing the opposite angles formed when two lines cross (MP6). They examine multiple examples and see that the vertical angles have equal measures. Students can relate this understanding to the fact that both angles in a pair of vertical angles are supplementary to the same angle in between, but in grade 7 students do not need to be able to give a formal geometric proof that vertical angles must have equal measures. As students see different ways of making pairs of supplementary angles in two lines crossing, they engage in MP7.

Alignments

Addressing

- 7.EE.A: Use properties of operations to generate equivalent expressions.
- 7.G.B.5: Use facts about supplementary, complementary, vertical, and adjacent angles in a multi-step problem to write and solve simple equations for an unknown angle in a figure.

Instructional Routines

- MLR2: Collect and Display
- MLR8: Discussion Supports
- Think Pair Share

Required Materials

Geometry toolkits

For grade 6: tracing paper, graph paper, colored pencils, scissors, and an index card to use as a straightedge or to mark right angles.

For grades 7 and 8: everything in grade 6, plus a ruler and protractor. Clear protractors with no holes and with radial lines printed on them are recommended.

Notes: (1) "Tracing paper" is easiest to use when it's a smaller size. Commercially-available "patty paper" is 5 inches by 5 inches and ideal for this. If using larger sheets of tracing paper, consider cutting them down for student use. (2) When compasses are required in grades 6-8 they are listed as a separate Required Material.

Student Learning Goals

Let's look at angles that are not right next to one another.

3.1 Finding Related Statements

Warm Up: 5 minutes

In the previous unit, students worked extensively with writing equations in equivalent forms, for example, rewriting $2x + 50 = 7$ as $2x = 7 - 50$. A new wrinkle here is that each equation has two variables. Equations with more than one variable will be studied extensively in grade 8, but here we are using the concrete context of geometry to help make sense of it.

The purpose of this warm-up is for students to use structure to reason about equivalent equations. In this unit, students will write equations to represent how angles are related to each other, and this warm-up helps prepare for that work.

All of the given statements *could* be true so students may be quick to say each of them *must* be true. Ask these students if there is a case when that particular statement would not be true for possible values for a and b . As students discuss their responses with a partner, monitor for students who correctly answered each question to share during the whole-class discussion.

Addressing

- 7.EE.A

Launch

Arrange students in groups of 2.

Ask students, "If we know for sure that $a + b = 180$, what are some possible values of a and b ?" Give students 30 seconds of quiet think time, and then ask several students to share their responses. Some examples are $a = 90$ and $b = 90$, $a = 0$ and $b = 180$, and $a = 10$ and $b = 170$. Tell students that in this activity, we know for sure that $a + b = 180$, but we don't know the exact values of a and b .

Give students 2 minutes of quiet work time followed by 1 minute to discuss their responses with a partner. Follow with a whole-class discussion.

Anticipated Misconceptions

Some students may assume a and b both have a value of 90. Explain that this *may* be true, but that it is also possible that a and b are not equal to each other.

Student Task Statement

Given a and b are numbers, and $a + b = 180$, which statements also must be true?

$$a = 180 - b$$

$$a - 180 = b$$

$$360 = 2a + 2b$$

$$a = 90 \text{ and } b = 90$$

Student Response

1. True. Students might reason inductively using several examples or draw a diagram showing the relationship between a , b , and 180.
2. Not always true ($a = 90$ and $b = 90$, for example), but could be true ($a = 180$ and $b = 0$).
3. True. The equation can be rewritten $2 \cdot 180 = 2(a + b)$ using the distributive property. Since twice 180 and twice $a + b$ are equal, it must be true that 180 and $a + b$ are equal.
4. Not always true ($a = 100$ and $b = 80$ for example), but could be true.

Activity Synthesis

Select previously identified students to explain their reasoning for each statement. Poll the class if they agree or disagree after each student shares. If students disagree, allow students to discuss until they come to an agreement. Consider asking some of the following questions while students discuss:

- “Do you have an example that might support this statement being true (or untrue)?”
- “What evidence do you have to support that statement being true (or untrue)?”
- “What other values of a and b might work?”
- “What was done to the equation to make the statement true (or untrue)?”

If any of the answers the students decide upon are incorrect, give an example of when the statement would not be true.

3.2 Polygon Angles

10 minutes

In this activity, students see that angles do not need to be adjacent to each other in order to be considered complementary or supplementary. Students are given two different polygons and are asked to find complementary and supplementary angles, using any tools in their geometry toolkit. The most likely approaches are:

- measure each angle with a protractor and look for any that sum to 180 or 90 degrees.

- trace the legs of an angle with tracing paper and align its vertex and one leg with another angle to see if the two angles, when adjacent, form a straight angle or a right angle.

As students work, monitor for students who use either approach listed or some other strategy. Also, encourage students to use precise vocabulary and language that they learned in previous activities and lessons (MP6).

Addressing

- 7.G.B.5

Instructional Routines

- MLR8: Discussion Supports

Launch

Remind students that in the previous lesson they learned the meaning of *complementary* and *supplementary* when describing angles. Invite students to share their definitions of the words and consider displaying the meanings for all to see through the remainder of the class. If students include in their definitions the idea that the angles need to be adjacent (for example, that they “make a straight line” or “make a right angle”), point out that while that was true for all the examples they have seen so far, that was *not* a part of the definition. Explain that angles do not need to be adjacent to one another to be complementary or supplementary. They just have to sum to 90 or 180 degrees.

Keep students in the same groups. Provide access to geometry toolkits. Give students 3–4 minutes of quiet work time, followed by partner and whole-class discussions.

Access for Students with Disabilities

Action and Expression: Internalize Executive Functions. Provide students with a printed enlarged version of the figures in the student task statement.

Supports accessibility for: Language; Organization

Anticipated Misconceptions

Some students may struggle to use a protractor to measure angles when the rays are not drawn long enough to reach the edge of the protractor. Prompt them to extend the sides of the angle using a straightedge.

Student Task Statement

Use any useful tools in the geometry toolkit to identify any pairs of angles in these figures that are complementary or supplementary.

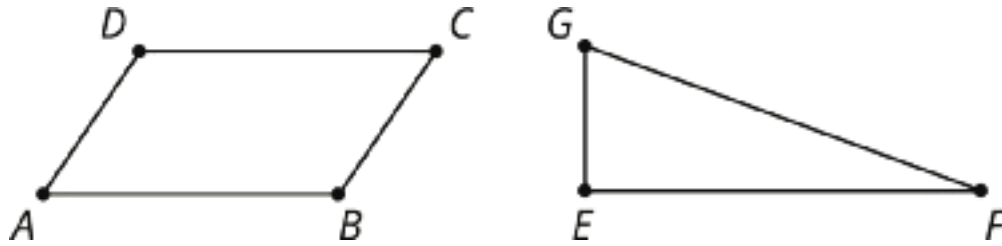

Student Response

- In the quadrilateral, there are four pairs of supplementary angles:
 - Angle BAD is supplementary with angle ABC .
 - Angle BAD is also supplementary with angle ADC .
 - Angle BCD is supplementary with angle ABC .
 - Angle BCD is also supplementary with angle ADC .
- In the triangle, there is one pair of complementary angles: angle EFG is complementary with angle EGF .

Activity Synthesis

Select previously identified students to share their answers and reasoning. If possible, have a student demonstrate each method for finding pairs of angles: measuring with a protractor or using tracing paper. Ensure that correct use of a protractor to find the measure of an angle is clearly and carefully demonstrated. This will help all students prepare for the next activity where everyone will be using a protractor.

Access for English Language Learners

Speaking: MLR8 Discussion Supports. Use this routine to support whole-class discussion. After each student demonstrates a method for finding pairs of angles (measuring with a protractor or using tracing paper), invite students to turn to a partner to restate what they heard, using precise mathematical language. Select one or two students to share with the class. Ask the original speaker if their peer was accurately able to restate their method. This will provide more students with an opportunity to describe methods for finding pairs of angles using mathematical language.

Design Principle(s): Support sense-making

3.3 Vertical Angles

15 minutes

The purpose of this activity is for students to learn about **vertical angles**. Each student draws two intersecting lines and measures the four resulting angles. Then, students examine multiple examples to come up with a conjecture for any relationships they noticed (MP8). Because of the focus of the previous activity, students will likely notice that there are adjacent supplementary angles in their drawings. Encourage them to look for any *other* patterns they can find.

Addressing

- 7.G.B.5

Instructional Routines

- MLR2: Collect and Display

Launch

Arrange students in groups of 2–4. Provide access to geometry toolkits.

Ask students to read the task statement quietly to themselves. Then, ask them to read it again and underline any words that they are uncertain about. Invite students to share any words they underlined and record them for all to see. Before students start working, explain the meaning of any word they identified, which may include:

- *intersecting*—Some students may think that “intersecting” means “perpendicular.” In this activity, it is important for students to examine some examples of vertical angles made by intersecting lines that are *not* perpendicular. Consider holding up two meter sticks to demonstrate several examples of two lines that intersect versus two lines that do not intersect. Clarify that intersecting lines do not have to be perpendicular.
- *conjecture*—Explain that a conjecture is a statement we *think* is true but aren’t certain about. It is more than just a guess. A conjecture could be a guess that is based on some evidence.

Give students 2–3 minutes to draw and measure the figure. Remind them to draw arcs to label the degree measures of their angles. Follow with small-group and whole-class discussions.

Access for Students with Disabilities

Representation: Develop Language and Symbols. Create and maintain charts to display definitions and examples of vertical angles, intersecting lines, and conjectures.

Supports accessibility for: Conceptual processing; Memory

Access for English Language Learners

Speaking: MLR2 Collect and Display. As students work, listen for and collect vocabulary, gestures, and phrases that students use to describe the relationships they notice between angles (e.g., equivalent, adjacent, right, straight, complementary and supplementary angles, etc.). Organize the responses onto a visual display. Throughout the remainder of the lesson, continue to update the display and remind students to use the display as a resource if needed. During the lesson synthesis, after the term “vertical angles” is introduced, ask students to identify any language on the display that could be used to describe vertical angles.

Design Principle(s): Optimize output (for explanation); Maximize meta-awareness

Anticipated Misconceptions

Some students may label the angle measures toward the end of the rays, where they read the number from the protractor. This is not precise enough, because two different angles share each ray. Remind students about drawing arcs to clarify which angle they measured.

Student Task Statement

Use a straightedge to draw two intersecting lines. Use a protractor to measure all four angles whose vertex is located at the intersection.

Compare your drawing and measurements to the people in your group. Make a conjecture about the relationships between angle measures at an intersection.

Student Response

Answers vary. Possible conjecture: “The angles across from each other will always be equal.”

Activity Synthesis

The goal of this discussion is for students to see that two intersecting lines form vertical angles, and the angles across from each other are congruent. Select students to share their conjectures. If there are students who can use supplementary angles to explain why vertical angles have equal measures, put them last in the sequence.

Define **vertical angles** as a pair of angles, formed by two intersecting lines, that are opposite each other.

Display the image and ask students to identify four pairs of vertical angles. In particular, students may have trouble seeing that angles FJI and HJG are vertical angles.

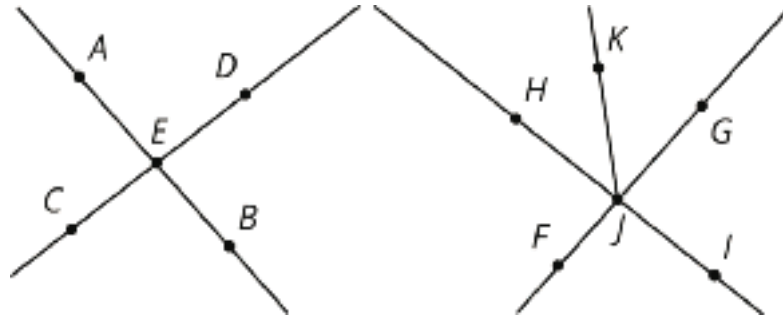

Although students don't need to know a proof that vertical angles always have the same measure, it may be helpful to show one way to understand why they are. In the image. . .

- Angles AED and AEC are supplementary, so the sum of their measures is 180 degrees.
- Angles AEC and CEB are also supplementary, so the sum of their measures is also 180 degrees.
- If we take angle AEC away from the straight angles, we see that angles AED and CEB must have the same measure.

3.4 Row Game: Angles

Optional: 10 minutes

This activity gives students an opportunity to practice recognizing complementary, supplementary, and vertical angles and using what they know about those types of angles to find unknown angle measures. Some students may feel comfortable writing equations to show their reasoning, but it is not important that all students use this strategy at this point, as it will be the focus of future lessons. Encourage students to continue using the new vocabulary.

Addressing

- 7.G.B.5

Instructional Routines

- MLR8: Discussion Supports
- Think Pair Share

Launch

Arrange students in groups of 2. Make sure students know how to play a row game. Give students 5–6 minutes of partner work time followed by a whole-class discussion.

Anticipated Misconceptions

If students struggle to see relationships of angles in figures, prompt students to look for complementary, supplementary, or vertical angles.

Student Task Statement

Find the measure of the angles in one column. Your partner will work on the other column. Check in with your partner after you finish each row. Your answers in each row should be the same. If your answers aren't the same, work together to find the error and correct it.

column A

P is on line m . Find the value of a .

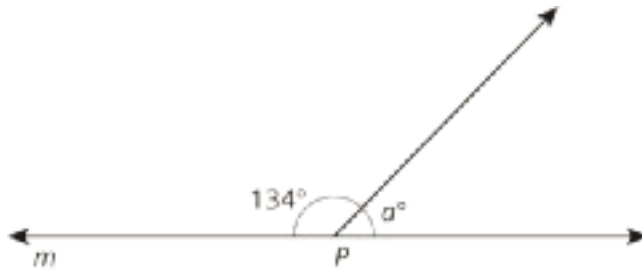

Find the value of a .

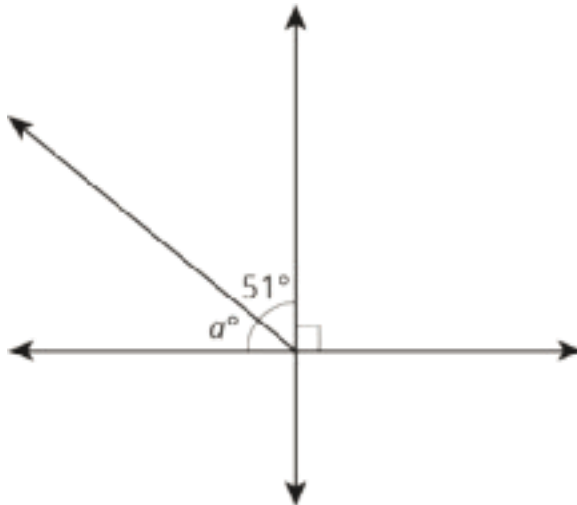

column A

column B

Find the value of b .

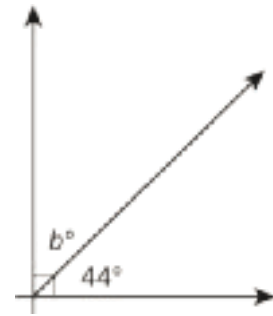

In right triangle LMN , angles L and M are complementary. Find the measure of angle L .

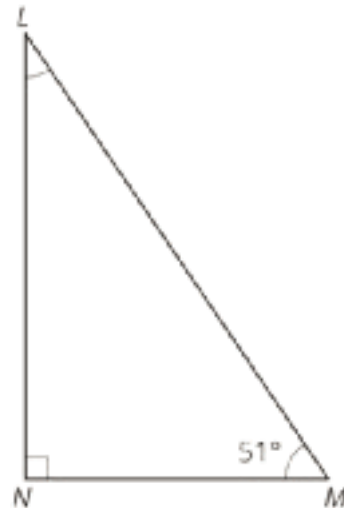

column B

Angle C and angle E are supplementary. Find X is on line WY . Find the value of b . the measure of angle E .

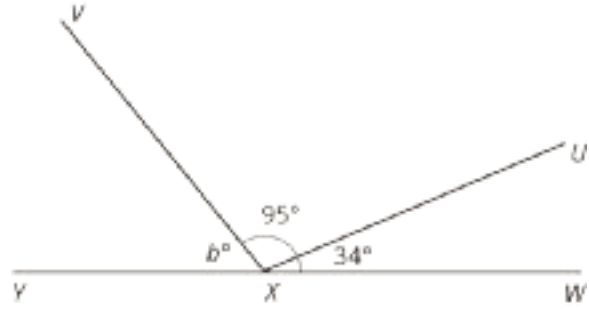
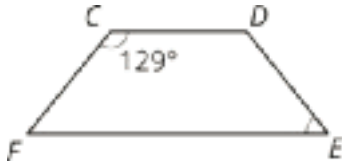

Find the value of c .

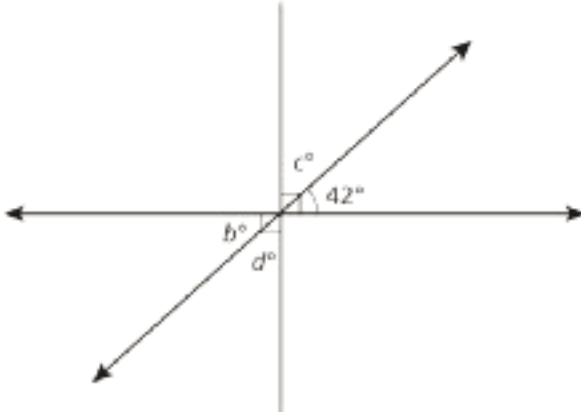

B is on line FW . Find the measure of angle CBW .

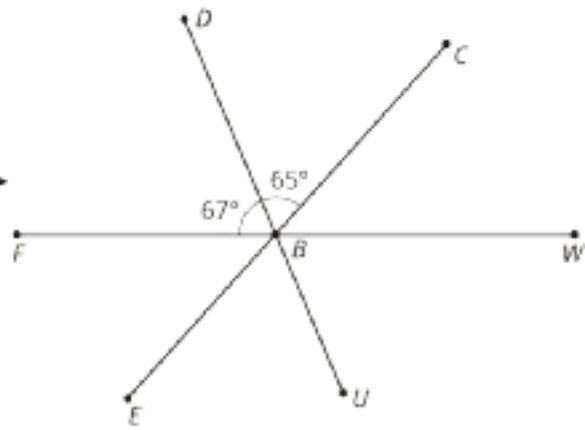

Two angles are complementary. One angle measures 37 degrees. Find the measure of other angle.

Two angles are supplementary. One angle measures 127 degrees. Find the measure of the other angle.

Student Response

1. 46 degrees
2. 39 degrees
3. 51 degrees
4. 48 degrees
5. 53 degrees

Activity Synthesis

Ask students, "Were there any rows that you and your partner did not get the same answer?" Invite students to share how they came to an agreement on the final answer for the problems in those rows.

Consider asking some of the following questions:

- “Did you and your partner use the same strategy for each row?”
- “What was the same and different about both of your strategies?”
- “Did you learn a new strategy from your partner?”
- “Did you try a new strategy while working on these questions?”

Access for English Language Learners

Speaking: MLR8 Discussion Supports. Use this routine to support students as they describe their strategies for calculating the unknown angle to their partner. Provide sentence frames such as, “I noticed that ____, so I . . .” or “First, I ____ because . . .” Encourage students to consider what details are important to share and to think about how they will explain their reasoning using mathematical language. Listen for students who refer to the relationships between angles and those who identify complementary, supplementary, or vertical angles.

Design Principle(s): Optimize output (for explanation)

Lesson Synthesis

- Do supplementary or complementary angles need to be next to one another? (No.) Think of examples where they are not.
- What are vertical angles? (A pair of angles across from one another where two lines cross.)
- What is true about the measures of vertical angles? (The measures are always the same.)

Display diagrams and definitions of new vocabulary somewhere in the classroom so that students can refer back to them during subsequent lessons. “Vertical angles” is new vocabulary; you might consider also adding “intersecting lines” and “conjecture.” As the unit progresses, new terms can be added.

3.5 Finding Angle Pairs

Cool Down: 5 minutes

Addressing

- 7.G.B.5

Launch

Make sure students realize that when a question says “two pairs” it is referring to a total of 4 angles.

Student Task Statement

1. Name *two pairs* of complementary angles in the diagram.
2. Name *two pairs* of supplementary angles in the diagram.
3. Draw another angle to make a pair of vertical angles. Label your new angle with its measure.

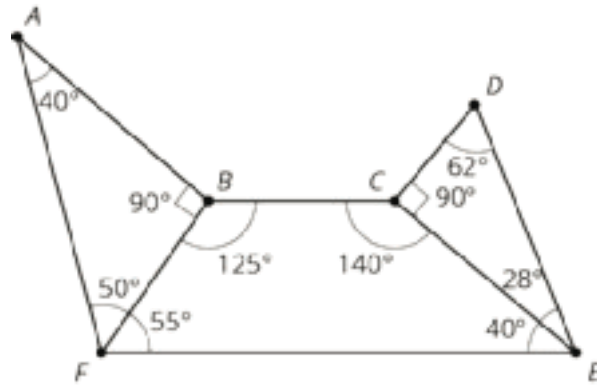

Student Response

1. Any two of: Angles BAF and AFB , angles CDE and DEC , or angles CEF and AFB .
2. Any two of: Angles ABF and DCE , angles FBC and BFE , angles BCE and CEF , or angles BCE and BAF .
3. Answers vary. Extending any two intersecting segments will create a vertical angle that has a measure the same as the angle before extending.

Student Lesson Summary

When two lines cross, they form two pairs of **vertical angles**. Vertical angles are across the intersection point from each other.

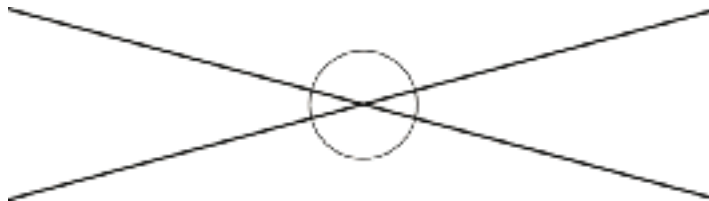

Vertical angles always have equal measure. We can see this because they are always supplementary with the same angle. For example:

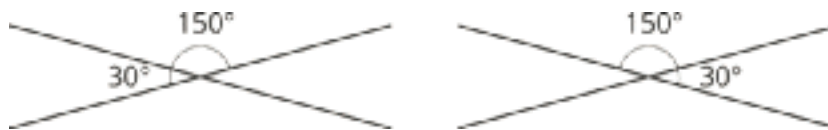

This is always true!

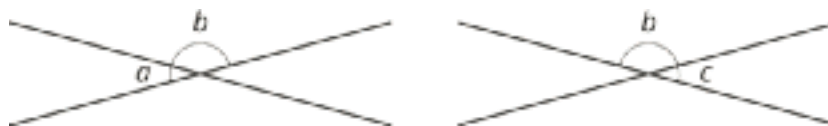

$$a + b = 180 \text{ so } a = 180 - b.$$

$c + b = 180$ so $c = 180 - b$.

That means $a = c$.

Glossary

- vertical angles

Lesson 3 Practice Problems

Problem 1

Statement

Two lines intersect. Find the value of b and c .

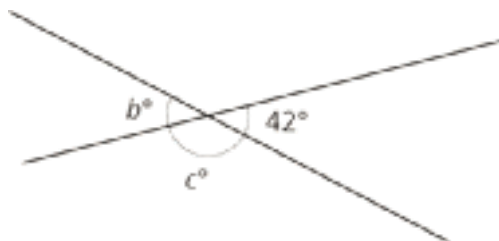

Solution

$$c = 138, b = 42$$

Problem 2

Statement

In this figure, angles R and S are complementary. Find the measure of angle S .

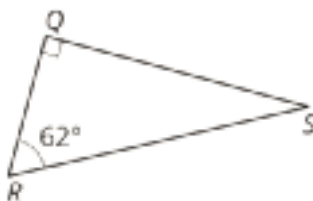

Solution

$$28^\circ$$

Problem 3

Statement

If two angles are both vertical and supplementary, can we determine the angles? Is it possible to be both vertical and complementary? If so, can you determine the angles? Explain how you know.

Solution

Yes, they are both possible. Vertical and supplementary angles must be 90° each, because the two angles must be the same and sum to 180° . Vertical and complementary angles must be 45° , because the two angles must be the same and sum to 90° .

Problem 4

Statement

Match each expression in the first list with an equivalent expression from the second list.

A. $5(x + 1) - 2x + 11$

1. $\frac{1}{4}x - 8$

B. $2x + 2 + x + 5$

2. $\frac{1}{2}(6x + 14)$

C. $\frac{-3}{8}x - 9 + \frac{5}{8}x + 1$

3. $11(9x + 4)$

D. $2.06x - 5.53 + 4.98 - 9.02$

4. $3x + 16$

E. $99x + 44$

5. $2.06x + (-5.53) + 4.98 + (-9.02)$

Solution

- A: 4
- B: 2
- C: 1
- D: 5
- E: 3

(From Unit 6, Lesson 22.)

Problem 5

Statement

Factor each expression.

a. $15a - 13a$

b. $-6x - 18y$

c. $36abc + 54ad$

Solution

a. $a(15 - 13)$

b. $-6(1x + 3y)$ (or $6(-x - 3y)$)

c. $9a(4bc + 6d)$

(From Unit 6, Lesson 19.)

Problem 6

Statement

The directors of a dance show expect many students to participate but don't yet know how many students will come. The directors need 7 students to work on the technical crew. The rest of the students work on dance routines in groups of 9. For the show to work, they need at least 6 full groups working on dance routines.

- Write and solve an inequality to represent this situation, and graph the solution on a number line.
- Write a sentence to the directors about the number of students they need.

Solution

- $\frac{x-7}{9} \geq 6$, $x \geq 61$. The number line should have a closed circle at $x = 61$. Some students may start at $x = 61$ and draw a line with an arrow extending to the right; others may draw dots on integers to the right of $x = 61$.
- The directors need at least 61 students to show up. (Possibly, they may only be happy if they get 61, 70, 79, etc. students so they have even groups of nine.)

(From Unit 6, Lesson 17.)

Problem 7

Statement

A small dog gets fed $\frac{3}{4}$ cup of dog food twice a day. Using d for the number of days and f for the amount of food in cups, write an equation relating the variables. Use the equation to find how many days a large bag of dog food will last if it contains 210 cups of food.

Solution

$f = 1.5 \cdot d$ or equivalent. The bag will last 140 days since $210 \div 1.5 = 140$.

(From Unit 2, Lesson 5.)

Lesson 4: Solving for Unknown Angles

Goals

- Coordinate (orally and in writing) diagrams and equations that represent the same relationship between angle measures.
- Solve multi-step problems involving complementary, supplementary, and vertical angles, and explain (orally) the reasoning.

Learning Targets

- I can reason through multiple steps to find unknown angle measures.
- I can recognize when an equation represents a relationship between angle measures.

Lesson Narrative

In previous lessons, students solved single-step problems about supplementary, complementary, and vertical angles. In this lesson, students apply these skills to find unknown angle measures in multi-step problems. In the info gap activity, students keep asking questions until they get all the information needed to solve the problem. Then they see that they can represent angle problems with equations. As students work to construct arguments about angles and discuss them with their partners, they engage in MP3.

Alignments

Addressing

- 7.G.A: Draw, construct, and describe geometrical figures and describe the relationships between them.
- 7.G.B: Solve real-life and mathematical problems involving angle measure, area, surface area, and volume.
- 7.G.B.5: Use facts about supplementary, complementary, vertical, and adjacent angles in a multi-step problem to write and solve simple equations for an unknown angle in a figure.

Building Towards

- 7.G.B.5: Use facts about supplementary, complementary, vertical, and adjacent angles in a multi-step problem to write and solve simple equations for an unknown angle in a figure.

Instructional Routines

- MLR4: Information Gap Cards
- Think Pair Share
- True or False

Required Materials

Pre-printed slips, cut from copies of the **Instructional master**

Required Preparation

Make 1 copy of the Info Gap: Angle Finding Instructional master for every 2 students, and cut them up ahead of time.

Student Learning Goals

Let's figure out some missing angles.

4.1 True or False: Length Relationships

Warm Up: 5 minutes

The purpose of this warm-up is to have students express relationships between length measures with equations, in preparation for doing the same with angle measures in upcoming activities.

Addressing

- 7.G.A

Building Towards

- 7.G.B.5

Instructional Routines

- True or False

Launch

Remind students that we refer to a length of a segment by naming its endpoints. For example, AB means the length of the line segment from A to B .

Display one problem at a time. Tell students to give a signal when they have decided if the equation is true or false. Give students 1 minute of quiet think time followed by a whole-class discussion.

Student Task Statement

Here are some line segments.



Decide if each of these equations is true or false. Be prepared to explain your reasoning.

$$CD + BC = BD$$

$$AB + BD = CD + AD$$

$$AC - AB = AB$$

■ $BD - CD = AC - AB$

Student Response

1. True
2. False
3. False
4. True

Activity Synthesis

Ask students to share their reasoning for each equation. Record and display their responses for all to see. To involve more students in the conversation, consider asking:

- “Do you agree or disagree? Why?”
- “Who can restate ___’s reasoning in a different way?”
- “Does anyone want to add on to ____’s reasoning?”

After each true equation, ask students if they could rely on the same reasoning to determine if other similar problems are equivalent. After each false equation, ask students how the problem could be changed to make the equation true.

4.2 Info Gap: Angle Finding

20 minutes

The purpose of this info gap activity is for students to see how they can use different pieces of information to solve for an unknown angle measure in a multi-step problem. During the whole-class discussion, students are introduced to writing and solving equations to represent the relationships between angles.

The info gap structure requires students to make sense of problems by determining what information is necessary. This may take several rounds of discussion (MP1). Since there are many different pieces of information that *could* be used to solve the problem but are not given on the data card, consider using a variation on the typical info gap structure: Instead of the student with the problem card asking for specific pieces of information, the student with the data card chooses a piece of information to share, and the student with the problem card explains how they use that piece of information. If enough information hasn’t been given, the student with the data card chooses another piece of information to share.

You will need the Instructional master for this activity. Here is the text of the cards for reference and planning:

Angle Finding Info Gap - Problem Card 1:

Find the measure of angle b .

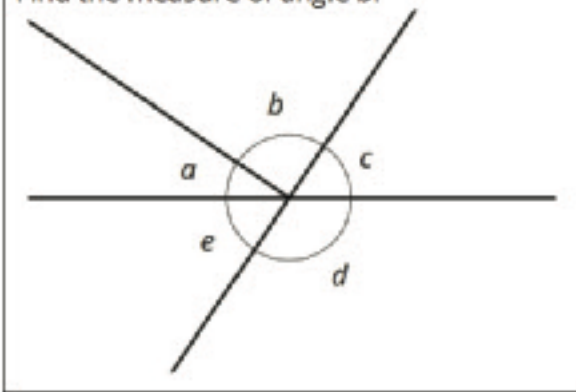

Angle Finding Info Gap - Data Card 1:

- Angles c and e are vertical angles.
- Angles a and c are complementary angles.
- The measure of angle $d = 124^\circ$.
- The measure of angle $c = 56^\circ$.

Angle Finding Info Gap - Problem Card 2:

Find the measure of angle b .

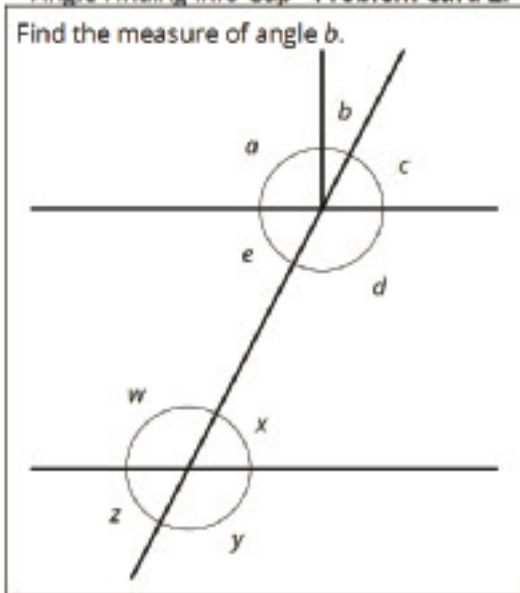

Angle Finding Info Gap - Data Card 2:

- The measure of angle $a = 90^\circ$.
- The measure of angle $z = 63^\circ$.
- Angles c and z are not vertical angles.
- Angles d and x are supplementary angles.

As students work, monitor for those who use different strategies or start with different pieces of information. Also, monitor for students who choose to show their reasoning by writing and solving equations.

Addressing

- 7.G.B.5

Instructional Routines

- MLR4: Information Gap Cards

Launch

If desired, explain this variation from the typical info gap: instead of the student with the problem card asking for each piece of information, the student with the data card chooses a piece of information to share. The student with the problem card still needs to explain how they can use each piece of information. If more information is needed to solve the problem, the student with the

data card chooses another piece of information to share. Also, students need to listen to their partner carefully because they may be asked to explain their partner's reasoning to the class.

Arrange students in groups of 2. Distribute a problem card to one student and a data card to the other student in each group.

Action and Expression: Internalize Executive Functions. Begin with a small-group or whole-class demonstration and think aloud of a sample situation problem card and data card to remind students how to use the info gap structure. Keep the worked-out equations and angle drawing on display for students to reference as they work.

Supports accessibility for: Memory; Conceptual processing

Access for English Language Learners

Conversing: Use this modified version of *MLR4 Information Gap* to give students an opportunity to discuss the information necessary to solve for an unknown angle measure. Display the follow sentence frames to support student discussion: "Can you tell me . . . (specific piece of information)", "Why do you need to know . . . (that piece of information)?", and "I can use this information to . . ."

Design Principle(s): Cultivate conversation

Anticipated Misconceptions

For the second set of cards, students may struggle to find the connection between the lower half of the figure and the upper half. Remind them that supplementary angles do not need to be next to one another, but they can be.

Student Task Statement

Your teacher will give you either a *problem card* or a *data card*. Do not show or read your card to your partner.

If your teacher gives you the *problem card*:

1. Silently read your card and think about what information you need to be able to answer the question.
2. Ask your partner for the specific information that you need.
3. Explain how you are using the information to solve the problem.

Continue to ask questions until you have enough information to solve the problem.

4. Share the *problem card* and solve the problem independently.
5. Read the *data card* and discuss your reasoning.

If your teacher gives you the *data card*:

1. Silently read your card.
2. Ask your partner “*What specific information do you need?*” and wait for them to *ask* for information.

If your partner asks for information that is not on the card, do not do the calculations for them. Tell them you don’t have that information.

3. Before sharing the information, ask “*Why do you need that information?*” Listen to your partner’s reasoning and ask clarifying questions.
4. Read the *problem card* and solve the problem independently.
5. Share the *data card* and discuss your reasoning.

Pause here so your teacher can review your work. Ask your teacher for a new set of cards and repeat the activity, trading roles with your partner.

Student Response

1. $b = 90^\circ$. Possible strategies:

- $c = 56, a = 90 - 56 = 34, b = 180 - 34 - 56 = 90$
- $d = 124, e = 180 - 124 = 56, c = 56, a = 90 - 56 = 34, b = 180 - 34 - 56 = 90$
- $a + c = 90, a + b + c = 180, b = 180 - 90 = 90$

2. $b = 27^\circ$. Possible strategies:

- $z = 63, x = 63, d = 180 - 63 = 117, c = 180 - 117 = 63, a = 90, b = 180 - 90 - 63 = 27$
- $z = 63, w = 180 - 63 = 117, x = 180 - 117 = 63, d = 180 - 63 = 117, e = 180 - 117 = 63, c = 63, a = 90, b = 360 - 117 - 63 - 90 - 63 = 27$

Activity Synthesis

The goal of this discussion is for students to see that writing and solving equations is an efficient strategy to show their reasoning about multi-step angle problems.

For each problem, select a student who had the information card to share their partner’s reasoning. Record their reasoning using equations and display for all to see. Listen carefully and make sure the

equation matches how they explain their reasoning. Here are some sample equations for the first problem.

solving for e given d

$$\begin{aligned} e + d &= 180 \\ e + 124 &= 180 \\ e &= 180 - 124 \\ e &= 56 \end{aligned}$$

solving for a given c

$$\begin{aligned} a + c &= 90 \\ a + 56 &= 90 \\ a &= 90 - 56 \\ a &= 34 \end{aligned}$$

solving for e given c

$$\begin{aligned} c &= 56 \\ e &= c \\ e &= 56 \end{aligned}$$

solving for b given that a and c are complementary

$$\begin{aligned} a + c &= 90 \\ a + b + c &= 180 \\ b + (a + c) &= 180 \\ b + 90 &= 180 \\ b &= 180 - 90 \\ b &= 90 \end{aligned}$$

Display the equations that represent different students' strategies side by side and have students contrast the different methods, for example, the difference between how two students worked the problem if one was given the measure of angle d first but the other was given the measure of angle c first.

4.3 What's the Match?

10 minutes

The purpose of this activity is for students to match relationships between angles in a figure with equations that can represent those relationships. This prepares students for writing and solving equations that represent relationships between angles in the next lesson. As students explain their reasoning, monitor for students who use the appropriate vocabulary and language (i.e. vertical angles have equal measures, supplementary angles sum to 180 degrees, etc.).

Addressing

- 7.G.B.5

Instructional Routines

- Think Pair Share

Launch

Keep students in same groups. Give students 2–3 minutes of quiet work time followed by partner and whole-class discussions.

Student Task Statement

Match each figure to an equation that represents what is seen in the figure. For each match, explain how you know they are a match.

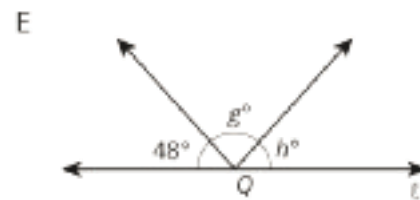
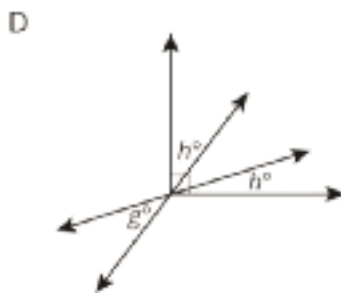
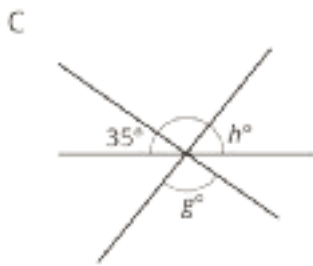
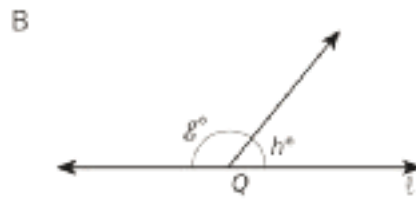
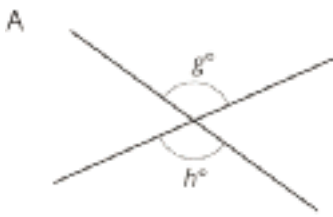

1. $g + h = 180$
2. $g = h$
3. $2h + g = 90$
4. $g + h + 48 = 180$
5. $g + h + 35 = 180$

Student Response

1. B (This is because g and h are supplementary angles, $g + h = 180$.)
2. A (g and h are vertical angles and vertical angles are congruent so $g = h$.)
3. D (The three angles in the figure form a right angle, and the angle that measures g degrees is vertical to one of those angles, which means $2h + g = 90$.)
4. E (The angles all form a straight angle, which is why $g + h + 48 = 180$.)
5. C (The three angles form a straight line and the angle in between the angle measuring 35° and the angle measuring h degrees is a vertical angle with the angle measuring g degrees, which means $g + h + 35 = 180$.)

Are You Ready for More?

1. What is the angle between the hour and minute hands of a clock at 3:00?

2. You might think that the angle between the hour and minute hands at 2:20 is 60 degrees, but it is not! The hour hand has moved beyond the 2. Calculate the angle between the clock hands at 2:20.
3. Find a time where the hour and minute hand are 40 degrees apart. (Assume that the time has a whole number of minutes.) Is there just one answer?

Student Response

1. 90 degrees
2. 50 degrees. At 2:20, the hour hand should be one-third of the way between the 2 and the 3. Since the angle between the 2 and the 3 is a 30-degree angle, the hour hand has moved 10 degrees toward the 3. Therefore, the angle is 50 degrees rather than 60.
3. 5:20 and 6:40. These can be found by guess-and-check. It may help to realize that the hour hand of a clock moves at half a degree per minute, and the minute hand of a clock moves at 6 degrees per minute.

Activity Synthesis

The goal of this discussion is for students to articulate the angle relationships they noticed in each figure and equation. Display the figures for all to see. Select previously identified students to share their explanations for each figure. If not mentioned in students' explanations be sure that students see the vertical, supplementary, straight, and right angle relationships in the figures.

Lesson Synthesis

- If you know that angles a and b are vertical, what equation could you use to represent this angle relationship? ($a = b$)
- If you know that angles c and d are complementary, what equation could you use to represent this angle relationship? ($c + d = 90$)
- If you know that angles e and f are supplementary, what equation could you use to represent this angle relationship? ($e + f = 180$)

As the situations become more intricate, you can use equations to keep track of what you know so that you can revisit them when you learn more information.

4.4 Missing Circle Angles

Cool Down: 5 minutes

Addressing

- 7.G.B

Student Task Statement

AD , BE , and CF are all diameters of the circle. The measure of angle AOB is 40 degrees. The measure of angle DOF is 120 degrees.

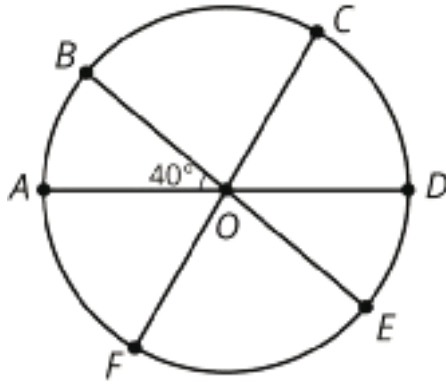

Find the measures of the angles:

1. BOC
2. COD

Student Response

1. Angle $BOC = 80^\circ$. Given angle $DOF = 120^\circ$, angle $AOC = 120^\circ$ because they are congruent vertical angles. Consequently, angles $AOB + BOC = 120^\circ$ because they are adjacent.
2. Angle $COD = 60^\circ$. Angle COD sums to 180° with angles DOF because the two are supplementary angles.

Student Lesson Summary

We can write equations that represent relationships between angles.

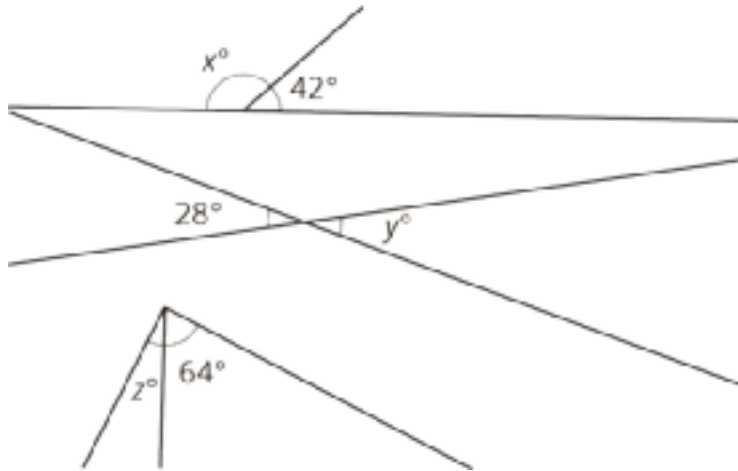

- The first pair of angles are supplementary, so $x + 42 = 180$.
- The second pair of angles are vertical angles, so $y = 28$.
- Assuming the third pair of angles form a right angle, they are complementary, so $z + 64 = 90$.

Lesson 4 Practice Problems

Problem 1

Statement

M is a point on line segment KL . NM is a line segment. Select **all** the equations that represent the relationship between the measures of the angles in the figure.

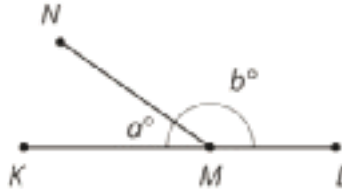

- A. $a = b$
- B. $a + b = 90$
- C. $b = 90 - a$
- D. $a + b = 180$
- E. $180 - a = b$
- F. $180 = b - a$

Solution

["D", "E"]

Problem 2

Statement

Which equation represents the relationship between the angles in the figure?

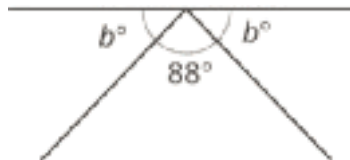

- A. $88 + b = 90$
- B. $88 + b = 180$
- C. $2b + 88 = 90$
- D. $2b + 88 = 180$

Solution

D

Problem 3

Statement

Segments AB , EF , and CD intersect at point C , and angle ACD is a right angle. Find the value of g .

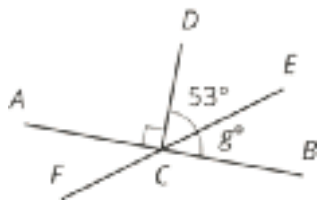

Solution

37

Problem 4

Statement

Select **all** the expressions that are the result of decreasing x by 80%.

- A. $\frac{20}{100}x$
- B. $x - \frac{80}{100}x$
- C. $\frac{100-20}{100}x$
- D. $0.80x$
- E. $(1 - 0.8)x$

Solution

["A", "B", "E"]

(From Unit 6, Lesson 12.)

Problem 5

Statement

Andre is solving the equation $4(x + \frac{3}{2}) = 7$. He says, "I can subtract $\frac{3}{2}$ from each side to get $4x = \frac{11}{2}$ and then divide by 4 to get $x = \frac{11}{8}$." Kiran says, "I think you made a mistake."

- a. How can Kiran know for sure that Andre's solution is incorrect?
- b. Describe Andre's error and explain how to correct his work.

Solution

Answers vary. Sample responses:

- a. He can substitute Andre's solution into the equation. If the solution is correct, the resulting equation will be true. $4(\frac{11}{8} + \frac{3}{2})$ is $11\frac{1}{2}$, not 7, so the solution is incorrect.
- b. Andre subtracted $\frac{3}{2}$ from each side, but that doesn't remove the $\frac{3}{2}$ from the equation because $\frac{3}{2}$ is part of an expression multiplied by 4. Andre could divide each side by 4 to get $x + \frac{3}{2} = \frac{7}{4}$ and then subtract $\frac{3}{2}$ on each side to get $x = \frac{1}{4}$. (Or, he could use the distributive property to write $4x + 6 = 7$, subtract 6 from each side to get $4x = 1$, and then divide by 4 on each side to get $x = \frac{1}{4}$.)

(From Unit 6, Lesson 8.)

Problem 6

Statement

Solve each equation.

$$\frac{1}{7}a + \frac{3}{4} = \frac{9}{8}$$

$$\frac{2}{3} + \frac{1}{5}b = \frac{5}{6}$$

$$\frac{3}{2} = \frac{4}{3}c + \frac{2}{3}$$

$$0.3d + 7.9 = 9.1$$

$$11.03 = 8.78 + 0.02e$$

Solution

- a. $a = \frac{21}{8}$
- b. $b = \frac{5}{6}$
- c. $c = \frac{5}{8}$
- d. $d = 4$
- e. $e = 112.5$

(From Unit 6, Lesson 7.)

Problem 7

Statement

A train travels at a constant speed for a long distance. Write the two constants of proportionality for the relationship between distance traveled and elapsed time. Explain what each of them means.

| time elapsed (hr) | distance (mi) |
|-------------------|---------------|
| 1.2 | 54 |
| 3 | 135 |
| 4 | 180 |

Solution

45. The train travels 45 miles in 1 hour

$\frac{1}{45}$. It takes $\frac{1}{45}$ hours for the train to travel 1 mile

(From Unit 2, Lesson 5.)

Lesson 5: Using Equations to Solve for Unknown Angles

Goals

- Critique whether a given equation represents the relationship between angles in a diagram.
- Solve an equation that represents a relationship between angle measures, and explain (in writing and using other representations) the reasoning.
- Write an equation of the form $px + q = r$ or $p(x + q) = r$ to represent the relationship between angles in a given diagram.

Learning Targets

- I can write an equation to represent a relationship between angle measures and solve the equation to find unknown angle measures.

Lesson Narrative

In the previous lesson, students saw that equations could be used to represent relationships between angles. In this lesson, students practice writing and solving equations of the form $px + q = r$ in the context of finding unknown angle measures. This brings together their work with equations from the previous unit and their work with angles from earlier lessons in this unit, giving students a chance to build fluency with both of these concepts.

Alignments

Building On

- 7.EE.B.4: Use variables to represent quantities in a real-world or mathematical problem, and construct simple equations and inequalities to solve problems by reasoning about the quantities.

Addressing

- 7.EE.B.4: Use variables to represent quantities in a real-world or mathematical problem, and construct simple equations and inequalities to solve problems by reasoning about the quantities.
- 7.G.B.5: Use facts about supplementary, complementary, vertical, and adjacent angles in a multi-step problem to write and solve simple equations for an unknown angle in a figure.

Instructional Routines

- MLR1: Stronger and Clearer Each Time
- MLR8: Discussion Supports
- Think Pair Share

Student Learning Goals

Let's figure out missing angles using equations.

5.1 Is This Enough?

Warm Up: 5 minutes

In this activity, students consider whether there is enough information given to solve for the unknown angle measures. In previous lessons, students were given the measures of some angles in a figure and asked to solve for another. In this warm-up, the figure contains two unknowns and students are asked to critique Tyler's thinking (MP3).

The discussion addresses the case in which angles a and b are equal to each other, in preparation for future activities in this lesson that have multiple unknown angles with the same measure. Monitor for students who agree and disagree with Tyler's thinking, and ask them to share during the discussion.

Building On

- 7.EE.B.4

Addressing

- 7.G.B.5

Instructional Routines

- Think Pair Share

Launch

Arrange students in groups of 2. Give students 1 minute of quiet think time followed by time to discuss their reasoning with their partner. Follow with a whole-class discussion.

Anticipated Misconceptions

Some students may want to use tools from their geometry toolkits to measure the angles. Explain that the question is asking if they can solve the problem by only looking at the figure, not by measuring it.

Student Task Statement

Tyler thinks that this figure has enough information to figure out the values of a and b .

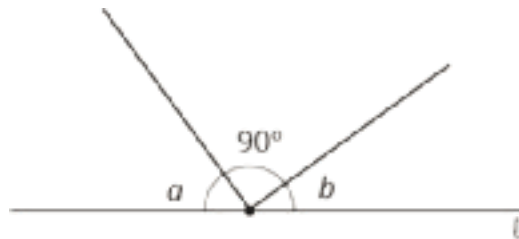

Do you agree? Explain your reasoning.

Student Response

I disagree with Tyler. Sample reasoning: We don't know how much bigger a is than b . All we know for sure is that $a + b = 90$.

Activity Synthesis

Poll the class on whether or not they agree with Tyler. Invite students to share their reasoning until they reach an agreement that Tyler is incorrect.

Ask students to come up with an equation to represent the angle measures in the figure. ($a + 90 + b = 180$ or equivalent) Record their answers for all to see.

Display this image. Invite students to share how this figure is the same as the figure from the task and how it is different.

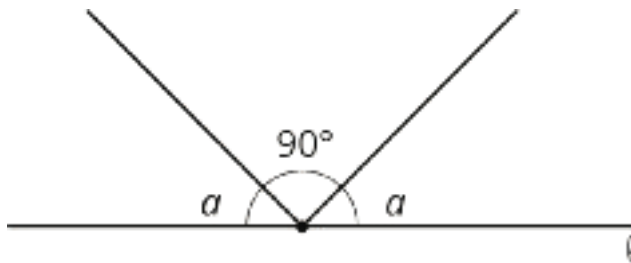

If students do not mention any of these points, make sure to point them out:

- Some things that are the same are the fact that there are still two angles with unknown measures and the measures of the three angles sum to 180 degrees. The two unknown angles are still complementary.
- The main difference is that the two unknown angles have the same measure.
- This figure can be represented with the equation $a + 90 + a = 180$ or equivalent.
- Because both unknown angles have the same measure, we have enough information to know the value of a .
- $a = 45$

5.2 What Does It Look Like?

15 minutes

The purpose of this activity is for students to practice solving equations that represent relationships between angles, in preparation for the next activity where students will write such equations themselves.

The last three figures include right angles, but they are not marked (except that the task statement says to assume angles that look like right angles are right angles). This may come up in discussion after students have had time to work.

Addressing

- 7.EE.B.4
- 7.G.B.5

Instructional Routines

- MLR1: Stronger and Clearer Each Time
- Think Pair Share

Launch

Tell students that each diagram has two possible equations, and their job is to choose the equation that best represents a relationship between angles in the diagram. Then, solve their chosen equation.

Keep students in the same groups. Give 5 minutes of quiet work time followed by time to discuss reasoning with a partner. Follow with a whole-class discussion.

Access for Students with Disabilities

Representation: Internalize Comprehension. Activate or supply background knowledge by asking students to start by labeling any angles they can find with their degree measure. Allow students to use calculators to ensure inclusive participation in the activity.

Supports accessibility for: Memory; Conceptual processing

Anticipated Misconceptions

If students struggle working with equations, encourage them to start with the diagram and label any angles they can figure out with their degree measure. The thinking necessary to figure out the measures of other angles may help them recognize a corresponding equation. Prompt students to recall what it looks like when an angle measures 90 degrees and what it looks like when an angle measures 180 degrees.

Student Task Statement

Elena and Diego each wrote equations to represent these diagrams. For each diagram, decide which equation you agree with, and solve it. You can assume that angles that look like right angles are indeed right angles.

1. Elena: $x = 35$

Diego: $x + 35 = 180$

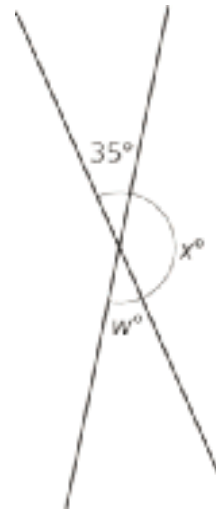

2. Elena: $35 + w + 41 = 180$

Diego: $w + 35 = 180$

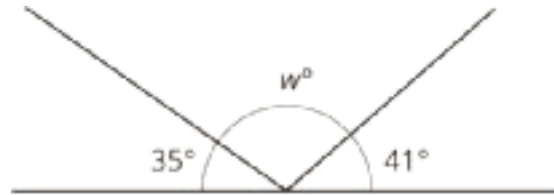

3. Elena: $w + 35 = 90$

Diego: $2w + 35 = 90$

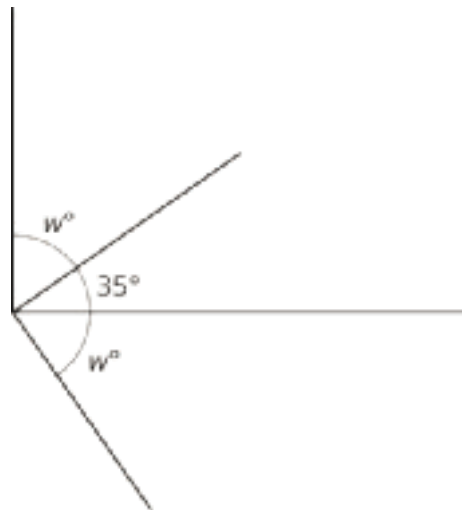

4. Elena: $2w + 35 = 90$

Diego: $w + 35 = 90$

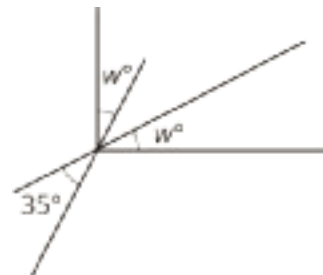

5. Elena: $w + 148 = 180$

Diego: $x + 90 = 148$

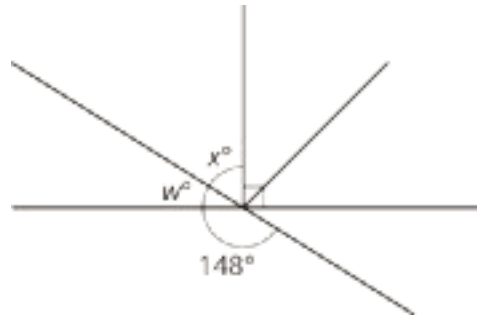

Student Response

1. Diego's equation: $x + 35 = 180$. Solution: 145.
2. Elena's equation: $35 + w + 41 = 180$. Solution: 104.
3. Elena's equation: $w + 35 = 90$. Solution: 55.
4. Elena's equation: $2w + 35 = 90$. Solution: 27.5.
5. Both equations. $w = 32$ and $x = 58$.

Activity Synthesis

Select students to share equations they agreed with and angle measures they found for each problem. As students share their explanations consider asking these questions:

- "Where do you see the relationship expressed in the equation in the given figure? (and vice versa)"
- "Did you and your partner agree on the equations and angle measures?"

For the last question, have students who used different equations to figure out the unknown angle measures share their explanations. Ask students:

- "What angle relationship did you need to recognize to use Elena's equation?" (That the angle with a measure of w degrees and the angle measuring 148 degrees were supplementary.)
- "What angle relationship did you need to recognize to use Diego's equation?" (That the angle measuring 148 degrees formed a vertical angle with the right angle and the angle measuring x degrees.)
- "Does either method get us the same answer for both unknown angle measures?" (Yes.)

Explain to students that there might be multiple ways to get an answer because of the many angle relationships found in some figures. Encourage them to look for different methods in the next activity.

Access for English Language Learners

Speaking: MLR1 Stronger and Clearer Each Time. Use this routine to provide students with a structured opportunity to refine their explanations about whether or not they agree with Tyler. Give students time to meet with 2–3 partners, to share and get feedback on their responses. Provide prompts for feedback that will help students strengthen their ideas and clarify their language (e.g., “Can you give an example?”, “Why do you think...?”, “Can you say that another way?”, etc.). Give students 1–2 minutes to revise their writing based on the feedback they received.

Design Principle(s): Optimize output (for explanation)

5.3 Calculate the Measure

10 minutes

This activity is a culmination of all the work students have done with angles in this unit. With less support than in previous activities, students come up with equations that represent the relationships between angles in a figure. Then, students solve their equation to find each unknown angle measure.

Addressing

- 7.EE.B.4
- 7.G.B.5

Instructional Routines

- MLR8: Discussion Supports

Launch

Encourage students to write an equation for each problem. Give students 2–3 minutes of quiet work time followed by a whole-class discussion.

Representation: Internalize Comprehension. Activate or supply background knowledge by asking students to start by looking for any vertical, complementary and supplementary angles. Allow students to use calculators to ensure inclusive participation in the activity.

Supports accessibility for: Memory; Conceptual processing

Anticipated Misconceptions

If students struggle to see the angle relationships in the figures, prompt them to look for any angles that are vertical, complementary, or supplementary to get them started.

Student Task Statement

Find the unknown angle measures. Show your thinking. Organize it so it can be followed by others.

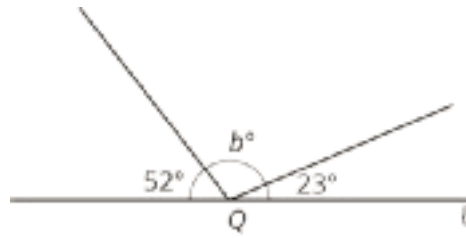
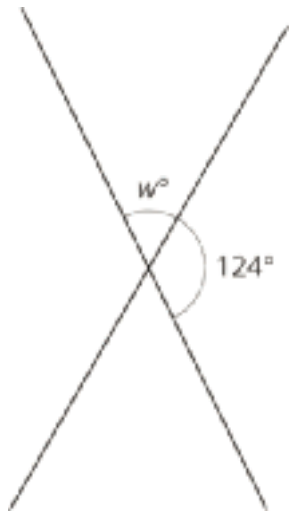

Lines l and m are perpendicular.

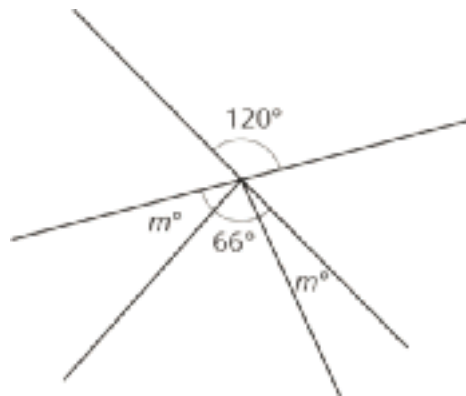
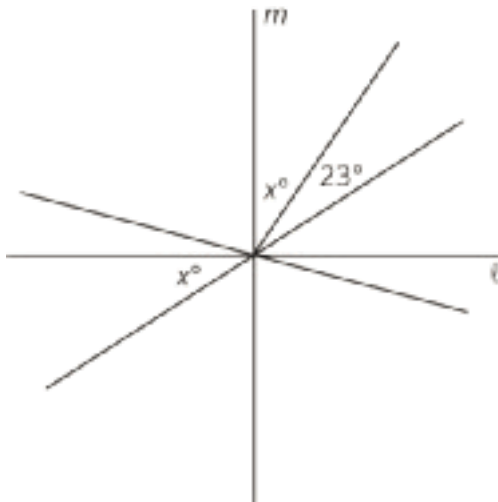

Student Response

- $w = 56$. Sample reasoning: $2(w + 124) = 360$, $w + 124 = 180$, $w = 180 - 124$
- $b = 105$. Sample reasoning: $b + 52 + 23 = 180$, $b = 180 - (52 + 23)$
- $x = 33.5$ or equivalent. Sample reasoning: $2x + 23 = 90$, $2x = 90 - 23$, $x = \frac{1}{2}(90 - 23)$
- $m = 27$. Sample reasoning: $2m + 66 = 120$, $2m = 120 - 66$, $m = \frac{1}{2}(120 - 66)$

Are You Ready for More?

The diagram contains three squares. Three additional segments have been drawn that connect corners of the squares. We want to find the exact value of $a + b + c$.

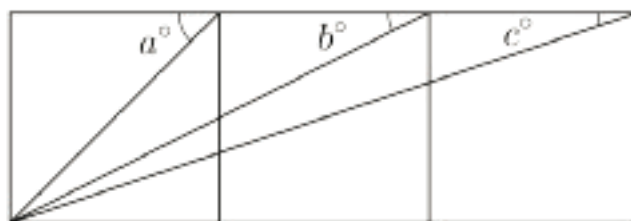

1. Use a protractor to measure the three angles. Use your measurements to conjecture about the value of $a + b + c$.
2. Find the exact value of $a + b + c$ by reasoning about the diagram.

Student Response

$a + b + c = 90$. Measuring carefully with a protractor is convincing, but there are many ways to show that $a + b + c$ is exactly 90° . One way is to expand the diagram with more squares and draw some more segments. Look at the three adjacent angles with vertices at point K . The measure of angle GKH must equal b because segment KG spans two squares in the same way CJ does. Just like angle ABC , angle CKG must measure 45° , since triangle CKG is a right triangle.

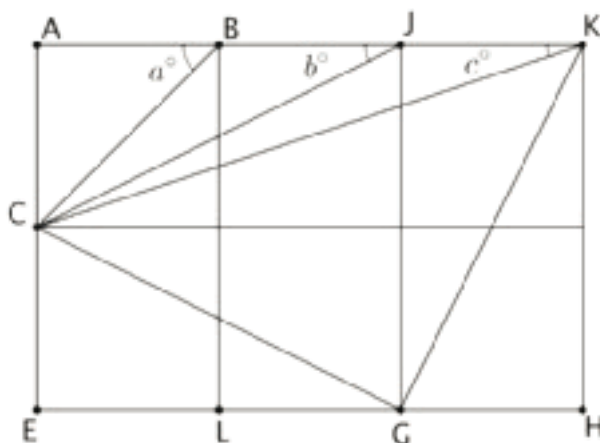

Activity Synthesis

The goal of this discussion is for students to see different equations that can be used to represent and solve for the same unknown angle measures.

Select students to share their answers to each problem. Consider asking some of the following questions:

- “Did anyone use a different equation for this same problem? If so, did you get the same answer?”
- “Were any of the questions harder than others? Why?”

- “Were there any questions you used a strategy that was new to you?”
-

Access for English Language Learners

Speaking: MLR8 Discussion Supports. When selected students share how they calculated the angle measurements, invite other students to challenge an idea, elaborate on an idea, or clarify the idea using improved mathematical language. Encourage students to demonstrate central concepts of the angle relationships (e.g., complementary, supplementary, vertical) multi-modally by explaining their reasoning using images of the angles as well as gestures. This will support student understanding about how to write equations that represent the relationships between angles in a figure.

Design Principle(s): Optimize output (for explanation); Support sense-making

Lesson Synthesis

- How can equations help us solve for an unknown angle measure? (They allow us to represent relationships among angles. Then we can solve the equation to find the unknown angle measures.)
- Is there only one way to solve for an unknown angle measure? (No, there are usually a few different equations that can be used, based on the relationships present in the figure.)

5.4 In Words

Cool Down: 5 minutes

Addressing

- 7.EE.B.4
- 7.G.B.5

Student Task Statement

Here are three intersecting lines.

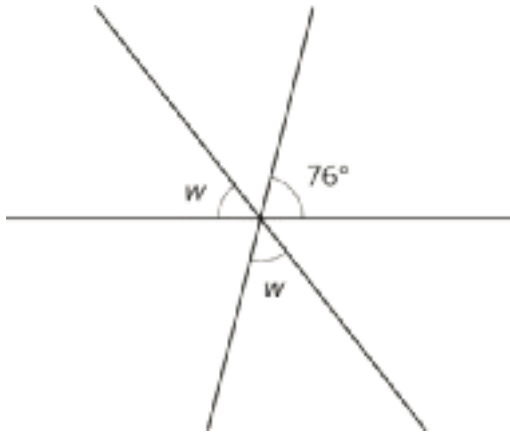

1. Write an equation that represents a relationship between these angles.
2. Describe, in words, the process you would use to find w .

Student Response

1. Answers vary. Samples responses: $2w + 76 = 180$ or $4w + 152 = 360$.
2. Answers vary. Sample responses:
 - Subtract 76 from 180 and then divide by 2 (or multiply by $\frac{1}{2}$).
 - Subtract 152 from 360 and then divide by 4 (or multiply by $\frac{1}{4}$).

Student Lesson Summary

To find an unknown angle measure, sometimes it is helpful to write and solve an equation that represents the situation. For example, suppose we want to know the value of x in this diagram.

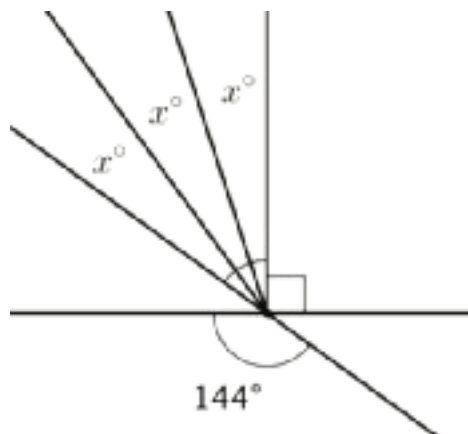

Using what we know about vertical angles, we can write the equation $3x + 90 = 144$ to represent this situation. Then we can solve the equation.

$$\begin{aligned}
 3x + 90 &= 144 \\
 3x + 90 - 90 &= 144 - 90 \\
 3x &= 54 \\
 3x \cdot \frac{1}{3} &= 54 \cdot \frac{1}{3} \\
 x &= 18
 \end{aligned}$$

Lesson 5 Practice Problems

Problem 1

Statement

Segments AB , DC , and EC intersect at point C . Angle DCE measures 148° . Find the value of x .

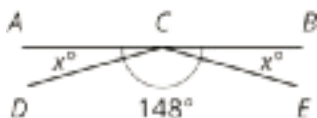

Solution

16

Problem 2

Statement

Line ℓ is perpendicular to line m . Find the value of x and w .

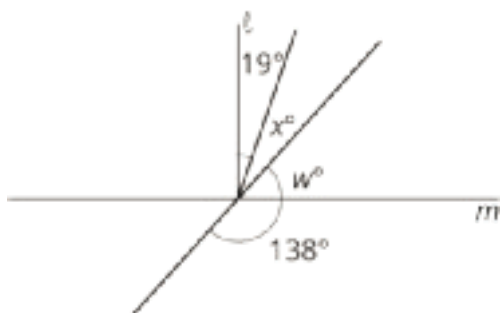

Solution

$x = 29$ and $w = 42$

Problem 3

Statement

If you knew that two angles were complementary and were given the measure of one of those angles, would you be able to find the measure of the other angle? Explain your reasoning.

Solution

Yes, because one angle would be known and if two angles are complementary, then the measures of the two angles sum to 90° .

Problem 4

Statement

For each inequality, decide whether the solution is represented by $x < 4.5$ or $x > 4.5$.

a. $-24 > -6(x - 0.5)$

b. $-8x + 6 > -30$

c. $-2(x + 3.2) < -15.4$

Solution

a. $x > 4.5$

b. $x < 4.5$

c. $x > 4.5$

(From Unit 6, Lesson 15.)

Problem 5

Statement

A runner ran $\frac{2}{3}$ of a 5 kilometer race in 21 minutes. They ran the entire race at a constant speed.

a. How long did it take to run the entire race?

b. How many minutes did it take to run 1 kilometer?

Solution

a. 31.5 minutes

b. 6.3 minutes

One way to find the answers to both questions is using a ratio table:

| distance (km) | time (min) |
|----------------|------------|
| $\frac{10}{3}$ | 21 |
| 10 | 63 |
| 5 | 31.5 |
| 1 | 6.3 |

(From Unit 4, Lesson 2.)

Problem 6

Statement

Jada, Elena, and Lin walked a total of 37 miles last week. Jada walked 4 more miles than Elena, and Lin walked 2 more miles than Jada. The diagram represents this situation:

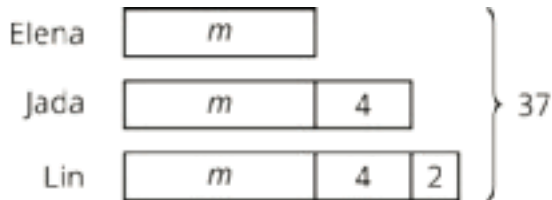

Find the number of miles that they each walked. Explain or show your reasoning.

Solution

Elena: 9 miles, Jada: 13 miles, Lin: 15 miles

Possible strategies:

- $3m + 10 = 37$, $m = 9$
- Start with the total of 37 miles, subtract 10, and divide by 3

(From Unit 6, Lesson 12.)

Problem 7

Statement

Select **all** the expressions that are equivalent to $-36x + 54y - 90$.

- A. $-9(4x - 6y - 10)$
- B. $-18(2x - 3y + 5)$
- C. $-6(6x + 9y - 15)$
- D. $18(-2x + 3y - 5)$
- E. $-2(18x - 27y + 45)$
- F. $2(-18x + 54y - 90)$

Solution

["B", "D", "E"]

(From Unit 6, Lesson 19.)

Section: Drawing Polygons with Given Conditions

Lesson 6: Building Polygons (Part 1)

Goals

- Comprehend that two shapes are considered “identical copies” if they can be placed on top of each other and match up exactly.
- Recognize that four side lengths do not determine a unique quadrilateral, but that three side lengths can determine a unique triangle.
- Use manipulatives to create a polygon with given side lengths, and describe (orally) the resulting shape.

Learning Targets

- I can show that the 3 side lengths that form a triangle cannot be rearranged to form a different triangle.
- I can show that the 4 side lengths that form a quadrilateral can be rearranged to form different quadrilaterals.

Lesson Narrative

This lesson is the first in a series of lessons in which students create shapes with given conditions. During these lessons students think about what conditions are needed to determine a unique figure, in preparation for future work with congruence in grade 8 and high school. These lessons continue the language used in grade 6: two polygons are identical if they match up exactly when placed one on top of the other.

In this lesson, students experiment with making polygons of various numbers and combinations of side lengths, using cardboard strips and metal fasteners. The goal of the lesson is to help students see that sometimes lots of different shapes are possible under given constraints about side lengths, and that at other times, with different constraints, it might be that only one shape is possible or that no shape is possible. In this lesson, students do not try to formulate general rules about what side lengths are possible; in the next lesson, they formulate such a rule for triangles.

Alignments

Addressing

- 7.G.A.2: Draw (freehand, with ruler and protractor, and with technology) geometric shapes with given conditions. Focus on constructing triangles from three measures of angles or sides, noticing when the conditions determine a unique triangle, more than one triangle, or no triangle.

- 7.NS.A.1: Apply and extend previous understandings of addition and subtraction to add and subtract rational numbers; represent addition and subtraction on a horizontal or vertical number line diagram.

Instructional Routines

- MLR7: Compare and Connect
- MLR8: Discussion Supports
- True or False

Required Materials

Geometry toolkits

For grade 6: tracing paper, graph paper, colored pencils, scissors, and an index card to use as a straightedge or to mark right angles.

For grades 7 and 8: everything in grade 6, plus a ruler and protractor. Clear protractors with no holes and with radial lines printed on them are recommended.

Notes: (1) "Tracing paper" is easiest to use when it's a smaller size. Commercially-available "patty

paper" is 5 inches by 5 inches and ideal for this. If using larger sheets of tracing paper, consider cutting them down for student use. (2) When compasses are required in grades 6-8 they are listed as a separate Required Material.

Metal paper fasteners

brass brads

Pre-printed slips, cut from copies of the Instructional master

Required Preparation

For the activities in this lesson and the next, you will need slips cut from copies of the What Can You Build? Instructional master. Prepare 1 copy for every 2 students. These slips can be reused from one class to the next. To make the slips sturdier, it is recommended to copy them onto card stock. If card stock is not available, consider gluing each copy to light cardboard, such as a cereal box. Also if possible, copy each set of slips on a different color of paper, so that a stray strip can quickly be put back.

After the slips are cut, punch holes into the endpoints of each segment. A standard hole punch makes holes that are a little larger than needed for the metal paper fasteners, causing the cardboard strips to wiggle around. If possible, find a way to punch holes that are slightly smaller than the size of a standard hole punch.

Put each set of strips in an envelope. Prepare to distribute at least 12 metal paper fasteners (i.e., brass brads) to each group.

Note: If using the digital version of every activity, the strips and fasteners will not be needed.

Student Learning Goals

Let's build shapes.

6.1 True or False: Signed Numbers

Warm Up: 5 minutes

The purpose of this warm-up is to encourage students to reason about properties of operations without evaluating each expression. Encourage students to think about the meaning of the operations in each question.

Addressing

- 7.NS.A.1

Instructional Routines

- MLR7: Compare and Connect
- True or False

Launch

Display each problem one at a time. Tell students to give a signal when they have a response. Give 30 seconds of quiet think time. Ask students to share their reasoning for each. Record and display their thinking for all to see. Leave each problem displayed as you move onto the next problem.

Representation: Internalize Comprehension. To support working memory, provide students with sticky notes or mini whiteboards.

Supports accessibility for: Memory; Organization

Anticipated Misconceptions

Some students may try evaluating each side of each equation. Encourage them to look for patterns or shortcuts that would help them answer each question without doing all the calculations.

Student Task Statement

Decide whether each equation is true or false. Be prepared to explain your reasoning.

$$4 \cdot (-6) = (-6) + (-6) + (-6) + (-6)$$

$$-8 \cdot 4 = (-8 \cdot 3) + 4$$

$$6 \cdot (-7) = 7 \cdot (-7) + 7$$

$$-10 - 6 = -10 - (-6)$$

Student Response

1. True. Four groups of -6 added together can be thought of as 4 times -6.
2. False. $-8 \cdot 4 = (-8 \cdot 3) - 8$ or $-8 \cdot 4 = (-8 \cdot 3) + (-8)$

3. True. 7 is the additive inverse of -7, so adding 7 at the end makes up for the one additional group of -7 in the multiplication.
4. False. $-10 - 6 = -10 - (+6)$ or $-10 - 6 = -10 + (-6)$

Activity Synthesis

Ask students to share their reasoning. Record and display the responses for all to see. To involve more students in the conversation, use some of the following questions:

- “Do you agree or disagree? Why?”
- “Who can restate ___’s reasoning in a different way?”
- “Did anyone reason about the problem the same way, but would explain it differently?”
- “Did anyone reason about the problem in a different way?”
- “Does anyone want to add on to ____’s reasoning?” If there is time, ask students how they could rewrite the false equations to be true.

See MLR 7 (Connect and Compare) for more examples.

6.2 What Can You Build?

15 minutes (there is a digital version of this activity)

The purpose of this activity is for students to explore a physical representation of polygons and make observations about triangles and quadrilaterals. This introductory activity serves to familiarize students with the tools and definitions they will use in future activities. Students may notice that some sets of 3 strips cannot make a triangle, but formalizing rules about what lengths can and cannot be used to form a triangle is *not* the goal of this lesson.

This is the place to notice that pairs of triangles with 3 matching lengths make identical triangles, whereas pairs of quadrilaterals with 4 matching lengths do not necessarily make identical quadrilaterals. Students will express this observation more formally in the next activity.

As students work, select at least one group’s triangle and another group’s quadrilateral to recreate for the whole-class discussion.

Addressing

- 7.G.A.2

Instructional Routines

- MLR8: Discussion Supports

Launch

Arrange students in groups of 2. Remind students that a polygon is a closed shape with straight sides. If necessary, demonstrate how to use the fasteners to connect the strips.

Distribute one set of strips and fasteners to each group. Provide access to geometry toolkit, including rulers and protractors. Give students 5–6 minutes of quiet work time followed by a whole-class discussion.

For classes using the digital materials, there is an applet for students to use to build polygons with the given side lengths. If necessary, demonstrate how to create a vertex by overlapping the endpoints of two segments. It may work best for positioning each segment to put the green endpoint in place first and then adjust the yellow endpoint as desired.

Access for Students with Disabilities

Representation: Internalize Comprehension. Begin the activity with concrete or familiar contexts. Remind students that a polygon is a closed figure with straight sides. Demonstrate how to use fasteners to connect the slips.

Supports accessibility for: Conceptual processing; Memory

Anticipated Misconceptions

Some students may try to bend the strips to make shapes with curved sides. Remind them that a polygon has all straight sides.

Student Task Statement

Your teacher will give you some strips of different lengths and fasteners you can use to attach the corners.

1. Use the pieces to build several polygons, including at least one triangle and one quadrilateral.
2. After you finish building several polygons, select one triangle and one quadrilateral that you have made.
 - a. Measure all the angles in the two shapes you selected.
 - b. Using these measurements along with the side lengths as marked, draw your triangle and quadrilateral as accurately as possible.

Student Response

Answers vary.

Activity Synthesis

The purpose of this discussion is to establish what is meant when we say two shapes are identical copies. While students don't use the word *congruent* until grade 8, they should recognize that two shapes are identical only when they can match perfectly on top of each other by movements that don't change lengths or angles.

Invite a group to share the side lengths they chose for their triangle. Create a copy of the triangle with another set of strips and fasteners. Display it for all to see alongside the group's original triangle, but oriented differently. Ask students, "Are the two shapes identical? How can you tell?" (Yes, because you can put them on top of each other and they match up exactly.) Demonstrate turning or flipping the triangle, as needed, to place one copy on top of the other and show that they match.

Repeat the demonstration with a group's quadrilateral. Create a copy that has the same side lengths as what they used, but different angles. Demonstrate the "floppiness" of the quadrilateral (that is, the angles can change even though the side lengths remain the same). Make sure students realize that the two quadrilaterals are not necessarily identical copies, even though they have the same side lengths.

Access for English Language Learners

Speaking, Listening: MLR8 Discussion Supports. Use this routine to support whole-class discussion. After a group shares the side lengths they chose for their triangle, ask students to restate or revoice what they heard using mathematical language. Consider providing students time to restate what they heard to a partner, before selecting one or two students to share with the class. Ask the original group if their peer was accurately able to restate their thinking. Encourage students to supplement their explanations multi-modally by using gestures with the polygons.

Design Principle(s): Support sense-making; Maximize meta-awareness

6.3 Building Diego's and Jada's Shapes

10 minutes (there is a digital version of this activity)

The purpose of this activity is to reinforce that some conditions define a unique polygon while others do not. Students build polygons given only a description of their side lengths. They articulate that this is not enough information to guarantee that a pair of quadrilaterals are identical copies. On the other hand, triangles have a special property that three specific side lengths result in a unique triangle. Students should notice that their recreation of Jada's triangle is rigid; the side lengths and angles are all fixed.

Monitor for students who try putting the side lengths together in different orders to build different polygons and invite them to share during the whole-class discussion.

Addressing

- 7.G.A.2

Instructional Routines

- MLR7: Compare and Connect

Launch

Keep students in the same groups. Tell them they will continue to use the strips and fasteners from the previous activity. Encourage students to think about whether there are different shapes that would fulfill the given conditions. Give students 5–6 minutes of group work time followed by a whole-class discussion.

If using the digital version, students can keep using the same applet that they explored in the previous activity to build shapes with the given conditions.

Anticipated Misconceptions

Students may think that their triangle is different from Jada's because hers is "upside down." Ask the student to turn their triangle around and ask them if it is now a different triangle. While there is a good debate to be had if they continue to insist they are different, let the students know that, for this unit, we will consider shapes that have been turned or flipped or moved as identical copies and thus "not different."

Student Task Statement

1. Diego built a quadrilateral using side lengths of 4 in, 5 in, 6 in, and 9 in.
 - a. Build such a shape.
 - b. Is your shape an identical copy of Diego's shape? Explain your reasoning.
2. Jada built a triangle using side lengths of 4 in, 5 in, and 8 in.
 - a. Build such a shape.
 - b. Is your shape an identical copy of Jada's shape? Explain your reasoning.

Student Response

1. No, my quadrilateral is probably not an identical copy of Diego's quadrilateral, because it is floppy; there are lots of different angles I can use to make a quadrilateral with these side lengths.
2. Yes, my triangle should be an identical copy of Jada's triangle, because it is not floppy; there is no way to change the angles to make a different triangle with these side lengths.

Activity Synthesis

Select previously identified students to share their constructions and explanations. Display each student's example for all to see.

If desired, reveal Diego and Jada's shapes and display for all to see along side students' work.

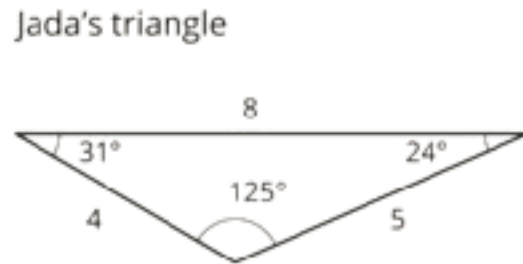
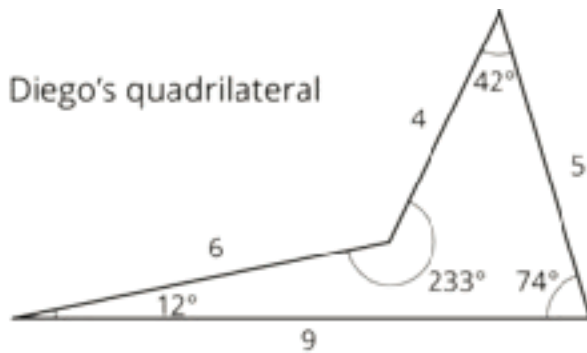

Ask students:

- "Is this what you thought Jada and Diego's shapes looked like?"
- "Which shape did you make an identical copy of?" (Jada's triangle.)
- "Why did you not make an identical copy of Diego's shape?" (Because you can make quadrilaterals with the same side lengths but different angle measure.)

Consider explaining to students how this finding is applied in construction projects. For stability, the internal structures of many buildings (and bridges) will include triangles. Rectangles or other polygons with more than three sides often include triangular supports on the inside, to make the construction more rigid and less floppy.

Access for English Language Learners

Speaking: MLR7 Compare and Connect. Use this routine to support whole-class discussion. Ask students to consider what is the same and what is different about their quadrilateral as compared to Diego's. Draw students' attention to the association between the order of side lengths in each quadrilateral and the angle measures in each shape. In this discussion, demonstrate the language used to make sense of the conditions required to make identical figures. Talking about and comparing the quadrilaterals will help draw students' attention to the conditions that define a unique polygon.

Design Principle(s): Maximize meta-awareness

6.4 Building Han's Shape

Optional: 5 minutes (there is a digital version of this activity)

The purpose of this activity is for students to see that sometimes it is impossible to build a polygon with certain conditions, but also that they need to think carefully about the information they are given before making assumptions.

In this case, students are given 3 side lengths that cannot form a triangle and are told to build a polygon. Students may assume that because they were given 3 side lengths, their shape is

supposed to be a triangle; however, they will only succeed in building a polygon using the specified side lengths if it has more than 3 sides. Formalizing rules about what lengths can and cannot be used to form a triangle is *not* the goal of this activity.

As students work on the task, monitor for students who realize that the shape cannot be a triangle and for students who realize it can be a polygon with more than 3 sides.

Addressing

- 7.G.A.2

Launch

Keep students in the same groups. Students keep using the strips and fasteners from the previous activity. Encourage students to read the question carefully. Give students 3–4 minutes of group work time, followed by a whole-class discussion.

If using the digital lesson, the applet is the same as the previous activities.

Anticipated Misconceptions

Students may say that there is no way Han could have built this shape, because they are assuming it must be a triangle. Ask students if the question specifies that the shape is a triangle. If needed, remind students of the definition of *polygon* and prompt them to consider what they could do to finish building a closed shape with all straight sides.

Student Task Statement

Han built a polygon using side lengths of 3 in, 4 in, and 9 in.

1. Build such a shape.
2. What do you notice?

Student Response

Answers vary. Sample response: I notice that this shape cannot be a triangle. I had to include a fourth side to make a quadrilateral.

Activity Synthesis

Select previously identified students to share their explanations. Make sure students realize that this shape cannot be built as a triangle; however, it is possible to build a polygon with more than 3 sides. Tell students, “As the unit progresses, you will be asked to create or draw shapes that include some conditions, but there may be some flexibility with the pieces that are not mentioned. Be aware of what must be included and what is not mentioned.”

If time permits, consider asking some of the following questions:

- “What length did you choose to use for your fourth side? Would another choice have worked?”

- “If another group used the same length for their fourth side as you, does their polygon have to be an identical copy of yours? How do you know?”
- “Did any group choose to have more than 4 sides on their polygon? Does such a shape fulfill the given conditions?”

Lesson Synthesis

- What kinds of shapes could you build with side lengths 4 inches, 4 inches, and 4 inches? (triangle, square, another quadrilateral, pentagon, etc.)
- What kinds of shapes could you **not** build with this set of side lengths and fasteners? (circle, oval, a 9 inch square, etc.)
- How is building a triangle with three given side lengths different from building a quadrilateral with four given side lengths? (the triangle must be a specific one, but the quadrilateral might be a lot of different things by changing the angles)

6.5 An Equilateral Quadrilateral

Cool Down: 5 minutes

Addressing

- 7.G.A.2

Student Task Statement

When asked to draw a quadrilateral with all four sides measuring 5 cm, Jada drew a square.

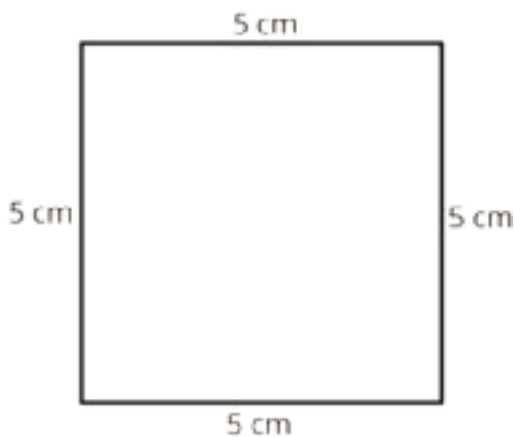

1. Do you agree with Jada’s answer?
2. Is there a different shape Jada could have drawn that would answer the question? Explain your reasoning.

Student Response

1. Yes, Jada’s shape has 4 sides, all measuring 5 cm.
2. A rhombus could be made with all four sides the same length, but without right angles.

Student Lesson Summary

Sometimes we are given a polygon and asked to find the lengths of the sides. What options do you have if you need to build a polygon with some side lengths? Sometimes, we can make lots of different figures. For example, if you have side lengths 5, 7, 11, and 14, here are some of the many, many quadrilaterals we can make with those side lengths:

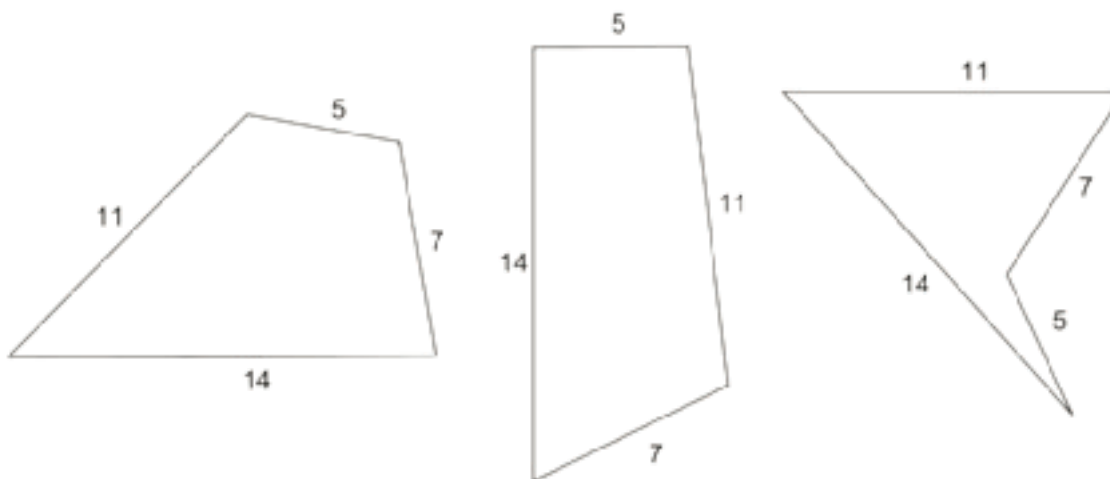

Sometimes, it is not possible to make a figure with certain side lengths. For example, 18, 1, 1, 1 (try it!).

We will continue to investigate the figures that can be made with given measures.

Lesson 6 Practice Problems

Problem 1

Statement

A rectangle has side lengths of 6 units and 3 units. Could you make a quadrilateral that is not identical using the same four side lengths? If so, describe it.

Solution

Yes, you could make a parallelogram or a kite using the side lengths 3, 3, 6, and 6.

Problem 2

Statement

Come up with an example of three side lengths that can not possibly make a triangle, and explain how you know.

Solution

Answers vary. Sample response: the lengths 1 foot, 1 inch, and 1 inch can not possibly make a triangle, because if you attach the 1 inch lengths to either end of the 1 foot length, the 1 inch lengths are too short to connect at their other ends.

Problem 3

Statement

Find x , y , and z .



Solution

$$x = 64, y = 18, z = 98$$

(From Unit 7, Lesson 3.)

Problem 4

Statement

How many right angles need to be put together to make:

- a. 360 degrees?
- b. 180 degrees?
- c. 270 degrees?
- d. A straight angle?

Solution

- a. 4
- b. 2
- c. 3
- d. 2

(From Unit 7, Lesson 1.)

Problem 5

Statement

Solve each equation.

$$\frac{1}{7}(x + \frac{3}{4}) = \frac{1}{8}$$

$$1.5 = 0.6(w + 0.4)$$

$$\frac{9}{2} = \frac{3}{4}(z + \frac{2}{3})$$

$$0.08(7.97 + v) = 0.832$$

Solution

- a. $\frac{1}{8}$
- b. $\frac{16}{3}$
- c. 2.1
- d. 2.43

(From Unit 6, Lesson 8.)

Problem 6

Statement

- a. You can buy 4 bottles of water from a vending machine for \$7. At this rate, how many bottles of water can you buy for \$28? If you get stuck, consider creating a table.
- b. It costs \$20 to buy 5 sandwiches from a vending machine. At this rate, what is the cost for 8 sandwiches? If you get stuck, consider creating a table.

Solution

a. 16

b. \$32

(From Unit 4, Lesson 3.)

Lesson 7: Building Polygons (Part 2)

Goals

- Explain (in writing) how to use circles to locate the point where the sides of a triangle with known side lengths should meet.
- Use manipulatives to justify when it is not possible to make a triangle with three given side lengths.
- Use manipulatives to show that there is a minimum and maximum length the third side of a triangle could be, given the other two side lengths.

Learning Targets

- I can reason about a figure with an unknown angle.
- I can show whether or not 3 side lengths will make a triangle.

Lesson Narrative

In this lesson, students experiment with constructing triangles given 2 or 3 side lengths. They start by working with cardboard strips and metal fasteners, as in the previous lesson. They discover that there are some combinations of lengths that do not make a triangle. Then students move toward using a ruler and compass, seeing that it recreates the functionality of the cardboard strips and metal fasteners more efficiently. The purpose of this transition is to help students move toward a mental understanding that does not depend on physical objects, helping them work toward the understanding that in a triangle the sum of any two sides must be greater than the other side.

When students use repeated reasoning with specific cases to formulate a general rule about which side lengths are possible for triangles, they engage in MP8.

Alignments

Addressing

- 7.G.A.2: Draw (freehand, with ruler and protractor, and with technology) geometric shapes with given conditions. Focus on constructing triangles from three measures of angles or sides, noticing when the conditions determine a unique triangle, more than one triangle, or no triangle.

Instructional Routines

- MLR7: Compare and Connect
- MLR8: Discussion Supports
- Think Pair Share

Required Materials

Compasses

Copies of Instructional master

Geometry toolkits

For grade 6: tracing paper, graph paper, colored pencils, scissors, and an index card to use as a straightedge or to mark right angles.

For grades 7 and 8: everything in grade 6, plus a ruler and protractor. Clear protractors with no holes and with radial lines printed on them are recommended.

Notes: (1) "Tracing paper" is easiest to use when it's a smaller size. Commercially-available "patty paper" is 5 inches by 5 inches and ideal for this. If using larger sheets of tracing paper, consider cutting them down for student use. (2) When compasses are required in grades 6-8 they are listed as a separate Required Material.

Metal paper fasteners

brass brads

Required Preparation

Print the Swinging the Sides Around Instructional master. Prepare 1 copy for every 2 students.

Students will also need the cardboard strips and metal paper fasteners from the previous lesson, as well as access to geometry toolkits and compasses.

Note: If using the digital version of every activity, these supplies will not be needed.

Student Learning Goals

Let's build more triangles.

7.1 Where Is Lin?

Warm Up: 5 minutes (there is a digital version of this activity)

The purpose of this warm-up is to remind students that when you have a fixed starting point, all the possible endpoints for a segment of a given length form a circle (centered around the starting point). The context of finding Lin's position in the playground helps make the geometric relationships more concrete for students. Since there are many possible distances between Lin and the swings (but not infinitely many), this activity serves as an introduction to formalizing rules about what lengths can and cannot be used to form a triangle.

Monitor for students who come up with different locations for Lin, as well as students who recognize that there are many possible locations, to share during the whole-class discussion.

Addressing

- 7.G.A.2

Instructional Routines

- Think Pair Share

Launch

Arrange students in groups of 2. If necessary, remind students of the directions north, south, east, and west and their relative position on a map. Provide access to geometry toolkits. Give students 2 minutes of quiet work time, followed by a partner and whole-class discussion.

Students with access to the digital materials can explore the applet.

Access for Students with Disabilities

Representation: Develop Language and Symbols. Display or provide charts with symbols and meanings. Display a chart of a compass showing the directions north, south, east and west.

Supports accessibility for: Conceptual processing; Memory

Anticipated Misconceptions

Some students might assume that the swings, the slide, and Lin are all on a straight line, and that she must be 8 meters away. Ask these students if the problem tells us which direction Lin is from the slide.

Some students may confuse the type of compass discussed in the Launch and the type of compass discussed in the Activity Synthesis. Consider displaying a sample object or image of each of them and explain that the same name refers to two different tools.

Student Task Statement

At a park, the slide is 5 meters east of the swings. Lin is standing 3 meters away from the slide.

1. Draw a diagram of the situation including a place where Lin could be.
2. How far away from the swings is Lin in your diagram?
3. Where are some other places Lin could be?

Student Response

1. Answers vary. See diagram.

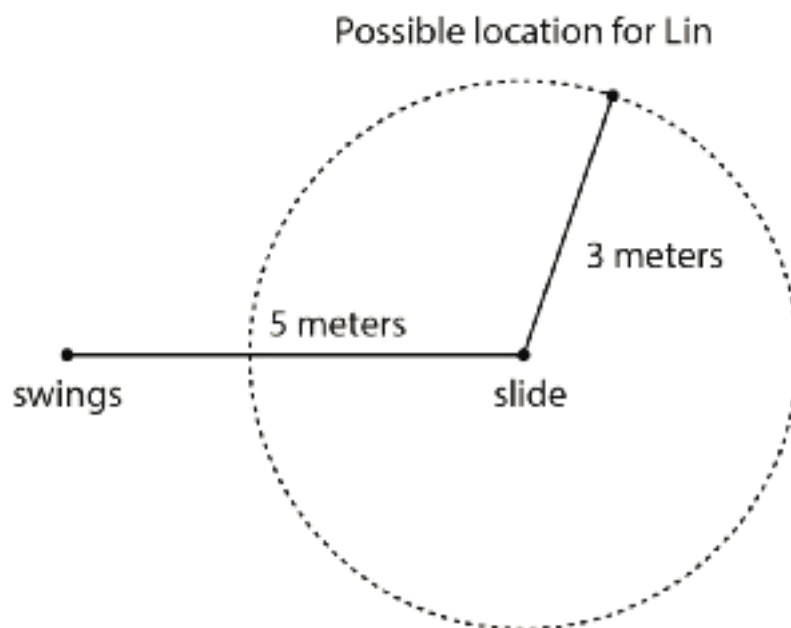

2. There is no way to know for sure, because we don't know what direction Lin is from the slide. She could be anywhere between 2 and 8 meters away from the swings.
3. Lin could be at any position along a circle that is centered on the slide and has a radius of 3 meters.

Activity Synthesis

First, have students compare answers and share their reasoning with a partner until they reach an agreement.

Next, ask selected students to share their diagrams of where Lin is located. Discuss the following questions with the whole class:

- "Do we know for sure where Lin is?" (No, because we don't know what direction she is from the swings.)
- "What shape is made by all the possible locations where Lin could be?" (a circle)
- "What is the closest Lin could be to the swings?" (2 m)
- "What is the farthest Lin could be away from the swings?" (8 m)

Consider using the applet at <https://ggbm.at/qkHk6Tpj> to show all the locations where Lin could be. Based on their work with drawing circles in a previous unit, some students may suggest that a compass could be used to draw all the possible locations where Lin could be. Consider having a student demonstrate how this could be done. If not mentioned by students, it is *not* necessary for the teacher to bring it up at this point.

7.2 How Long Is the Third Side?

15 minutes (there is a digital version of this activity)

The purpose of this activity is for students to experience that the sum of the lengths of the two shorter sides of a triangle must be greater than the length of the longest side. Students continue working with the cardboard strips and fasteners from the previous lesson to see how many different triangles they can build given two of the three side lengths. In the Activity Synthesis, the possible triangles are arranged in a way that helps students see the unknown angle between two known side lengths as a hinge. This prepares students for using compasses to draw triangles with given side lengths. They also continue to work at recognizing when two triangles are identical copies that are oriented differently.

As students work, monitor for those who:

- find different lengths for the third side of the triangle
- use precise language to describe how the two side lengths can move in relation to each other
- make a connection to the circle of Lin's possible positions from the previous activity

Addressing

- 7.G.A.2

Instructional Routines

- MLR8: Discussion Supports

Launch

Arrange students in groups of 4. Distribute *two* sets of strips and fasteners (from the previous lesson) to each group. Give students 7–10 minutes of group work time, followed by a whole-class discussion.

If using the digital lesson, students will be familiar with this applet from the previous lesson.

Anticipated Misconceptions

Some students may think that there are more than 5 possible triangles they can build, because they don't realize that some of the triangles they have listed are identical copies of other triangles on their list, with the side lengths written in a different order.

Some students may think that the third side of the triangle cannot be 4 or 5 inches, because then the triangle would have two sides of that length instead of the one asked for in the question. Explain that the triangle is acceptable as long as *at least* one side is 5 inches long and *at least* one side is 4 inches.

Some students may think that 8 is the longest the third side can be and 2 would be the shortest (if they were given a strip of that length), because they don't realize that there could be fractional side lengths.

Student Task Statement

Your teacher will give you some strips of different lengths and fasteners you can use to attach the corners.

1. Build as many different triangles as you can that have one side length of 5 inches and one of 4 inches. Record the side lengths of each triangle you build.
2. Are there any other lengths that could be used for the third side of the triangle but weren't in your set?
3. Are there any lengths that were in your set but could not be used as the third side of the triangle?

Student Response

1. There are 5 possible triangles, with the third side measuring 3 inches, 4 inches, 5 inches, 6 inches, or 8 inches.
2. Yes. The third side could be 2 inches, 7 inches, or any fractional length between 1 and 9 inches. Sample responses:

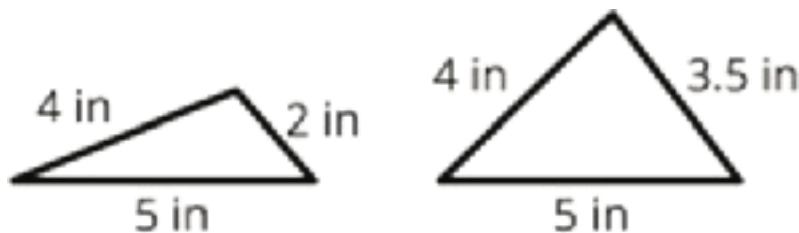

3. Yes. We could not use the 9 inch side to make a triangle, because it is a straight line when we connect it.

Are You Ready for More?

Assuming you had access to strips of any length, and you used the 9-inch and 5-inch strips as the first two sides, complete the sentences:

1. The third side can't be ____ inches or longer.
2. The third side can't be ____ inches or shorter.

Student Response

The longest the third side could be is shorter than 14 inches (such as 13 or 13.9).

The shortest the third side could be is longer than 4 inches (such as 5 or 4.1).

Activity Synthesis

Select previously identified groups to share a triangle they created. Establish whether each new triangle shared is the same as a triangle previously shared or is a different triangle. Collect one

example of each possible triangle and display them for all to see, in order of increasing side length for the third side. Continue until students agree all possible triangles are displayed.



To help students generalize about all the possible triangles that could be built with sides 4 inches and 5 inches, ask questions like the following:

- “What do you notice about the triangles?”
- “Why was it impossible to use the 9 inch side to create a triangle?”
- “What is the longest the third side of the triangle could be?” (more than 8, but less than 9, e.g., 8.5, 8.75, 8.9)
- “What is the shortest the third side of the triangle could be?” (less than 2, but more than 1, e.g., 1.5, 1.25, 1.1)
- “What happens when the third side is 1 inch or 9 inches?” (You get a straight line instead of a triangle.)

Display a 5 inch strip fastened to a 4 inch strip for all to see. Demonstrate rotating the 4-inch strip around 180° to line up with each of the displayed triangles, as well as to show the idea that the third side could have a fractional side length. Invite students to share how this relates to the previous activity about Lin’s distance from the swings. (If we hold one strip fixed, then all the possible locations where the other strip could end form a circle.)

Access for English Language Learners

Speaking: MLR8 Discussion Supports. Use this routine to support students as they generalize about the length of the third side of the triangle. Provide sentence frames such as: “The third side of a triangle will always be ___ because...” This will help students use mathematical language to generalize that the sum of the lengths of the two shorter sides of a triangle must be greater than the length of the longest side.

Design Principle(s): Optimize output (for generalization)

7.3 Swinging the Sides Around

15 minutes (there is a digital version of this activity)

The purpose of this activity is to relate the process for *building* a triangle given 3 side lengths (using cardboard strips and metal fasteners) to the process for *drawing* a triangle given 3 side lengths (using a compass). Students use the cardboard strips as an informal compass for drawing all the

possible locations where the given segments could end. They are reminded of their work with circles in a previous unit: that a circle is the set of all the points that are equally distant from a center point and that a compass is a useful tool, not just for drawing circles, but also for transferring lengths in general. This prepares them for using a compass to draw triangles in future lessons.

In this activity, students also consider what their drawing would look like if the two shorter sides were too short to make a triangle with the third given side length.

Left-handed students may find it easier to start with drawing the 3-inch circle on the left side of the 4-inch segment.

Addressing

- 7.G.A.2

Instructional Routines

- MLR7: Compare and Connect

Launch

Arrange students in groups of 2. Distribute one copy of the Instructional master to each group. Make sure each group has one complete set of strips and fasteners from the previous activity. Provide access to geometry toolkits and compasses.

Tell students to take one 4-inch piece and two 3-inch pieces and connect them so that the 4-inch piece is in between the 3-inch pieces as seen in the image. If necessary, display the image for all to see. Students should not connect the 3-inch pieces to each other.

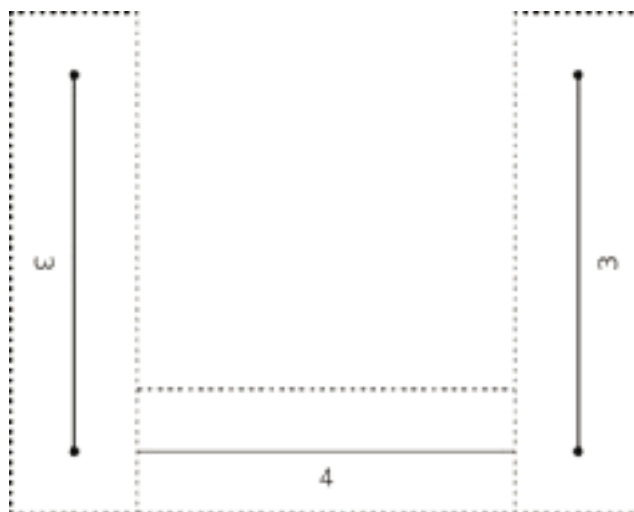

Explain to students that the sheet distributed to them is the 4-inch segment that is mentioned in the task statement and they will be drawing on that sheet.



If using the digital version of the activity, students will be using the Trace feature to see the path of the point. It is accessed by right-clicking on the point.

Access for Students with Disabilities

Action and Expression: Internalize Executive Functions. Begin with a small-group or whole-class demonstration of how to use the cardboard strips as an informal compass for drawing all the possible locations where the given segments could end.

Supports accessibility for: Memory; Conceptual processing

Student Task Statement

We'll explore a method for drawing a triangle that has three specific side lengths. Your teacher will give you a piece of paper showing a 4-inch segment as well as some instructions for which strips to use and how to connect them.

1. Follow these instructions to mark the possible endpoints of one side:
 - a. Put your 4-inch strip directly on top of the 4-inch segment on the piece of paper. Hold it in place.
 - b. For now, ignore the 3-inch strip on the left side. Rotate it so that it is out of the way.
 - c. In the 3-inch strip on the *right* side, put the tip of your pencil in the hole on the end that is not connected to anything. Use the pencil to move the strip around its hinge, drawing all the places where a 3-inch side could end.
 - d. Remove the connected strips from your paper.
2. What shape have you drawn while moving the 3-inch strip around? Why? Which tool in your geometry toolkit can do something similar?
3. Use your drawing to create two unique triangles, each with a base of length 4 inches and a side of length 3 inches. Use a different color to draw each triangle.
4. Reposition the strips on the paper so that the 4-inch strip is on top of the 4-inch segment again. In the 3-inch strip on the *left* side, put the tip of your pencil in the hole on the end that is not connected to anything. Use the pencil to move the strip around its hinge, drawing all the places where another 3-inch side could end.
5. Using a third color, draw a point where the two marks intersect. Using this third color, draw a triangle with side lengths of 4 inches, 3 inches, and 3 inches.

Student Response

1. Students draw the circle shown on the right side of the diagram.

2. A circle is all the points that are the same distance away from a center point. A compass can be used to draw this.
3. Answers vary. Possible response: Students draw the small red triangle and the large blue triangle shown in the diagram.
4. Students draw the circle shown on the left side of the diagram.
5. Answers vary. Possible response: Students draw the green or yellow triangle shown in the diagram.

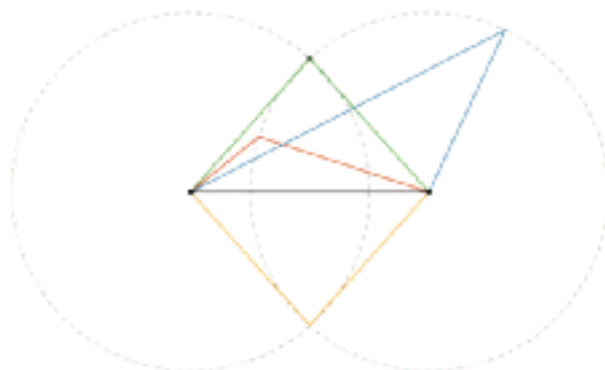

Activity Synthesis

Display a 4-inch strip connected to two 3-inch strips, positioned parallel to each other as pictured in the Launch. To help students connect the process of building with cardboard strips to drawing on paper, ask questions like:

- “If you want to *build* a triangle with these side lengths, how do you know at what angle to position the cardboard strips?” (Turn the sides until their unattached endpoints are touching.)
- “If you want to *draw* a triangle with these side length, how can you know at what angle to draw the sides?” (Find the point where both circles intersect.)
- “We have seen with the cardboard strips that an unknown angle works like a hinge. How is that represented in your drawing?” (with a circle centered on the endpoint of one segment and a radius the length of the other segment)

Select students to share their drawings with the class. To reinforce the patterns that students noticed in the previous activity, consider asking questions like these:

- “How many different triangles could we draw when we had only traced a circle on one side? Why?” (Lots of different triangles, because we were only using two of the given side lengths.)
- “What is the longest the third side could have been? And the shortest?” (Less the 7 inches; More than 1 inch)

- “How many different triangles could we draw once we had traced a circle on each side?” (It looked like there were 2 different triangles, but they are identical copies, so there’s really only 1 unique triangle.)
-

Access for English Language Learners

Speaking, Listening, Representing: MLR7 Compare and Connect. Use this routine to help students compare their processes for building and drawing their triangles. Ask students “What is the same and what is different?” about the approaches. Draw students’ attention to the connections between building and drawing such as: opening the hinge between the cardboard strips and drawing the circle using the compass. These exchanges strengthen students’ language use and reasoning from concrete to representational approaches.

Design Principle(s): Maximize meta-awareness

Lesson Synthesis

- When you are given side lengths and asked to draw a triangle, how can you get started? (Hold one length fixed and swing the other around in a circle.)
- If you draw one side of the triangle with circles (of the correct radius for the other two side lengths) on each end, what does it look like when it is impossible to make a triangle? (The two circles do not intersect, or they intersect at a point on the first line segment.)
- If you draw one side of the triangle with circles on each end, and the circles *do* cross, they will cross twice. Why do we say there’s only one possible triangle instead of two? (The two triangles are identical copies.)

7.4 Finishing Elena’s Triangles

Cool Down: 5 minutes

Addressing

- 7.G.A.2

Student Task Statement

Elena is trying to draw a triangle with side lengths 4 inches, 3 inches, and 5 inches.

- She uses her ruler to draw a 4 inch line segment AB .
- She uses her compass to draw a circle around point B with radius 3 inches
- She draws another circle, around point A with radius 5 inches.

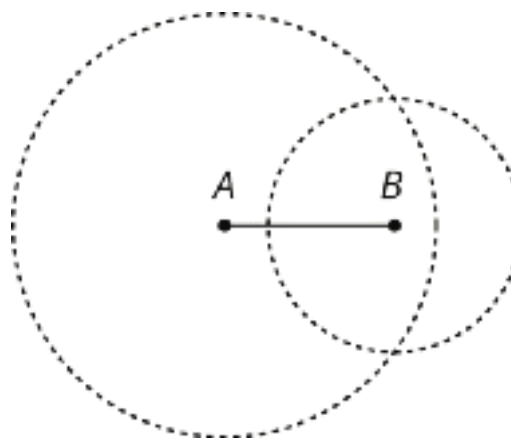

1. What should Elena do next? Explain and show how she can finish drawing the triangle.

Now Elena is trying to draw a triangle with side lengths 4 inches, 3 inches, and 8 inches.

- She uses her ruler to draw a 4 inch line segment AB .
- She uses her compass to draw a circle around point B with radius 3 inches.
- She draws another circle, around point A with radius 8 inches.

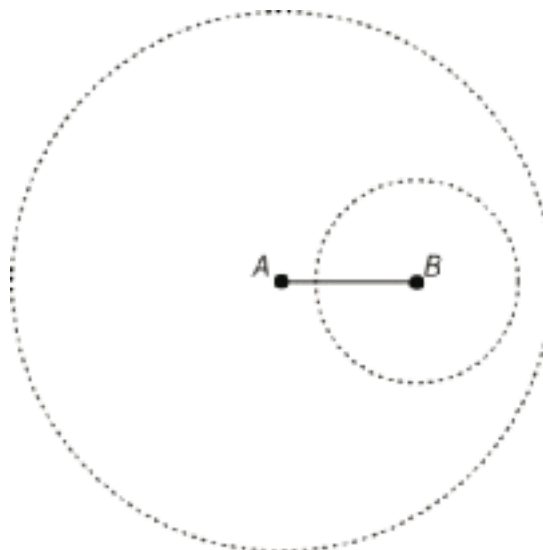

2. Explain what Elena's drawing means.

Student Response

1. Elena should put a point where the two circles intersect and draw line segments connecting that point to points A and B to finish her triangle.
2. Elena's drawing means that there is no way to draw a triangle with these side lengths. The circles do not intersect, because the side lengths of 3 inches and 4 inches are too short to make a triangle with the third side of 8 inches.

Student Lesson Summary

If we want to build a polygon with two given side lengths that share a vertex, we can think of them as being connected by a hinge that can be opened or closed:

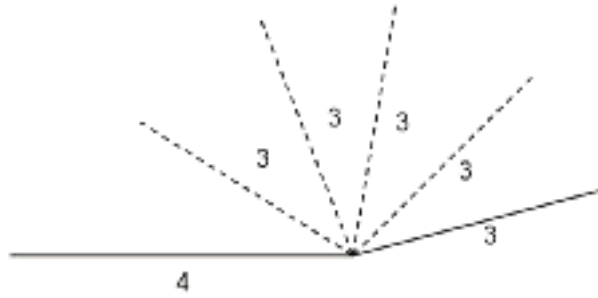

All of the possible positions of the endpoint of the moving side form a circle:

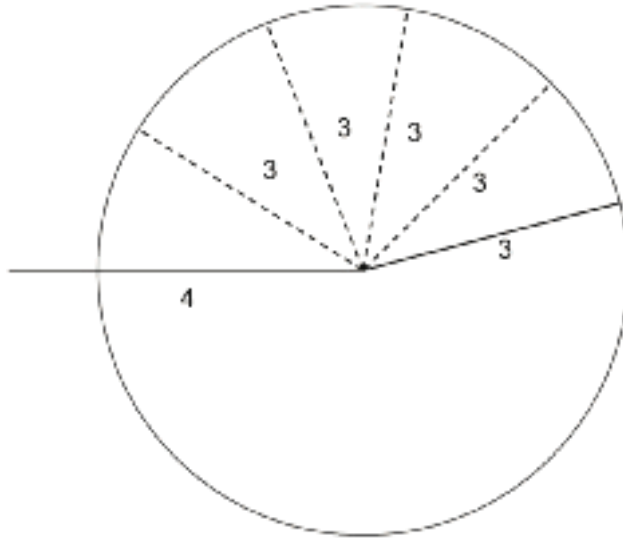

You may have noticed that sometimes it is not possible to build a polygon given a set of lengths. For example, if we have one really, really long segment and a bunch of short segments, we may not be able to connect them all up. Here's what happens if you try to make a triangle with side lengths 21, 4, and 2:



The short sides don't seem like they can meet up because they are too far away from each other.

If we draw circles of radius 4 and 2 on the endpoints of the side of length 21 to represent positions for the shorter sides, we can see that there are no places for the short sides that would allow them to meet up and form a triangle.

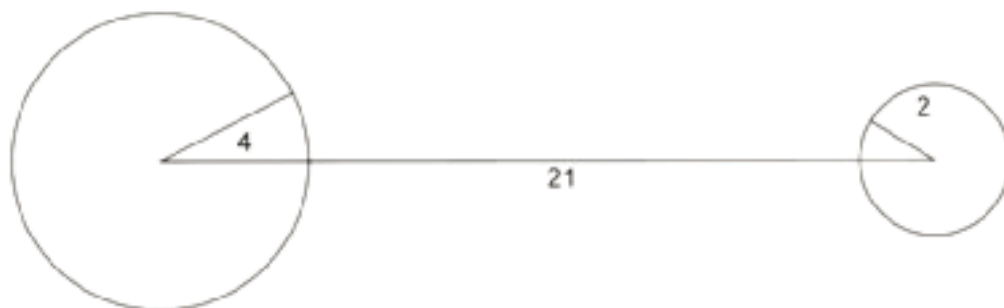

In general, the longest side length must be less than the sum of the other two side lengths. If not, we can't make a triangle!

If we *can* make a triangle with three given side lengths, it turns out that the measures of the corresponding angles will *always* be the same. For example, if two triangles have side lengths 3, 4, and 5, they will have the same corresponding angle measures.

Lesson 7 Practice Problems

Problem 1

Statement

In the diagram, the length of segment AB is 10 units and the radius of the circle centered at A is 4 units. Use this to create two unique triangles, each with a side of length 10 and a side of length 4. Label the sides that have length 10 and 4.

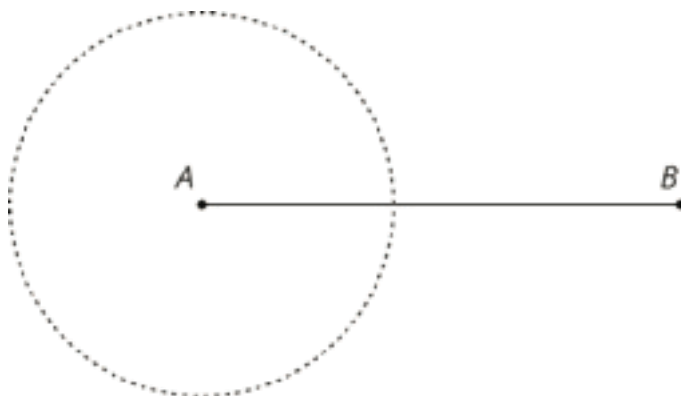

Solution

Answers vary. Possible response:

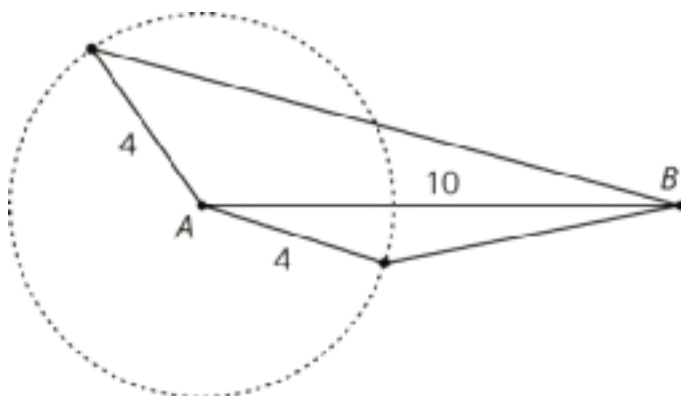

Problem 2

Statement

Select all the sets of three side lengths that will make a triangle.

- A. 3, 4, 8
- B. 7, 6, 12
- C. 5, 11, 13
- D. 4, 6, 12
- E. 4, 6, 10

Solution

["B", "C"]

Problem 3

Statement

Based on signal strength, a person knows their lost phone is exactly 47 feet from the nearest cell tower. The person is currently standing 23 feet from the same cell tower. What is the closest the phone could be to the person? What is the furthest their phone could be from them?

Solution

24 feet, 70 feet

Problem 4

Statement

Each row contains the degree measures of two complementary angles. Complete the table.

| measure of an angle | measure of its complement |
|---------------------|---------------------------|
| 80° | |
| 25° | |
| 54° | |
| x | |

Solution

| measure of an angle | measure of its complement |
|---------------------|---------------------------|
| 80° | 10° |
| 25° | 65° |
| 54° | 36° |
| x | $90 - x$ |

(From Unit 7, Lesson 2.)

Problem 5

Statement

Here are two patterns made using identical rhombuses. Without using a protractor, determine the value of a and b . Explain or show your reasoning.

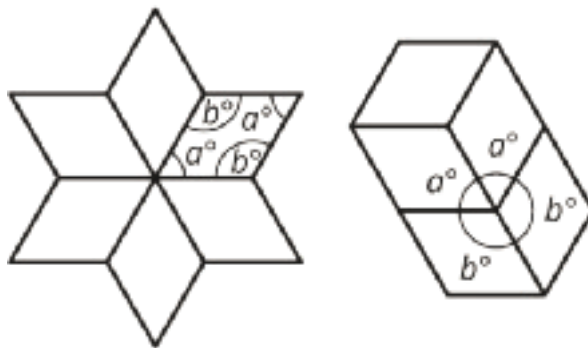

Solution

$a = 60$ because 6 a 's make 360. $b = 120$ because 2 a 's and 2 b 's make 360.

(From Unit 7, Lesson 1.)

Problem 6

Statement

Mai's family is traveling in a car at a constant speed of 65 miles per hour.

- At that speed, how long will it take them to travel 200 miles?
- How far do they travel in 25 minutes?

Solution

a. $3\frac{5}{65}$ hours or about 3 hours and 4.6 minutes ($200 \div 65$ hours)

b. $65 \cdot \frac{25}{60}$ miles or about 27.1 miles

(From Unit 4, Lesson 3.)

Lesson 8: Triangles with 3 Common Measures

Goals

- Describe, compare, and contrast (orally and in writing) triangles that share three common measures of angles or sides.
- Justify (orally and using other representations) whether triangles are identical copies or are “different” triangles.
- Recognize that examining which side lengths and angle measures are adjacent can help determine whether triangles are identical copies.

Learning Targets

- I understand that changing which sides and angles are next to each other can make different triangles.

Lesson Narrative

In this lesson, students examine sets of triangles in which all the triangles share 3 common measures of angles or sides. Students learn to recognize when triangles are “identical copies” that are oriented differently on the page, and when they are different triangles (meaning triangles that are not identical copies). This prepares them for trying to draw more than one triangle given 3 measures in the next lesson.

For example, suppose a triangle has angles that measure A and B and a side length that measures x . Here are 3 triangles that have these measures:



This example shows 2 “different triangles” (triangles that are not identical copies). The first two triangles are identical copies, so they are the same, but the third is not, so it is different than the other two.

Students see that the configuration of which sides and angles are adjacent to each other can help them decide whether triangles are identical copies or different triangles (not identical copies). In the example, the first two figures have angles A and B adjacent to side x . However, in the third figure angle B is no longer adjacent to side x . Here students can see that a good way to try to make a different triangle with the same 3 measures is to change which sides and angles are adjacent.

Students do not need to memorize how many different kinds of triangles are possible given different combinations of angles and sides, and they do not need to know criteria such as angle-side-angle for determining if two triangles are identical copies..

Alignments

Addressing

- 7.G.A.2: Draw (freehand, with ruler and protractor, and with technology) geometric shapes with given conditions. Focus on constructing triangles from three measures of angles or sides, noticing when the conditions determine a unique triangle, more than one triangle, or no triangle.

Instructional Routines

- MLR2: Collect and Display
- MLR8: Discussion Supports
- Think Pair Share

Required Materials

Geometry toolkits

For grade 6: tracing paper, graph paper, colored pencils, scissors, and an index card to use as a straightedge or to mark right angles.

For grades 7 and 8: everything in grade 6, plus a ruler and protractor. Clear protractors with no holes and with radial lines printed on them are recommended.

Notes: (1) "Tracing paper" is easiest to use when it's a smaller size. Commercially-available "patty paper" is 5 inches by 5 inches and ideal for this. If using larger sheets of tracing paper, consider cutting them down for student use. (2) When compasses are required in grades 6-8 they are listed as a separate Required Material.

Student Learning Goals

Let's contrast triangles.

8.1 3 Sides; 3 Angles

Warm Up: 10 minutes

The purpose of this warm-up is to begin looking at the different triangles that can be drawn when three measures are specified. The first set of triangles in this activity all share the same 3 side lengths. The second set of triangles all share the same 3 angle measures. Later in this lesson, students will look at sets of triangles that share some combination of side lengths and angle measures.

Addressing

- 7.G.A.2

Launch

Provide access to geometry toolkits. Give students 1 minute of quiet think time, followed by a whole-class discussion.

Anticipated Misconceptions

Some students may say that all the triangles in the second set are “the same shape.” This statement can result from two very different misconceptions. Listen to the students’ reasoning and explain as needed:

1. Just because they are all in the same category “triangles” doesn’t mean they are all the same shape. If we can take two shapes and position one exactly on top of the other, so all the sides and corners line up, then they are identical copies.
2. These triangles are scaled copies of each other, but that does not make them “the same” because their side lengths are still different. Only scaled copies made using a scale factor of 1 are identical copies.

Student Task Statement

Examine each set of triangles. What do you notice? What is the same about the triangles in the set? What is different?

Set 1:

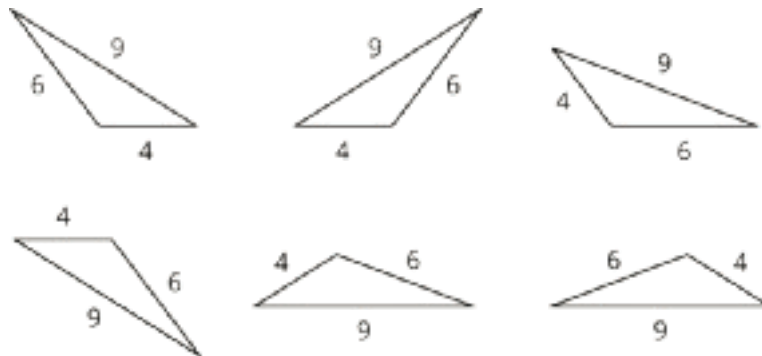

Set 2:

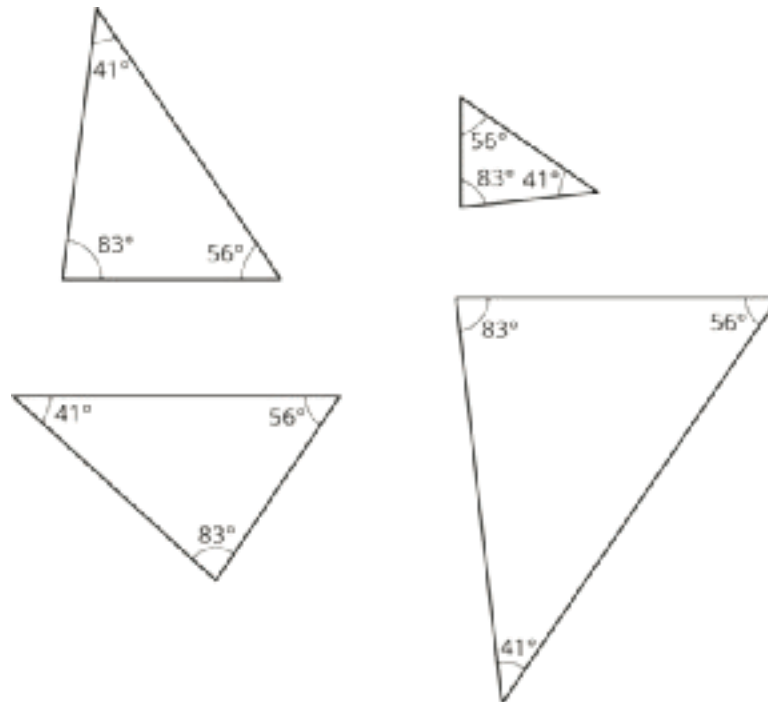

Student Response

1. All of the side lengths and angles are the same size. These triangles are identical copies. The triangles face different directions.
2. These triangles all have the same angles, but different side lengths. They could be scaled copies that are oriented differently.

Activity Synthesis

Invite students to share things they notice, things that are the same and things that are different about the triangles. Record and display these ideas for all to see.

If these discussion points do not come up in students' explanations make them explicit:

In the first set:

- All the triangles are identical copies, just in different orientations.
- They have the same 3 side lengths.
- They have the same 3 angle measures (can be checked with tracing paper or a protractor).

In the second set:

- The triangles are not identical copies.
 - Note: Students may recognize that these triangles are scaled copies of each other, since they have the same angle measures. However, this is the first time students have seen scaled copies in different orientations, and it is not essential to this lesson that students recognize that these triangles are scaled copies.

- They have the same 3 angle measures.
- They have different side lengths (can be checked with tracing paper or a ruler).

The goal is to make sure students understand that the second set has 3 different triangles (because they are different sizes) and the first set really only shows 1 triangle in many different orientations. Tracing paper may be helpful to convince students of this.

8.2 2 Sides and 1 Angle

15 minutes

In this activity, students examine different orientations of triangles that all share 2 sides lengths and one angle measure. They recognize that some of these triangles are identical copies and others are different triangles (not identical copies).

In the coming lessons, students are asked to draw their own triangles. On their own, students often have trouble thinking about triangles where the three given conditions are not included adjacent to one another. For example, when given two sides and an angle, many students will immediately think of putting the given angle between the two sides, but struggle with visualizing putting the angle anywhere else. This task is important for helping students view this as a viable option.

Addressing

- 7.G.A.2

Instructional Routines

- MLR2: Collect and Display
- Think Pair Share

Launch

Arrange students in groups of 2. Give students 2–3 minutes of quiet work time followed by time to discuss their explanations with a partner. Follow with a whole-class discussion. Provide access to geometry toolkits.

Access for Students with Disabilities

Representation: Develop Language and Symbols. Use virtual or concrete manipulatives to connect symbols to concrete objects or values. Provide students with a printed copy of the triangles for them to cut out and rearrange to determine the number of different triangles.

Supports accessibility for: Conceptual processing

Access for English Language Learners

Conversing: MLR2 Collect and Display. As students discuss their explanations with a partner, listen for and collect vocabulary, gestures, and diagrams students use to identify and describe the similarities and differences between them. Capture student language that reflects a variety of ways to describe the differences between triangles and the relative position of sides and angles. Write the students' words on a visual display and update it throughout the remainder of the lesson. Remind students to borrow language from the display as needed. This will help students read and use mathematical language during their paired and whole-class discussions.

Design Principle(s): Optimize output (for explanation); Maximize meta-awareness

Anticipated Misconceptions

Some students may say that there are 9 different triangles, because they do not recognize that some of them are identical copies oriented differently. Prompt them to use tracing paper to compare the triangles.

Student Task Statement

Examine this set of triangles.

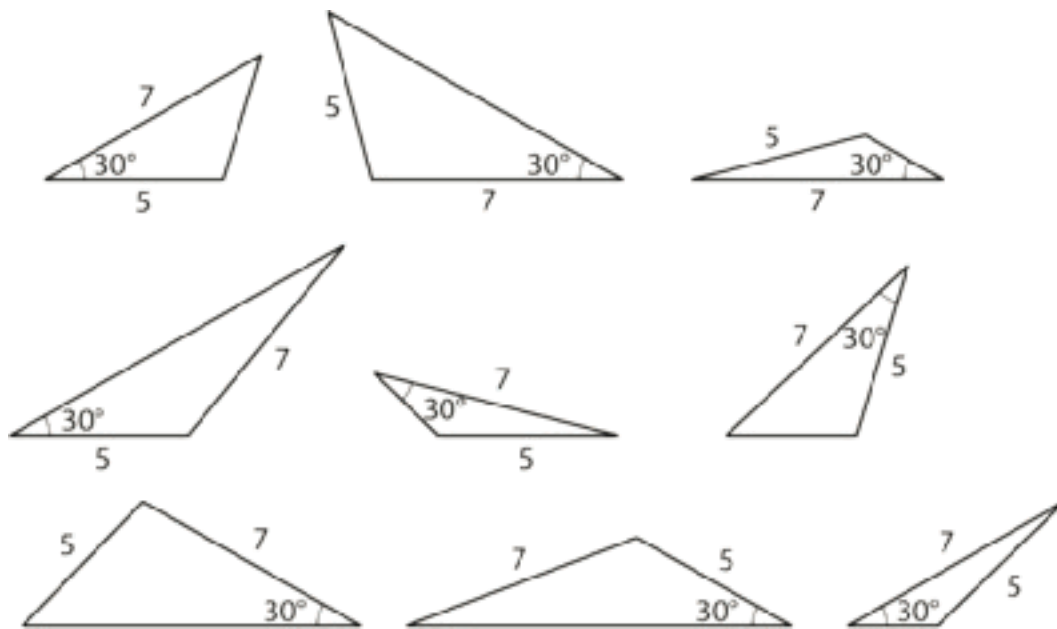

1. What is the same about the triangles in the set? What is different?
2. How many different triangles are there? Explain or show your reasoning.

Student Response

1. All of the triangles have two sides that are the same length and one angle that is the same measure. The triangles are oriented differently and the two sides and one angle are in a different order.
2. There are 4 different triangles.

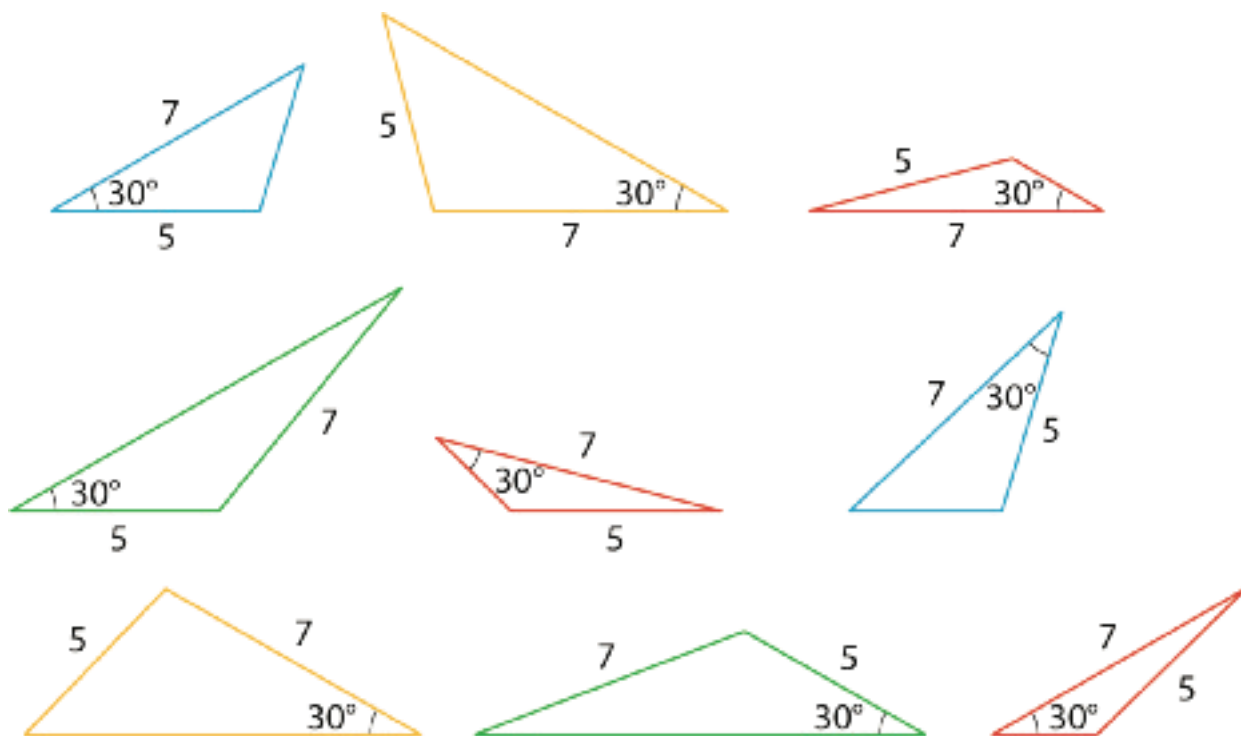

Sample Explanation:

- The triangles marked in blue have the common measurements in the order 7 cm, 30° , 5 cm.
- The triangles marked in green have the common measurements in the order 30° , 5 cm, 7 cm.
- The triangles marked in both yellow and red have the common measurements in the order 30° , 7 cm, 5 cm, but the yellow triangles are larger and the red triangles are smaller.

Activity Synthesis

Select students to share the similarities and differences between the triangles in the set.

Trace a few of the triangles from the set and show how you can turn, flip, or move some of them to line up while others cannot be lined up. Ask students what this means about all the triangles in the set (they are not all identical to each other). Explain that, "While there are certainly times when the position of a triangle is important ('I wouldn't want my roof upside down!'), for this unit in geometry, we will consider shapes the same if they are identical copies."

To highlight the differences among the triangles, ask students:

- “Is there only one possible triangle that could be created from the given conditions?” (No, there were 4.)
- “How would you explain what is different about these four triangles?” (Some have the 30° angle between the two sides of known length and others have the 30° angle next to the side of unknown length.)

Explain to students that it seems the order in which the conditions are included in the triangle (for example, is the angle between the two sides or not?) matters in creating different triangles. Emphasize that the three required pieces (2 sides and 1 angle) do not have to all be put next to one another. When they are asked to draw triangles with three or more conditions, they should consider the way in which the conditions are arranged in their drawing. For example, think about whether the given angle must go between the two sides or not.

8.3 2 Angles and 1 Side

10 minutes

This activity is similar to what students did in the previous activity; however, here the conditions given are 2 angles and 1 side.

Addressing

- 7.G.A.2

Instructional Routines

- MLR8: Discussion Supports

Launch

Keep students in the same groups. Tell students that this activity is similar to the previous one, and they should pay close attention to what they find different here. Provide access to geometry toolkits. Give students 2–3 minutes of quiet work time followed by time to discuss their explanations with a partner. Follow with a whole-class discussion.

Access for Students with Disabilities

Engagement: Develop Effort and Persistence. Encourage and support opportunities for peer interactions. Invite students to talk about their ideas with a partner before writing them down. Display sentence frames to support students when they explain their strategy. For example, “Both ____ and ____ are alike because . . .”, “____ and ____ are different because . . .”

Supports accessibility for: Language; Social-emotional skills

Anticipated Misconceptions

Some students may say there are only 2 different triangles in this set, because they do not notice the slight size difference between the smaller two groups of triangles. Prompt them to look at where the 80° angle is located in comparison to the 6 cm side.

Student Task Statement

Examine this set of triangles.

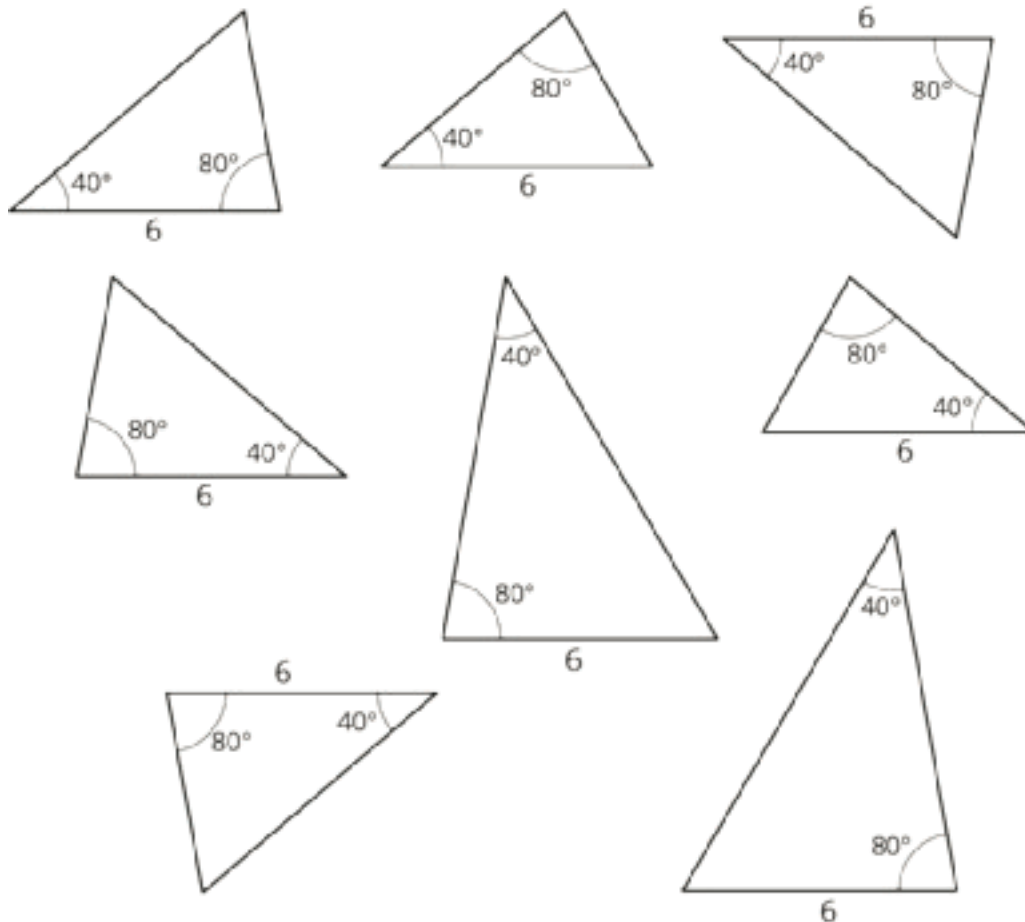

1. What is the same about the triangles in the set? What is different?
2. How many different triangles are there? Explain or show your reasoning.

Student Response

1. All of the triangles have one side that is the same length and two angles that have the same measure. The triangles are oriented differently and the one side and two angles are in a different order.
2. There are 3 different triangles.

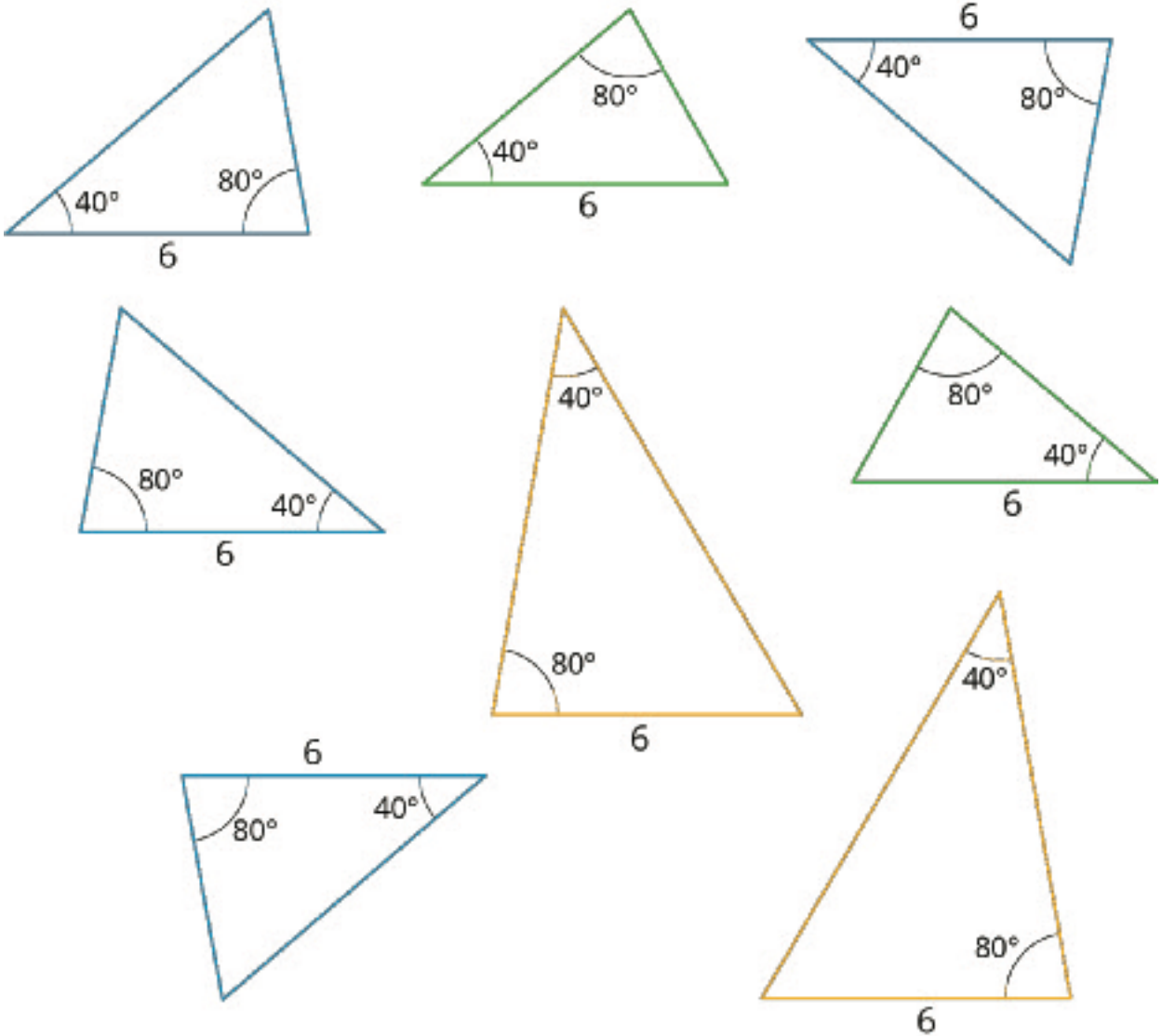

Sample explanation:

- The triangles marked in blue have the common measurements in the order 40° , 6 cm, 80° .
- The triangles marked in yellow have the common measurements in the order 40° , 80° , 6 cm.
- The triangles marked in green have the common measurements in the order 80° , 40° , 6 cm.

Activity Synthesis

Ask a few students to share how many different triangles they think are in this set. Select students to share the similarities and differences between triangles in the set. If necessary, trace a few triangles from the set and show how you can turn, flip, or move some of them to line up while others cannot be lined up. Ask students what this means about all the triangles in the set (they are not all identical to each other).

To highlight the differences among the triangles ask students:

- “What differences do you see between the triangles in this activity and the triangles in the previous activity?” (The given conditions here were 2 angles and 1 side, the previous activity was 2 sides and 1 angle.)
- “What similarities do you see between the triangles in this activity and the triangles in the previous activity?” (These triangles have all the same conditions but in a different order, and they made different triangles as was seen in the previous activity.)

If time permits, consider asking students to use a protractor to measure the unlabeled angle from each of the three different triangles. Discuss what they notice about the third angle. (It’s the same size in every triangle.)

Explain to students that here we see another example of different triangles that can be made using the same conditions (2 angles and 1 side) in different orders (side between the two angles, side next to the 40 degree angle and side next to the 80 degree angle). Tell them that in upcoming lessons we will continue to investigate what they noticed here with the addition of drawing the different triangles.

Access for English Language Learners

Speaking: MLR8 Discussion Supports. Use this routine to amplify mathematical uses of language to communicate about similar triangles. As students share the similarities and differences they noticed about the triangles, invite other students to press for details, challenge an idea, elaborate on an idea, or give an example of their own process. Revoice student ideas to demonstrate mathematical language when necessary. This will help students produce and make sense of the language needed to communicate their own ideas.

Design Principle(s): Optimize output (for explanation)

Lesson Synthesis

- For what we have done today, what does it mean for two triangles to be “different?” (They are not identical copies.)
- If you have a drawing of two triangles, how can you tell if they are identical copies? (If I trace one triangle and can move the tracing to perfectly line up with the other, then they are identical copies.)
- When trying to draw different triangles with the same set of conditions, what are some things to try? (Change the order of the conditions in the triangle.)

8.4 Comparing Andre and Noah’s Triangles

Cool Down: 5 minutes

Addressing

- 7.G.A.2

Student Task Statement

Andre and Noah each drew a triangle with side lengths of 5 cm and 3 cm and an angle that measures 60° , and then they showed each other their drawings.

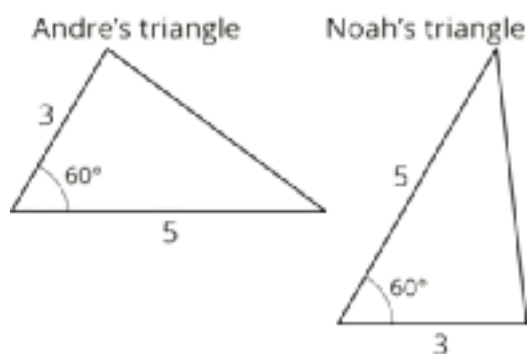

1. Did Andre and Noah draw different triangles? Explain your reasoning.
2. Explain what Andre and Noah would have to do to draw another triangle that is different from what either of them has already drawn.

Student Response

1. These are both the same triangle. In both cases, the 60° angle is between the 3 cm and 5 cm sides. If you trace one triangle, flip it and turn it, it can line up exactly with the other triangle.
2. To draw a different triangle, they should try putting the 60° angle next to the side of unknown length, instead of between the two known sides.

Student Lesson Summary

Both of these quadrilaterals have a right angle and side lengths 4 and 5:

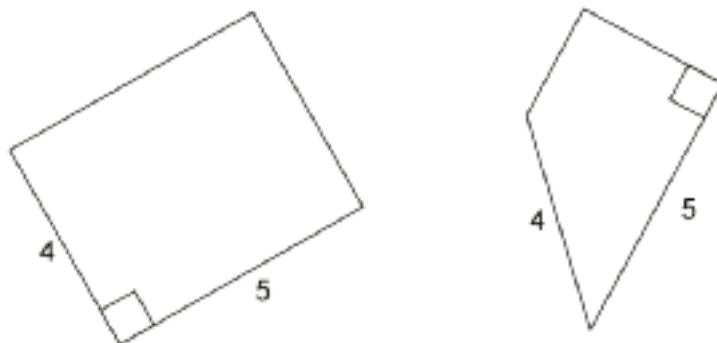

However, in one case, the right angle is *between* the two given side lengths; in the other, it is not.

If we create two triangles with three equal measures, but these measures are not next to each other in the same order, that usually means the triangles are different. Here is an example:

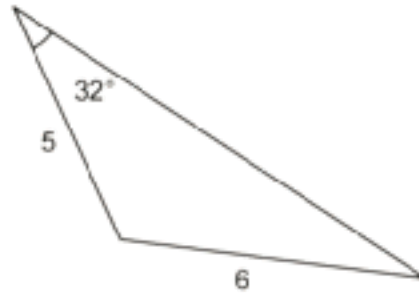
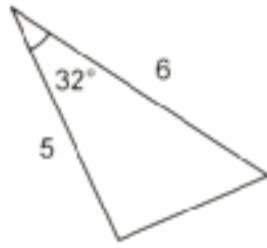

Lesson 8 Practice Problems

Problem 1

Statement

Are these two triangles identical? Explain how you know.

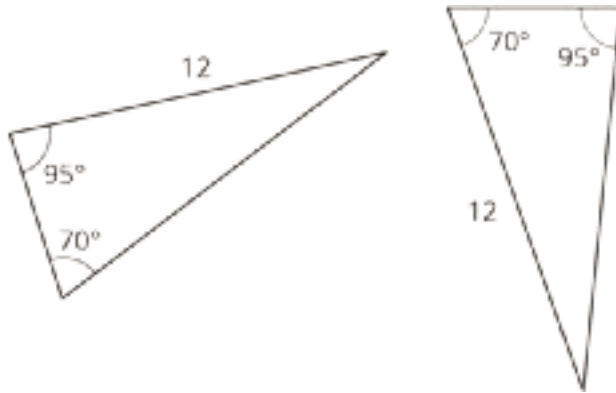

Solution

No, these two triangles are not identical. They have two of the same angle measures and one side length is the same, but the sides and angles are arranged differently in each triangle. In the triangle on the left, the side marked 12 is adjacent to the 95° angle. In the triangle on the right, the side marked 12 is adjacent to the 70° angle.

Problem 2

Statement

Are these triangles identical? Explain your reasoning.

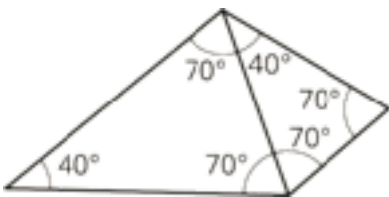

Solution

No, they are not identical. Although they have the same angle measurements, two of the side lengths are different.

Problem 3

Statement

Tyler claims that if two triangles each have a side length of 11 units and a side length of 8 units, and also an angle measuring 100° , they must be identical to each other. Do you agree? Explain your reasoning.

Solution

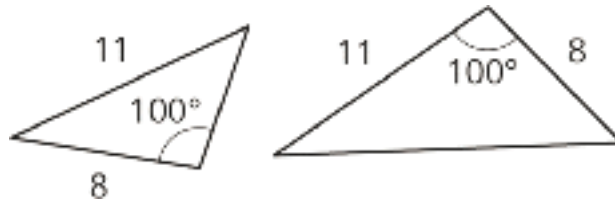

No, it is possible to build two different triangles with these measurements.

Problem 4

Statement

The markings on the number line are equally spaced. Label the other markings on the number line.



Solution

-9, -6, -3, 0, 3, 6, 9, 12, 15

(From Unit 5, Lesson 8.)

Problem 5

Statement

A passenger on a ship dropped his camera into the ocean. If it is descending at a rate of -4.2 meters per second, how long until it hits the bottom of the ocean, which is at $-1,875$ meters?

Solution

It will take about 446 seconds, which is about 7 and a half minutes.

(From Unit 5, Lesson 9.)

Problem 6

Statement

Apples cost $\$1.99$ per pound.

- a. How much do $3\frac{1}{4}$ pounds of apples cost?
- b. How much do x pounds of apples cost?
- c. Clare spent \$5.17 on apples. How many pounds of apples did Clare buy?

Solution

- a. \$6.47 (this number is rounded to the nearest cent)
- b. $1.99x$
- c. About 2.6 pounds. $1.99x = 5.17$, so $x \approx 2.598$. Most grocery store scales round to the nearest tenth.

(From Unit 4, Lesson 3.)

Problem 7

Statement

Diego has a glue stick with a diameter of 0.7 inches. He sets it down 3.5 inches away from the edge of the table, but it rolls onto the floor. How many rotations did the glue stick make before it fell off of the table?

Solution

$3.5 \div 2.2$ times (about 1.6 times)

(From Unit 3, Lesson 5.)

Lesson 9: Drawing Triangles (Part 1)

Goals

- Draw triangles with two given angle measures and one side length, and describe (orally) how many different triangles could be drawn with the given conditions.
- Use drawings to justify (in writing) whether two given angle measures and one side length determine one unique triangle.

Learning Targets

- Given two angle measures and one side length, I can draw different triangles with these measurements or show that these measurements determine one unique triangle or no triangle.

Lesson Narrative

In the previous lesson, students were given collections of triangles and noticed that they shared angle and side measures, and that sometimes there was more than one type of triangle with the same measures. In this lesson and the next, they build on that experience by drawing their own triangles with specified measures: a given angle, two given angles, and two given angles and a given side length. The purpose of the two lessons is to give students experience using various tools to draw triangles with given conditions, and to help them see that sometimes the given conditions allow only one possible triangle, sometimes more than one, and that sometimes none. Note that in grade 7, students are not expected to know that the angles within a triangle sum to 180° , although it is fine for them to use that information if they know it.

Alignments

Addressing

- 7.G.A: Draw, construct, and describe geometrical figures and describe the relationships between them.
- 7.G.A.2: Draw (freehand, with ruler and protractor, and with technology) geometric shapes with given conditions. Focus on constructing triangles from three measures of angles or sides, noticing when the conditions determine a unique triangle, more than one triangle, or no triangle.

Instructional Routines

- MLR7: Compare and Connect
- MLR8: Discussion Supports
- Which One Doesn't Belong?

Required Materials

Geometry toolkits

For grade 6: tracing paper, graph paper, colored pencils, scissors, and an index card to use as a straightedge or to mark right angles.

For grades 7 and 8: everything in grade 6, plus a ruler and protractor. Clear protractors with no holes and with radial lines printed on them are recommended.

Notes: (1) "Tracing paper" is easiest to use when it's a smaller size. Commercially-available "patty paper" is 5 inches by 5 inches and ideal for this. If using larger sheets of tracing paper, consider cutting them down for student use. (2) When compasses are required in grades 6-8 they are listed as a separate Required Material.

Student Learning Goals

Let's see how many different triangles we can draw with certain measurements.

9.1 Which One Doesn't Belong: Triangles

Warm Up: 5 minutes

This warm-up prompts students to compare four images. It encourages students to explain their reasoning, hold mathematical conversations, and gives you the opportunity to hear how they use terminology and talk about characteristics of the images in comparison to one another. To allow all students to access the activity, each image has one obvious reason it does not belong. Encourage students to move past the obvious reasons (e.g., Figure A has 3 equal angles) and find reasons based on geometrical properties (e.g., Figure A is the only figure whose sides seem to have equal length). During the discussion, listen for important ideas and terminology that will be helpful in upcoming work of the lesson.

Addressing

- 7.G.A

Instructional Routines

- Which One Doesn't Belong?

Launch

Arrange students in groups of 2–4. Display the image for all to see. Ask students to indicate when they have noticed one image that doesn't belong and can explain why. Give students 2 minutes of quiet think time and then time to share their thinking with their group. After everyone has conferred in groups, ask the group to offer at least one reason each image doesn't belong.

Student Task Statement

Which one doesn't belong?

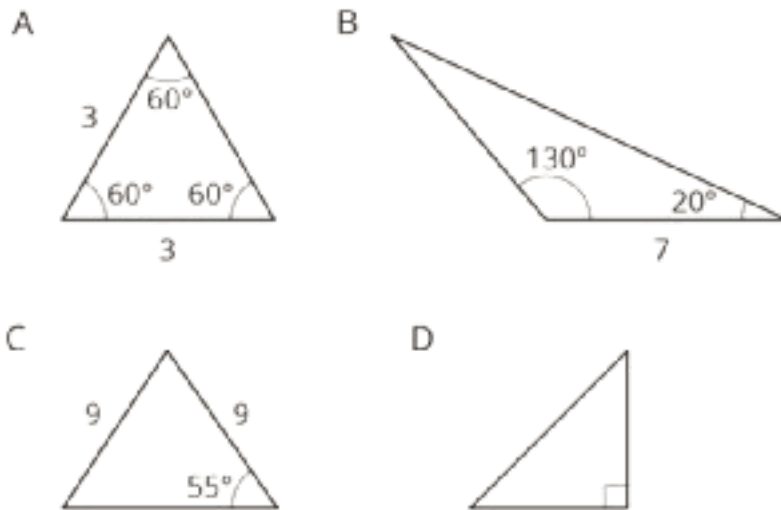

Student Response

Answers vary. Sample responses:

Figure 1 doesn't belong because:

- All the angles are equal to each other.
- All of the side lengths appear to be equal.

Figure 2 doesn't belong because:

- Only triangle with an obtuse angle.
- Only triangle with two angle measurements given.

Figure 3 doesn't belong because:

- Only triangle with two sides equal to each other (but not three)
- Only one angle measurement is given.

Figure 4 doesn't belong because:

- Only triangle with a right angle.
- No side lengths are given.

Activity Synthesis

Ask each group to share one reason why a particular image does not belong. Record and display the responses for all to see. After each response, poll the class if they agree or disagree. Since there is no single correct answer to the question of which one does not belong, attend to students'

explanations and ensure the reasons given are correct. During the discussion, ask students to explain the meaning of any terminology they use. Also, press students on unsubstantiated claims.

9.2 Does Your Triangle Match Theirs?

15 minutes (there is a digital version of this activity)

In this activity, students continue the work from the previous lesson by creating triangles from given conditions and seeing if it will match a given triangle. This activity transitions from students just noticing things about triangles already drawn to students drawing triangles themselves to test whether conditions result in unique triangles.

As student work on the task, monitor for students who draw different triangles than each other.

Addressing

- 7.G.A.2

Instructional Routines

- MLR8: Discussion Supports

Launch

Arrange students in groups of 2. Give students 3–5 minutes of quiet work time followed by time to check with their partner and discuss whether any of the triangles they drew are identical copies. Follow with whole-class discussion. Provide access to geometry toolkits, including rulers marked with centimeters and protractors.

Students using the digital version can create new triangles by dragging the vertices of the equilateral triangle in the applet. The measurements will be made for them, allowing them to focus on the new ideas.

Access for Students with Disabilities

Representation: Internalize Comprehension. Begin the activity with concrete or familiar contexts: Remind students to be measuring with centimeters and demonstrate how to use a protractor to draw the given angle.

Supports accessibility for: Conceptual processing; Memory

Anticipated Misconceptions

Students may have trouble recognizing that Lin's triangle could have the pieces described in different orders. They are likely to immediately think of the side being between the two angles and not visualize other arrangements. Remind students of the task from the previous day and some of the triangles they saw there.

Student Task Statement

Three students have each drawn a triangle. For each description:

- Draw a triangle with the given measurements.
- Measure and label the other side lengths and angle measures in your triangle.
- Decide whether the triangle you drew must be an identical copy of the triangle that the student drew. Explain your reasoning.

1. Jada's triangle has one angle measuring 75° .
2. Andre's triangle has one angle measuring 75° and one angle measuring 45° .
3. Lin's triangle has one angle measuring 75° , one angle measuring 45° , and one side measuring 5 cm.

Student Response

Answers vary. Sample response:

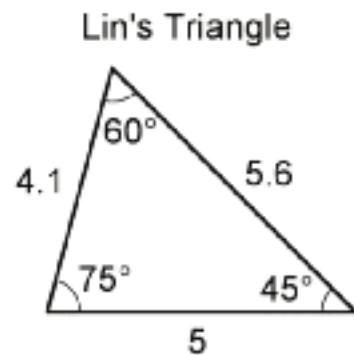
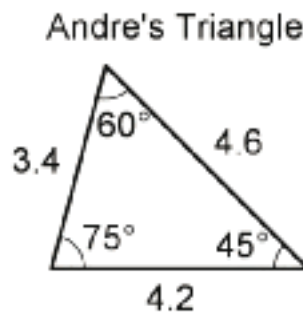
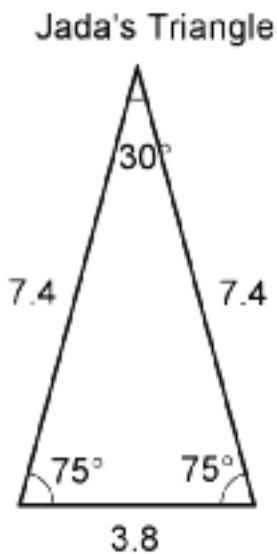

None of the triangles are guaranteed to be identical copies.

- The description of Jada's triangle is very vague. You can choose lots of other angles and side lengths.
- The description of Andre's triangle makes it so you can't choose the third angle measure (so all the drawings will be scaled copies), but you can still choose different sizes for the side lengths.
- The description of Lin's triangle might seem unique at first glance, but actually you could make any of the three sides be the 5 cm length, so you can still draw more than 1 triangle given these conditions.

Activity Synthesis

Select previously identified students to share their triangles.

To highlight the fact that there could be different triangles drawn, ask:

- “Did anybody draw a triangle that was identical to one drawn by their partner?”
- “Do we know enough about Jada’s triangle to draw an identical copy of it? Andre’s triangle? Lin’s triangle?” (no)

If not mentioned by students, explain that it could be possible that we all drew identical copies for Lin’s triangle (because it is most straightforward to draw the 5 cm side in between the 75° and 45° angles). However, that does not mean that we were given enough information about Lin’s triangle to draw an identical copy of it. The problem did not say that we had to put the 5 cm side between those two angles.

Display the image of Lin’s triangle for all to see. Invite students to confirm that it matches the description of Lin’s triangle. Ask whether any student drew an identical copy of Lin’s triangle.

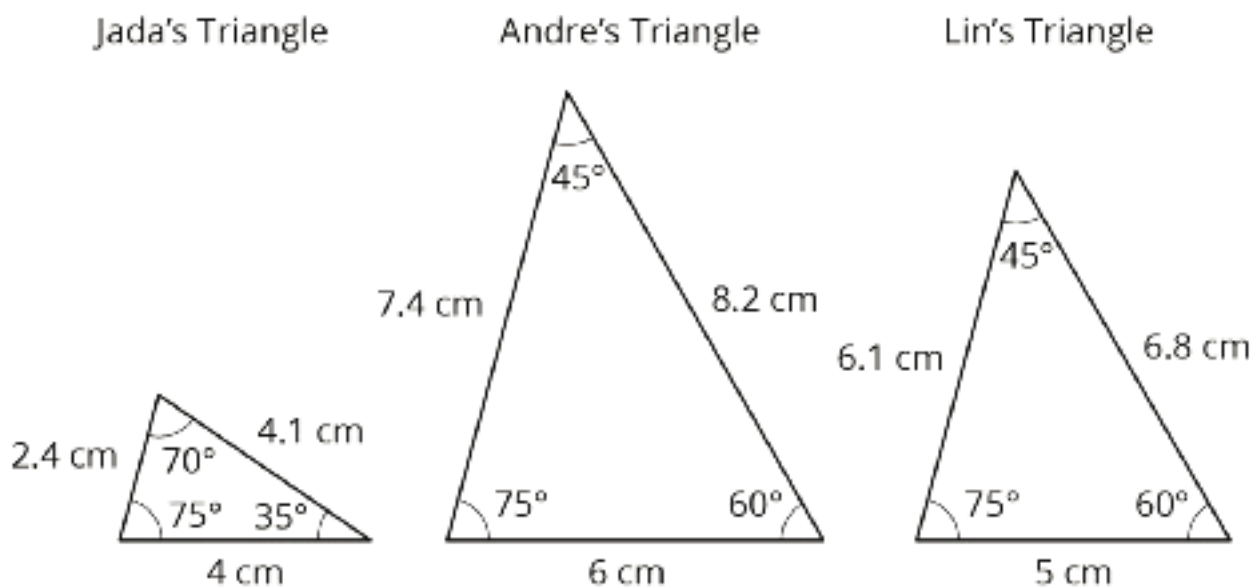

Introduce the word “unique.” Explain to students that in all three cases, the information given is not enough to determine a unique triangle, not even for Lin’s triangle, because there is more than 1 way we can draw a triangle with those given conditions. Ask students “what information would Lin have to give us to make the triangle unique (so we knew our drawing would be an identical copy of her triangle)?”

Before moving on to the next activity, it would be helpful to model how Lin drew her triangle:

1. Draw the 5 cm segment.
2. Draw the 75° angle on one end of the segment, with a very long ray.
3. Place a protractor along the ray.

4. Line up a ruler at the 45° measure on the protractor.
5. Keeping the ruler and protractor together, slide them along the ray until the edge of the ruler intersects with the other end of the 5 cm segment.
6. Keeping the ruler in place on the paper, remove the protractor from underneath.
7. Draw a line along the ruler from the ray to the segment.

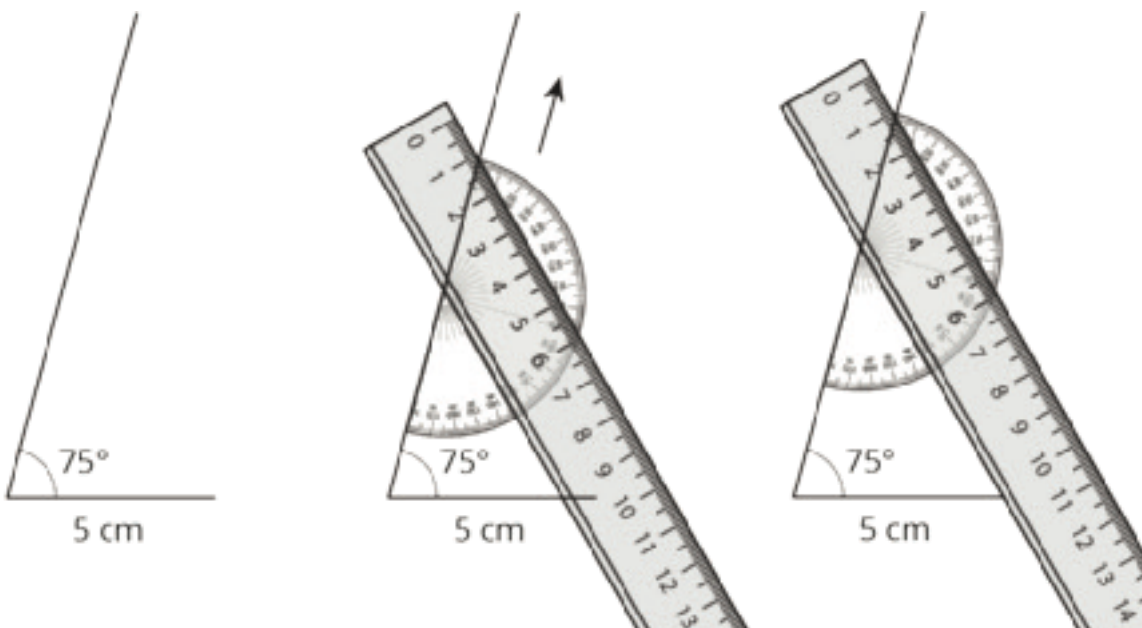

Access for English Language Learners

Speaking, Listening: MLR8 Discussion Supports. Use this routine to help students explain whether any of the triangles they drew are identical copies to Jada's, Andre's or Lin's triangles. Provide sentence frames such as: "I noticed ___ so I ..."; "This triangle is/isn't identical because..." These help students use mathematical language related to triangles (e.g., angle, side) to reason about whether their triangle is identical to a given triangle.

Design Principle(s): Optimize output (for explanation); Maximize meta-awareness

9.3 How Many Can You Draw?

15 minutes (there is a digital version of this activity)

In this activity, students are asked to draw as many different triangles as they can with the given conditions. The purpose of this activity is to provide an opportunity for students to see the three main results for this unit: a situation in which only a unique triangle can be made, a situation in which it is impossible to create a triangle from the given conditions, and a situation in which multiple triangles can be created from the conditions.

Students are not expected to remember which conditions lead to which results, but should become more familiar with some methods for attempting to create different triangles. They will practice including various conditions into the triangles, including the conditions in different combinations, and recognizing when the resulting triangles are identical copies or not.

Addressing

- 7.G.A.2

Instructional Routines

- MLR7: Compare and Connect

Launch

Keep students in same groups. Tell students they must try at least two different times to draw a triangle with the measurements given in each problem. Give students 5 minutes of quiet work time followed by time to discuss their different triangles with a partner. Follow with a whole-class discussion. Provide access to geometry toolkits.

Access for Students with Disabilities

Action and Expression: Internalize Executive Functions. Provide students with a printed graphic organizer to categorize the different triangles by condition.

Supports accessibility for: Language; Organization

Anticipated Misconceptions

Some students may draw two different orientations of the same triangle for the third set of conditions, with the 4 cm side in between the 60° and 90° angles. Prompt them to use tracing paper to check whether their two triangles are really different (not identical copies).

Some students may say the third set of measurements determines one unique triangle, because they assume the side length must go between the two given angle measures. Remind them of the discussion about Lin's triangle in the previous activity.

Student Task Statement

1. Draw as many different triangles as you can with each of these sets of measurements:
 - a. Two angles measure 60° , and one side measures 4 cm.
 - b. Two angles measure 90° , and one side measures 4 cm.
 - c. One angle measures 60° , one angle measures 90° , and one side measures 4 cm.
2. Which of these sets of measurements determine one unique triangle? Explain or show your reasoning.

Student Response

1. Answers vary. Sample responses:

a. Two orientations of the same triangle.

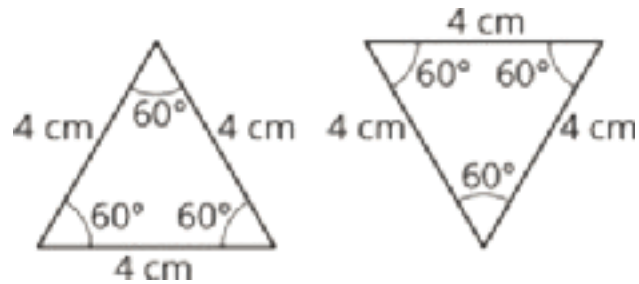

b. Two attempts to draw a triangle with two 90° angles and a 4 cm side. There is no possible triangle with these conditions.

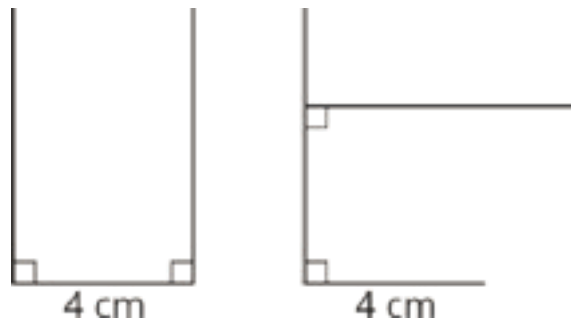

c. Three different triangles can be made with the conditions.

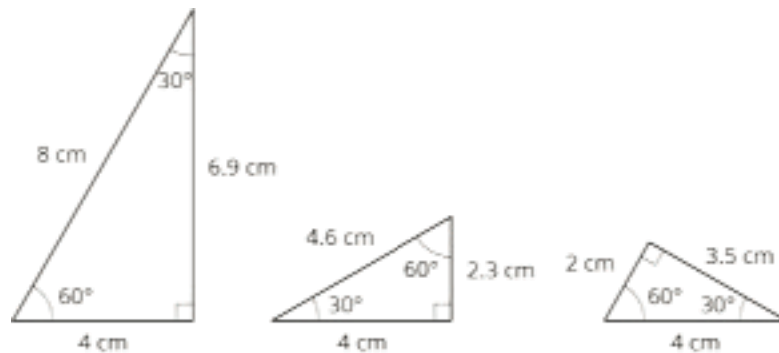

2. Only the first set of measurements determine a unique triangle.

Are You Ready for More?

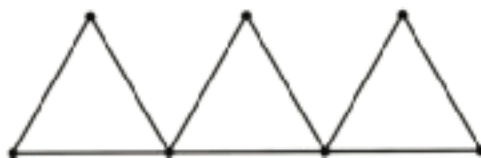

In the diagram, 9 toothpicks are used to make three equilateral triangles. Figure out a way to move only 3 of the toothpicks so that the diagram has exactly 5 equilateral triangles.

Student Response

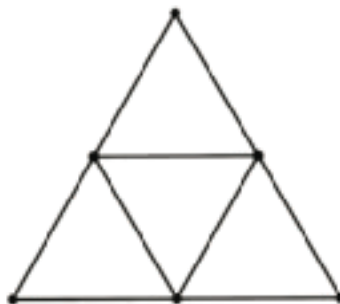

There are four small equilateral triangles and one large one.

Activity Synthesis

Ask students to indicate how many *different* triangles (triangles that are not identical copies) they could draw for each set of conditions. Select students to share their drawings and reasoning about the uniqueness of each problem. Discuss methods students used to try to think about other triangles that might fit the conditions.

Consider asking some of the following questions:

- “Which conditions produced a unique triangle?” (the first set of conditions)
- “Were there conditions that produced more than one triangle?” (the third set of conditions)
- “Were there conditions you could not draw a triangle for?” (the second set of conditions)
- “Why could you not draw a triangle for the second set of conditions?” (because two sides are parallel and will never intersect)

If not mentioned by students, explain to students that for the third set of conditions it is possible that all students drew identical copies using the 4 cm length as the side between the 60° and 90° angles. Consider asking them to think of the previous activity and to try to draw the triangle the way Lin would.

In grade 7, students do not need to know that the angles within a triangle sum to 180° . Tell them that next year they will learn more about why these different conditions determine different numbers of triangles.

Access for English Language Learners

Speaking: MLR7 Compare and Connect. Use this routine to compare and contrast the different ways students reasoned about the uniqueness of the constructed triangles. Ask students to consider what is the same and what is different about the triangles produced for each condition. Draw students' attention to the association between the conditions given and the ability to construct unique, many, or no triangles. In this discussion, model the language used to make sense of the conditions that resulted in the three different scenarios. These exchanges strengthen students' mathematical language use and supports them to compare geometric shapes.

Design Principle(s): Maximize meta-awareness; Support sense-making

Lesson Synthesis

- Sometimes a set of conditions result in a unique triangle. What other results can come from a set of conditions? (It could be impossible or make multiple triangles.)
- If you are given a side length and two angles, what would you do to try to get started making different triangles? (Draw a line segment with the given length and put the two angles on each end. Then I would try leaving one angle on one end, but using Lin's method of using a protractor and sliding it along for the other angle to create a triangle. Finally, I would do something similar, but switch which angle is next to the given length.)

9.4 Checking Diego's Triangle

Cool Down: 5 minutes

Addressing

- 7.G.A.2

Anticipated Misconceptions

Students may say that they do not agree with Diego's triangle, because the side length labeled 8 cm does not print at exactly 8 cm.

Student Task Statement

When asked to draw a triangle with two 45° angles and a side length of 8 cm, Diego drew this triangle.

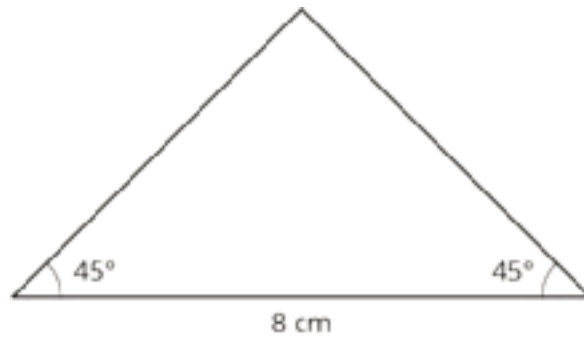

1. Do you agree with Diego's answer?
2. Is there a different triangle Diego could have drawn that would answer the question? Explain or show your reasoning.

Student Response

1. Yes, I agree that Diego's triangle has two 45° angles and a side length of 8 cm.
2. There is another possible triangle. Diego could keep one 45° angle next to the 8 cm side, but move the other one across from the 8 cm side.

Student Lesson Summary

Sometimes, we are given two different angle measures and a side length, and it is impossible to draw a triangle. For example, there is no triangle with side length 2 and angle measures 120° and 100° :

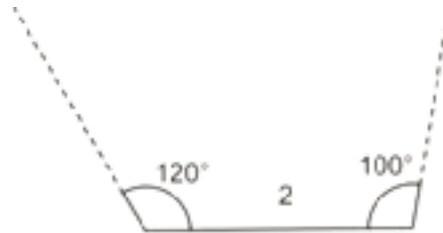

Sometimes, we are given two different angle measures and a side length between them, and we *can* draw a unique triangle. For example, if we draw a triangle with a side length of 4 between angles 90° and 60° , there is only one way they can meet up and complete to a triangle:

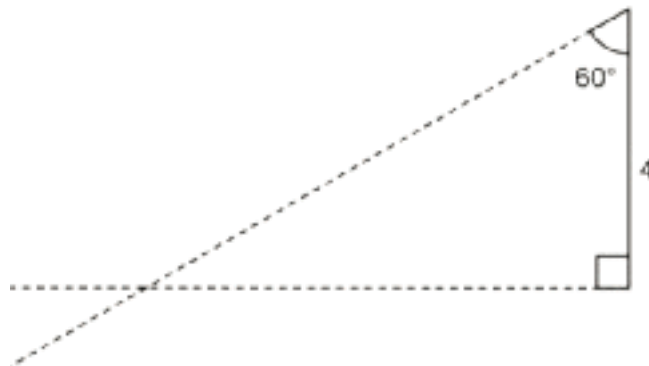



Any triangle drawn with these three conditions will be identical to the one above, with the same side lengths and same angle measures.

Lesson 9 Practice Problems

Problem 1

Statement

Use a protractor to try to draw each triangle. Which of these three triangles is impossible to draw?

- a. A triangle where one angle measures 20° and another angle measures 45°
- b. A triangle where one angle measures 120° and another angle measures 50°
- c. A triangle where one angle measures 90° and another angle measures 100°

Solution

It is impossible to draw a triangle where one angle measures 90° and another angle measures 100° .

Problem 2

Statement

A triangle has an angle measuring 90° , an angle measuring 20° , and a side that is 6 units long. The 6-unit side is in between the 90° and 20° angles.

- a. Sketch this triangle and label your sketch with the given measures.
- b. How many unique triangles can you draw like this?

Solution

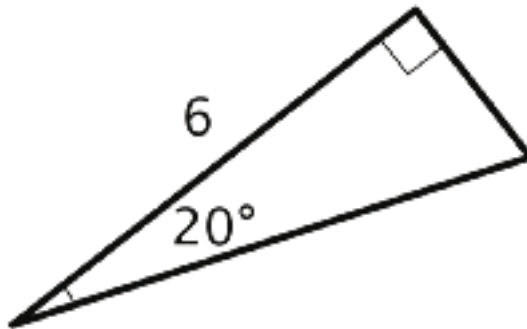

a.

- b. There is only one triangle that fits this description, so long as the 6-unit side is between the two given angles.

Problem 3

Statement

- Find a value for x that makes $-x$ less than $2x$.
- Find a value for x that makes $-x$ greater than $2x$.

Solution

Answers vary. Sample response:

- 1, because -1 is less than $2 \cdot 1$.
- -3 , because 3 is greater than $2 \cdot -3$.

(From Unit 5, Lesson 13.)

Problem 4

Statement

One of the particles in atoms is called an electron. It has a charge of -1 . Another particle in atoms is a proton. It has charge of $+1$.

The overall charge of an atom is the sum of the charges of the electrons and the protons. Here is a list of common elements.

| | charge from electrons | charge from protons | overall charge |
|-----------|-----------------------|---------------------|----------------|
| carbon | -6 | $+6$ | 0 |
| aluminum | -10 | $+13$ | |
| phosphide | -18 | $+15$ | |
| iodide | -54 | $+53$ | |
| tin | -50 | $+50$ | |

Find the overall charge for the rest of the atoms on the list.

Solution

Aluminum: $(-10) + (+13) = +3$

Phosphide: $(-18) + (+15) = -3$

Iodide: $(-54) + (+53) = -1$

Tin: $(-50) + (+50) = 0$

(From Unit 5, Lesson 3.)

Problem 5

Statement

A factory produces 3 bottles of sparkling water for every 7 bottles of plain water. If those are the only two products they produce, what percentage of their production is sparkling water? What percentage is plain?

Solution

30% of the production is sparkling water. 70% of the production is plain water.

(From Unit 4, Lesson 3.)

Lesson 10: Drawing Triangles (Part 2)

Goals

- Draw triangles with two given side lengths and one angle measure or three given angle measures, and describe (orally) how many different triangles could be drawn with the given conditions.
- Use drawings to justify (in writing) whether two given side lengths and one angle measure determine one unique triangle.

Learning Targets

- Given two side lengths and one angle measure, I can draw different triangles with these measurements or show that these measurements determine one unique triangle or no triangle.

Lesson Narrative

In this lesson, students continue their work from the previous lesson on drawing triangles with specified angle and side measures. Whereas in the previous lesson they focused on two angles and a side length, in this lesson they focus on two side lengths and an angle, and on three angles. They continue to gain experience with compass, ruler, and protractor. They continue to notice from their drawings when the conditions determine one triangle, more than one, or none. Students are not expected to know rules about which conditions determine each possibility.

Alignments

Addressing

- 7.G.A.2: Draw (freehand, with ruler and protractor, and with technology) geometric shapes with given conditions. Focus on constructing triangles from three measures of angles or sides, noticing when the conditions determine a unique triangle, more than one triangle, or no triangle.

Instructional Routines

- MLR1: Stronger and Clearer Each Time
- MLR5: Co-Craft Questions
- Think Pair Share

Required Materials

Compasses

Copies of Instructional master

Geometry toolkits

For grade 6: tracing paper, graph paper, colored pencils, scissors, and an index card to use as a straightedge or to mark right angles.

For grades 7 and 8: everything in grade 6, plus a ruler and protractor. Clear protractors with no

holes and with radial lines printed on them are recommended.

Notes: (1) "Tracing paper" is easiest to use when it's a smaller size. Commercially-available "patty paper" is 5 inches by 5 inches and ideal for this. If using larger sheets of tracing paper, consider cutting them down for student use. (2) When compasses are required in grades 6-8 they are listed as a separate Required Material.

Required Preparation

To help students see how they can use a compass to draw different triangles with two of the same side lengths, you might choose to copy the How Many Can You Draw? Instructional master for every student. This is optional.

Student Learning Goals

Let's draw some more triangles.

10.1 Using a Compass to Estimate Length

Warm Up: 5 minutes

The purpose of this warm-up is to remind students that a compass is useful for transferring a length in general, and not just for drawing circles. As students discuss answers with their partners, monitor for students who can clearly explain how they can use the compass to compare the length of the third side.

Addressing

- 7.G.A.2

Launch

Arrange students in groups of 2. Give students 2 minutes of quiet work time followed by time to discuss their answers with their partner. Follow with a whole-class discussion. Provide access to geometry toolkits and compasses.

Student Task Statement

1. Draw a 40° angle.
2. Use a compass to make sure both sides of your angle have a length of 5 centimeters.
3. If you connect the ends of the sides you drew to make a triangle, is the third side longer or shorter than 5 centimeters? How can you use a compass to explain your answer?

Student Response

1. and 2.

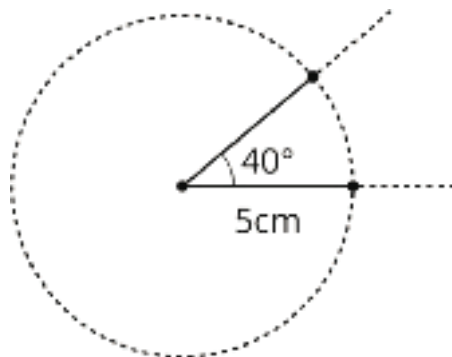

2. The third side is shorter than 5 cm. I know this because I can use my compass that is set to a radius of 5 cm and place it at the end of one of the two sides. When I draw another circle, the end of the other side of the angle is inside, so the distance between the two ends must be less than 5 cm.

Activity Synthesis

Ask previously identified students to share their responses to the final question. Display their drawing of the angle for all to see. If not mentioned in students' explanations, demonstrate for all to see how to use the compass to estimate the length of the third side of the triangle.

10.2 Revisiting How Many Can You Draw?

15 minutes (there is a digital version of this activity)

Students continue to practice drawing triangles from given conditions and categorizing their results. This activity focuses on the inclusion of a single angle and two sides. Again, they do not need to memorize which conditions result in unique triangles, but should begin to notice how some conditions (such as the equal side lengths) result in certain requirements for the completed triangle.

There is an optional Instructional master that can help students organize their work at trying different configurations of the first set of measurements. If you provide students with a copy of the Instructional master, ask them to determine whether any of the configurations result in the same triangle, as well as whether any one configuration results in two possible triangles.

Addressing

- 7.G.A.2

Instructional Routines

- MLR1: Stronger and Clearer Each Time
- MLR5: Co-Craft Questions

Launch

Keep students in same groups. Remind students of the activity in a previous lesson where they used the strips and fasteners to draw triangles on their paper. Ask what other tool also helps you find all the points that are a certain distance from a center point (a compass). Distribute optional Instructional masters if desired. Provide access to geometry toolkits and compasses.

Give students 7–8 minutes of partner work time, followed by a whole-class discussion.

If students have access to digital activities there is an applet that allows for triangle construction.

Access for English Language Learners

Reading, Speaking: MLR5 Co-craft Questions. Display just the statement: “One angle measures 40 degrees, one side measures 4 cm, and one side measures 5 cm.” Invite students to write down possible mathematical questions that could be asked with this information. Ask students to compare the questions generated with a partner before selecting 1–2 groups to share their questions with the class. Listen for the ways the given conditions are used or referenced in students’ questions. This routine will help students to understand the context of this problem before they are asked to create a drawing.

Design Principle(s): Maximize meta-awareness; Cultivate conversation

Anticipated Misconceptions

Some students may draw two different orientations of the same triangle for the first set of conditions, with the 40° angle in between the 4 cm and 5 cm sides. Prompt them to use tracing paper to check whether their two triangles are really different (not identical copies).

If students struggle to create more than one triangle from the first set of conditions, prompt them to write down the order they already used for their measurements and then brainstorm other possible orders they could use.

Student Task Statement

1. Draw as many different triangles as you can with each of these sets of measurements:
 - a. One angle measures 40° , one side measures 4 cm, and one side measures 5 cm.
 - b. Two sides measure 6 cm, and one angle measures 100° .
2. Did either of these sets of measurements determine one unique triangle? How do you know?

Student Response

1. Drawings vary. Sample responses:
 - a. There are 4 different triangles that can be drawn from the given conditions.

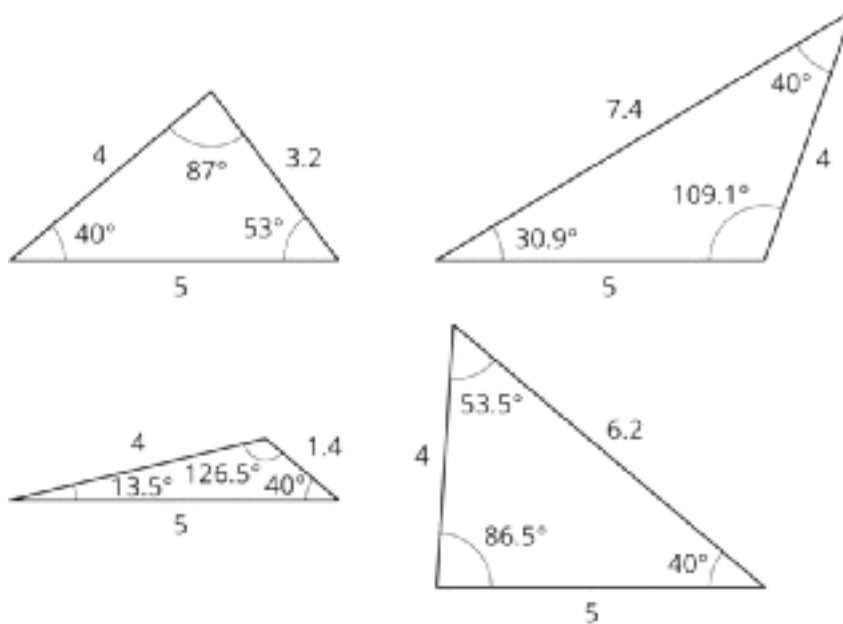

b. There is only one triangle that can be drawn from the given conditions.

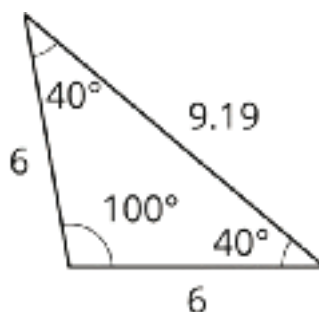

2. The second set of measurements determined one unique triangle. There was no other way I could draw it.

Activity Synthesis

Ask one or more students to share how many different triangles they were able to draw with each set of conditions. Select students to share their solutions.

If not brought up in student explanations, point out that for the first problem, one possible order for the measurements (40° , 5 cm, 4 cm) can result in two different triangles (the bottom two in the solution image). One way to show this is to draw a 5 cm segment and then use a compass to draw a circle with a 4 cm radius centered on the segment's left endpoint. Next, draw a ray at a 40° angle centered on the segment's right endpoint. Notice that this ray intersects the circle twice. Each one of these points could be the third vertex of the triangle. While it is helpful for students to notice this interesting aspect of their drawing, it is *not* important for students to learn rules about the number of possible triangles given different sets of conditions.

If the optional Instructional master was used, ask students:

- “Which configurations made identical triangles?” (the top left and bottom left)
- “Which configurations made more than one triangle?” (the bottom right)

If not mentioned by students, explain to students that the top left and bottom left configurations result in the same triangle, because in both cases the 40° angle is in between the 4 cm and 5 cm sides and that the bottom right configuration results in two different triangles, because the arc intersects the ray in two different places.

MLR 1 (Stronger and Clearer Each Time): Before discussing the second set of conditions as a whole class, have student pairs share their reasoning for why there were no more triangles that could be drawn with the given measures, with two different partners in a row. Have students practice using mathematical language to be as clear as possible when sharing with the class, when and if they are called upon.

Access for Students with Disabilities

Engagement: Develop Effort and Persistence. Break the class into small group discussion groups and then invite a representative from each group to report back to the whole class.

Supports accessibility for: Attention; Social-emotional skills

10.3 Three Angles

15 minutes (there is a digital version of this activity)

This activity focuses on including three angle conditions. The goal is for students to notice that some angle conditions result in a large number of possible triangles (all scaled copies of one another) or are impossible to create. Students are not expected to learn that the angles must sum to 180 degrees in a triangle, but are not barred from noticing this fact.

Addressing

- 7.G.A.2

Instructional Routines

- MLR1: Stronger and Clearer Each Time
- Think Pair Share

Launch

Arrange students in groups of 2. Tell students that they should attempt to create a triangle with the given specifications. If they can create one, they should attempt to either create at least one more or justify to themselves why there is only one. If they cannot create any, they should show some valid attempts to include as many pieces as they can and be ready to explain why they cannot include the remaining conditions.

Give students 5 minutes of quiet work time followed by time to discuss the triangles they could make with a partner. Follow with a whole-class discussion. Provide access to geometry toolkits and compasses.

If using the digital lesson, students should still try to create a triangle with the given specifications. If they can create one, they should attempt to either create at least one more or justify to themselves why there is only one. If they cannot create any, they should be ready to explain some of their attempts and why they cannot include the remaining conditions.

Anticipated Misconceptions

If students struggle to get started, remind them of Lin's technique of using the protractor and a ruler to make an angle that can move along a line.

Student Task Statement

1. Draw as many different triangles as you can with each of these sets of measurements:
 - a. One angle measures 50° , one measures 60° , and one measures 70° .
 - b. One angle measures 50° , one measures 60° , and one measures 100° .
2. Did either of these sets of measurements determine one unique triangle? How do you know?

Student Response

1.
 - a. Answers vary. Sample response:

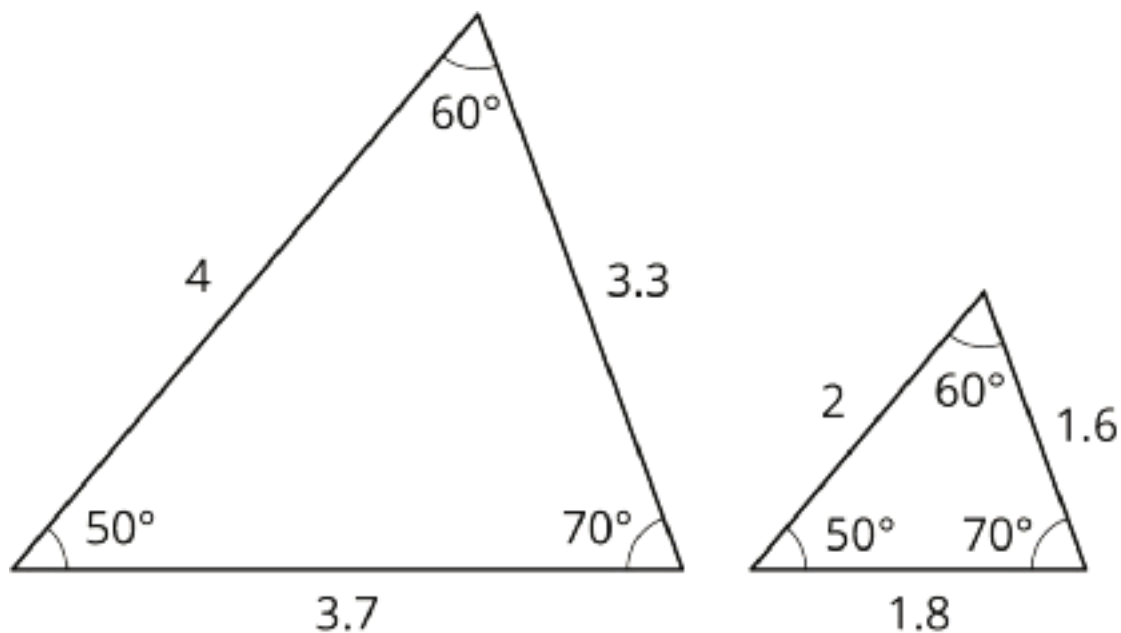

There are many possible triangles that can be made with these angle measurements, because we don't know any of the side lengths. All the possible triangles are scaled copies of each other.

b. There is no way to draw a triangle with these angle measurements, because once the first two angles are drawn, the third angle is already set.

■ If I start with 50° and 60° , then the third angle is always 70° . I can't make it 100° .

■ If I start with 50° and 100° , then the third angle is always 30° . I can't make it 60° .

■ If I start with 60° and 100° , then the third angle is always 20° . I can't make it 50° .

2. Neither of these sets of measurements determine 1 unique triangle.

Are You Ready for More?

Using *only* a compass and the edge of a blank index card, draw a perfectly equilateral triangle. (Note! The tools are part of the challenge! You may not use a protractor! You may not use a ruler!)

Student Response

Draw a line segment and label the endpoints A and B . Open compass so that the radius is the same length as the line segment you drew. Place pointy end of ruler on A , swing arc. Put pointy end on B , swing arc. Intersection of arcs is the other vertex of the equilateral triangle.

Activity Synthesis

Select students to share their drawings and display them for all to see. Ask students:

- "Were there any sets of measurements that produced a unique triangle?" (no)
- "Which combinations of angles could not be drawn?" (the angles in the second problem, 50° , 60° , 100°)
- "Why is there more than one triangle that can be made with the measurements in the first problem?" (because there are no side lengths mentioned, so we can create scaled copies of the triangles with the same angles but with shorter or longer side lengths)

MLR 1 (Stronger and Clearer Each Time): Before discussing the second set of conditions as a whole class, have student pairs share their reasoning for why there were no triangles that could be drawn with the given measures, with two different partners in a row. Have students practice using mathematical language to be as clear as possible when sharing with the class, when and if they are called upon.

Lesson Synthesis

- How was a compass useful in drawing triangles today? (It helps find all the points a certain distance away.)

- What strategies did you use to include two given side lengths and a given angle? (Draw one of the side lengths and use a protractor to draw the angle at one end, then use a compass to finish the picture.)
- What strategies did you use to include three given angles? (Draw one angle then use a protractor and ruler to slide along one side of the first angle.)

10.4 Finishing Noah's Triangle

Cool Down: 5 minutes

Addressing

- 7.G.A.2

Student Task Statement

Noah is trying to draw a triangle with a 30° angle and side lengths of 4 cm and 6 cm.

- He uses his ruler to draw a 4 cm line segment.
- He uses his protractor to draw a 30° angle on one end of the line segment.

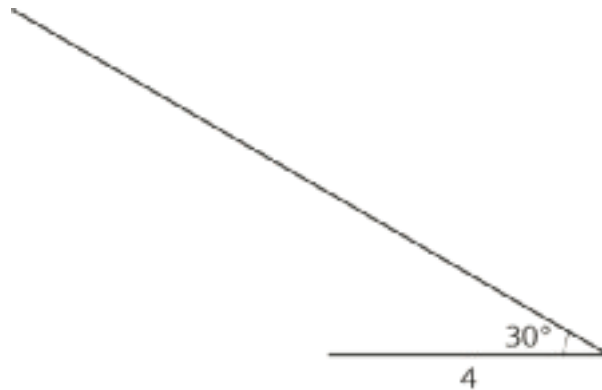

1. What should Noah do next? Explain and show how he can finish drawing the triangle.
2. Is there a different triangle Noah could draw that would answer the question? Explain or show your reasoning.

Student Response

1. Noah should use a compass to draw a circle with radius 6 cm and center at one end of the 4 cm side. He should then draw segments connecting both ends of the 4 cm side to the point where the circle and ray cross to complete the triangle.
2. Yes. Noah could try beginning with the same setup he has already drawn again, but this time center the circle on the other end of the 4 cm side. He could also start with the 6 cm side drawn instead of the 4 cm side and follow the same process.

Student Lesson Summary

A triangle has six measures: three side lengths and three angle measures.

If we are given three measures, then sometimes, there is no triangle that can be made. For example, there is no triangle with side lengths 1, 2, 5, and there is no triangle with all three angles measuring 150° .

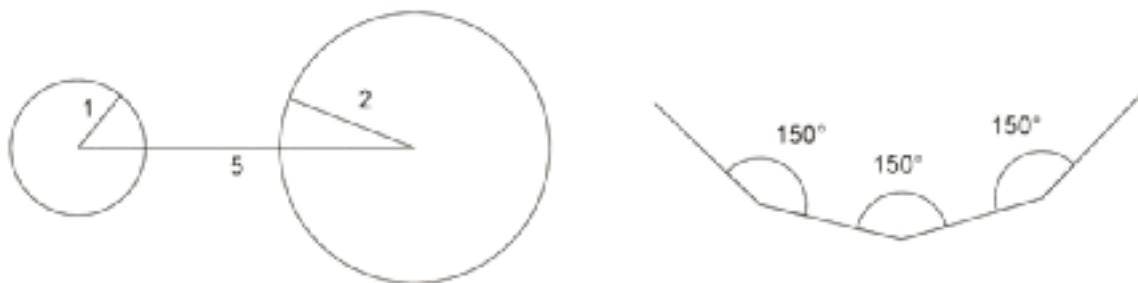

Sometimes, only one triangle can be made. By this we mean that any triangle we make will be the same, having the same six measures. For example, if a triangle can be made with three given side lengths, then the corresponding angles will have the same measures. Another example is shown here: an angle measuring 45° between two side lengths of 6 and 8 units. With this information, one unique triangle can be made.

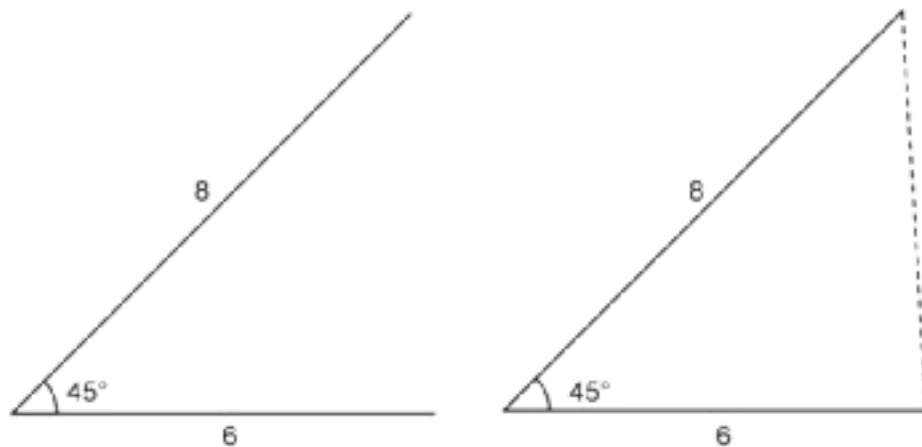

Sometimes, two or more different triangles can be made with three given measures. For example, here are two different triangles that can be made with an angle measuring 45° and side lengths 6 and 8. Notice the angle is not between the given sides.

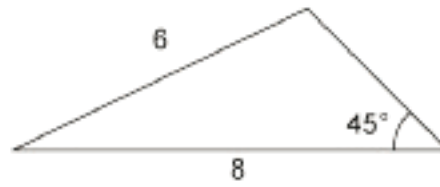
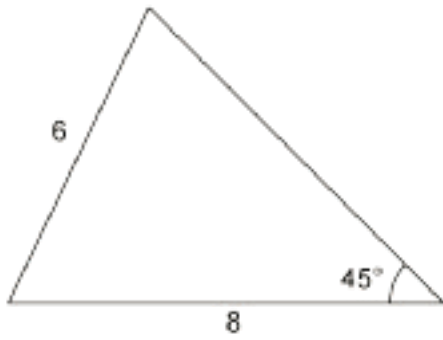

Three pieces of information about a triangle's side lengths and angle measures may determine no triangles, one unique triangle, or more than one triangle. It depends on the information.

Lesson 10 Practice Problems

Problem 1

Statement

A triangle has sides of length 7 cm, 4 cm, and 5 cm. How many unique triangles can be drawn that fit that description? Explain or show your reasoning.

Solution

You can only draw one unique triangle with those same 3 measures. If you start by drawing the 7 cm side and then draw circles of radii 4 cm and 5 cm at each endpoint, the circles will cross at two places. Connecting the endpoints of the 7 cm side to those crossing points will produce two identical triangles, each having side lengths 7 cm, 4 cm, and 5 cm. There are no other points that could be the third vertex of the triangle.

Problem 2

Statement

A triangle has one side that is 5 units long and an adjacent angle that measures 25° . The two other angles in the triangle measure 90° and 65° . Complete the two diagrams to create two *different* triangles with these measurements.

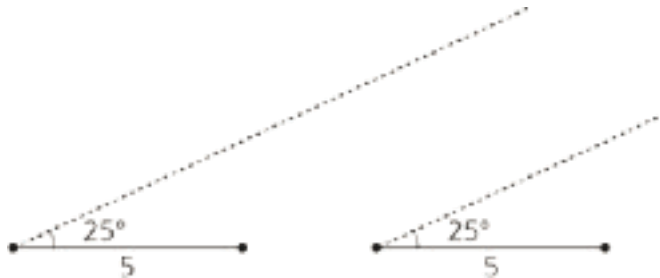

Solution

Answers vary.

Problem 3

Statement

Is it possible to make a triangle that has angles measuring 90 degrees, 30 degrees, and 100 degrees? If so, draw an example. If not, explain your reasoning.

Solution

No, if you try to draw a triangle that has a 90 degree angle on the end of a side and a 100 degree angle on the other end of the same side, there is no way to make the other two sides meet to form a triangle.

Problem 4

Statement

Segments CD , AB , and FG intersect at point E . Angle FEC is a right angle. Identify any pairs of angles that are complementary.

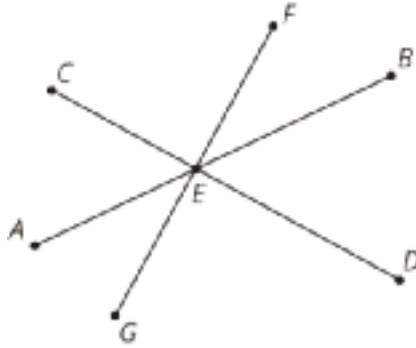

Solution

- FEB and DEB
- CEA and AEG

These are also complementary, but students may not have the tools to identify them yet:

- FEB and CEA
- DEB and AEG

(From Unit 7, Lesson 2.)

Problem 5

Statement

Match each equation to a step that will help solve the equation for x .

A. $3x = -4$

B. $-4.5 = x - 3$

C. $3 = \frac{-x}{3}$

D. $\frac{1}{3} = -3x$

E. $x - \frac{1}{3} = 0.4$

F. $3 + x = 8$

G. $\frac{x}{3} = 15$

H. $7 = \frac{1}{3} + x$

1. Add $\frac{1}{3}$ to each side.

2. Add $\frac{-1}{3}$ to each side.

3. Add 3 to each side.

4. Add -3 to each side.

5. Multiply each side by 3..

6. Multiply each side by -3.

7. Multiply each side by $\frac{1}{3}$.

8. Multiply each side by $\frac{-1}{3}$.

Solution

- A: 7
- B: 3
- C: 6
- D: 8
- E: 1
- F: 4
- G: 5
- H: 2

(From Unit 5, Lesson 15.)

Problem 6

Statement

- a. If you deposit \$300 in an account with a 6% interest rate, how much will be in your account after 1 year?
- b. If you leave this money in the account, how much will be in your account after 2 years?

Solution

- a. \$318
- b. \$337.08

(From Unit 4, Lesson 8.)

Section: Solid Geometry

Lesson 11: Slicing Solids

Goals

- Categorize images of planes intersecting pyramids and prisms, and describe (orally) the categories.
- Comprehend that the term “cross section” (in spoken and written language) refers to the two-dimensional face that results from slicing a three-dimensional figure.
- Describe, compare, and contrast (orally and in writing) different cross sections that could result from slicing the same pyramid or prism.

Learning Targets

- I can explain that when a three dimensional figure is sliced it creates a face that is two dimensional.
- I can picture different cross sections of prisms and pyramids.

Lesson Narrative

This lesson introduces the idea that slicing a three-dimensional figure with a plane results in a two-dimensional cross section. Slicing a fruit or vegetable, dipping the exposed face in paint, and stamping it on a paper helps students focus on the two-dimensional face that is created by the slice. Given two-dimensional representations of how objects are sliced, students practice visualizing the three-dimensional figures and the resulting cross sections.

Alignments

Addressing

- 7.G.A.3: Describe the two-dimensional figures that result from slicing three-dimensional figures, as in plane sections of right rectangular prisms and right rectangular pyramids.

Building Towards

- 7.G.B.6: Solve real-world and mathematical problems involving area, volume and surface area of two- and three-dimensional objects composed of triangles, quadrilaterals, polygons, cubes, and right prisms.

Instructional Routines

- MLR2: Collect and Display
- MLR7: Compare and Connect
- MLR8: Discussion Supports

Required Materials

Fruits or vegetables
Knife
Paint

Pre-printed cards, cut from copies of the
Instructional master

Required Preparation

As part of the lesson, the teacher will slice a fruit or vegetable to show a cross section. Recommended are apples, potatoes, or carrots. Tempera or acrylic paint can also be used to stamp the cross section onto paper.

You will need the Cross Section Card Sort Instructional master for this lesson. Prepare 1 copy per 3 students, cut the slips, and put each set in an envelope. These slips can be reused from one class to the next. If possible, copy each complete set of cards on a different color of paper, so that a stray card can quickly be put back.

Student Learning Goals

Let's see what shapes you get when you slice a three-dimensional object.

11.1 Prisms, Pyramids, and Polyhedra

Warm Up: 5 minutes (there is a digital version of this activity)

The purpose of this warm-up is to review important characteristics of prisms, pyramids, and polyhedra. Students should be able to interpret the two-dimensional pictures and three-dimensional objects, understanding that the dotted lines indicate hidden lines and identify all of the parts of the polyhedra.

Building Towards

- 7.G.B.6

Launch

Ask students, "What do you see? Describe the object and its parts as precisely as you can." Give students 2 minutes of quiet work time followed by a whole-class discussion.

If students have access to digital activities, there is an applet for them to explore while answering the question.

Anticipated Misconceptions

Students may think that a pyramid must have its apex over the center of the base. Students may think that a prism (or pyramid) must have base at the "bottom".

Student Task Statement

Describe each shape as precisely as you can.

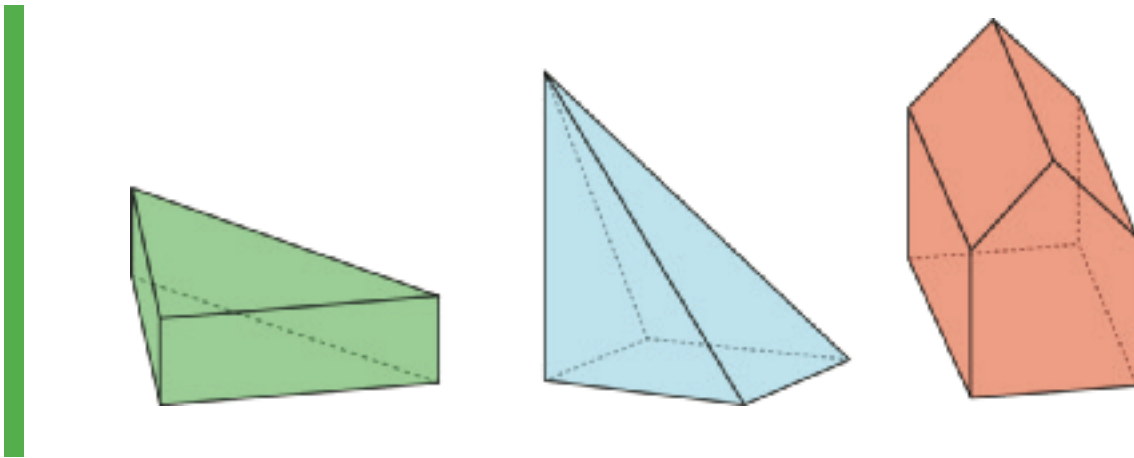

Student Response

The first image is a triangular prism with a base that is a right triangle.

The second image is a rectangular pyramid with a vertex that is not centered over the base.

The third image is a prism with a base that is a pentagon.

Activity Synthesis

Ask students to describe each shape. Record and display their responses for all to see. After each student shares, ask the group if they have anything to add before moving on to the next shape.

If not mentioned by students, explain:

- A prism is a polyhedron with two identical polygon bases, connected by rectangles.
- A pyramid is a polyhedron with one polygon base, and all other faces are triangles meeting at a point.

11.2 What's the Cross Section?

10 minutes (there is a digital version of this activity)

The goal of this activity is to help visualize cross sections of a three-dimensional object. One way to do this is to cut a solid object and use one or both of the pieces to stamp the resulting cross section onto paper. This helps students see the two-dimensional shape that results from cutting a three-dimensional object. During the launch of this activity, students see a demonstration of cutting a fruit or vegetable and are asked to describe the shape of the cross section. Students are then asked to describe the shape of a cross section of a three-dimensional object given to them in the task statement.

As students work on the task, monitor for students who can describe the two-dimensional shape produced from each cross section described.

Addressing

- 7.G.A.3

Instructional Routines

- MLR2: Collect and Display

Launch

Cut the fruit or vegetable so that the cut is in a plane. Some choices: cut an apple vertically, through the stem. (The cross section will be somewhat heart-shaped, with an indentation.) Cut any through the “equator” (The cross section will be a circle.) Carrot or long potato, cut diagonally (The cross section will be an ellipse, oval, or stretched circle.) Before showing students the cut surface, ask students what shape they think the surface is. Then dip the surface into the paint and stamp on a piece of paper. Then put the cut vegetable back together so that both sides of the cut are painted. Show that the resulting pieces each have a cut surface, and the two surfaces are identical.

Display the paper with the painted cross section for all to see. Invite students to describe the shape of the cross section. Tell students that in this activity they are going to have to describe the shape of something after a cut is made. Give students 2–3 minutes of quiet work time followed by time to discuss the shapes with their partner. Follow with a whole-class discussion.

If students *do not* have access to the digital version of the activity, consider projecting the applet and demonstrating for all to see (if possible).

Access for Students with Disabilities

Representation: Develop Language and Symbols. Use virtual or concrete manipulatives to connect symbols to concrete objects or values. Provide students with a printed copy of the student task statement to draw on or annotate.

Supports accessibility for: Conceptual processing

Access for English Language Learners

Speaking: MLR2 Collect and Display. As groups discuss, circulate and listen to student talk about the shapes formed when the solids are sliced. Capture student language that reflects a variety of ways students are making sense of the shapes, such as “both cross sections are rectangles” or “the rectangles are not of the same size”. Display the collected language visually for the whole class to use as a reference in further discussions in the lesson and unit. Ask students to suggest revisions, updates, and connections to the display as they develop new mathematical ideas and ways of communicating. This will help students increase awareness of use of mathematical language as they progress through the unit.

Design Principle(s): Support sense-making; Maximize meta-awareness

Anticipated Misconceptions

Some students may struggle to visualize slicing the solids that are shown. It may be helpful to use a three-dimensional model of the rectangular prism and rectangular pyramid to demonstrate where the cut is happening in each question. Building the solids out of salt dough and slicing them with dental floss is another option.

Student Task Statement

Here is a rectangular prism and a pyramid with the same base and same height.

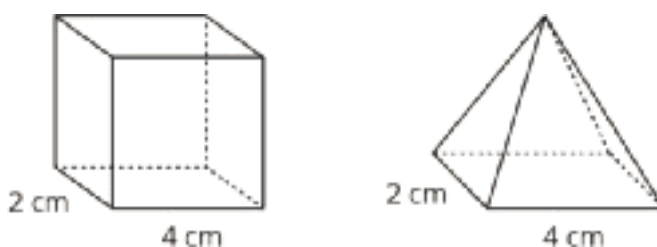

1. Think about slicing each solid parallel to its **base**, halfway up. What shape would each **cross section** be? What is the same about the two cross sections? What is different?
2. Think about slicing each solid parallel to its base, near the top. What shape would each cross section be? What is the same about the two cross sections? What is different?

Student Response

1. Both objects have a cross section in the shape of a rectangle. The difference is that the rectangle on the prism is the same size as the base, but the rectangle on the pyramid is smaller.
2. Again, both objects have a cross section in the shape of a rectangle. The rectangle on the prism is still the same size as the base, but the rectangle on the pyramid is much smaller.

Are You Ready for More?

Describe the cross sections that would result from slicing each solid perpendicular to its base.

Student Response

Slicing the rectangular prism perpendicular to its base will always result in a rectangular cross section, regardless of the location of the slice.

Slicing the rectangular pyramid perpendicular to its base could result in a cross section in the shape of a triangle or a trapezoid, depending on the location of the slice.

Activity Synthesis

Select previously identified students to describe the shapes of cross sections of the objects. Consider asking some of the following questions:

- “How do the cross sections in the different objects compare to one another?” (One is a scaled copy of the other.)

- “How do the cross sections in each object compare to its own base?” (In the cube, the cross section is the same as the base, in the pyramid, the cross section is a scaled copy of the base.)

Explain to students that in the next activity they will get another chance to determine shapes of different cross sections.

11.3 Card Sort: Cross Sections

10 minutes

In this activity, students practice visualizing cross sections in a more abstract way by looking at images of a solid object that has been cut by a plane and matching those images to the shapes created by the cuts. The cuts made in this activity vary from the previous activity in that the cuts are not all parallel to the base of the three-dimensional object.

As students work on the task, monitor for groups of students who use different reasons to sort their cards.

Addressing

- 7.G.A.3

Instructional Routines

- MLR7: Compare and Connect

Launch

Arrange students into groups of 3. Supply each group with cards cut from the Instructional master. Tell students that these cards have different things in common so different groups of students might have different reasons for grouping certain images together. Give students 2–3 minutes of quiet work time followed by a whole-class discussion.

Access for Students with Disabilities

Engagement: Develop Effort and Persistence. Encourage and support opportunities for peer interactions. Invite students to talk about their ideas with a partner before writing them down. Display sentence frames to support students when they explain their strategy. For example, “Both ___ and ___ are alike because . . .”, ___ and ___ are different because . . .”

Supports accessibility for: Language; Social-emotional skills

Student Task Statement

Your teacher will give you a set of cards. Sort the images into groups that make sense to you. Be prepared to explain your reasoning.

Student Response

Answers vary. Sample groupings:

- Cross section is parallel to the base (4 cards), cross section is perpendicular to the base (3 cards), and cross section is oblique to the base (6 cards)
- Cross section is a triangle (5 cards), and cross section is a quadrilateral (8 cards)
- Figure is a rectangular prism (3 cards), figure is a triangle-based pyramid (4 cards), figure is a square-based pyramid (3 cards), and figure is a triangular prism (3 cards)

Activity Synthesis

Select previously identified groups to share their groupings and reasons for grouping them that way.

If not mentioned by students, explain that there are a few ways to sort the cards:

- Based on the solid object that is being cut. (rectangular prism, triangular prism, square-based pyramid, triangle based pyramid)
- Based on the cross section made by the cuts. (parallel to the base, perpendicular to the base, oblique to the base)
- Based on the shape of cross section. Note that there could be two or three groups for these cards: triangles, and quadrilaterals or triangles, rectangles, and trapezoids.

Explain to students that it is possible to create other cross section shapes by cutting these objects in other ways.

Access for English Language Learners

Listening, Speaking, Conversing: MLR7 Compare and Connect. After students have sorted the images into groups that make sense to them, ask students to investigate each other's work by taking a tour of their visual displays. Facilitate discussion among students by asking questions such as, "What similarities or differences do you see in other groups' sorting as compared to your sorting?" or "What worked well while sorting the images?" Guide students to make connections between specific features of the images, such as the shape of a cross section and the cross section made by the cuts. This will help foster students' meta-awareness of the language as they compare or contrast the sorting of images.

Design Principle(s): Cultivate conversation; Maximize meta-awareness

11.4 Drawing Cross Sections

Optional: 20 minutes (there is a digital version of this activity)

In this activity, students are given pictures and descriptions of planes cutting prisms and pyramids. Students are asked to draw cross sections freehand but this is not a skill that is required in order for students to be able to describe two-dimensional shapes created from cross sections, which is

why this is an optional activity. Some pictures are of a moving plane. Students describe how the cross section changes as the plane moves.

If students have access to the digital activity there are applets to explore the cross sections.

Adapted from applets created in GeoGebra by [Anthony C.M. OR.](#)

Addressing

- 7.G.A.3

Instructional Routines

- MLR8: Discussion Supports

Launch

Arrange students in groups of 2. Give students 3–5 minutes of quiet work time followed by time to discuss shapes of cross sections with a partner. Follow with a whole-class discussion.

Student Task Statement

Draw and describe each cross section.

1. Here is a picture of a rectangular prism, 4 units by 2 units by 3 units.

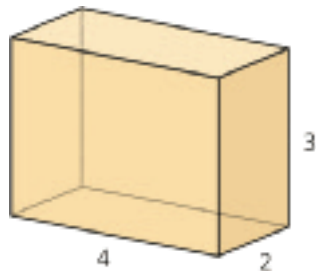

- a. A plane cuts the prism parallel to the bottom and top faces.

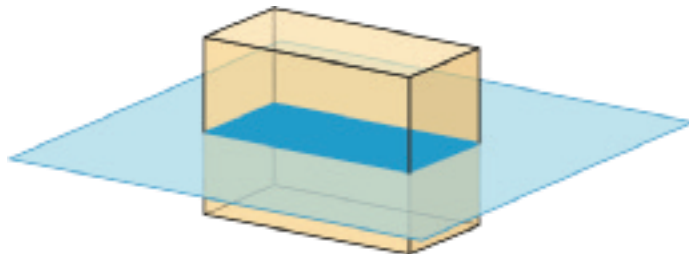

- b. The plane moves up and cuts the prism at a different height.

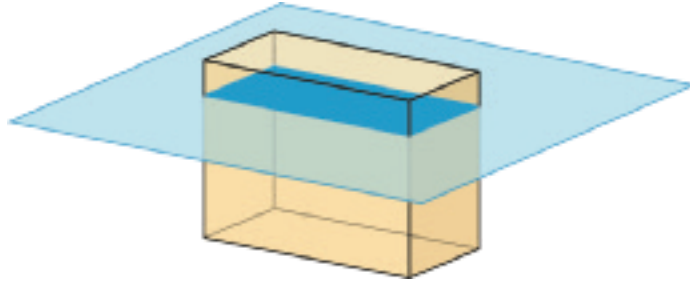

c. A vertical plane cuts the prism diagonally.

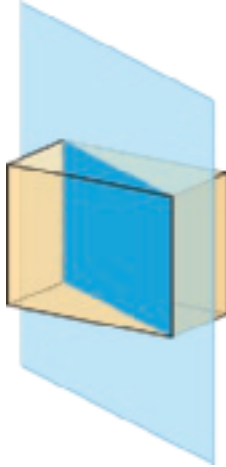

2. A square pyramid has a base that is 4 units by 4 units. Its height is also 4 units.

a. A plane cuts the pyramid parallel to the base.

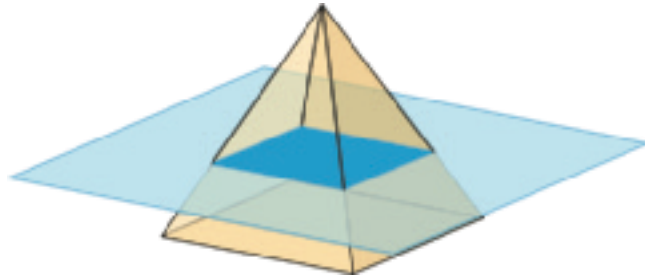

b. A vertical plane cuts the prism.



3. A cube has an edge of length 4.

a. A plane cuts off the corner of the cube.

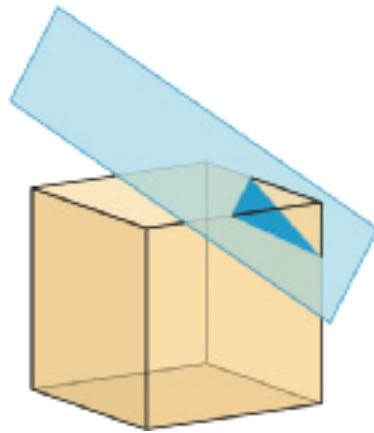

b. The plane moves farther from the corner and makes a cut through the middle of the cube.

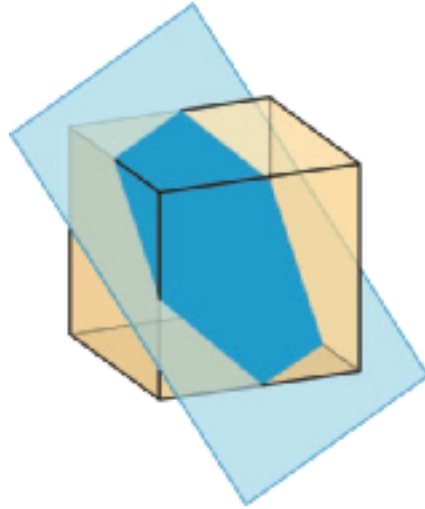

Student Response

Drawings of:

1.
 - a. A rectangle with length 4 and width 2.
 - b. A rectangle with length 4 and width 2.
 - c. A rectangle with height 3 and width the length of the diagonal of the base.
2.
 - a. A square with width and length less than 4.
 - b. An isosceles triangle with base 4 and height 4.
3.
 - a. A triangle.
 - b. A hexagon.

Activity Synthesis

Select students to share their drawings and descriptions. Consider asking some of the following questions:

- “How did you figure out the shape of the cross section?”
- “What helped you visualize the shape?”
- “Were any of the shapes you drew here similar to the shapes you described in the previous activity?”

Access for English Language Learners

Conversing: MLR8: Discussion Supports. To support a rich discussion while students are describing two-dimensional shapes created from cross sections, invite students to include details in their descriptions and drawings of each cross section. Provide sentence frames such as: “The cross section is ___ because . . .”, “A plane cuts ___ as shown by . . .”, or “The dimensions of a cross section are ___ since . . .” This will help students make sense of complex language as they draw and describe cross sections shown in each figure.

Design Principle(s): Cultivate conversation

Lesson Synthesis

- “What is a cross section?” (It is a two-dimensional shape that results from slicing a three-dimensional object.)
- “What are the possible cross sections that can result from a prism that is sliced parallel to its base?” (All cross sections will be the same size and shape as the base.)
- “Can cross sections of a prism or pyramid be a different shape than the base? Explain or give an example.” (Yes, they can be different. For example, slicing off the corner of a cube can result in a triangle.)

11.5 Pentagonal Pyramid

Cool Down: 5 minutes

Addressing

- 7.G.A.3

Student Task Statement

Here is a pyramid with a base that is a pentagon with all sides the same length.

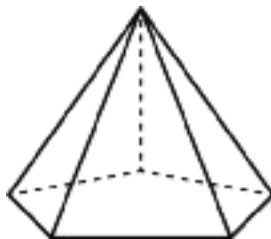

1. Describe the cross section that will result if the pyramid is sliced:
 - a. horizontally (parallel to the base).
 - b. vertically through the top vertex (perpendicular to the base).

2. Describe another way you could slice the pyramid that would result in a different cross section.

Student Response

1. Cross sections:
 - a. A pentagon with all sides the same length, but smaller than the base of the pyramid
 - b. A triangle
2. Answers vary. Sample responses:
 - a. You could slice the pyramid diagonally.
 - b. You could slice the pyramid vertically but not through the top vertex.

Student Lesson Summary

When we slice a three-dimensional object, we expose new faces that are two dimensional. The two-dimensional face is a **cross section**. Many different cross sections are possible when slicing the same three-dimensional object.

Here are two peppers. One is sliced horizontally, and the other is sliced vertically, producing different cross sections.



The imprints of the slices represent the two-dimensional faces created by each slice.

It takes practice imagining what the cross section of a three-dimensional object will be for different slices. It helps to experiment and see for yourself what happens!

Glossary

- base (of a prism or pyramid)
- cross section
- prism
- pyramid

Lesson 11 Practice Problems

Problem 1

Statement

A cube is cut into two pieces by a single slice that passes through points A , B , and C . What shape is the cross section?

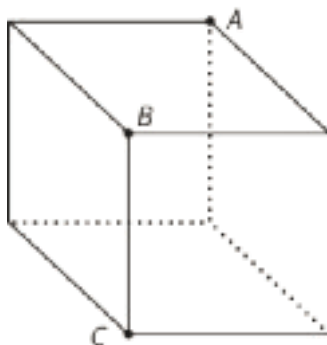

Solution

Rectangle

Problem 2

Statement

Describe how to slice the three-dimensional figure to result in each cross section.

Three-dimensional figure:



Cross sections:



Solution

To get a cross section that is a triangle, make a slice that is parallel to one of the pyramid's faces. To get a cross section that is a trapezoid, make a slice that is perpendicular to one of the pyramid's faces that does not pass through the pyramid's opposite vertex.

Problem 3

Statement

Here are two three-dimensional figures.

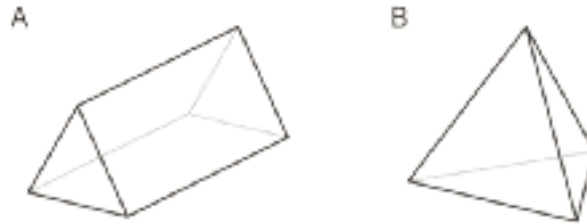

Describe a way to slice one of the figures so that the cross section is a rectangle.

Solution

If you slice figure A perpendicular to its triangular bases, the cross section is a rectangle.

Problem 4

Statement

Each row contains the degree measures of two supplementary angles. Complete the table.

| measure of an angle | measure of its supplement |
|---------------------|---------------------------|
| 80° | |
| 25° | |
| 119° | |
| x | |

Solution

| measure of an angle | measure of its supplement |
|---------------------|---------------------------|
| 80° | 100° |
| 25° | 155° |
| 119° | 61° |
| x | $180 - x$ |

(From Unit 7, Lesson 2.)

Problem 5

Statement

Two months ago, the price, in dollars, of a cell phone was c .

- Last month, the price of the phone increased by 10%. Write an expression for the price of the phone last month.
- This month, the price of the phone decreased by 10%. Write an expression for the price of the phone this month.
- Is the price of the phone this month the same as it was two months ago? Explain your reasoning.

Solution

- $1.1c$ or equivalent (Because 10% of c is $0.1c$ and, adding this to c , gives $1.1c$)
- $0.99c$ or equivalent (Because 10% of $1.1c$ is $0.11c$ and this gives $0.99c$ when subtracted from $1.1c$)
- No, the phone is a little bit cheaper now than it was a month ago. The 10% discount this month is on the higher price so it is more than the 10% increase a month ago.

(From Unit 4, Lesson 8.)

Lesson 12: Volume of Right Prisms

Goals

- Determine the volume of a right prism by counting how many unit cubes it takes to build one layer and then multiplying by the number of layers.
- Generalize (orally) the relationship between the volume of a prism, the area of its base, and its height.
- Identify whether a given figure is a prism, and if so, identify its base and height.

Learning Targets

- I can explain why the volume of a prism can be found by multiplying the area of the base and the height of the prism.

Lesson Narrative

In grades 5 and 6, students calculated the volume of rectangular prisms. In this lesson, students learn that they can calculate the volume of any right prism by multiplying the area of the base times the height of the prism. Students make sense of this formula by picturing the prism decomposed into identical layers 1 unit tall. These layers are composed of a number of cubic units equal to the number of square units in the area of the base. The height of the prism tells how many of these layers there are. Therefore, multiplying the number of cubic units in one layer times the number of layers gives the total number of cubic units in the prism, regardless of the shape of the base.

Given some three-dimensional figures that are prisms and some that are not, students decide whether they can apply the formula $V = Bh$ to calculate the volume. If so, they identify the base and measure the height, before calculating the volume. Students also apply the formula $V = Bh$ to find the height of a prism given its volume and the area of its base.

Alignments

Addressing

- 7.G.B.6: Solve real-world and mathematical problems involving area, volume and surface area of two- and three-dimensional objects composed of triangles, quadrilaterals, polygons, cubes, and right prisms.

Instructional Routines

- MLR1: Stronger and Clearer Each Time
- MLR3: Clarify, Critique, Correct
- MLR8: Discussion Supports

Required Materials

Copies of Instructional master
Pre-assembled polyhedra

Rulers marked with centimeters
Snap cubes

Required Preparation

You will need the Finding Volume with Cubes Instructional master for this lesson. You will only use one of the two pages. If your snap cubes measure $\frac{3}{4}$ inch, print the first page of the Instructional master, with the slightly smaller shapes. If your snap cubes measure 2 cm, print the second page of the Instructional master, with the slightly larger shapes. Make sure to print the Instructional master at 100% scale so the dimensions are accurate. Prepare 1 copy for every 6 students, and cut the pages in half so that each group of 3 students has one half-page.

Print, cut, and assemble the nets from the Can You Find the Volume? Instructional master. Card stock paper is recommended. Make sure to print the Instructional master at 100% scale so the dimensions are accurate. Prepare 1 polyhedron for every 2 students (1 copy of the entire file for every 12--18 students).

Make sure students have access to snap cubes and rulers marked in centimeters.

Student Learning Goals

Let's look at volumes of prisms.

12.1 Three Prisms with the Same Volume

Warm Up: 5 minutes

The purpose of this warm-up is to encourage students to think about possible heights of prisms with the same height and volume based on the area of a base. This is a review of previous work students have done with volume in which they found the volume of a rectangular prism by multiplying the area of a base and height. The ideas in this warm-up are revisited later in this lesson, so it is important students can clearly explain how they ordered their prisms based on them having the same volume and how they found the height of the prism with base C.

Addressing

- 7.G.B.6

Launch

Arrange students in groups of 2. Give students 1 minute of quiet work time followed by time to discuss their explanations with a partner. Follow with a whole-class discussion.

Student Task Statement

Rectangles A, B, and C represent bases of three prisms.

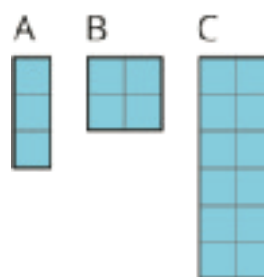

1. If each prism has the same height, which one will have the greatest **volume**, and which will have the least? Explain your reasoning.
2. If each prism has the same volume, which one will have the tallest height, and which will have the shortest? Explain your reasoning.

Student Response

1. Prism C will have the greatest volume and prism A will have the least. Since the volume is the area of the base multiplied by the height the base with the greatest area will have the greatest volume, even if all the heights are the same.
2. Prism A will have the tallest height and prism C will have the shortest. Since the volume is the area of the base multiplied by the height, the base with the smallest area will have the tallest height and the base with the greatest area will have the shortest height.

Activity Synthesis

Select students to share the prism they found to have the greatest and least volume and the tallest and shortest height. Record and display their responses for all to see. Poll the class if they agree or disagree. If students all agree, ask a few students to share their reasoning. If they do not agree, ask students to share their reasoning until they reach an agreement.

If there is time, display this question for all to see: "If each prism has the same volume and the prism associated with base B has a height of 6 units, what is the height of the prism associated with base C?"

Have students share the volume of the prism with base C and their reasoning. Record and display the responses for all to see.

12.2 Finding Volume with Cubes

10 minutes (there is a digital version of this activity)

In grades 5 and 6, students worked with the volume of rectangular prisms. In this activity, students extend their understanding to see that even when the base is not a rectangle, they can still calculate the volume of a prism by multiplying the area of the base times the height of the prism.

Students use snap cubes to build a prism with a base that matches the shape from the Instructional master. Each group needs 30 snap cubes for the first question and a total of 60 snap cubes for the second question. If there are not enough snap cubes, two groups of 3 students may combine together after answering the first question to form one group of 6 students.

If using snap cubes that measure $\frac{3}{4}$ inch, make copies of the first page of the Instructional master, with the slightly smaller shapes. If using snap cubes that measure 2 cm, make copies of the second page of the Instructional master, with the slightly larger shapes.

Addressing

- 7.G.B.6

Instructional Routines

- MLR1: Stronger and Clearer Each Time

Launch

Arrange students in groups of 3. Distribute copies of the Instructional master, one half-page to each group, and 30–60 snap cubes to each group. Give students 2–3 minutes of quiet work time followed by a whole-class discussion.

For students using digital materials: depending on the needs of your class, either demonstrate how to build figures using the applet, or instruct students to read and follow the instructions for working the applet.

Student Task Statement

Your teacher will give you a paper with a shape on it and some snap cubes.

1. Using the face of a snap cube as your area unit, what is the area of the shape? Explain or show your reasoning.
2. Use snap cubes to build the shape from the paper. Add another layer of cubes on top of the shape you have built. Describe this three-dimensional object.
3. What is the volume of your object? Explain your reasoning.
4. Right now, your object has a height of 2. What would the volume be:
 - a. if it had a height of 5?
 - b. if it had a height of 8.5?

Student Response

1. 27 units². Possible strategy: $3 \cdot 3 + 3 \cdot 6 = 27$.
2. Answers vary. Sample response: It is a prism with a base in the shape of an “L.”

3. 54 units^3 , because $2 \cdot 27 = 54$.
4.
 - a. 135 units^3 , because it would take 5 layers and $5 \cdot 27 = 135$.
 - b. 229.5 units^3 , because $8.5 \cdot 27 = 229.5$.

Activity Synthesis

Select students to share their reasoning.

Consider asking some of the following questions:

- “How do you know this figure is a prism?” (Cross sections parallel to the base are identical copies.)
- “What is the area of the base of this figure?” (It is the number of cubes in one layer of the prism.)
- “How do you calculate the total number of cubes to make the prism?” (Multiply the number of cubes in one layer by the number of layers.)
- “What is the volume of this prism?” (The volume is the same as calculating the number of cubes to make the prism.)
- “If you find the area of the base, how do you use that information to calculate the volume of the prism?” (Multiply the area of the base by the height of the prism.)
- “How would the volume of the prism change if we changed the shape of the base but still used 27 cubes to build it?” (The volume would not change.)

If not mentioned by students, explain that calculating the total number of cubes to make the prism is the same as calculating the volume of the prism. We can find the area of the base of the prism and multiply that by the number of layers in the prism which is the same as the height of the prism.

The height of the prism is measured in units, the area of the base is measured in units^2 and the volume of the prism is measured in units^3 .

Access for English Language Learners

Writing, Listening, Conversing: MLR1 Stronger and Clearer Each Time. Use this routine to help students improve their writing, by providing them with multiple opportunities to clarify their explanations through conversation. Invite students to draft an initial response to the question: “How do you know if a three-dimensional figure is a prism?” Give students time to meet with 2–3 partners, to share and get feedback on their responses. Provide students with prompts for feedback that will help their partner strengthen their ideas and clarify their language (e.g., “What are some properties of prisms?”, “Can you give an example and non-example?”, etc.). Students can borrow ideas and language from each partner to refine and clarify their explanation. This will also help students to build and describe the three-dimensional figures used in this lesson and the unit.

Design Principle(s): Optimize output (for explanation); Maximize meta-awareness

12.3 Can You Find the Volume?

15 minutes (there is a digital version of this activity)

The purpose of this activity is for students get hands-on experience with polyhedra, recognizing whether a figure is a prism and if so, determining which face is the base of the prism. Once students determine which face is the base, they use a ruler marked in inches to measure the height of the prism. The area of each face is labeled on the shape so that students do not get bogged down with calculating the base area and can focus on using the area to find the volume.

Instead of creating enough sets of polyhedra for every group to have one of every shape at the same time, consider having the students pass the shapes from one group to the next or rotate around to different stations so that fewer sets of shapes have to be constructed.

Addressing

- 7.G.B.6

Instructional Routines

- MLR3: Clarify, Critique, Correct

Launch

Arrange students in groups of 3–4. Distribute the three-dimensional figures that were already assembled from the nets in the Instructional master and rulers marked in centimeters. Give students 1–2 minutes of quiet work time with the polyhedra given to their group, have groups exchange objects so that each group gets to examine each figure. Follow with a whole-class discussion.

Students using the digital version have an applet with the five polyhedra in 3D. Students can rotate the view using the tool marked by two intersecting, curved arrows. Note that each polyhedron has only one label per unique face. If no other measurements are shown, the faces are congruent.

Students can use the distance tool, marked with the "cm," to find the height or length of any segment. Troubleshooting tip: the cursor must be on the 3D Graphics window for the full toolbar to appear.

Anticipated Misconceptions

Some students may say that Figure A is not a prism because it is a cube. Ask them whether the cross sections would be identical if you made various cuts parallel to one side. Explain that a cube is a special type of square prism where the height of the prism matches the side lengths of the base. Consider making a comparison to the fact that a square is a special type of rectangle.

Student Task Statement

Your teacher will give you a set of three-dimensional figures.

1. For each figure, determine whether the shape is a prism.
2. For each prism:
 - a. Find the area of the base of the prism.
 - b. Find the height of the prism.
 - c. Calculate the volume of the prism.

| | Is it a prism? | area of prism base (cm ²) | height (cm) | volume (cm ³) |
|----------|----------------|---------------------------------------|-------------|---------------------------|
| figure A | | | | |
| figure B | | | | |
| figure C | | | | |
| figure D | | | | |
| figure E | | | | |
| figure F | | | | |

Student Response

1. Yes, it is a square prism. Any cross section parallel to any of the faces will be the same size square, so it is a prism.
2. Yes, it is a pentagonal prism. Any cross section parallel to the pentagon base will be the same size pentagon, so it is a prism.
3. No, it is a hexagonal pyramid. Cross sections parallel to the hexagon will be smaller hexagons.
4. Yes, it is a triangular prism. Any cross section parallel to the triangle base will be the same size triangle, so it is a prism.

5. No. Cross sections are not the same all the way through the object.
6. Yes, it is a rhombal prism. Any cross section parallel to the rhombus base will be the same size rhombus, so it is a prism.

| | Is it a prism? | area of prism base (cm ²) | height (cm) | volume (cm ³) |
|----------|----------------|---------------------------------------|-------------|---------------------------|
| figure A | Yes | 25 | 5 | 125 |
| figure B | Yes | 15 | 15 | 225 |
| figure C | No | | | |
| figure D | Yes | 24 | 6 | 144 |
| figure E | No | | | |
| figure F | Yes | 35 | 3 | 105 |

Are You Ready for More?

Imagine a large, solid cube made out of 64 white snap cubes. Someone spray paints all 6 faces of the large cube blue. After the paint dries, they disassemble the large cube into a pile of 64 snap cubes.

1. How many of those 64 snap cubes have exactly 2 faces that are blue?
2. What are the other possible numbers of blue faces the cubes can have? How many of each are there?
3. Try this problem again with some larger-sized cubes that use more than 64 snap cubes to build. What patterns do you notice?

Student Response

1. 2 faces: 24 cubes
2. 3 faces: 8 cubes, 1 face: 24 cubes, 0 faces: 8 cubes.
3. Answers vary. Sample response: There are always 8 cubes with 3 blue faces, there is a cube on the inside with side length 2 units less than the large cube that doesn't get painted at all. (Students can make similar observations and perhaps find formulas for the number of cubes with 1 or 2 blue faces.)

Activity Synthesis

Poll the class for answers to the first column of the table. Make sure the class agrees about answers before proceeding. Select students to provide their answers to each part of the table and an explanation. Display answers on the table for all to see. Ask students:

- “What is different about the structure of non-prisms in comparison to prisms?” (The prisms have multiple layers of the same base, where the non-prism does not have that.)
- “Why can’t you use ‘area of the base times the height’ to calculate the volume of the figures that were not prisms?” (Because the non-prism isn’t made up of multiple layers of the same base.)

Access for English Language Learners

Writing, Speaking: MLR3 Clarify, Critique, Correct. Use this routine to support student reasoning about whether a figure is a prism or not. Before students share their answers, display an incorrect answer showing conceptual (or common) errors. For example, “Figure A is not a prism because it is a cube.” or “Figure B is a prism because its base is a rectangle.” Ask students to work with a partner to identify the errors and critique the reasoning shown. Provide questions for discussion such as, “What is unclear?” or “Are there any errors?” Give students 2–3 minutes of quiet time to revise the original statement, by drawing on the conversations with their partners. Improved statements should draw on properties of prisms, such as: cross sections are parallel to the base and are identical copies. This will facilitate students’ understanding of prisms and their ability to evaluate, and improve on, the written mathematical arguments of others.

Design Principle(s): Optimize output (for explanation); Maximize meta-awareness

12.4 What’s the Prism’s Height?

Optional: 10 minutes

The purpose of this activity is for students to work backwards from the volume to the height of a prism. Students see that for two prisms to have the same volume, the one with the smaller base has the taller height and the one with the larger base has the shorter height. The grid helps students find the area of the base so they can focus their attention on what it means to have a prism made out of stacks of layers of the same base.

Addressing

- 7.G.B.6

Instructional Routines

- MLR8: Discussion Supports

Launch

Arrange students in groups of 2. Give students 5 minutes of quiet work time followed by time to discuss their thinking with a partner. Follow with a whole-class discussion.

Access for Students with Disabilities

Representation: Develop Language and Symbols. Use virtual or concrete manipulatives to connect symbols to concrete objects or values. Provide students with geometric solids or snap cubes and a printed copy of the student task statement to draw on or annotate.

Supports accessibility for: Conceptual processing

Student Task Statement

There are 4 different prisms that all have the same volume. Here is what the base of each prism looks like.

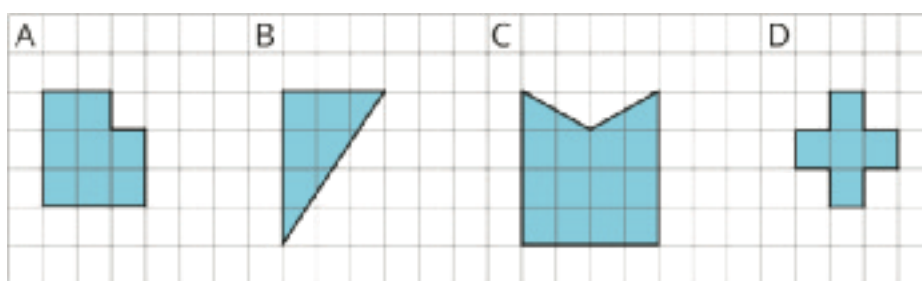

1. Order the prisms from shortest to tallest. Explain your reasoning.
2. If the volume of each prism is 60 units^3 , what would be the height of each prism?
3. For a volume other than 60 units^3 , what could be the height of each prism?
4. Discuss your thinking with your partner. If you disagree, work to reach an agreement.

Student Response

1. D, B, A, C, since a larger base area means the height of the prism must be shorter to maintain the same volume.
2. If the volume of all 4 prisms is 60 units^3 , prism A is 7.5 units tall, prism B is 10 units tall, prism C is 5 units tall, and prism D is 12 units tall.
3. Answers vary. Sample responses:
 - The volume of all 4 prisms is 48 units^3 if prism A is 6 units tall, B is 8 units tall, C is 4 units tall, and D is 2.4 units tall.
 - The volume of all 4 prisms is 120 units^3 if prism A is 15 units tall, B is 20 units tall, C is 10 units tall, and D is 6 units tall.

Activity Synthesis

Select students to share their responses and reasoning. If not brought up in student's explanation, explain that for the last problem, there is more than one possible correct answer. The smallest

possible volume that involves all whole number side lengths is 120 units³, but there is nothing in the problem that requires all the heights to be whole numbers.

To highlight connections to calculating volume, ask:

- “How do you calculate the volume of a prism?” (Display the equation for all to see: $V = B \cdot h$.)
- “Since $V = B \cdot h$, how could we find the area of the base if we knew the volume and height of the prism?” (Display the equation for all to see: $B = V \div h$.)
- “If we keep the volume the same, what happens to the height when we increase the area of the base?” (It decreases.)
- “If we keep the height the same, what happens to the volume when we increase the area of the base?” (It increases.)

Access for English Language Learners

Speaking: MLR8 Discussion Supports. Use this routine to support whole-class discussion. For each response that is shared, ask students to restate and/or revoice what they heard using precise mathematical language. Consider providing students time to restate what they hear to a partner, before selecting one or two students to share with the class. Ask the original speaker if their peer was accurately able to restate their thinking. Call students' attention to any words or phrases that helped to clarify the original statement. This will provide more students with an opportunity to produce language as they interpret the reasoning of others.

Design Principle(s): Support sense-making

Lesson Synthesis

- “What information do we need to calculate the volume of a prism?” (Area of the base and the height)
- “Explain how you could use layers to find the volume of a prism.” (If you look at the first layer of a prism, you can find how many cubes are in that layer by finding the area of the base. Once you find the number of cubes on the first layer, you multiply that by the number of layers it takes to stack up to the height of the prism.)
- “Two prisms have the same base area and height, but different base shapes. Which prism has a greater volume? Explain.” (The two prisms have the same volume. The shape of the base does not matter if it is a prism, only the base area matters.)
- “Two clay prisms use the same amount of clay to make them, but the first has a larger height than the second. Which prism has a larger base area?” (The second prism will have a larger base area since a shorter height means a larger base area if the volume is held constant. Imagine squashing the first one down in a nice way to make a shorter, fatter version.)

12.5 Octagonal Box

Cool Down: 5 minutes

Addressing

- 7.G.B.6

Student Task Statement

A box is shaped like an octagonal prism. Here is what the base of the prism looks like.

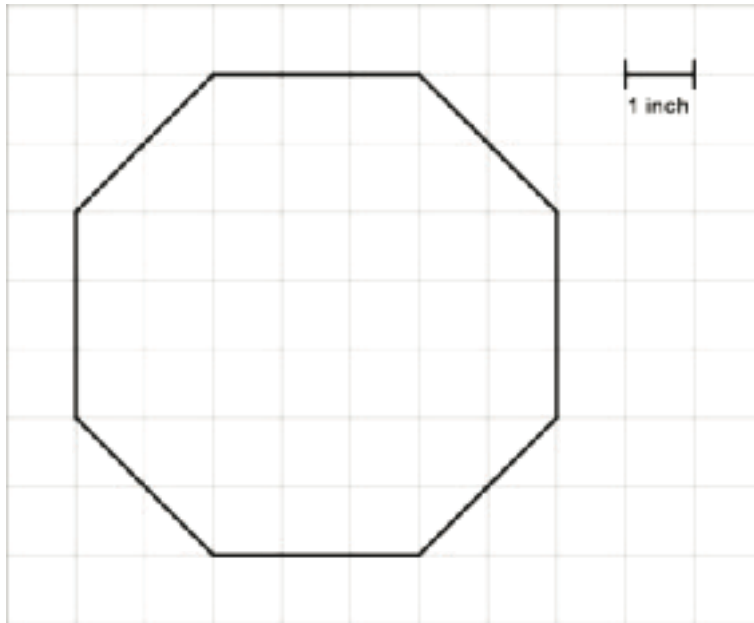

For each question, make sure to include the unit with your answer and explain or show your reasoning.

1. If the height of the box is 7 inches, what is the volume of the box?
2. If the volume of the box is 123 in^3 , what is the height of the box?

Student Response

1. 287 in^3 , because the base has an area of 41 in^2 and $41 \cdot 7 = 287$.
2. 3 in, because $41 \cdot 3 = 123$.

Student Lesson Summary

Any cross section of a prism that is parallel to the base will be identical to the base. This means we can slice prisms up to help find their volume. For example, if we have a rectangular prism that is 3 units tall and has a base that is 4 units by 5 units, we can think of this as 3 layers, where each layer has $4 \cdot 5$ cubic units.

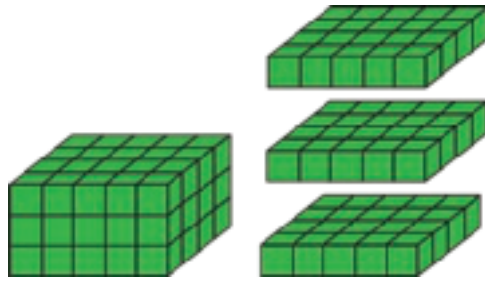

That means the volume of the original rectangular prism is $3(4 \cdot 5)$ cubic units.

This works with any prism! If we have a prism with height 3 cm that has a base of area 20 cm^2 , then the volume is $3 \cdot 20 \text{ cm}^3$ regardless of the shape of the base. In general, the volume of a prism with height h and area B is

$$V = B \cdot h$$

For example, these two prisms both have a volume of 100 cm^3 .

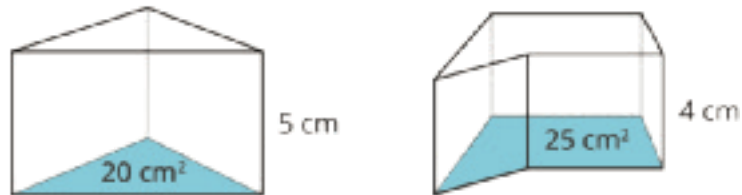

Glossary

- volume

Lesson 12 Practice Problems

Problem 1

Statement

- a. Select all the prisms.
- b. For each prism, shade one of its bases.

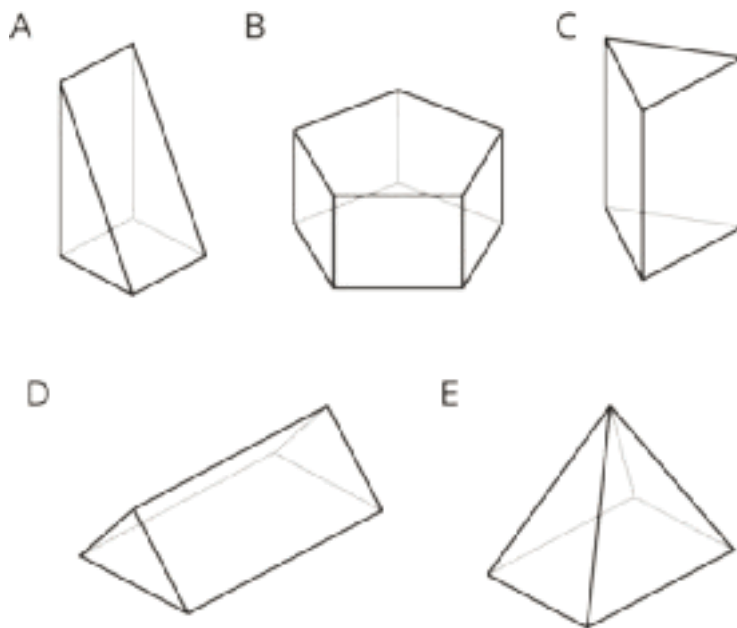

Solution

- a. A, B, C, D

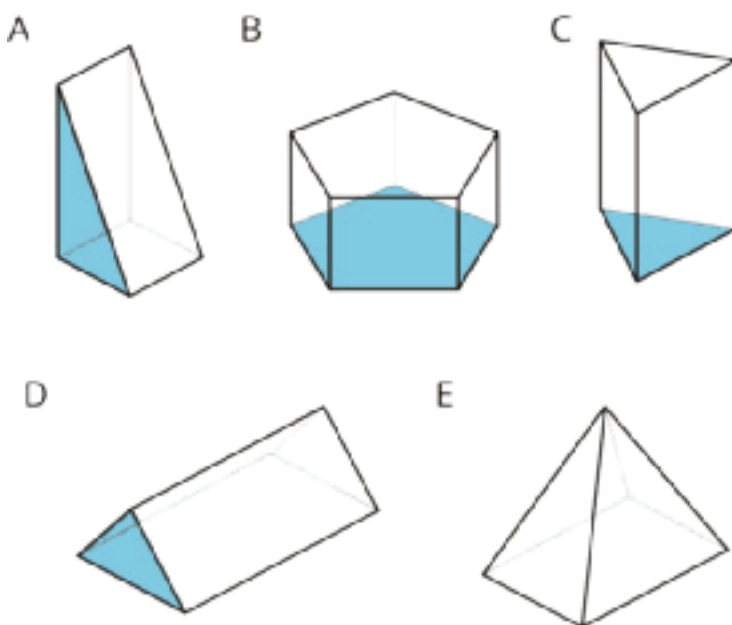

- b.

Problem 2

Statement

The volume of both of these trapezoidal prisms is 24 cubic units. Their heights are 6 and 8 units, as labeled. What is the area of a trapezoidal base of each prism?

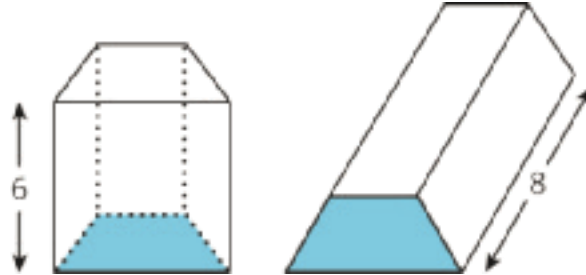

Solution

The prism with a height of 6 units has a base with area 4 square units, because $24 \div 6 = 4$. The prism with a height of 8 units has a base with area 3 square units, because $24 \div 8 = 3$.

Problem 3

Statement

Two angles are complementary. One has a measure of 19 degrees. What is the measure of the other?

Solution

71 degrees

(From Unit 7, Lesson 2.)

Problem 4

Statement

Two angles are supplementary. One has a measure that is twice as large as the other. Find the two angle measures.

Solution

60° and 120°

(From Unit 7, Lesson 2.)

Problem 5

Statement

Match each expression in the first list with an equivalent expression from the second list.

A. $7(x + 2) - x + 3$

B. $6x + 3 + 4x + 5$

C. $\frac{-2}{5}x - 7 + \frac{3}{5}x - 3$

D. $8x - 5 + 4 - 9$

E. $24x + 36$

1. $\frac{1}{5}x - 10$

2. $6x + 17$

3. $2(5x + 4)$

4. $12(2x + 3)$

5. $8x + (-5) + 4 + (-9)$

Solution

- A: 2
- B: 3
- C: 1
- D: 5
- E: 4

(From Unit 6, Lesson 22.)

Problem 6

Statement

Clare paid 50% more for her notebook than Priya paid for hers. Priya paid x for her notebook and Clare paid y dollars for hers. Write an equation that represents the relationship between y and x .

Solution

$$y = 1.5x \text{ (or equivalent)}$$

(From Unit 4, Lesson 8.)

Lesson 13: Decomposing Bases for Area

Goals

- Critique (orally) different methods for decomposing and calculating the area of a prism's base.
- Explain (orally and in writing) how to decompose and calculate the area of a prism's base, and then use it to calculate the prism's volume.

Learning Targets

- I can calculate the the volume of a prism with a complicated base by decomposing the base into quadrilaterals or triangles.

Lesson Narrative

In this lesson, students continue working with the volume of right prisms. They encounter prisms where the base is composed of triangles and rectangles, and decompose the base to calculate the area. They also work with shapes such as heart-shaped boxes or house-shaped figures where they have to identify the base in order to see the shape as a prism and calculate its volume (MP1). When students look for the prism structure in a shape to solve a problem, they are engaging in MP7.

Alignments

Addressing

- 7.G.A.3: Describe the two-dimensional figures that result from slicing three-dimensional figures, as in plane sections of right rectangular prisms and right rectangular pyramids.
- 7.G.B.6: Solve real-world and mathematical problems involving area, volume and surface area of two- and three-dimensional objects composed of triangles, quadrilaterals, polygons, cubes, and right prisms.

Instructional Routines

- MLR5: Co-Craft Questions
- MLR7: Compare and Connect

Student Learning Goals

Let's look at how some people use volume.

13.1 Are These Prisms?

Warm Up: 10 minutes

The purpose of this warm-up is for students to recognize prisms and their bases. This concept reinforces what was discussed in the previous lesson where students found the volume of different prisms and non-prisms. Students first determine if a given figure is a prism or not and then shade and describe the base of the prism. As students work on the task, monitor for students who are using precise language to describe the reason a figure is a prism.

Addressing

- 7.G.A.3

Launch

Arrange students in groups of 2. Give students 1 minute of quiet work time followed by time to discuss their answers with a partner. Follow with a whole-class discussion.

Anticipated Misconceptions

If students struggle to see why figure B is a prism, ask them to point out the base of the figure. It might be helpful to remind them that the base of the figure might not always be on the bottom.

Student Task Statement

1. Which of these solids are prisms? Explain how you know.

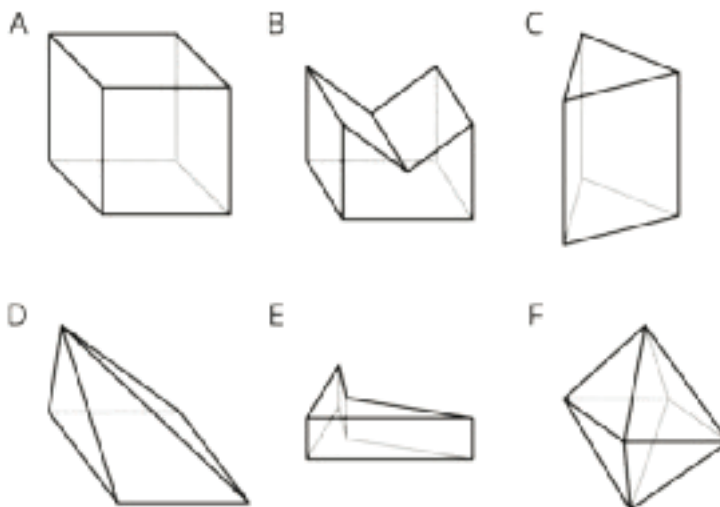

2. For each of the prisms, what does the base look like?
 - a. Shade one base in the picture.
 - b. Draw a cross section of the prism parallel to the base.

Student Response

1. A, B, C, and E are prisms since there is a base shape that is the same on each end with vertices connected by line segments.
2. The base for A is a square (any of the faces). The base for B is a pentagon (in the front or back). The base for C is a triangle (on the top or bottom). The base for E is a quadrilateral (on the top or bottom).

Activity Synthesis

Select previously identified students to share their reasoning. Invite students to share the bases they shaded and the drawings of the cross sections. If not mentioned by students, remind them

that a figure is considered a prism if the cross section, when cut parallel to the base, has the same shape as the base of the figure.

13.2 A Box of Chocolates

15 minutes

In this activity, students practice mentally dissecting a prism with a non-rectangular base into simpler prisms. The dissection corresponds to a dissection of the base into simpler figures. This expands on students' ability to calculate the area of a base of a figure that has a rectangular base because here the base is not a rectangle. This prepares students to calculate the volume of this figure and other figures in future lessons.

As students work in their groups, monitor for the different ways students are decomposing or constructing the base of the figure into more familiar shapes.

Addressing

- 7.G.B.6

Instructional Routines

- MLR5: Co-Craft Questions

Launch

Arrange students in groups of 3. Display the image for all to see throughout the activity. Tell students this is what the heart-shaped box mentioned in the task statement looks like.



Give students 2–3 minutes of quiet work time followed by a whole-class discussion.

Access for Students with Disabilities

Engagement: Internalize Self Regulation. Check for understanding by inviting students to rephrase directions in their own words. Provide a project checklist that chunks the various steps of the activity into a set of manageable tasks.

Supports accessibility for: Organization; Attention

Access for English Language Learners

Conversing: MLR5 Co-Craft Questions. Display the image of the heart-shaped box and initial task statement without revealing the questions that follow. Ask students to write mathematical questions about the situation. Invite students to share their questions with their group and choose 1 question from their group to share with the class. Listen for questions that connect to finding the area of the base of the heart-shaped prism (e.g., “What’s the most 1 inch by 1 inch chocolates that can fit along the bottom of the box?”). This helps students produce the language of mathematical questions and begin reasoning about different approaches for finding the area of a non-rectangular shape.

Design Principle(s): Cultivate conversation

Student Task Statement

A box of chocolates is a prism with a base in the shape of a heart and a height of 2 inches. Here are the measurements of the base.

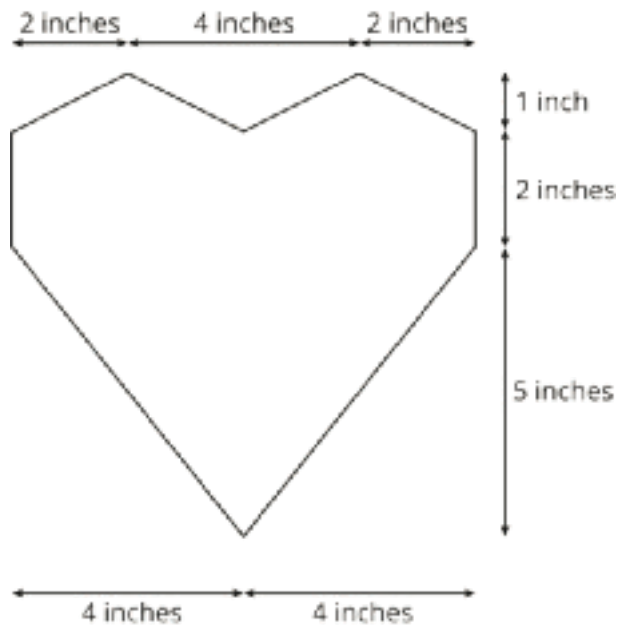

To calculate the volume of the box, three different students have each drawn line segments showing how they plan on finding the area of the heart-shaped base.

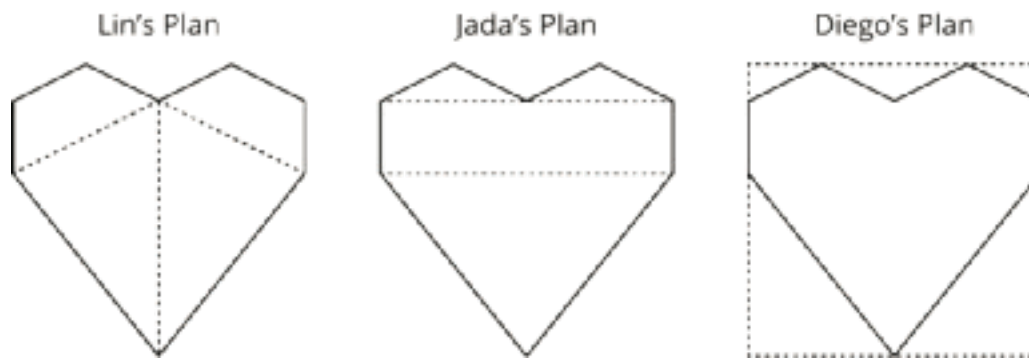

1. For each student's plan, describe the shapes the student must find the area of and the operations they must use to calculate the total area.
2. Although all three methods could work, one of them requires measurements that are not provided. Which one is it?
3. Between you and your partner, decide which of you will use which of the remaining two methods.
4. Using the quadrilaterals and triangles drawn in your selected plan, find the area of the base.
5. Trade with a partner and check each other's work. If you disagree, work to reach an agreement.
6. Return their work. Calculate the volume of the box of chocolates.

Student Response

1. Lin needs to add the areas of the 2 trapezoids and the 2 triangles. Jada needs to add the areas of the 3 triangles and of the rectangle. Diego needs to subtract the areas of the 5 triangles that are not part of the heart design from the area of the square that bounds it.
2. Lin's plan requires measurements that are not given, specifically the bases of each figure and the heights of the trapezoids.
3. Either Jada's plan or Diego's plan.
4. The area of the base is 40 square inches. Using Jada's plan, each of the top triangles has an area of 2 square inches because $\frac{1}{2} \cdot 1 \cdot 4 = 2$. The center rectangle has an area of 16 square inches because $2 \cdot (4 + 4) = 16$. The lower triangle has an area of 20 square inches, because $\frac{1}{2} \cdot (4 + 4) \cdot 5 = 20$. The total area is 40 square inches because $2 + 2 + 16 + 20 = 40$. Using Diego's plan, the bounding square has an area of 64 square inches because $(1 + 2 + 5) \cdot (4 + 4) = 64$. The top 2 corner triangles each have an area of 1 square inch, because $\frac{1}{2} \cdot 2 \cdot 1 = 1$. The top center triangle has an area of 2 square inches, because $\frac{1}{2} \cdot 4 \cdot 1 = 2$. Each of the 2 lower corner triangles has an area of 10 square inches, because $\frac{1}{2} \cdot 4 \cdot 5 = 10$. The total area of all of the triangles is 24 square inches, because

$1 + 1 + 2 + 10 + 10 = 24$. The total area of the heart-shaped base 40 square inches, because $64 - 24 = 40$.

5. 40 square inches

6. 80 cubic inches, because $40 \cdot 2 = 80$.

Are You Ready for More?

The box has 30 pieces of chocolate in it, each with a volume of 1 in^3 . If all the chocolates melt into a solid layer across the bottom of the box, what will be the height of the layer?

Student Response

$\frac{3}{4}$ in

Activity Synthesis

Select students to share whose method they decided to use and why. Ask students:

- “Whose method could not be used? Why not?” (Lin’s, because we don’t know the base and height of the trapezoids.)
- “How did you find the areas of the base?”
- “What was different about the base of this figure in comparison to other bases we have worked with?” (This base needs to be decomposed to calculate its area.)
- “What was the first thing you did to find the volume?” (Use the area of the base and multiply it by the height of the figure.)
- “Why would a chocolatier want to know the volume of a heart shaped box like this?” (He may want to know how many candies can fit inside of a box.)

Explain to students that they might encounter figures that have non-rectangular bases in future activities or lessons. It will be important for them to think about different strategies to calculate the area of the base.

13.3 Another Prism

10 minutes

In this activity, students practice finding the volume of another prism with a non-rectangular base by applying the formula $\text{Volume} = (\text{Area of the base}) \cdot (\text{Height of the prism})$.

As students work on the task, monitor for students who decompose or compose the base of the figure into more familiar shapes.

Addressing

- 7.G.B.6

Instructional Routines

- MLR7: Compare and Connect

Launch

Arrange students in groups of 2. Give students 1–2 minutes of quiet work time followed by time to discuss their work with a partner. Follow with a whole-class discussion.

Access for Students with Disabilities

Representation: Develop Language and Symbols. Display or provide charts with figures and the formula for finding the volume of a prism with a non-rectangular base.

Supports accessibility for: Conceptual processing; Memory

Anticipated Misconceptions

If students mistake the rectangle for the base of the figure, ask students how we know that this figure is a prism and what the base of this figure needs to be in order to consider it a prism.

Student Task Statement

A house-shaped prism is created by attaching a triangular prism on top of a rectangular prism.

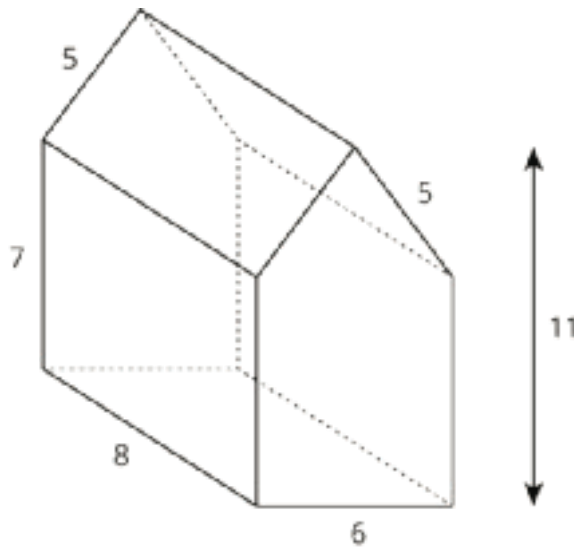

1. Draw the base of this prism and label its dimensions.
2. What is the area of the base? Explain or show your reasoning.
3. What is the volume of the prism?

Student Response

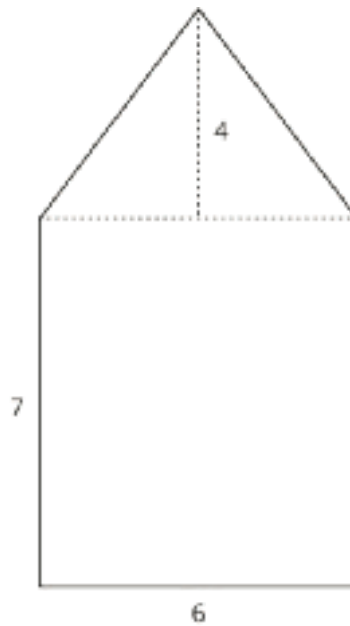

- 1.
2. 54 square units. This shape can be divided into a rectangle and triangle. The area of the rectangle is $6 \cdot 7 = 42$. The area of the triangle is $\frac{1}{2} \cdot 4 \cdot 6 = 12$. So, the area of the base is $42 + 12 = 54$.
3. 432 cubic units. Since the volume of a prism is the area of the base times the height of the prism, the volume is $8 \cdot 54 = 432$.

Activity Synthesis

Select previously identified students to share the different methods for calculating the area of base. If not brought up by students, explain to students that the base of this figure can be either decomposed into rectangles and triangles or composed into a larger rectangle by adding two additional triangles. Ask students how they used the area of the base to calculate the volume of the figure (area of the base multiplied by the height).

Access for English Language Learners

Speaking, Listening: MLR7 Compare and Connect. Use this routine as students explain their strategy for calculating the volume of the prism. Ask students to consider what is the same and what is different about each approach. Draw students' attention to the different ways the figure was decomposed and highlight any use of mathematical language (e.g., decompose, rectangle, triangle, trapezoid). These exchanges can strengthen students' mathematical language use and reasoning of prisms.

Design Principle(s): Optimize meta-awareness; Support sense-making

Lesson Synthesis

- “When the base is not a rectangle or triangle, what are some methods for finding the area?”
(We can cut the base apart into rectangles and triangles or imagine a larger shape that has been cut into the base.)

Here, we mostly imagined cutting the base apart to find its area, but we could have imagined cutting the original object into smaller objects, then finding the volume of each piece and adding them together.

13.4 Volume of a Pentagonal Prism

Cool Down: 5 minutes

Addressing

- 7.G.B.6

Launch

If desired, provide copies of the two-dimensional view of just the base of the prism.

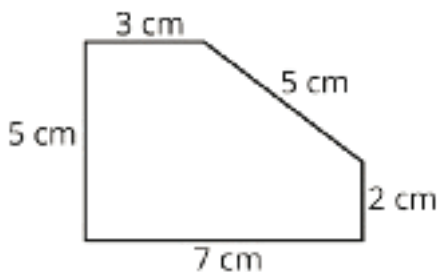

Student Task Statement

Here is a prism with a pentagonal base. The height is 8 cm.

What is the volume of the prism? Show your thinking. Organize it so it can be followed by others.

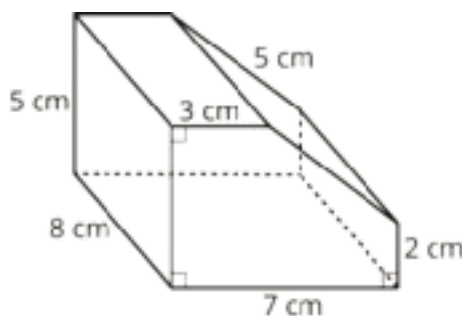

Student Response

The volume is 232 cm^3 . The area of the base is 29 cm^2 and can be found in multiple ways, but one way is to consider a 5 by 7 rectangle with a right triangle cut off, then $5 \cdot 7 - \frac{1}{2} \cdot 4 \cdot 3 = 29$. Since the height is 8 cm, the volume is calculated by $29 \cdot 8 = 232$.

Student Lesson Summary

To find the area of any polygon, you can decompose it into rectangles and triangles. There are always many ways to decompose a polygon.

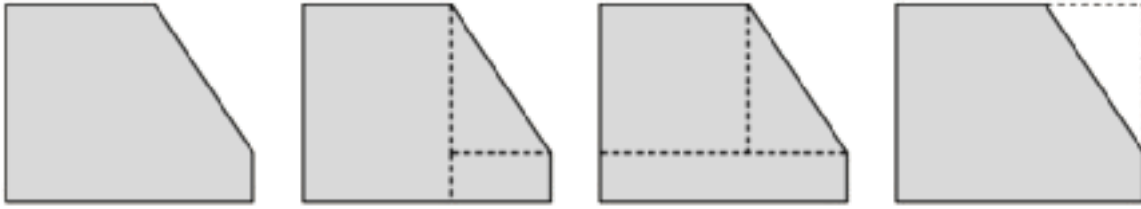

Sometimes it is easier to enclose a polygon in a rectangle and subtract the area of the extra pieces.

To find the volume of a prism with a polygon for a base, you find the area of the base, B , and multiply by the height, h .

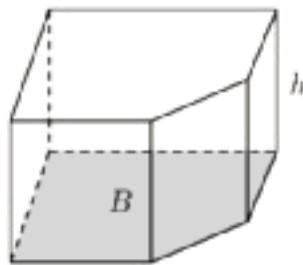

$$V = Bh$$

Lesson 13 Practice Problems

Problem 1

Statement

You find a crystal in the shape of a prism. Find the volume of the crystal.

The point B is directly underneath point E , and the following lengths are known:

- From A to B : 2 mm
- From B to C : 3 mm
- From A to F : 6 mm
- From B to E : 10 mm
- From C to D : 7 mm
- From A to G : 4 mm

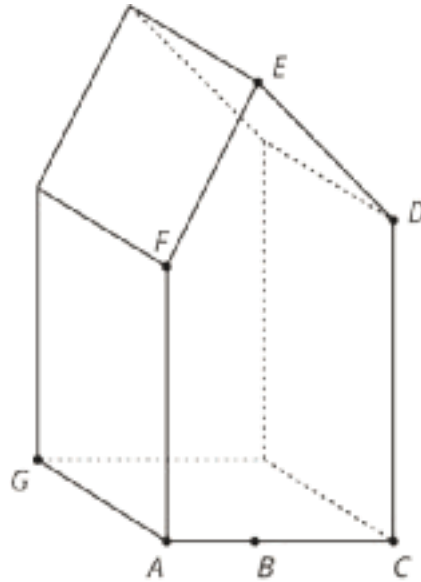

Solution

166 cubic millimeters

Problem 2

Statement

A rectangular prism with dimensions 5 inches by 13 inches by 10 inches was cut to leave a piece as shown in the image. What is the volume of this piece? What is the volume of the other piece not pictured?

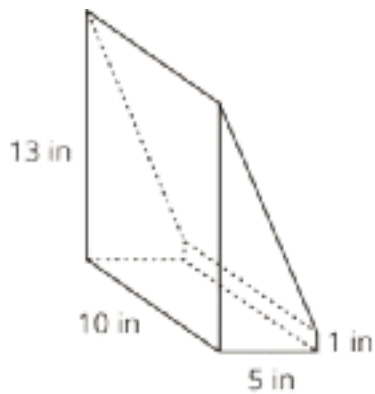

Solution

350 cubic inches, 300 cubic inches

Problem 3

Statement

A triangle has one side that is 7 cm long and another side that is 3 cm long.

- Sketch this triangle and label your sketch with the given measures. (If you are stuck, try using a compass or cutting some straws to these two lengths.)
- Draw one more triangle with these measures that is not identical to your first triangle.
- Explain how you can tell they are not identical.

Solution

- Answers vary.
- Answers vary.
- Responses vary. Sample response: If I cut one of the triangles out and place it on top of the other triangles, the triangles do not match up.

(From Unit 7, Lesson 9.)

Problem 4

Statement

Select all equations that represent a relationship between angles in the figure.

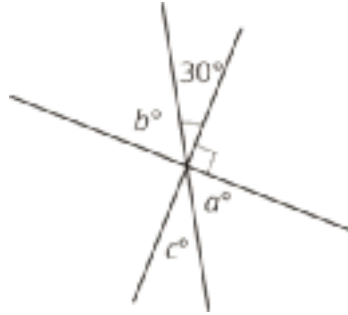

- A. $90 - 30 = b$
- B. $30 + b = a + c$
- C. $a + c + 30 + b = 180$
- D. $a = 30$
- E. $a = c = 30$
- F. $90 + a + c = 180$

Solution

["A", "B", "C", "F"]

(From Unit 7, Lesson 4.)

Problem 5

Statement

A mixture of punch contains 1 quart of lemonade, 2 cups of grape juice, 4 tablespoons of honey, and $\frac{1}{2}$ gallon of sparkling water. Find the percentage of the punch mixture that comes from each ingredient. Round your answers to the nearest tenth of a percent. (Hint: 1 cup = 16 tablespoons)

Solution

Lemonade: 28.1%, Grape Juice: 14.0%, Honey: 1.8%, Seltzer Water: 56.1%

(From Unit 4, Lesson 9.)

Lesson 14: Surface Area of Right Prisms

Goals

- Calculate the surface area of a prism, and explain (in writing) the solution method.
- Comprehend that surface area and volume are two different attributes of three-dimensional objects and are measured in different units.
- Interpret different methods for calculating the surface area of a prism, and evaluate (orally and in writing) their usefulness.

Learning Targets

- I can find and use shortcuts when calculating the surface area of a prism.
- I can picture the net of a prism to help me calculate its surface area.

Lesson Narrative

In grade 6, students used nets made up of rectangles and triangles to find the surface area of three-dimensional figures. In this lesson they find surface areas of prisms, and see that structure of a prism allows for shortcuts in adding up the areas of the faces. They see that if the prism is sitting on its base, then the vertical sides can be unfolded into a single rectangle whose height is the height of the prism and whose length is the perimeter of the base. The purpose of the lesson is not to come up with a formula for the surface area of a prism, but to help students see and make use of the structure of the prism to find surface area efficiently (MP7).

Alignments

Building On

- 3.MD.C.5: Recognize area as an attribute of plane figures and understand concepts of area measurement.
- 3.MD.D.8: Solve real world and mathematical problems involving perimeters of polygons, including finding the perimeter given the side lengths, finding an unknown side length, and exhibiting rectangles with the same perimeter and different areas or with the same area and different perimeters.
- 6.G.A.4: Represent three-dimensional figures using nets made up of rectangles and triangles, and use the nets to find the surface area of these figures. Apply these techniques in the context of solving real-world and mathematical problems.

Addressing

- 7.G.B.6: Solve real-world and mathematical problems involving area, volume and surface area of two- and three-dimensional objects composed of triangles, quadrilaterals, polygons, cubes, and right prisms.

Building Towards

- 7.G.B.6: Solve real-world and mathematical problems involving area, volume and surface area of two- and three-dimensional objects composed of triangles, quadrilaterals, polygons, cubes, and right prisms.

Instructional Routines

- MLR1: Stronger and Clearer Each Time
- MLR8: Discussion Supports

Required Materials

Materials assembled from the Instructional master

Required Preparation

Assemble the net from the Instructional master to make a prism with a base in the shape of a plus sign. Make sure to print the Instructional master at 100% scale so the dimensions are accurate. This prism will be used for both the warm-up and the following activity.

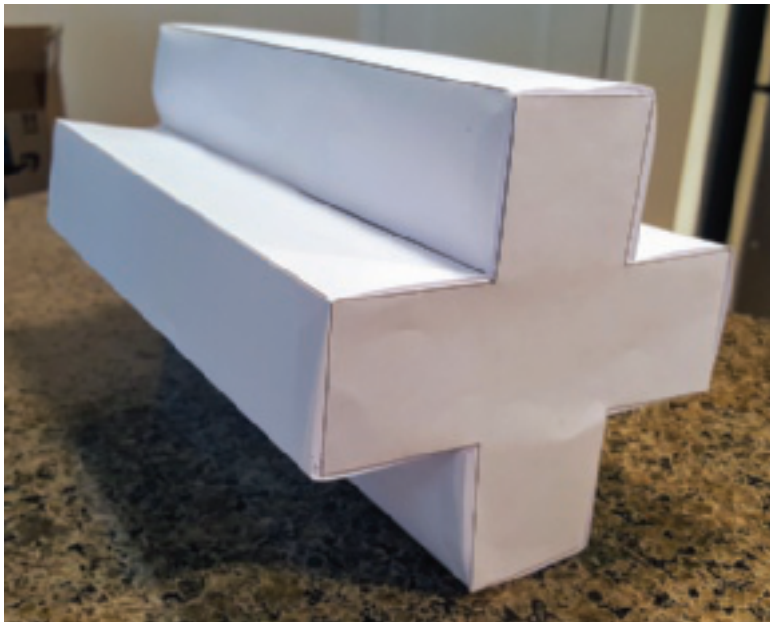

Student Learning Goals

Let's look at the surface area of prisms.

14.1 Multifaceted

Warm Up: 5 minutes

The purpose of this warm-up is for students to recognize important parts of solids in anticipation of computing volume and surface area. The figure used in the next activity is introduced in this warm-up as a way for students to start thinking about parts of solids and how we use them to compute surface area or volume.

Building On

- 3.MD.C.5
- 3.MD.D.8
- 6.G.A.4

Building Towards

- 7.G.B.6

Launch

Arrange students in groups of 2. Display the prism assembled from the Instructional master for all to see. Give students 1 minute of quiet think time followed by time to discuss their ideas with a partner. Follow with a whole-class discussion.

Student Task Statement

Your teacher will show you a prism.

1. What are some things you could measure about the object?
2. What units would you use for these measurements?

Student Response

1. Answers vary. Sample responses: You could measure the length of each of the edges of the object. You could measure the volume of the object. You could find the area of the faces.
2. Answers vary. Sample responses: Lengths could be measured in inches or centimeters. Volume could be measured in cubic inches, cubic centimeters, or milliliters. Area could be measured in square inches or square centimeters.

Activity Synthesis

Select students to share their responses. Ask students to think about units that do not make sense to use for measurements (feet, miles, yards, etc). Invite students to share their explanations of why these units do not make sense to use.

14.2 So Many Faces

15 minutes

In this activity, students make sense of three different methods for calculating the surface area of a figure. Three different methods are described to students and they are asked to determine which one they agree with (if any) (MP3). They then think about generalizing the methods to figure out if they would work for any prism. This activity connects to work they did with nets in a previous grade and builds upon strategies students might have to calculate surface area.

As students work on the task, monitor for students who understand the different methods and can explain if any of them will work for any other prisms.

Note: It is not important for students to learn the term “lateral area.”

Addressing

- 7.G.B.6

Instructional Routines

- MLR1: Stronger and Clearer Each Time

Launch

Arrange students in groups of 2. Display the prism assembled previously in the warm-up for all to see. Ask students: “how might we find surface area of this prism?” Invite students to share their ideas. Give students 1 minute of quiet think to read Noah’s method for calculating surface area followed by time discuss whether they agree with Noah or not. Repeat this process for the remaining two methods. Once all three methods have been discussed give students 1–2 minutes of quiet work time to answer the rest of the questions in the task statement.

Access for Students with Disabilities

Representation: Internalize Comprehension. Demonstrate and encourage students to use color coding and annotations to highlight connections between representations in a problem. For example, use different colors to represent each of Noah, Elena and Andre’s methods.

Supports accessibility for: Visual-spatial processing

Anticipated Misconceptions

Students may think that Andre’s method will not work for all prisms, because it will not work for solids that have a hole in their base and therefore more lateral area on the inside. Technically, these solids are not prisms, because their base is not a polygon. However, students could adapt Andre’s method to find the surface area of a solid composed of a prism and a hole.

Student Task Statement

Here is a picture of your teacher's prism:

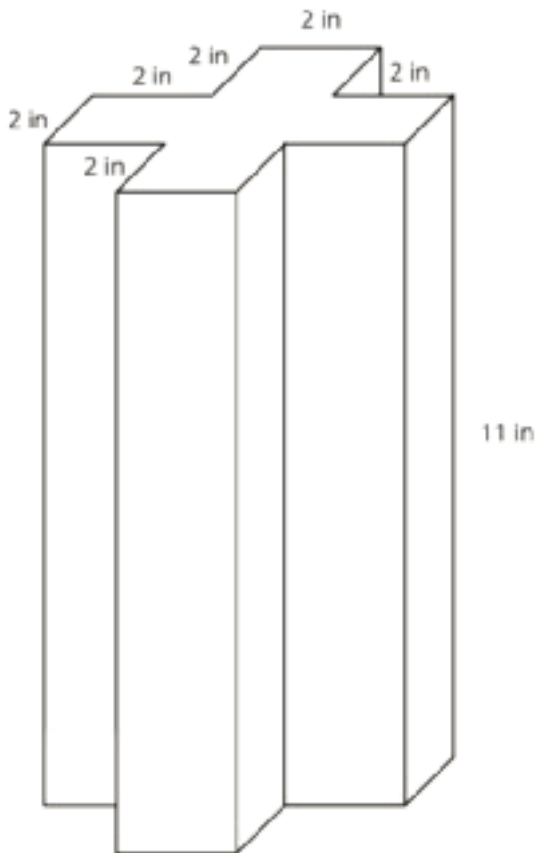

Three students are trying to calculate the **surface area** of this prism.

- Noah says, "This is going to be a lot of work. We have to find the areas of 14 different faces and add them up."
- Elena says, "It's not so bad. All 12 rectangles are identical copies, so we can find the area for one of them, multiply that by 12 and then add on the areas of the 2 bases."
- Andre says, "Wait, I see another way! Imagine unfolding the prism into a net. We can use 1 large rectangle instead of 12 smaller ones."

1. Do you agree with any of them? Explain your reasoning.
2. How big is the "1 large rectangle" Andre is talking about? Explain or show your reasoning. If you get stuck, consider drawing a net for the prism.
3. Will Noah's method always work for finding the surface area of any prism? Elena's method? Andre's method? Be prepared to explain your reasoning.
4. Which method do you prefer? Why?

Student Response

1. I agree with all three of them. Noah's method will work, but is not the most efficient. Elena's method is an improvement because we don't have to do the same calculation multiple times. Andre's method is more complicated to think about, but it should also work.
2. The height of the rectangle will be the same as the height of the prism, 11 inches. The length of the rectangle must wrap around the entire base, so it will be the same as the perimeter of the base, 24 inches.
3. Noah's method will always work for any prism. Elena's method only works when each line segment in the base is the same length, so it will not work for all figures. Andre's method will work for all prisms because the long rectangle can fold around any base.

4. Answers vary. Sample response: I prefer Andre's method because it is not too difficult once you understand it and only needs two areas (the base and the long rectangle).

Activity Synthesis

Select previously identified students to share their reasoning. If not brought up in students' explanations, display the image for all to see and point out to students that the length of the "1 big rectangle" is equal to the perimeter of the base.

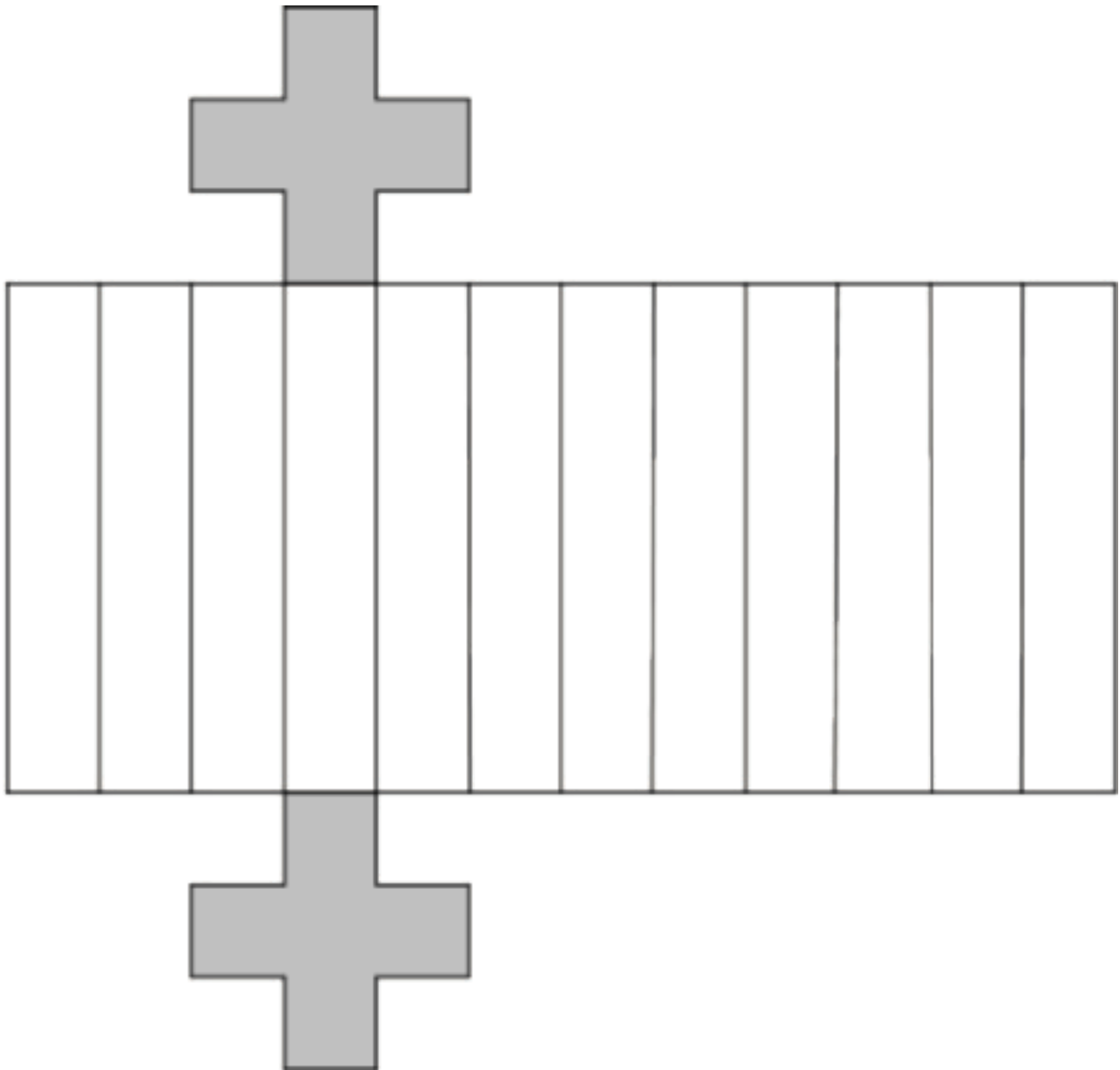

Students may have trouble generalizing which method would work for any prism. Here are some guiding questions:

- "Which of the students' methods will work for finding the surface area of this particular prism?" (all 3)

- “Which of the students’ methods will work for finding the surface area of any prism?” (Noah’s and Andre’s)
- “Which of the students’ methods will work for finding the surface area of other three-dimensional figures that are not prisms?” (only Noah’s)

If not mentioned by students, be sure students understand:

- Noah’s method will always work, but it can be inefficient if there are a lot of faces.
- Elena’s method will not always work because the rectangles will not always be the same size, but we can notice that some shapes are the same and not have to work them all out individually.
- Andre’s method does always work even if the rectangles have different widths. The length of the rectangle will be the same as the perimeter of the base and the width of the rectangle will be the height of the prism.
- Prisms can always be cut into three pieces: two bases and one rectangle whose length is the perimeter of a base and whose width is the height of the prism. This can be more efficient than the other methods because students only need to calculate two areas (since the two bases will be identical copies).
- This method only works for prisms. For other shapes, such as pyramids, Noah’s method of finding all the faces individually or Elena’s method of combining those faces into identical copy groups will work. Solids with holes, such as the triangular prism with a square hole, can use a variation on Elena’s method: two congruent triangles with holes for the bases, one rectangle for the outside side faces, and another rectangle for the faces forming the hole.

Explain to students that they will have the opportunity in the next activity to practice using any of these strategies.

Access for English Language Learners

Writing, Listening, Conversing: MLR1 Stronger and Clearer Each Time. Use this routine to help students improve a written responses to the question, “How big is the ‘1 large rectangle’ Andre is talking about?” Give students time to meet with 2–3 partners, to share and get feedback on their responses.

Provide students with prompts for feedback that will help their partners strengthen their ideas and clarify their language (e.g., “Can you draw a picture to support your explanation?”, “You should expand on...”, “How does that match with Andre’s thinking?”, etc.). Invite students to go back and revise or refine their written explanation based on their peer feedback. These conversations will help students make sense of the different methods for calculating the surface area of a figure.

Design Principle(s): Cultivate conversation; Optimize output (for explanation)

14.3 Revisiting a Pentagonal Prism

15 minutes

In this activity, students are presented with a figure that was used in a previous lesson to explore volume. Here, they explore its surface area and compare different methods from the previous task. Students work with a partner to share the task of investigating two methods to calculate the surface area.

As students work on the task, listen for students who find similarities and differences between the method they used and the one their partner used.

Addressing

- 7.G.B.6

Instructional Routines

- MLR8: Discussion Supports

Launch

Arrange students in groups of 2. Tell students that they might recognize this figure from a previous lesson, but today they are going to compare two different methods for calculating its surface area. Give students 1–2 minutes of quiet work time followed by time to trade their work with a partner to compare answers and methods. Follow with a whole-class discussion.

Access for Students with Disabilities

Representation: Internalize Comprehension. Activate or supply background knowledge about the surface area of a pentagonal prism by calculating area of all the faces and then using the perimeter of the the base. Allow students to use calculators to ensure inclusive participation in the activity.

Supports accessibility for: Memory; Conceptual processing

Access for English Language Learners

Speaking: MLR8 Discussion Supports. Use this routine to support students as they describe their strategy for calculating the area of the prism using one of the two methods. Provide sentence frames for students to use such as: “First I _____. Then I _____, because . . .” or “I decomposed (or unfolded) _____ to find . . .” Encourage students to consider what details are important to share, and to think about how they will explain their reasoning using mathematical language.

Design Principle(s): Optimize output (for explanation); Cultivate conversation

Student Task Statement

1. Between you and your partner, choose who will use each of these two methods to find the surface area of the prism.
 - Adding the areas of all the faces
 - Using the perimeter of the base.
2. Use your chosen method to calculate the surface area of the prism. Show your thinking. Organize it so it can be followed by others.

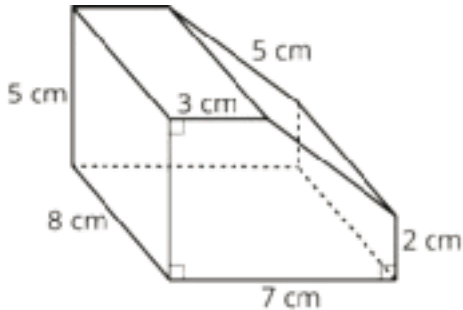

3. Trade papers with your partner, and check their work. Discuss your thinking. If you disagree, work to reach an agreement.

Student Response

1. No answer required.
2. The surface area is 234 cm^2 . Explanations vary. Sample responses:
 - Adding the areas of all the faces: There are two pentagonal bases that can each be decomposed into two rectangles (3 cm by 5 cm, and 4 cm by 2 cm) and a right triangle (base 4 cm and height 3 cm). Each pentagon has an area of 29 cm^2 , since $15 + 8 + 6 = 29$. There are five rectangular faces, each with a side that is 8 cm. Their combined area is 176 cm^2 , since $(3 \cdot 8) + (5 \cdot 8) + (7 \cdot 8) + (2 \cdot 8) + (5 \cdot 8) = 24 + 40 + 56 + 16 + 40 = 176$. The sum of the areas of the bases and the rectangles is 234 cm^2 , since $2(29) + 176 = 58 + 176 = 234$.
 - Using the perimeter of the base: There are two pentagonal bases that have an area of 29 cm^2 , since $15 + 8 + 6 = 29$. The perimeter of the pentagonal base is 22 cm, since $2 + 5 + 3 + 5 + 7 = 22$. All the rectangular faces, if unfolded, make a long rectangle that is 22 cm by 8 cm, so its area is 176 cm^2 , $22 \cdot 8 = 176$. The sum of the areas of the two bases and the long rectangle is 234 cm^2 , since $2(29) + 176 = 58 + 176 = 234$.

Are You Ready for More?



In a deck of cards, each card measures 6 cm by 9 cm.

1. When stacked, the deck is 2 cm tall, as shown in the first photo. Find the volume of this deck of cards.
2. Then the cards are fanned out, as shown in the second picture. The distance from the rightmost point on the bottom card to the rightmost point on the top card is now 7 cm instead of 2 cm. Find the volume of the new stack.

Student Response

1. 108 cm^3
2. 108 cm^3

Activity Synthesis

Select previously identified students to share the discussion they had with their partner. To highlight the difference between the two methods, ask:

- “How did you find the area of the base?”
- “How did you find any other areas you needed to solve the problem?”
- “How many different shapes did you need to calculate the area of when using the first method (calculating area of all the faces)?”
- “How many different shapes did you need to calculate the area of when using the second method (using perimeter of base)?”
- “Which method do you prefer for this problem? Why?”
- “Do you think you will prefer the same method for every problem? Why or why not?”
- “What would make you change methods?”
- “Do you need to know all of the measurements in the picture to solve for surface area?” (No, you just need to know the perimeter and area of the base and the height of the figure.)

- “Could you solve for volume with the measurements given in the picture? If so, are there any unnecessary measurements? If not, what else would you need to know?”

If not brought up in students’ explanations, explain to students that the first method requires finding the area of 6 different shapes (there are 7 faces, but the two bases are the same). While the calculations using this method were simple, there were more pieces. The second method requires visualizing the solid in a different way, but we only needed to find the area of two different pieces (the long rectangle and base).

Lesson Synthesis

- “What is surface area?” (The total area of all the exposed faces of an object.)
- “What are some methods for calculating surface area of prisms?” (Find the area of each face and add them for the total. Find groups of faces that have the same area and save some computation. Find the area of the bases and add that to the area of a “long rectangle.”)

14.4 Surface Area of a Hexagonal Prism

Cool Down: 5 minutes

Addressing

- 7.G.B.6

Student Task Statement

Find the surface area of this prism. Show your reasoning. Organize it so it can be followed by others.

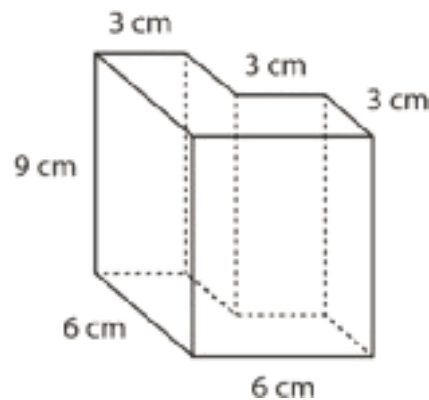

Student Response

The surface area is 270 cm^2 . Possible strategy: The area of the base is 27 cm^2 . The perimeter of the base is 24 cm , so the combined area of the sides is 216 cm^2 , because $24 \cdot 9 = 216$. Therefore the total surface area is 270 cm^2 , because $27 \cdot 2 + 216 = 270$.

Student Lesson Summary

To find the surface area of a three-dimensional figure whose faces are made up of polygons, we can find the area of each face, and add them up!

Sometimes there are ways to simplify our work. For example, all of the faces of a cube with side length s are the same. We can find the area of one face, and multiply by 6. Since the area of one face of a cube is s^2 , the surface area of a cube is $6s^2$.

We can use this technique to make it faster to find the surface area of any figure that has faces that are the same.

For prisms, there is another way. We can treat the prism as having three parts: two identical bases, and one long rectangle that has been taped along the edges of the bases. The rectangle has the same height as the prism, and its width is the perimeter of the base. To find the surface area, add the area of this rectangle to the areas of the two bases.

Glossary

- surface area

Lesson 14 Practice Problems

Problem 1

Statement

Edge lengths are given in units. Find the surface area of each prism in square units.

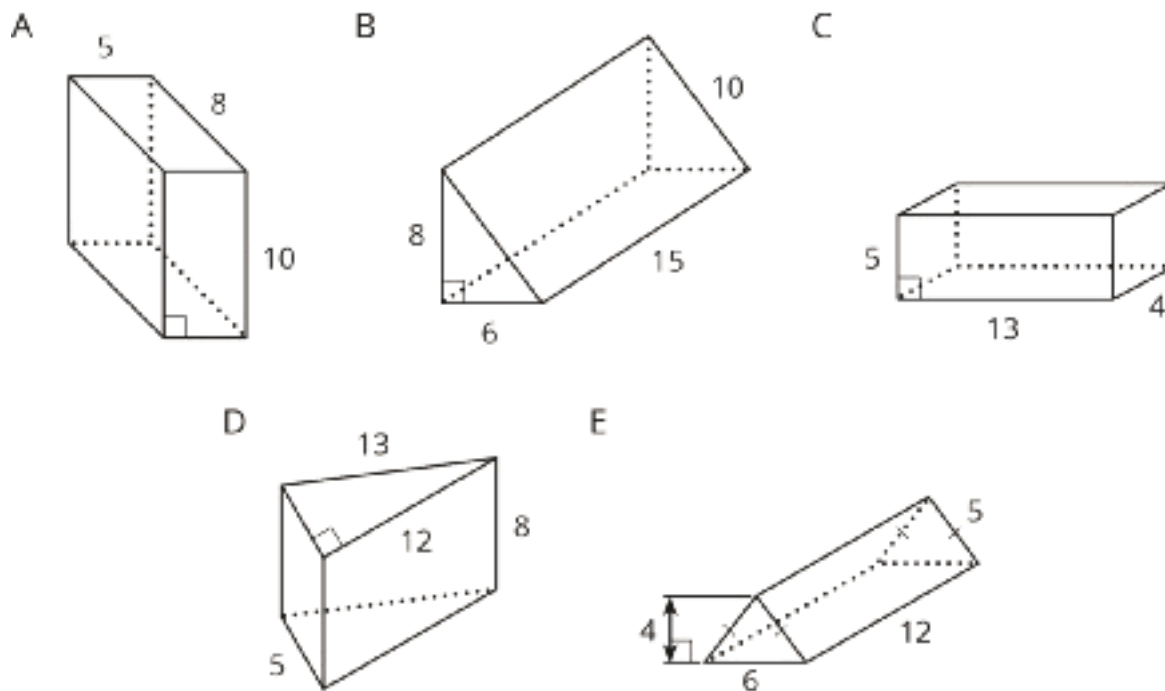

Solution

- a. 340
- b. 408
- c. 274
- d. 300
- e. 216

Problem 2

Statement

Priya says, "No matter which way you slice this rectangular prism, the cross section will be a rectangle." Mai says, "I'm not so sure." Describe a slice that Mai might be thinking of.



Solution

If you keep your slices parallel to a set of faces, then the cross section does have to be a rectangle. But if you can slice in any direction, you can get a triangle. Imagine slicing off one small corner of the prism.

(From Unit 7, Lesson 11.)

Problem 3

Statement

B is the intersection of line AC and line ED . Find the measure of each of the angles.

- Angle ABF
- Angle ABD
- Angle EBC
- Angle FBC
- Angle DBG

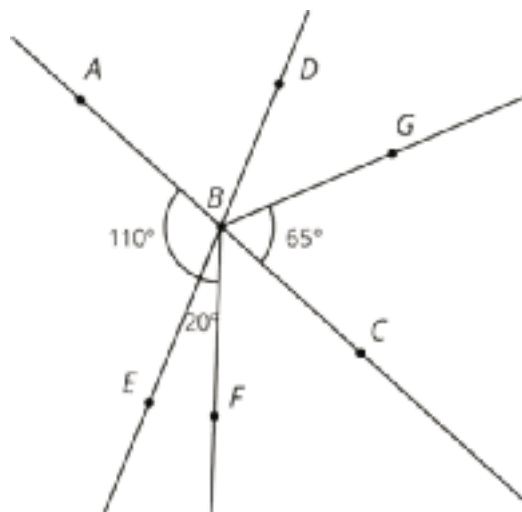

Solution

- 130 degrees (sum of angles ABE and EBF)
- 70 degrees (supplementary with angle ABE)
- 70 degrees (vertical with ABD)
- 50 degrees (subtract the measure of angle EBF from the measure of angle EBC)
- 45 degrees (subtract the measures of angles ABD and CBG from 180°)

(From Unit 7, Lesson 5.)

Problem 4

Statement

Write each expression with fewer terms.

a. $12m - 4m$

b. $12m - 5k + m$

c. $9m + k - (3m - 2k)$

Solution

a. $8m$

b. $13m - 5k$

c. $6m + 3k$

(From Unit 6, Lesson 20.)

Problem 5

Statement

a. Find 44% of 625 using the facts that 40% of 625 is 250 and 4% of 625 is 25.

b. What is 4.4% of 625?

c. What is 0.44% of 625?

Solution

a. 275 (Because 44% of a number equals 40% of the number plus an additional 4% of the number)

b. 27.5

c. 2.75

(From Unit 4, Lesson 9.)

Lesson 15: Distinguishing Volume and Surface Area

Goals

- Compare and contrast (orally and in writing) problems that involve surface area and volume of prisms.
- Decide whether to calculate the surface area or volume of a prism to solve a problem in a real-world situation, and justify (orally) the decision.
- Estimate measurements of a prism in a real-world situation, and explain (orally) the estimation strategy.

Learning Targets

- I can decide whether I need to find the surface area or volume when solving a problem about a real-world situation.

Lesson Narrative

This is the first of two lessons where students apply their knowledge of surface area and volume to solve real-world problems. The purpose of this first lesson is to help students distinguish between surface area and volume and to choose which of the two quantities is appropriate for solving a problem. They solve problems that require finding the surface area or volume of a prism, or both. When they choose whether to use surface area or volume, they are choosing a mathematical model for the situation and engaging in MP4.

Alignments

Addressing

- 7.G.B: Solve real-life and mathematical problems involving angle measure, area, surface area, and volume.
- 7.G.B.6: Solve real-world and mathematical problems involving area, volume and surface area of two- and three-dimensional objects composed of triangles, quadrilaterals, polygons, cubes, and right prisms.

Instructional Routines

- MLR7: Compare and Connect
- MLR8: Discussion Supports
- Poll the Class

Required Materials

Pre-printed slips, cut from copies of the

Instructional master

Required Preparation

Make 1 copy of the Card Sort: Surface Area or Volume Instructional master for every 2 students, and cut them up ahead of time.

Student Learning Goals

Let's work with surface area and volume in context.

15.1 The Science Fair

Warm Up: 5 minutes

The purpose of this warm-up is for students to reason about two objects that have the same volume but different surface areas within a context.

Addressing

- 7.G.B.6

Instructional Routines

- Poll the Class

Launch

Give students 1 minute of quiet think time followed by a whole-class discussion.

Student Task Statement

Mai's science teacher told her that when there is more ice touching the water in a glass, the ice melts faster. She wants to test this statement so she designs her science fair project to determine if crushed ice or ice cubes will melt faster in a drink.

She begins with two cups of warm water. In one cup, she puts a cube of ice. In a second cup, she puts crushed ice with the same volume as the cube. What is your hypothesis? Will the ice cube or crushed ice melt faster, or will they melt at the same rate? Explain your reasoning.

Student Response

The crushed ice will melt faster because there are more parts touching the warm water. The increased surface area will make the crushed ice melt faster.

Activity Synthesis

Poll the students on their hypotheses. Record and display their responses for all to see. If all students agree the crushed ice will melt the fastest, ask them to share their reasoning. If there are different hypotheses, ask students to explain their choice and ask questions of one another. Continue the discussion until the students reach an agreement on the crushed ice. Important ideas to highlight during the discussion are:

- Since the crushed ice has more places touching the warm water, it should melt faster.
- The center of the cube is surrounded by cold ice and will not melt until it is touching the water.

- The *surface area* of the crushed ice is greater, so it will melt faster than the ice cube even though they have the same volume.

If any of these ideas are not mentioned by students, bring them to their attention at the end of the discussion.

15.2 Revisiting the Box of Chocolates

10 minutes

In this activity students are presented with a prism that was used in a previous lesson to calculate volume. Here, they calculate the surface area of the prism. This provides students with the opportunity to work with complex shapes to find surface area in a given context.

Addressing

- 7.G.B.6

Instructional Routines

- MLR7: Compare and Connect

Launch

Display the image for all to see throughout the activity. Tell students that they calculated the volume of this heart-shaped box in a previous lesson and today they are going to calculate a different measurement. Ask students what additional information they need to find the total amount of cardboard in the box. When students recognize that they need the lengths of the diagonal sides of the box give them the measurements for those sides (2.2 inches for the sides around the top and 6.4 inches for the sides around the bottom). Give students 2–3 minutes of quiet work time followed by a whole-class discussion.



Access for Students with Disabilities

Representation: Internalize Comprehension. Activate or supply background knowledge by reviewing the heart-shaped box volume calculations. Allow students to use calculators to ensure inclusive participation in the activity.

Supports accessibility for: Memory; Conceptual processing

Anticipated Misconceptions

Students who are familiar with actual heart-shaped boxes of chocolate may want to double the lateral area to represent the way the top and bottom pieces nest together.

Student Task Statement

The other day, you calculated the volume of this heart-shaped box of chocolates.

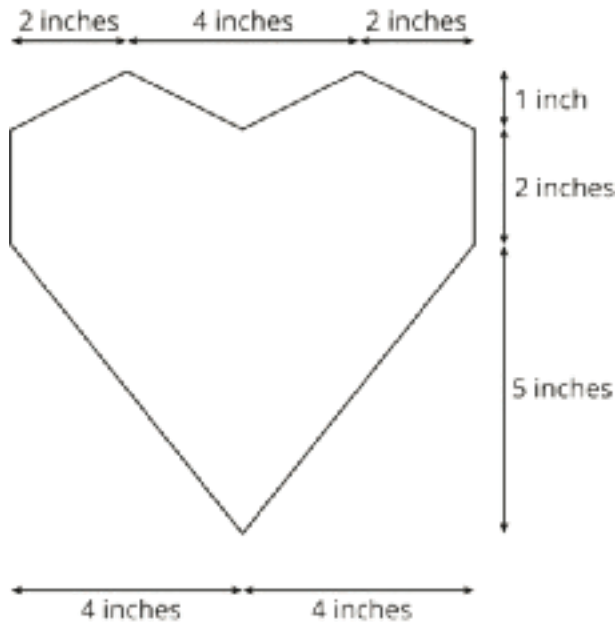

The depth of the box is 2 inches. How much cardboard is needed to create the box?

Student Response

131.2 in^2 . The area of the heart base is 40 in^2 as we solved the other day. The perimeter of the base is 25.6 in , so the area of the long rectangle of the prism is 51.2 in^2 , because $25.6 \cdot 2 = 51.2$. Therefore, the total surface area is found with $40 + 40 + 51.2 = 131.2$.

Activity Synthesis

Select students to share their solutions and methods for calculating the surface area. Consider asking some of the following questions:

- "How did you figure out that you had to calculate the surface area of the box?"

- “What method did you use to calculate the surface area?”
- “If the candy maker wants to make a set of two boxes that are each half of a heart and could be put together to make a box that looks like this one, would the total amount of cardboard used to make the two boxes be different than making the one box?” (Yes, it would increase.)
- “How could the candy maker reduce the surface area of the one box without reducing the volume?” (If he made it a triangle or some other shape with fewer segments instead of a heart.)

Access for English Language Learners

Representing, Conversing: MLR7 Compare and Connect. Use this routine to help students consider audience when preparing a visual display of their work. Ask students to prepare a visual display that shows how they calculated the surface area of the box. Students should consider how to display their calculations so that another student can interpret them. Some students may wish to add notes or details to their drawings to help communicate their thinking. Invite students exchange their displays with 2–3 other students, to review and compare their calculations. These exchanges strengthen students' mathematical language use and reasoning related to surface area.

Design Principle(s): Cultivate conversation; Maximize meta-awareness

15.3 Card Sort: Surface Area or Volume

15 minutes

The purpose of this activity is for students to sort cards with questions that have a context referring to either volume or surface area of a prism. In previous lessons, students focused on determining volume or surface area and the two concepts were never presented side by side. Here, students are asked to sort questions with a context to determine if it makes more sense to think about surface area or volume when answering the question. After sorting, students think about what information they need to answer a question and estimate reasonable measurements to calculate the answer to their question (MP2).

Addressing

- 7.G.B.6

Instructional Routines

- MLR7: Compare and Connect

Launch

Arrange students in groups of 2. Distribute pre-printed slips, cut from copies of the Instructional master. Give groups 2–3 minutes of quiet work time. Once each group has sorted their cards, poll

the class as to where they placed each card. Display the answers for all to see for the rest of the activity. Ask students to come to agreement on any differences.

After the class has come to agreement on the sorted cards, students can either choose one card or be assigned a specific card to examine further. Give students 2–3 minutes of quiet work time to complete the rest of the task followed by time to discuss their work with a partner. Follow with a whole-class discussion.

Access for Students with Disabilities

Engagement: Develop Effort and Persistence. Encourage and support opportunities for peer interactions. Invite students to talk about their ideas with a partner before writing them down. Display sentence frames to support students when they explain their strategy. For example, “I noticed ____ so I knew it was ...”.

Supports accessibility for: Language; Social-emotional skills

Student Task Statement

Your teacher will give you cards with different figures and questions on them.

1. Sort the cards into two groups based on whether it would make more sense to think about the surface area or the volume of the figure when answering the question. Pause here so your teacher can review your work.
2. Your teacher will assign you a card to examine more closely. What additional information would you need to be able to answer the question on your card?
3. Estimate reasonable measurements for the figure on your card.
4. Use your estimated measurements to calculate the answer to the question.

Student Response

The first three cards in the first column of Instructional master are volume, the rest of the cards refer to surface area.

Are You Ready for More?

A cake is shaped like a square prism. The top is 20 centimeters on each side, and the cake is 10 centimeters tall. It has frosting on the sides and on the top, and a single candle on the top at the exact center of the square. You have a knife and a 20-centimeter ruler.

1. Find a way to cut the cake into 4 fair portions, so that all 4 portions have the same amount of cake and frosting.
2. Find another way to cut the cake into 4 fair portions.
3. Find a way to cut the cake into 5 fair portions.

Student Response

1. The simplest way is to cut the cake in half on one diagonal, and then on the other diagonal.
2. The key is to pick points that are equally spaced from the corners, as shown.
3. The perimeter of the cake is 80 cm, and $80 \div 5 = 16$. Find 5 points around the perimeter of the cake that are each 16 centimeters apart, and connect each of them to the candle in the center with a cut. Each piece gets 16 cm of the edge of the cake, so the same amount of frosting. Through decomposing into triangles, we can show that each piece of the cake has a volume of 800 cubic centimeters. (Note that this solution presumes that the frosting has no thickness, which is not likely to be true, but is a handy simplifying assumption. In reality, people who love frosting should still take a corner piece.)

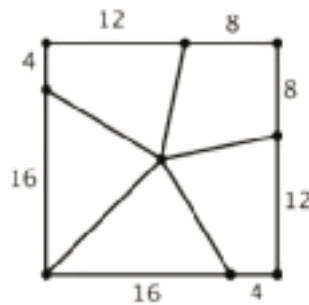

Activity Synthesis

Select students to share their explanations of how they determined if a question reference volume or surface area. To highlight the differences and similarities ask students:

- “How do you know volume is being asked about in that question?”
- “How do you know surface area is being asked about in that question?”

The goal is to ensure students can verbally describe their reasoning because they are asked to write about the similarities and differences in the cool down. You may wish to refer back to the poll responses collected in the middle of the activity.

Invite students to share the measurements they came up with and how they calculated an answer to their question. Ask other students who had the same question but used different measurements to share and compare the reasonableness of each answer.

Consider asking some of the following questions:

- “How did you determine which information you needed to answer the question? What information might not be needed?”
 - “How did you decide on the exact measurements to use?”
 - “What is different about the measurements used in these questions?”
 - “Do they all make sense?”
 - “Are there other measurements that could have been used?”
-

Access for English Language Learners

Representing, Speaking, and Listening: MLR7 Compare and Connect. Use this routine when students share their strategies for determining whether the question referenced volume or surface area. Ask students to consider what is the same and what is different about each approach. Draw students’ attention to the relationship between the language of the question and whether the problem examines volume or surface area. These exchanges can strengthen students’ mathematical language use and reasoning based on volume and surface area.

Design Principle(s): Maximize meta-awareness; Support sense-making

15.4 A Wheelbarrow of Concrete

Optional: 5 minutes

This optional activity reinforces work students have done in previous activities with regards to surface area and volume. Students work with a contextual problem to determine the surface area and volume of an object.

Addressing

- 7.G.B.6

Instructional Routines

- MLR8: Discussion Supports

Launch

Arrange students in groups of 2. If desired, display the image of a wheelbarrow for all to see.



Give students 1–2 minutes of quiet work time followed by time to discuss their answers with their partner. Follow with a whole-class discussion.

Student Task Statement

A wheelbarrow is being used to carry wet concrete. Here are its dimensions.

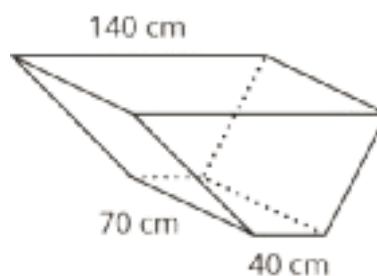
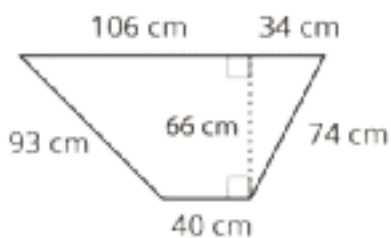

1. What volume of concrete would it take to fill the tray?
2. After dumping the wet concrete, you notice that a thin film is left on the inside of the tray. What is the area of the concrete coating the tray? (Remember, there is no top.)

Student Response

1. The volume is $415,800 \text{ cm}^3$. The area of the base is $5,940 \text{ cm}^2$ and can be found by cutting it into two triangles and a rectangle, because $40 \cdot 66 + \frac{1}{2} \cdot 34 \cdot 66 + \frac{1}{2} \cdot 66 \cdot 66 = 5,940$. So, the volume is $415,800 \text{ cm}^3$, because $5,940 \cdot 70 = 415,800$.
2. The surface area inside the wheelbarrow is $26,370 \text{ cm}^2$. The perimeter of the base is 347 cm, but there is no top to the wheelbarrow, so we only need a length of 207 cm for the long rectangle, because $347 - 106 - 34 = 207$. So the area of the long rectangular side should be $14,490 \text{ cm}^2$, because $207 \cdot 70 = 14,490$. So, the total area is the area of the bases added to the area of the long rectangle. $5,940 + 5,940 + 14,490 = 26,370$.

Activity Synthesis

Reveal the solution to each problem and give students a few minutes to resolve any discrepancies with their partners.

Access for English Language Learners

Speaking: MLR8 Discussion Supports. Use this routine to scaffold students as they discuss their strategies and solutions for calculating the volume of concrete in and surface area of the wheelbarrow. Provide sentence frames for students to use with their partner, such as: “First I _____. Then I _____, because . . .” and “The volume is _____ because . . .” Encourage students to consider what details are important to share and to think about how they will explain their reasoning using mathematical language.

Design Principle(s): Optimize output (for explanation); Cultivate conversation

Lesson Synthesis

- “When is it better to know surface area than volume?” (When you are covering an object, when you want to know how much is exposed to the environment, etc.)
- “When is it better to know volume than surface area?” (When you are filling up the object, when you need to know how much is already inside, etc.)
- “If you cut an object in half, how does that affect the volume and surface area?” (The volume remains unchanged, but the surface area will increase.)

15.5 Surface Area Differences

Cool Down: 5 minutes

Addressing

- 7.G.B

Student Task Statement

Describe some similarities and differences between a situation that involves calculating surface area and a situation that involves calculating volume.

Student Response

Answers vary. Sample response: Volume refers to how much of something fits inside an object. Surface area refers to how much of something is needed to cover the outside of an object.

Student Lesson Summary

Sometimes we need to find the volume of a prism, and sometimes we need to find the surface area.



Here are some examples of quantities related to volume:

- How much water a container can hold
- How much material it took to build a solid object

Volume is measured in cubic units, like in^3 or m^3 .

Here are some examples of quantities related to surface area:

- How much fabric is needed to cover a surface
- How much of an object needs to be painted

Surface area is measured in square units, like in^2 or m^2 .

Lesson 15 Practice Problems

Problem 1

Statement

Here is the base of a prism.

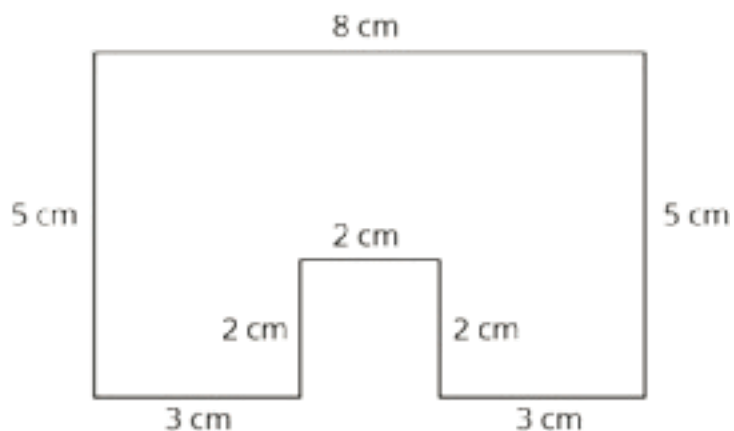

- If the height of the prism is 5 cm, what is its surface area? What is its volume?
- If the height of the prism is 10 cm, what is its surface area? What is its volume?
- When the height doubled, what was the percent increase for the surface area? For the volume?

Solution

a. $SA = 222 \text{ cm}^2$, $V = 180 \text{ cm}^3$

b. $SA = 372 \text{ cm}^2$, $V = 360 \text{ cm}^3$

- c. The surface area increased by about 67.6%. The volume increased by 100% (doubled).

Problem 2

Statement

Select **all** the situations where knowing the volume of an object would be more useful than knowing its surface area.

- A. Determining the amount of paint needed to paint a barn.
- B. Determining the monetary value of a piece of gold jewelry.
- C. Filling an aquarium with buckets of water.
- D. Deciding how much wrapping paper a gift will need.
- E. Packing a box with watermelons for shipping.
- F. Charging a company for ad space on your race car.
- G. Measuring the amount of gasoline left in the tank of a tractor.

Solution

["B", "C", "E", "G"]

Problem 3

Statement

Han draws a triangle with a 50° angle, a 40° angle, and a side of length 4 cm as shown. Can you draw a different triangle with the same conditions?

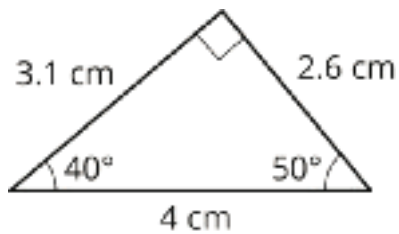

Solution

Answers vary. Sample response: Yes, if we rearrange the angles and side, there are more possibilities.

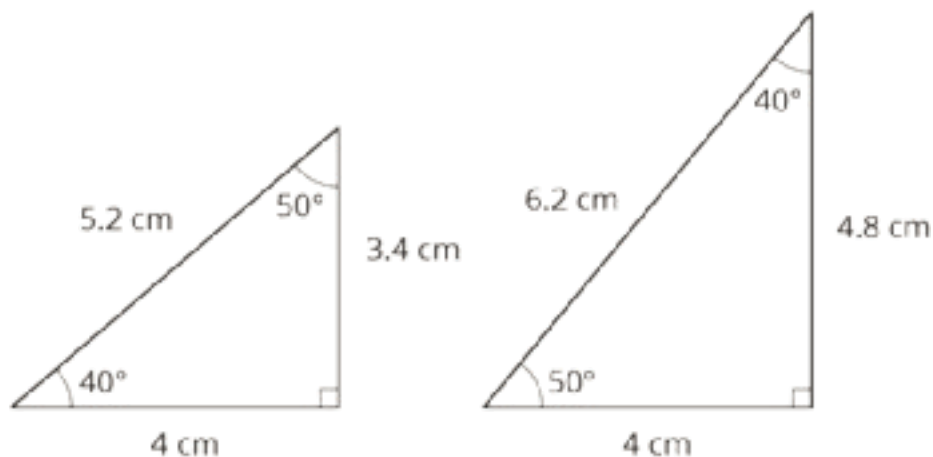

(From Unit 7, Lesson 9.)

Problem 4

Statement

Angle H is half as large as angle J . Angle J is one fourth as large as angle K . Angle K has measure 240 degrees. What is the measure of angle H ?

Solution

30°

(From Unit 7, Lesson 3.)

Problem 5

Statement

The Colorado state flag consists of three horizontal stripes of equal height. The side lengths of the flag are in the ratio 2 : 3. The diameter of the gold-colored disk is equal to the height of the center stripe. What percentage of the flag is gold?



Solution

Approximately 5.82% (the exact proportion is $\frac{\pi}{54}$ or equivalent)

(From Unit 4, Lesson 9.)

Lesson 16: Applying Volume and Surface Area

Goals

- Apply reasoning about surface area and volume of prisms as well as proportional relationships to calculate how much the material to build something will cost, and explain (orally and in writing) the solution method.

Learning Targets

- I can solve problems involving the volume and surface area of children's play structures.

Lesson Narrative

In this second lesson on applying surface area and volume to solve problems, students solve more complex real-world problems that require them to choose which of the two quantities is appropriate for solving the problem, or whether both are appropriate for different aspects of the problem. They use previous work on ratios and proportional relationships, thus consolidating their knowledge and skill in that area. When students bring together knowledge of different areas of mathematics to solve a complex problem, they are engaging in MP4.

Alignments

Addressing

- 7.G.B: Solve real-life and mathematical problems involving angle measure, area, surface area, and volume.
- 7.G.B.6: Solve real-world and mathematical problems involving area, volume and surface area of two- and three-dimensional objects composed of triangles, quadrilaterals, polygons, cubes, and right prisms.
- 7.RP.A: Analyze proportional relationships and use them to solve real-world and mathematical problems.

Instructional Routines

- MLR3: Clarify, Critique, Correct
- MLR7: Compare and Connect

Student Learning Goals

Let's explore things that are proportional to volume or surface area.

16.1 You Decide

Warm Up: 5 minutes

This activity reinforces what students learned in the previous lesson. Students are given two contextual situations and determine if the situation requires surface area or volume to be calculated.

Addressing

- 7.G.B

Launch

Arrange students in groups of 2. Give students 1 minute of quiet work time followed by time to discuss their reasoning with a partner. Follow with a whole-class discussion.

Student Task Statement

For each situation, decide if it requires Noah to calculate surface area or volume. Explain your reasoning.

1. Noah is planning to paint the bird house he built. He is unsure if he has enough paint.
2. Noah is planning to use a box with a trapezoid base to hold modeling clay. He is unsure if the clay will all fit in the box.

Student Response

1. Surface area. The surface area is what Noah will calculate because he would need to calculate how much area he needs to cover on the surface of the bird house.
2. Volume. The volume is what Noah will calculate because he needs to calculate how much space the box has inside of it to determine if it will hold all of his clay.

Activity Synthesis

Select students to share their responses. Ask students to describe why the bird house situation calls for surface area and why the clay context calls for volume. To highlight the differences between the two uses of the box, ask:

- “What are the differences in how Noah is using the boxes in these situations?”
- “How can you determine if a situation is asking you to calculate surface area or volume?”

The goal is to ensure students understand the differences between situations that require them to calculate surface area and volume.

16.2 Foam Play Structure

15 minutes

In this activity, students apply what they have learned previously about surface area and volume to different situations (MP4). Students have to consider whether they are finding the surface area or volume before answering each question. In addition, students apply proportional reasoning to find the cost of the vinyl that is needed. This is an opportunity for students to revisit this prior understanding in a geometry context.

As students work on the task, monitor for students who are using different methods to decompose or compose the base of the object to calculate the area.

Addressing

- 7.G.B.6
- 7.RP.A

Instructional Routines

- MLR7: Compare and Connect

Launch

Arrange students in groups of 2. Make sure students are familiar with the terms “foam” and “vinyl.” For example, it may help to explain that many binders are made out of cardboard covered with vinyl. In the diagram, all measurements have been rounded to the nearest inch.

Give students 3–5 minutes of quiet work time followed by time to share their answers with a partner. Follow with a whole-class discussion.

Access for Students with Disabilities

Representation: Internalize Comprehension. Activate or supply background knowledge by reviewing an image or video of a foam play structure. Allow students to use calculators to ensure inclusive participation in the activity.

Supports accessibility for: Memory; Conceptual processing

Anticipated Misconceptions

For the first question, students may try to figure out the total mass of foam needed instead of the total volume. Point out that they are not given any information about how much the foam weighs and prompt them to look for a different way of answering the question “how much foam?”

Some students might see the 0.8¢ for the unit price and confuse that with \$0.80. Remind students of their work with fractional percentages in a previous unit and that 0.8¢ must be less than 1¢.

Student Task Statement

At a daycare, Kiran sees children climbing on this foam play structure.

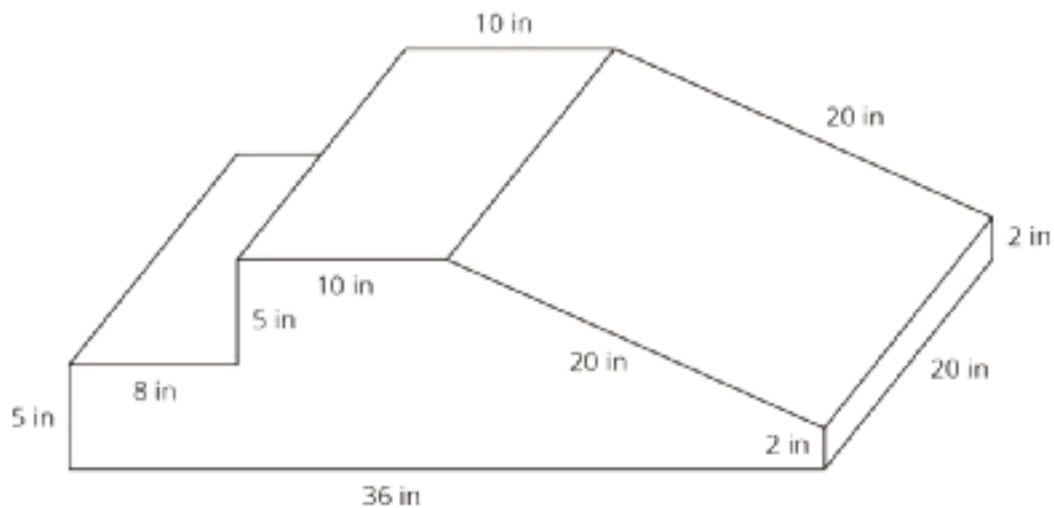

Kiran is thinking about building a structure like this for his younger cousins to play on.

1. The entire structure is made out of soft foam so the children don't hurt themselves. How much foam would Kiran need to build this play structure?
2. The entire structure is covered with vinyl so it is easy to wipe clean. How much vinyl would Kiran need to build this play structure?
3. The foam costs 0.8¢ per in^3 . Here is a table that lists the costs for different amounts of vinyl. What is the total cost for all the foam and vinyl needed to build this play structure?

| vinyl (in^2) | cost (\$) |
|-------------------------|-----------|
| 75 | 0.45 |
| 125 | 0.75 |

Student Response

1. The volume of the play structure is $4,960 \text{ in}^3$, because the area of the base is 248 in^2 and $248 \cdot 20 = 4,960$. Possible strategy:

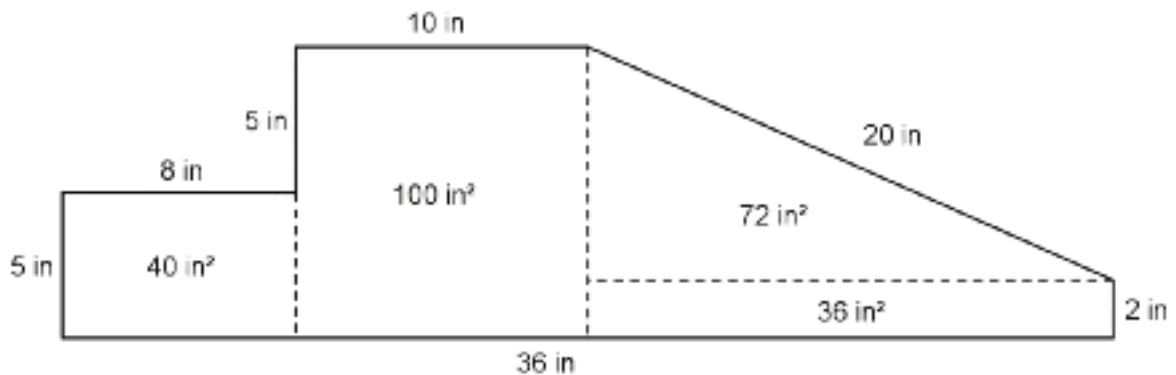

- The surface area of the play structure is $2,216 \text{ in}^2$, because the perimeter of the base is 86 in and $86 \cdot 20 + 248 \cdot 2 = 2,216$.
- The total cost is \$52.98. The foam will cost \$39.68 because $4,960 \cdot 0.008 = 39.68$. The vinyl will cost \$13.30, because $2,216 \cdot 0.006 = 13.296$. The total cost is \$52.98, because $39.68 + 13.30 = 52.98$.

Are You Ready for More?

When he examines the play structure more closely, Kiran realizes it is really two separate pieces that are next to each other.

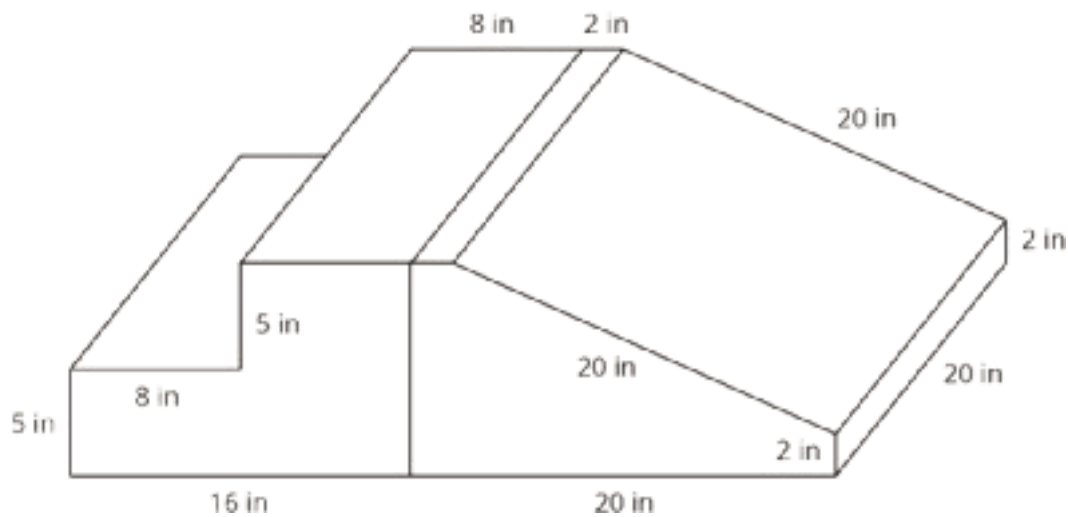

- How does this affect the amount of foam in the play structure?
- How does this affect the amount of vinyl covering the play structure?

Student Response

- The volume of foam stays the same.
- The surface area increases by 400 in^2 , because there are two new faces, each with an area of $20 \cdot 10$, or 200 in^2 .

Activity Synthesis

Select previously identified students to share how they calculated the area of the base.

Consider asking some of the following questions:

- “Are there other ways to calculate the area of the base?”
- “How did you know if you had to calculate surface area or volume for this problem?”
- “If Kiran buys a big block of foam that is 36 inches wide, 20 inches deep, and 10 inches tall and cuts it into this shape, what shapes would he be cutting off?” (A rectangular prism for the step on the left side and a triangular prism for the slide part on the right.)

- “How much more would the big block of foam cost than your calculations?” (This method wastes a volume of $36 \cdot 20 \cdot 10 - 4,960 = 2,240$ cubic inches of foam. This would be an extra \$17.92 since $2,240 \cdot 0.008 = 17.92$.)
- If Kiran decides not to cover the bottom of the structure with vinyl, how much would he save?” (This reduces the area of vinyl needed by another $36 \cdot 20 = 720$ square inches. This would save \$4.32 since $720 \cdot 0.006 = 4.32$.)

Access for English Language Learners

Conversing, Listening: MLR7 Compare and Connect. Use this routine when students share their strategies for calculating the volume of the play structure. Ask students to consider what is the same and what is different about each approach. In this discussion, listen for and amplify comments that refer to the way the figure was decomposed. Draw students’ attention to the various ways area and perimeter of the base were found and how these were represented in each strategy. These exchanges can strengthen students’ mathematical language use and reasoning based on volume and surface area.

Design Principle(s): Maximize meta-awareness

16.3 Filling the Sandbox

10 minutes

This activity provides another opportunity for students to apply what they have previously learned about surface area and volume to different situations. Students will practice using proportions as they apply to volumes of prisms in a real-world application.

As students work on the task, monitor for students who use different strategies to answer the questions.

Addressing

- 7.G.B.6
- 7.RP.A

Instructional Routines

- MLR3: Clarify, Critique, Correct

Launch

Arrange students in groups of 2. If desired, have students close their books or devices and display this regular hexagon with the dimensions of the sandbox in the problem for all to see. Ask students to calculate the base area of the sandbox.

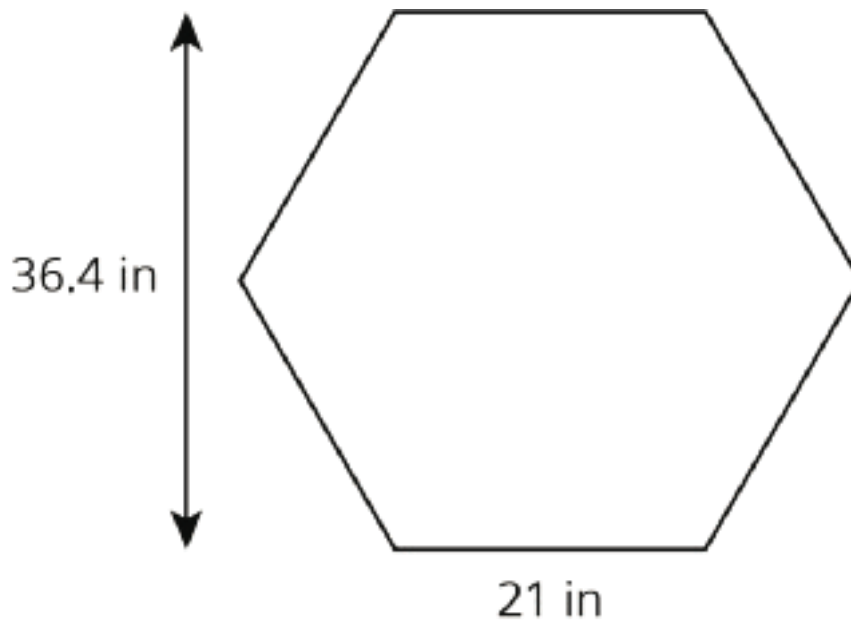

Give students 2–3 minutes of quiet work time followed by time to discuss their work with a partner. Follow with a whole-class discussion.

Access for Students with Disabilities

Action and Expression: Internalize Executive Functions. Chunk this task into more manageable parts to support students who benefit from support with organizational skills in problem solving. For example, present one question at a time.

Supports accessibility for: Organization; Attention

Anticipated Misconceptions

Students may think that Andre’s father needs to purchase 15 bags of sand, because they rounded their answers to 5 and 10 for the individual sandboxes and then added $5 + 10 = 15$. Point out to students that he could pour some of the sand from the same bag into both sandboxes.

Student Task Statement

The daycare has two sandboxes that are both prisms with regular hexagons as their bases. The smaller sandbox has a base area of $1,146 \text{ in}^2$ and is filled 10 inches deep with sand.

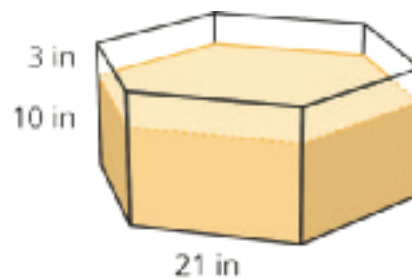

1. It took 14 bags of sand to fill the small sandbox to this depth. What volume of sand comes in one bag? (Round to the nearest whole cubic inch.)

2. The daycare manager wants to add 3 more inches to the depth of the sand in the small sandbox. How many bags of sand will they need to buy?
3. The daycare manager also wants to add 3 more inches to the depth of the sand in the large sandbox. The base of the large sandbox is a scaled copy of the base of the small sandbox, with a scale factor of 1.5. How many bags of sand will they need to buy for the large sandbox?
4. A lawn and garden store is selling 6 bags of sand for \$19.50. How much will they spend to buy all the new sand for both sandboxes?

Student Response

1. 819 cubic inches of sand. The volume of the sand that is already there is $11,460 \text{ in}^3$ since $1,146 \cdot 10 = 11,460$. Since 14 bags were used, each bag must have 819 cubic inches inside, because $11,460 \div 14 \approx 819$.
2. 5 bags of sand. One way to think about it is that it took 14 bags to fill it to a depth of 10 inches. To fill it another 3 inches, it will take $\frac{3}{10}$ as many bags as the previous time. Since we can't buy part of a bag, we round up to 5 bags, because $\frac{3}{10} \cdot 14 = 4.2$.
3. 10 bags of sand. One way to think about it is that the larger sandbox's dimensions are all multiplied by 1.5, so the area is multiplied by 2.25, because $1.5 \cdot 1.5 = 2.25$. Since the needed depth of sand is the same, the volume is also multiplied by 2.25, so $2.25 \cdot 4.2 = 9.45$.
4. \$45.50. Andre's father needs to purchase a total of 14 bags of sand, because $4.2 + 9.45 = 13.65$. At \$3.25 each, that would cost $14 \cdot 3.25$, or \$45.50.

Activity Synthesis

Select previously identified students to share their methods of solving the problem. Consider asking the following questions:

- "Are there any other ways to solve this problem?"
- "Did you use any answers from one question (or multiple questions) to help you answer another question? If so, why?"
- "Did you use volume or surface area to help you answer any questions?" (yes, volume)
- "How did you calculate how much the daycare would spend on sand?"

Access for English Language Learners

Writing: MLR3 Clarify, Critique, Correct. Present an incorrect statement that reflects a possible misunderstanding from the class for the number of bags Andre’s dad needs to purchase. For example, an incorrect statement is: “Andre’s dad needs to buy 15 sandbags because the small sandbox needs 5 bags and the larger sandbox needs 10 bags.” Prompt students to critique the solution (e.g., ask students, “Is this answer reasonable? Why or why not?”), and then write feedback to the author that identifies how to improve the solution and expand on his/her work. Listen for students who tie their feedback directly to the problem context (e.g., asking, “Why can’t one bag be used for both sandboxes?” or “How much sand will be left over?”) and use the language of volume, surface area, and perimeter. This will help students evaluate, and improve on, the written mathematical arguments of others and highlight the importance of context when solving problems.

Design Principle(s): Maximize meta-awareness

Lesson Synthesis

- “How do we use volume and surface area to solve more complex real-world problems?” (You may need to calculate volume or surface area to answer a bigger question like how much it would cost to build a toy.)
- “What other skills did you have to use to solve the problems in this lesson?” (ratios and proportional relationships)

Explain to students that many times in real-world problems calculating the volume or surface area is just a small piece of what is needed to be done. There are many other skills involved in solving more complex problems.

16.4 Preparing for the Play

Cool Down: 5 minutes

Addressing

- 7.G.B.6

Student Task Statement

Andre is preparing for the school play. He needs to paint a cardboard box to look like a dresser. The box is a rectangular prism that measures 5 feet tall, 4 feet long, and $2\frac{1}{2}$ feet wide. Andre does not need to paint the bottom of the box.

1. How much cardboard does Andre need to paint?
2. If one bottle of paint covers an area of 40 square feet, how many bottles of paint does Andre need to buy for this project?

Student Response

1. 75 square feet. $(2.5 \cdot 4) + 2(5 \cdot 4) + 2(2.5 \cdot 5) = 75$
2. 2 bottles of paint. $\frac{75}{40} = 1.875$

Student Lesson Summary

Suppose we wanted to make a concrete bench like the one shown in this picture. If we know that the finished bench has a volume of 10 ft^3 and a surface area of 44 ft^2 we can use this information to solve problems about the bench.



For example,

- How much does the bench weigh?
- How long does it take to wipe the whole bench clean?
- How much will the materials cost to build the bench and to paint it?

To figure out how much the bench weighs, we can use its volume, 10 ft^3 . Concrete weighs about 150 pounds per cubic foot, so this bench weighs about 1,500 pounds, because $10 \cdot 150 = 1,500$.

To figure out how long it takes to wipe the bench clean, we can use its surface area, 44 ft^2 . If it takes a person about 2 seconds per square foot to wipe a surface clean, then it would take about 88 seconds to clean this bench, because $44 \cdot 2 = 88$. It may take a little less than 88 seconds, since the surfaces where the bench is touching the ground do not need to be wiped.

Would you use the volume or the surface area of the bench to calculate the cost of the concrete needed to build this bench? And for the cost of the paint?

Lesson 16 Practice Problems

Problem 1

Statement

A landscape architect is designing a pool that has this top view:

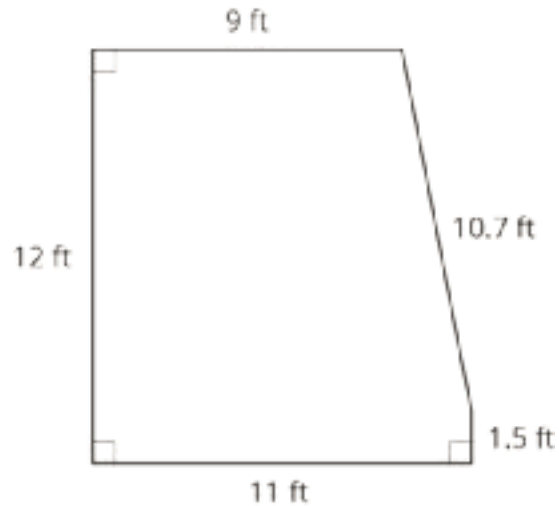

- How much water will be needed to fill this pool 4 feet deep?
- Before filling up the pool, it gets lined with a plastic liner. How much liner is needed for this pool?
- Here are the prices for different amounts of plastic liner. How much will all the plastic liner for the pool cost?

| plastic liner (ft ²) | cost (\$) |
|----------------------------------|-----------|
| 25 | 3.75 |
| 50 | 7.50 |
| 75 | 11.25 |

Solution

- 486 ft³
- 298.3 ft²
- \$44.75

Problem 2

Statement

Shade in a base of the trapezoidal prism. (The base is not the same as the bottom.)

- Find the area of the base you shaded.
- Find the volume of this trapezoidal prism.

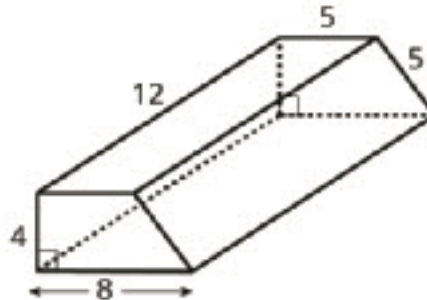

Solution

The bases of the prism are the two trapezoids. Students may shade either the trapezoid at the front or the trapezoid at the back.

- 26
- 312

(From Unit 7, Lesson 13.)

Problem 3

Statement

For each diagram, decide if y is an increase or a decrease of x . Then determine the percentage that x increased or decreased to result in y .

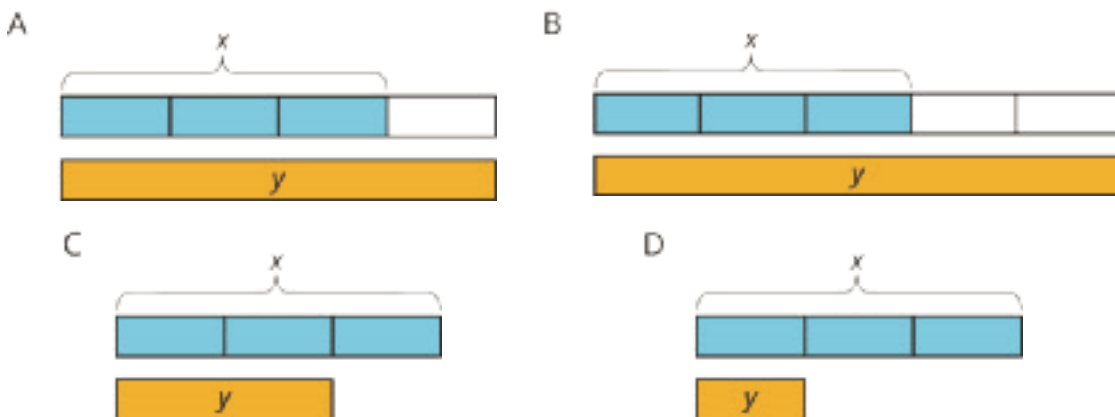

Solution

- Increase, $33\frac{1}{3}\%$

b. Increase, $66\frac{2}{3}\%$

c. Decrease, $33\frac{1}{3}\%$

d. Decrease, $66\frac{2}{3}\%$

(From Unit 4, Lesson 9.)

Problem 4

Statement

Noah is visiting his aunt in Texas. He wants to buy a belt buckle whose price is \$25. He knows that the sales tax in Texas is 6.25%.

- How much will the tax be on the belt buckle?
- How much will Noah spend for the belt buckle including the tax?
- Write an equation that represents the total cost, c , of an item whose price is p .

Solution

- \$1.56 (requires rounding)
- \$26.56
- $c = 1.0625p$ or equivalent

(From Unit 4, Lesson 10.)

Section: Let's Put It to Work

Lesson 17: Building Prisms

Goals

- Compare and contrast (orally) triangular prisms, including comparisons of their height, cross sections, surface area, and volume.
- Compose two triangular prisms into a new prism, and describe (orally and in writing) the composite shape.
- Draw and assemble a net of a triangular prism, given two side lengths of the prism's base and one angle measure.

Learning Targets

- I can build a triangular prism from scratch.

Lesson Narrative

This lesson is optional. In this culminating lesson, students use what they have learned in this unit to build a triangular prism, given some measures for the angles and sides of the triangular base. There are 4 possible solutions.

This lesson is organized into three activities. First, students draw triangles that could be the base of the prism, given the conditions. They select one of the 4 possible solutions and calculate its area. Then, students create and assemble a net for the prism. They calculate its volume and surface area. In the last activity, students experiment with different ways two prisms could be put together to make one larger prism. They analyze how different configurations affect the volume and surface area of the composed prism.

Alignments

Building On

- 6.G.A.4: Represent three-dimensional figures using nets made up of rectangles and triangles, and use the nets to find the surface area of these figures. Apply these techniques in the context of solving real-world and mathematical problems.

Addressing

- 7.G.A.2: Draw (freehand, with ruler and protractor, and with technology) geometric shapes with given conditions. Focus on constructing triangles from three measures of angles or sides, noticing when the conditions determine a unique triangle, more than one triangle, or no triangle.
- 7.G.B.6: Solve real-world and mathematical problems involving area, volume and surface area of two- and three-dimensional objects composed of triangles, quadrilaterals, polygons, cubes, and right prisms.

Instructional Routines

- MLR1: Stronger and Clearer Each Time
- MLR7: Compare and Connect
- MLR8: Discussion Supports

Required Materials

Compasses

Copies of Instructional master

Geometry toolkits

For grade 6: tracing paper, graph paper, colored pencils, scissors, and an index card to use as a straightedge or to mark right angles.

For grades 7 and 8: everything in grade 6, plus a ruler and protractor. Clear protractors with no holes and with radial lines printed on them are recommended.

Notes: (1) "Tracing paper" is easiest to use when it's a smaller size. Commercially-available "patty paper" is 5 inches by 5 inches and ideal for this. If using larger sheets of tracing paper, consider cutting them down for student use. (2) When compasses are required in grades 6-8 they are listed as a separate Required Material.

Rulers marked with centimeters

Required Preparation

Print a copy of the Instructional master for each student. Rulers should be part of the geometry toolkit, but make sure that rulers provided have markings in centimeters.

Student Learning Goals

Let's build a triangular prism from scratch.

17.1 Nets

Warm Up: 5 minutes

The purpose of this warm-up is for students to reason about prisms formed from various nets. During the partner and whole-group discussions, listen for how students name each prism: pentagonal prism, triangular prism, square prism (but not a cube), and select students who correctly name each prism to share during the whole-group discussion.

Building On

- 6.G.A.4

Launch

Arrange students in groups of 2. Give students 30 seconds of quiet think time to look at the nets followed by 2 minutes to describe each net with a partner.

Student Task Statement

Here are some nets for various prisms.

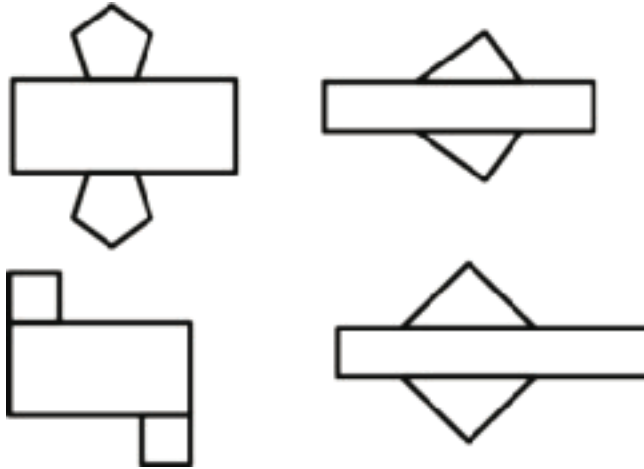

1. What would each net look like when folded?
2. What do you notice about the nets?

Student Response

1. From top left: A pentagonal prism, a triangular prism where the base is a right triangle, a square prism (but not a cube), a triangular prism where the base is an isosceles triangle.
2. Answers vary. Sample responses:
 - They all have a long rectangle in the middle.
 - The bases on the bottom are upside down compared to the bases on the top.
 - There's one base on each side of the rectangle.

Activity Synthesis

Ask selected students to describe the object formed by each net. Record and display their responses for all to see. If a student's description does not include the name of the prism, ask other students to name the object and explain how they know.

Ask students to share what they notice about all of the nets. Record and display their responses for all to see. While students may notice many things, important ideas to highlight during the discussion are:

- They all have a long rectangle in the middle.
- The bases on top and bottom are upside down.
- There's one base on each side of the rectangle.

17.2 Making the Base

Optional: 10 minutes

This activity reviews the work students did previously drawing shapes with given conditions. Students draw as many different triangles as they can that could be the base of the triangular prism, given two side lengths and one angle measure for the triangle.

In preparation for calculating surface area and volume in the next activity, students select one of their triangles and find its area. This will require them to draw and measure the height of the triangle. As needed, remind students that the height must be perpendicular to whichever side they are using as the base of their triangle. Also, prompt students to measure the height as precisely as possible, because it will influence the accuracy of their later calculations.

Addressing

- 7.G.A.2

Instructional Routines

- MLR7: Compare and Connect

Launch

Provide access to geometry toolkits and compasses.

Anticipated Misconceptions

Students may try to multiply two side lengths of the triangle to calculate the area. Remind them that the height must be perpendicular to the base. If necessary, demonstrate using an index card to draw in the height of the triangle.

Student Task Statement

The base of a triangular prism has one side that is 7 cm long, one side that is 5.5 cm long, and one angle that measures 45° .

1. Draw as many different triangles as you can with these given measurements.
2. Select one of the triangles you have drawn. Measure and calculate to approximate its area. Explain or show your reasoning.

Student Response

1. There are four possible triangles.

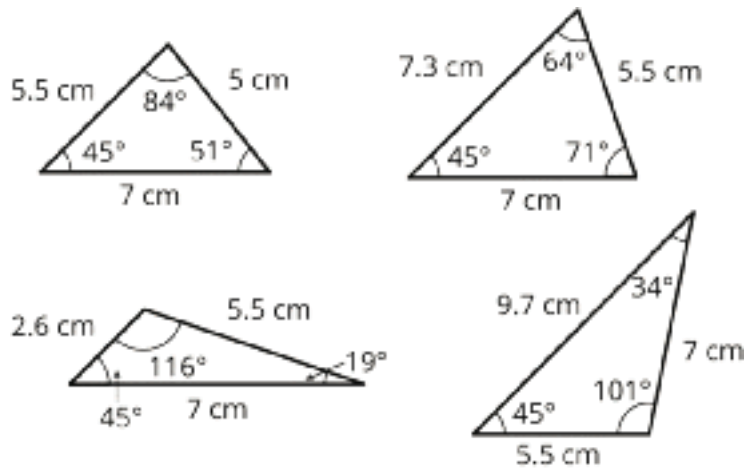

2. Answers vary depending on the selected triangle:

- The area is approximately 13.6 cm^2 for the triangle with the third side of 5.0 cm.
- The area is approximately 18.2 cm^2 for the triangle with the third side of 7.3 cm.
- The area is approximately 6.3 cm^2 for the triangle with the third side of 2.6 cm.
- The area is approximately 18.9 cm^2 for the triangle with the third side of 9.7 cm.

Activity Synthesis

Ask students to share triangles they drew so that everyone has an opportunity to see all four triangles. If any of the four triangles are not presented by students, demonstrate how to construct it. Ensure the class agrees that 4 unique triangles have the given measurements. The third side length of the triangle could be 5.0 cm, 7.3 cm, 2.6 cm, or 9.7 cm.

Make sure students have calculated the area of their selected triangle correctly, because this will affect their volume and surface area calculations in the next activity.

| If the third side of the triangle is | then the area of the triangle should be about | possible strategies |
|--------------------------------------|---|---|
| 5.0 cm | 13.7 cm ² | $\frac{1}{2} \cdot 7 \cdot (3.9)$ or $\frac{1}{2} \cdot (5.5) \cdot (5.0)$ |
| 7.3 cm | 18.2 cm ² | $\frac{1}{2} \cdot 7 \cdot (5.2)$ or $\frac{1}{2} \cdot (5.5) \cdot (6.6)$ or $\frac{1}{2} \cdot (7.3) \cdot (5.0)$ |
| 2.6 cm | 6.3 cm ² | $\frac{1}{2} \cdot 7 \cdot (1.8)$ or $\frac{1}{2} \cdot (5.5) \cdot (2.3)$ or $\frac{1}{2} \cdot (2.6) \cdot (5.0)$ |
| 9.7 | 18.9 cm ² | $\frac{1}{2} \cdot 7 \cdot (5.4)$ or $\frac{1}{2} \cdot (5.5) \cdot (6.9)$ or $\frac{1}{2} \cdot (9.7) \cdot (3.9)$ |

Access for English Language Learners

Representing, Conversing: MLR7 Compare and Connect. Invite students to prepare a visual display that shows how they measured and calculated the approximate area for their chosen triangle. Students should consider how to display their calculations so that another student can interpret them. For example, some students may wish to add notes or details to their drawings to help communicate their thinking. Arrange students in groups of 2–4. Give 2–3 minutes of quiet think time for students to read and interpret each other's calculations before they begin to discuss them. Display a list of questions that students can ask each other about their work. For example, "Can you show me how you measured the side lengths?", "How did you calculate the area of the triangle?", etc. During the whole-class discussion, draw students' attention to the relationship between measuring and approximating area. Emphasize the language used to make sense of the strategies used to measure and approximate area. These exchanges strengthen students' mathematical language use and reasoning based on the relationship between measures and area.

Design Principle(s): Maximize meta-awareness

17.3 Making the Prism

Optional: 10 minutes

In this activity, students take the triangle they selected in the previous activity and use it as the base of their triangular prism. After students have drawn their net and before they cut it out and assemble it, make sure they have correctly positioned their bases, opposite from each other on the top and bottom of the rectangle and reflected. It will also make assembling the net easier for students if they draw lines subdividing the large rectangle into the individual rectangular faces and draw tabs where the faces will be glued or taped together.

Addressing

- 7.G.B.6

Instructional Routines

- MLR1: Stronger and Clearer Each Time

Launch

Demonstrate the positions triangles should attach to the rectangle to form a net by displaying an example and describing the important parts:

- The triangles must have a vertex at A and C .
- The triangles must be identical copies with one “upside down” from the other.
- Corresponding sides of each triangle must be along the side of the rectangle.

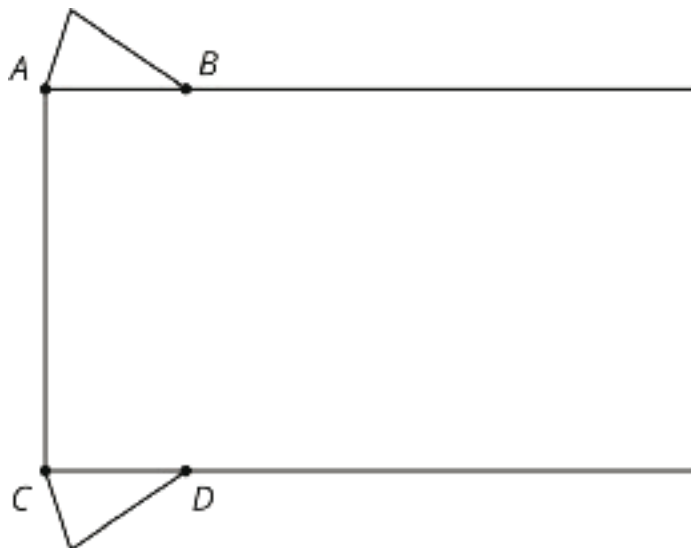

Access for Students with Disabilities

Engagement: Internalize Self Regulation. Check for understanding by inviting students to rephrase directions in their own words. Provide a project checklist that chunks the various steps of the activity into a set of manageable tasks.

Supports accessibility for: Organization; Attention

Student Task Statement

Your teacher will give you an incomplete net. Follow these instructions to complete the net and assemble the triangular prism:

1. Draw an identical copy of the triangle you selected in the previous activity along the top of the rectangle, with one vertex on point A .
2. Draw another copy of your triangle, flipped upside down, along the bottom of the rectangle, with one vertex on point C .
3. Determine how long the rectangle needs to be to wrap all the way around your triangular bases. Pause here so your teacher can review your work.
4. Cut out and assemble your net.

After you finish assembling your triangular prism, answer these questions. Explain or show your reasoning.

1. What is the volume of your prism?
2. What is the surface area of your prism?
3. Stand your prism up so it is sitting on its triangular base.
 - a. If you were to cut your prism in half horizontally, what shape would the cross section be?
 - b. If you were to cut your prism in half vertically, what shape would the cross section be?

Student Response

| If the third side of the triangle is | then the volume of the solid should be about | and the surface area of the solid should be about |
|--------------------------------------|--|---|
| 5.0 cm | 137 cm^3 | 202.2 cm^2 |
| 7.3 cm | 182 cm^3 | 234.4 cm^2 |
| 2.6 cm | 63 cm^3 | 163.6 cm^2 |
| 9.7 cm | 189 cm^3 | 259.8 cm^2 |

Cross sections:

- A triangle that is identical to the one I drew as my base.
- A rectangle with one side the same length as the height of the prism.

Activity Synthesis

Select students to share their answers for the cross sections. For cross sections taken in these two ways, all triangular prisms should have the same shapes as answers although the actual size of the cross section will differ based on the size of the base triangle and the height of the prism.

The volume and surface areas will depend on the triangle they have chosen to use as their base.

Select students to share their methods for computing volume and surface area. The base area is important in the calculation of each, so students should use the values they computed in the previous activity.

Access for English Language Learners

Writing, Speaking, Listening: MLR1 Stronger and Clearer Each Time. Use this routine to provide students a structured opportunity to refine their methods for calculating the volume of their prisms. Give students time to meet with 2–3 partners, to share and get feedback on their responses. Provide students with prompts for feedback that will help them strengthen their ideas and clarify their language. For example, “What did you do first?”, “What was your base?”, “Can you draw a picture?” Give students 1–2 minutes to revise their writing based on the feedback they received.

Design Principle(s): Optimize output (for explanation)

17.4 Combining Prisms

Optional: 10 minutes

Students combine their solid with a partner’s and examine the new solid’s properties.

If there is time, this activity can be extended to review relationships between angles as well.

- Take two of the prisms and put them together so that their 45° angles are adjacent. Ask students what type of angle is created and what the relationship between the two angles creating that angle must be. (a right angle, complementary angles)
- Take three identical prisms and put them together so that a different angle from each prism is adjacent.



Ask students what type of angle is created. (a straight angle) Ask students to identify pairs of angles that are supplementary.

Addressing

- 7.G.B.6

Instructional Routines

- MLR8: Discussion Supports

Launch

Arrange students in groups of 2.

Access for Students with Disabilities

Engagement: Develop Effort and Persistence. Provide prompts, reminders, rubrics, or checklists that focus on increasing the length of on-task orientation in the face of distractions. For example, provide students with the printed Student Task Statement to use as a checklist for task completion.

Supports accessibility for: Attention; Social-emotional skills

Anticipated Misconceptions

Student might struggle trying to measure and calculate the area of the base of their new prism if it is an irregular quadrilateral. Prompt them that they can just add the areas of the bases of their individual prisms together.

Student Task Statement

1. Compare your prism with your partner's prism. What is the same? What is different?
2. Find a way you can put your prism and your partner's prism together to make one new, larger prism. Describe your new prism.
3. Draw the base of your new prism and label the lengths of the sides.
4. As you answer these questions about your new prism, look for ways you can use your calculations from the previous activity to help you. Explain or show your reasoning.
 - a. What is the area of its base?
 - b. What is its height?
 - c. What is its volume?
 - d. What is its surface area?

Student Response

1. Both prisms have the same height. At least two side lengths of the base are the same. It is possible that both prisms are identical.

2. Answers vary based on which triangles and faces are used. Sample responses: A taller triangular prism, a prism with a parallelogram base, a wider triangular prism.
3. Answers for the base vary based on which triangles and faces are used. Sample responses: A triangle, a parallelogram.
4.
 - a. If the students glue two sides together, the area of the base should be the sum of the two individual triangle base areas. If the students glue identical bases together, the area of the base is the same as the original area of one of the bases.
 - b. Possible answers: 10 cm, 20 cm. The height of the prism will depend on the faces used to glue the parts together.
 - c. The volume of the combined object is the sum of the volume of the two individual triangular prisms.
 - d. The surface area of the combined object is the sum of the two individual objects minus twice the area of the shared face.

Are You Ready for More?

How many identical copies of your prism would it take you to put together a new larger prism in which every dimension was twice as long?

Student Response

You would need 8 identical prisms (or 7 copies in addition to your original).

Activity Synthesis

Discuss which attributes of the larger prisms were easiest to determine based on the original prisms and which were hardest.

Using two prisms that are identical, demonstrate putting them together against a matching side various ways.



In the first configuration,

- The area of the base is the same as in the original prism.
- The height is twice the height of the original prism.
- The volume is twice the volume of the original prism.
- The surface area is less than twice the surface area of the original prism (because of the sides that are put together).

In the second and third configurations,

- The area of the base is twice the original.
- The height is the same as the original.
- The volume is twice the original.
- The surface area is less than twice the original.

How could you put these two prisms together to make the largest surface area possible for the new prism? The smallest surface area possible?

Access for English Language Learners

Speaking: MLR8 Discussion Supports. When students share which attributes were easier or more challenging to determine, revoice student ideas to demonstrate mathematical language use. Encourage students to consider what details are important to share, and to think about how they will explain their reasoning using mathematical language. Invite other students to challenge an idea, elaborate on an idea, or give an additional example. This will help students to produce and make sense of the language needed to communicate their own ideas.

Design Principle(s): Support sense-making; Optimize output (for explanation)

Lesson Synthesis

Ask students to reflect on what they have learned in this unit, either in writing or by talking to a partner. Here are some suggested prompts:

- “What is something you learned in this unit that surprised you?”
- “What is a new mathematical word you learned in this unit, and what does it mean?”
- “What is an idea that you learned about in this unit that is useful in the real world?”
- “Describe something that you were confused about at first, but understand now.”
- “Describe something that you found challenging, but understood with some effort.”
- “What is something from this unit that you are still wondering about?”

- “What was your favorite activity, and what did you learn from it?”

CKMath™
Core Knowledge **MATHEMATICS™**



Family Support
Materials

Family Support Materials

Angles, Triangles, and Prisms

Here are the video lesson summaries for Grade 7, Unit 7: Angles, Triangles, and Prisms. Each video highlights key concepts and vocabulary that students learn across one or more lessons in the unit. The content of these video lesson summaries is based on the written Lesson Summaries found at the end of lessons in the curriculum. The goal of these videos is to support students in reviewing and checking their understanding of important concepts and vocabulary. Here are some possible ways families can use these videos:

- Keep informed on concepts and vocabulary students are learning about in class.
- Watch with their student and pause at key points to predict what comes next or think up other examples of vocabulary terms (the bolded words).
- Consider following the Connecting to Other Units links to review the math concepts that led up to this unit or to preview where the concepts in this unit lead to in future units.

| Grade 7, Unit 7: Angles, Triangles, and Prisms | Vimeo | YouTube |
|--|----------------------|----------------------|
| Video 1: Angle Relationships (Lessons 1–5) | Link | Link |
| Video 2: Drawing Polygons with Given Conditions (Lessons 6–10) | Link | Link |
| Video 3: Volume of Right Prisms and Pyramids (Lessons 11–13) | Link | Link |
| Video 4: Volume and Surface Area of Right Prisms (Lessons 14–16) | Link | Link |

Video 1

Video 'VLS G7U7V1 Angle Relationships (Lessons 1–5)' available here:
<https://player.vimeo.com/video/516923320>.

Video 2

Video 'VLS G7U7V2 Drawing Polygons with Given Conditions (Lessons 6–10)' available here:
<https://player.vimeo.com/video/516924015>.

Video 3

Video 'VLS G7U7V3 Volume of Right Prisms and Pyramids (Lessons 11–13)' available here:
<https://player.vimeo.com/video/519998551>.

Video 4

Video 'VLS G7U7V4 Volume and Surface Area of Right Prisms (Lessons 14–16)' available here: <https://player.vimeo.com/video/520348663>.

Connecting to Other Units

- *Coming soon*

Angle Relationships

Family Support Materials 1

This week your student will be working with some relationships between pairs of angles.

- If two angles add to 90° , then we say they are **complementary angles**. If two angles add to 180° , then we say they are **supplementary angles**. For example, angles JGF and JGH below are supplementary angles, because $30 + 150 = 180$.

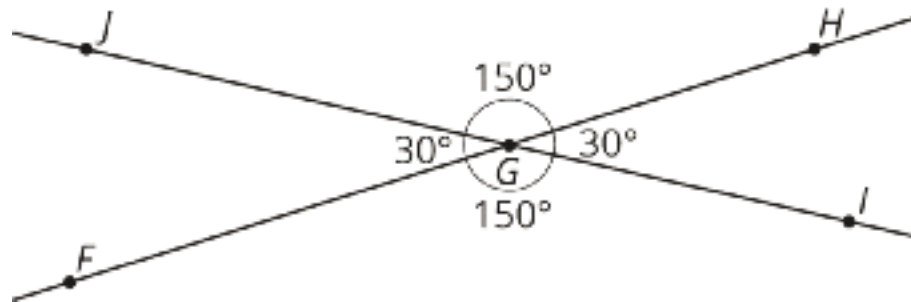

- When two lines cross, they form two pairs of **vertical angles** across from one another. In the previous figure, angles JGF and HGI are vertical angles. So are angles JGH and FGJ . Vertical angles always have equal measures.

Here is a task to try with your student: Rectangle $PQRS$ has points T and V on two of its sides.

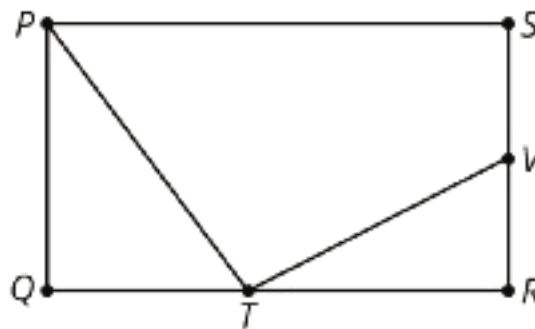

1. Angles SVT and TVR are supplementary. If angle SVT measures 117° , what is the measure of angle TVR ?
2. Angles QTP and QPT are complementary. If angle QTP measures 53° , what is the measure of angle QPT ?

Solution:

1. Angle TVR measures 63° , because $180 - 117 = 63$.

2. Angle QPT measures 37° , because $90 - 53 = 37$.

Drawing Polygons with Given Conditions

Family Support Materials 2

This week your student will be drawing shapes based on a description. What options do we have if we need to draw a triangle, but we only know some of its side lengths and angle measures?

- Sometimes we can draw more than one kind of triangle with the given information. For example, “sides measuring 5 units and 6 units, and an angle measuring 32° ” could describe two triangles that are not identical copies of each other.

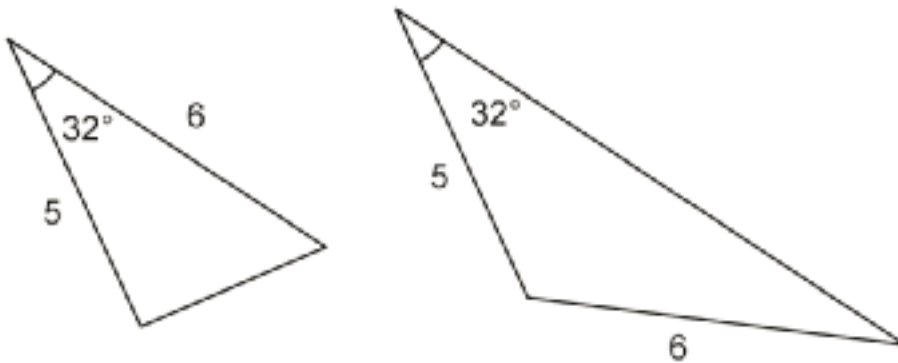

- Sometimes there is only one unique triangle based on the description. For example, here are two identical copies of a triangle with two sides of length 3 units and an angle measuring 60° . There is no way to draw a *different* triangle (a triangle that is not an identical copy) with this description.

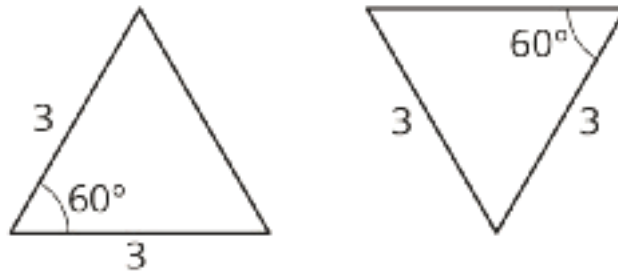

- Sometimes it is not possible to draw a triangle with the given information. For example, there is no triangle with sides measuring 4 inches, 5 inches, and 12 inches. (Try to draw it and see for yourself!)

Here is a task to try with your student:

Using each set of conditions, can you draw a triangle that is *not an identical copy* of the one shown?

1. A triangle with sides that measure 4, 6, and 9 units.

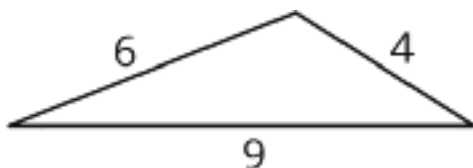

2. A triangle with a side that measures 6 units and angles that measure 45° and 90°

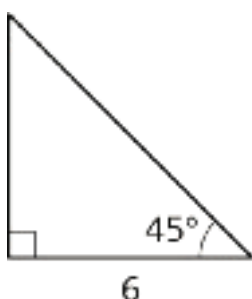

Solution:

1. There is no way to draw a *different* triangle with these side lengths. Every possibility is an identical copy of the given triangle. (You could cut out one of the triangles and match it up exactly to the other.) Here are some examples:

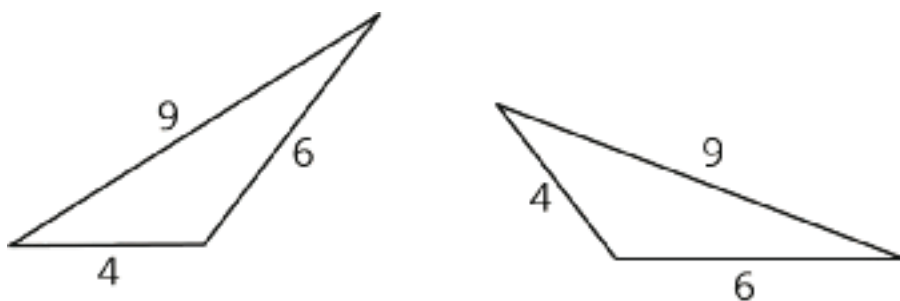

2. You can draw a different triangle by putting the side that is 6 opposite from the 90° angle instead of next to it. This is not an identical copy of the given triangle, because it is smaller.

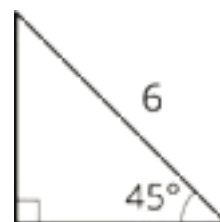

Solid Geometry

Family Support Materials 3

This week your student will be thinking about the surface area and volume of three-dimensional figures. Here is a triangular prism. Its base is a right triangle with sides that measure 12, 12, and 17 inches.

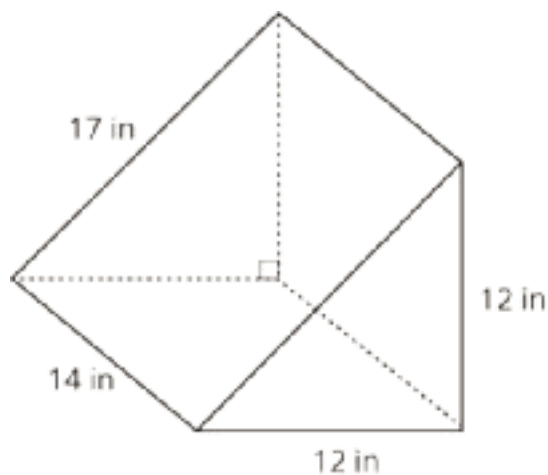

In general, we can find the volume of any prism by multiplying the area of its base times its height. For this prism, the area of the triangular base is 72 in^2 , so the volume is $72 \cdot 14$, or $1,008 \text{ in}^3$.

To find the surface area of a prism, we can find the area of each of the faces and add them up. The example prism has two faces that are triangles and three faces that are rectangles. When we add all these areas together, we see that the prism has a total surface area of $72 + 72 + 168 + 168 + 238$, or 718 in^2 .

Here is a task to try with your student:

The base of this prism is a hexagon where all the sides measure 5 cm. The area of the base is about 65 cm^2 .

1. What is the volume of the prism?

2. What is the surface area of the prism?

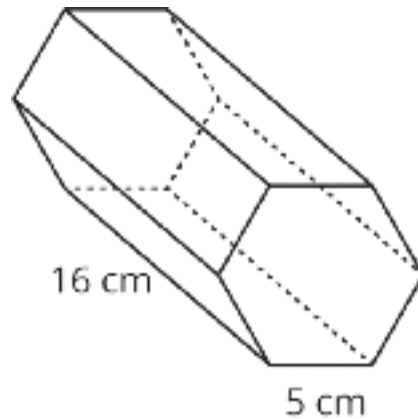

Solution:

1. The volume of the prism is about $1,040 \text{ cm}^3$, because $65 \cdot 16 = 1,040$.

2. The surface area of the prism is 610 cm^2 , because $16 \cdot 5 = 80$ and $65 + 65 + 80 + 80 + 80 + 80 + 80 + 80 = 610$.

Unit Assessments

Check Your Readiness A and B
End-of-Unit Assessment A and B

Angles, Triangles, and Prisms: Check Your Readiness (A)

You need a protractor and a separate straightedge.

1. How many degrees are there in a right angle?

- A. 60
- B. 90
- C. 180
- D. 360

2. Use a protractor to measure all four angles inside quadrilateral $ABCD$. Write the measure of each angle to the nearest whole degree.

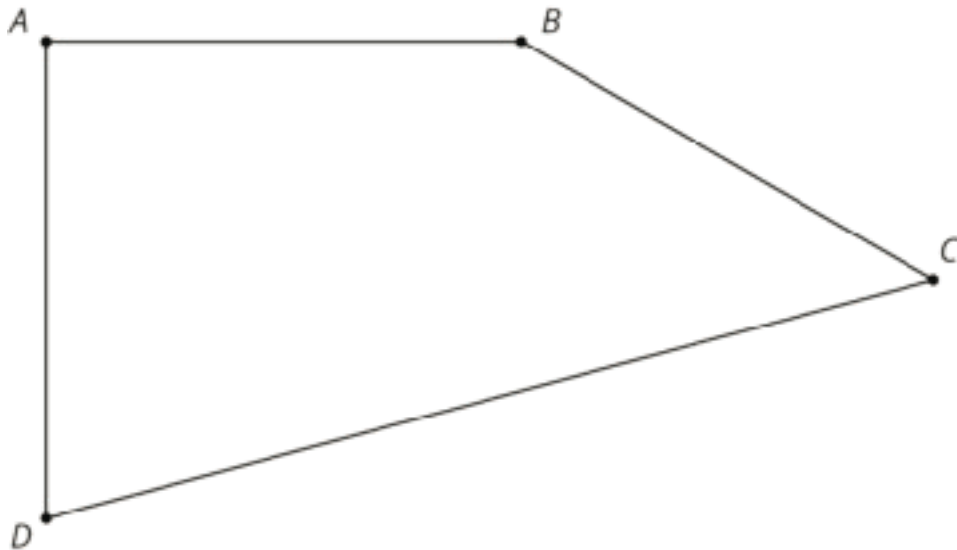

3. Use a protractor to draw an angle of each measure.

a. 30°

b. 140°

4. a. Draw a pair of parallel lines.

b. Draw a pair of perpendicular lines.

c. Draw an acute angle.

d. Draw an obtuse triangle.

5. Draw a right rectangular prism with a volume of 60 cm^3 . Label the edges you used to calculate the volume. Determine the area of the base. Include units in your results.

6. A right rectangular prism has a volume of 30 cubic inches. Its length is $\frac{1}{3}$ inch and its width is 3 feet. What is its height? Include units of measure in your response.

7. What is the area of this trapezoid?

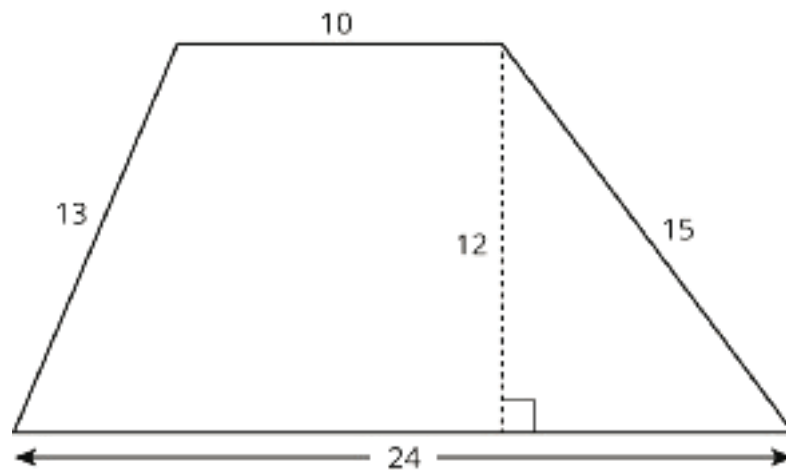

Angles, Triangles, and Prisms: Check Your Readiness (B)

You need a protractor and a separate straightedge.

1. What is a 90° angle called?
 - A. acute
 - B. obtuse
 - C. right
 - D. straight
2. Use a protractor to measure each of the 5 numbered angles. Write the measure of each angle to the nearest whole degree.

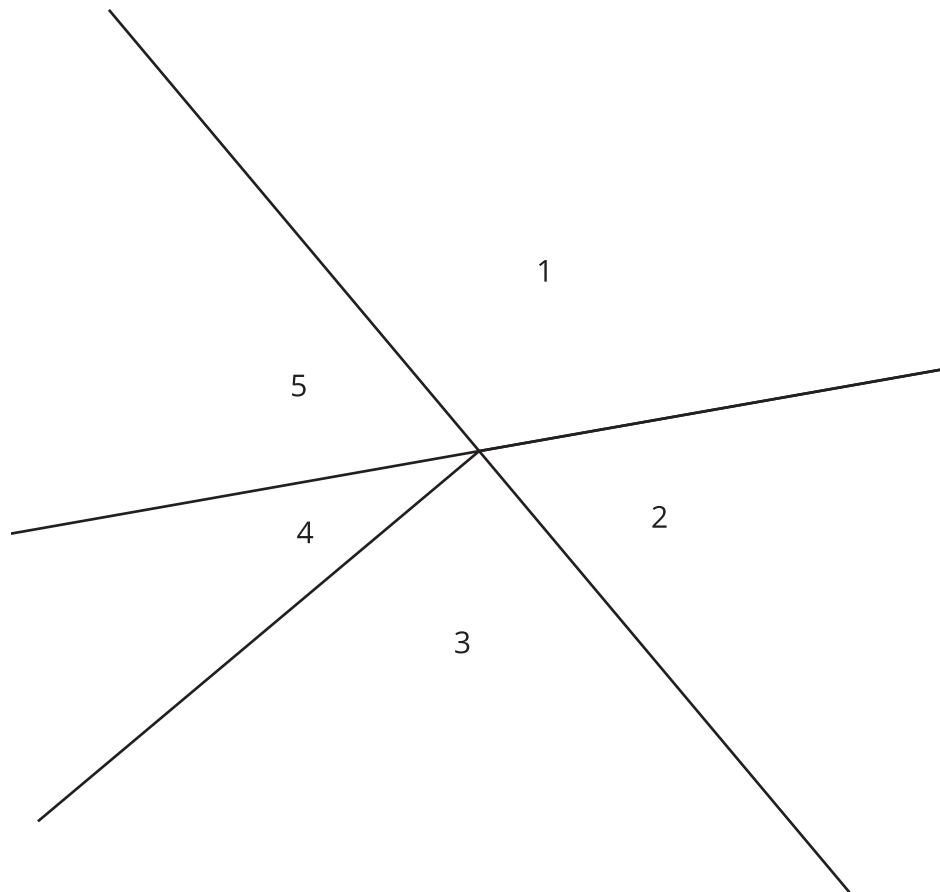

3. Use a protractor to draw an angle of each measure.

a. 120°

b. 50°

4. a. Draw a pair of perpendicular lines.

b. Draw a pair of parallel lines.

c. Draw a right triangle.

d. Draw an acute angle.

5. Draw a right rectangular prism with a volume of 90 cm^3 . Label the edges you used to calculate the volume. Determine the area of the base. Include units in your results.

6. A right rectangular prism has a length of 0.25 feet and a width of 5 inches .

a. Find a height so its volume is between 30 and 45 cubic inches.

b. What is the volume of your prism? Include units of measure in your response.

7. What is the area of this trapezoid?

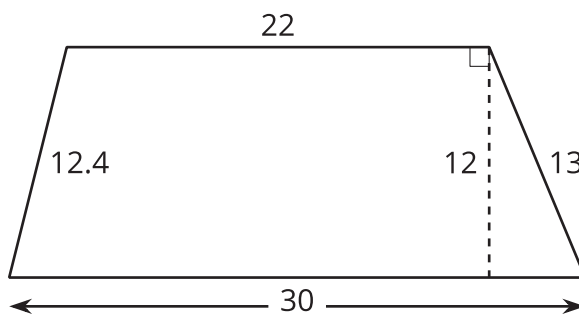

Angles, Triangles, and Prisms: End-of-Unit Assessment (A)

You may use a calculator. You will need a protractor to measure angles and a ruler to draw line segments.

1. Select **all** the conditions for which it is possible to construct a triangle.

- A. A triangle with angle measures 60° , 80° , and 80°
- B. A triangle with side lengths 4 cm, 5 cm, and 6 cm
- C. A triangle with side lengths 4 cm, 5 cm, and 15 cm
- D. A triangle with side lengths 4 cm and 5 cm and a 50° angle
- E. A triangle with angle measures 30° and 60° , and a 3 cm side length

2. A square pyramid is sliced parallel to the base and halfway up the pyramid.

Which of these describes the cross section?

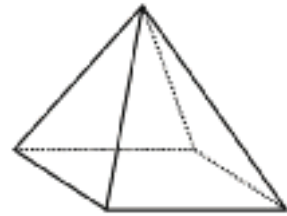

- A. A square smaller than the base
- B. A quadrilateral that is not a square
- C. A square the same size as the base
- D. A triangle with a height the same as the pyramid

3. Which of these describes a unique polygon?

- A. A triangle with angles 30° , 50° , and 100°
- B. A quadrilateral with each side length 5 cm
- C. A triangle with side lengths 6 cm, 7 cm, and 8 cm
- D. A triangle with side lengths 4 cm and 5 cm and a 50° angle

4. Here is a triangular prism.

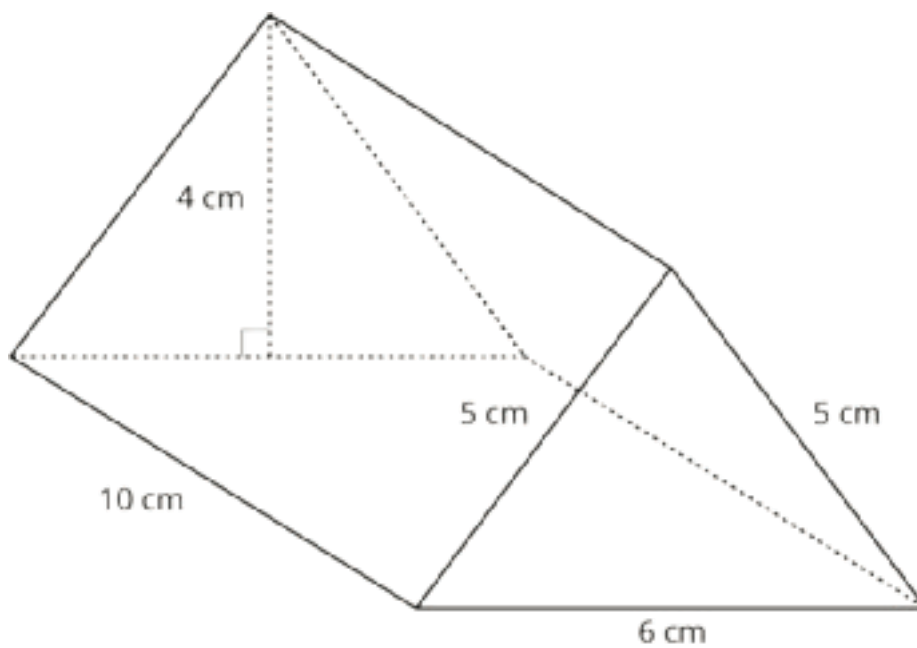

a. What is the volume of the prism, in cubic centimeters?

b. What is the surface area of the prism, in square centimeters?

5. Draw as many different triangles as possible that have two sides of length 4 cm and a 45° angle. Clearly mark the side lengths and angles given.

6. What are the values of x and y ?

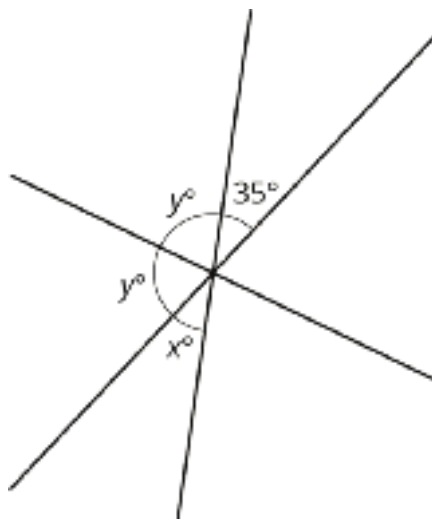

7. For each statement, provide an example showing that the statement can be true, or an explanation of why the statement can *never* be true.

a. Adjacent angles can be complementary.

b. Vertical angles can be supplementary.

c. Complementary angles can be supplementary.

Angles, Triangles, and Prisms: End-of-Unit Assessment (B)

You may use a calculator. You will need a protractor to measure angles and a ruler to draw line segments.

1. Select **all** the conditions for which it is possible to construct a triangle.
 - A. A triangle with angle measures 40° , 60° , and 80°
 - B. A triangle with side lengths 3 cm, 7 cm, and 11 cm
 - C. A triangle with side lengths 6 in, 13 in, and 12 in
 - D. A triangle with side lengths 8 cm and 5 cm and a 90° angle
 - E. A triangle with angle measures 120° and 70° , and a 9 cm side length

2. A rectangular pyramid is sliced. The slice passes through the vertex of the pyramid and is perpendicular to the base of the pyramid.

Which of these describes the cross section?

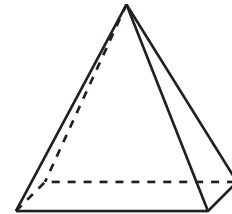

- A. A rectangle smaller than the base
- B. A quadrilateral that is not a rectangle
- C. A rectangle the same size as the base
- D. A triangle with a height the same as the pyramid

3. Which of these describes a unique polygon?

- A. A quadrilateral with 4 right angles
- B. A triangle with angles 30° , 80° , and 70°
- C. A triangle with side lengths 7 cm and 8 cm and a 70° angle
- D. A triangle with each side length 5 inches

4. Here is a triangular prism.

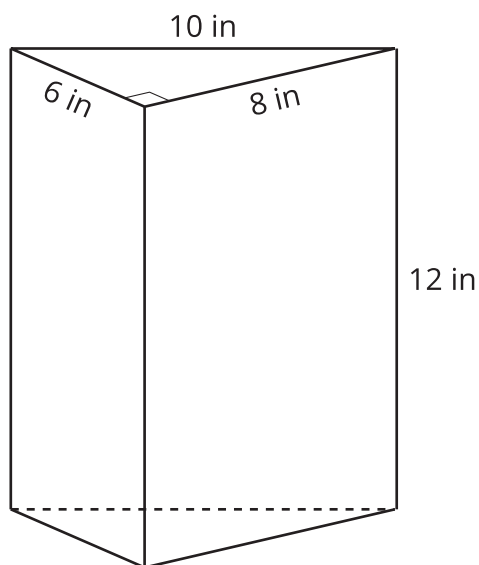

- a. What is the volume of the prism, in cubic inches?

- b. What is the surface area of the prism, in square inches?

5. Draw as many different triangles as possible that have a side of length 5 units, a 45° angle, and a 90° angle. Clearly mark the side lengths and angles given.

6. What are the values of x and y ?

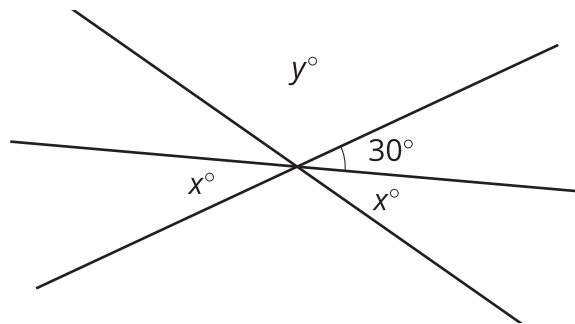

7. For each statement, provide an example showing that the statement can be true, or an explanation of why the statement can *never* be true.

a. Adjacent angles can be supplementary.

b. Vertical angles can be complementary.

c. Supplementary angles can be complementary.

CKMath™
Core Knowledge **MATHEMATICS™**

Assessment Answer Keys

Check Your Readiness A and B
End-of-Unit Assessment A and B

Assessment Answer Keys

Assessment : Check Your Readiness (A)

Teacher Instructions

Students need a protractor and a separate straightedge (a ruler is fine).

Student Instructions

You need a protractor and a separate straightedge.

Problem 1

The content assessed in this problem is first encountered in Lesson 1: Relationships of Angles.

Early in the unit, students are introduced to the vocabulary words “complementary” and “supplementary” as they pertain to angles. Later, students will write equations to solve for the measure of an unknown angle, where one of the givens is that two angles together form a right angle.

If most students struggle with this item, plan to reinforce the fact that we call an angle with a measure of 90 degrees a right angle.

Statement

How many degrees are there in a right angle?

- A. 60
- B. 90
- C. 180
- D. 360

Solution

B

Aligned Standards

4.G.A.1

Problem 2

The content assessed in this problem is first encountered in Lesson 2: Adjacent Angles.

Throughout the unit, students are expected to measure angles with a protractor in order to make conjectures such as “vertical angles are equal.”

If most students struggle with this item, plan to incorporate practice with a protractor before Lesson 2 Activity 2. An optional activity in Lesson 1 might also be a good place to revisit how a protractor is used to measure angles.

Statement

Use a protractor to measure all four angles inside quadrilateral $ABCD$. Write the measure of each angle to the nearest whole degree.

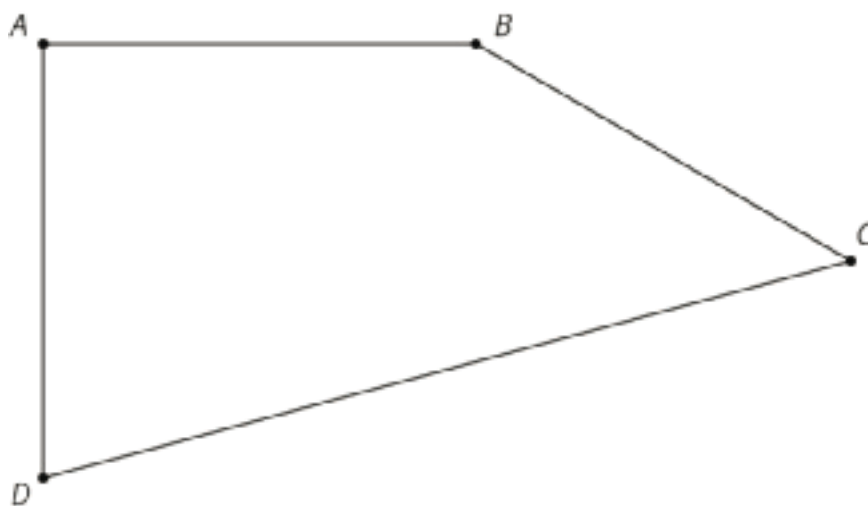

Solution

$A = 90$, $B = 150$, $C = 45$, $D = 75$. Measurements within ± 5 degrees should be accepted.

Aligned Standards

4.MD.C.6

Problem 3

The content assessed in this problem is first encountered in Lesson 9: Drawing Triangles (Part 1).

In this unit, students investigate the number of distinct polygons or triangles that can be drawn with given information: say, two sides and an angle. In some cases, students use protractors as a tool in constructing these shapes.

If most students struggle with this item, plan to incorporate drawing angles on tracing paper into earlier activities to verify measures of angles that are given. Students can place their tracing paper over the printed angles to check their drawings.

Statement

Use a protractor to draw an angle of each measure.

1. 30°
2. 140°

Solution

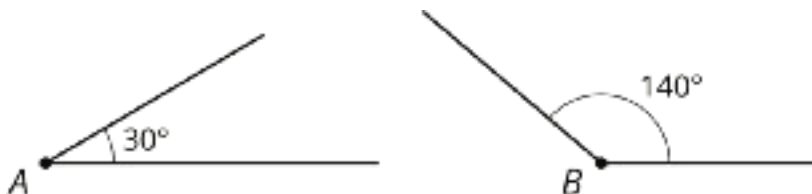

Aligned Standards

4.MD.C.6

Problem 4

The content assessed in this problem is first encountered in Lesson 11: Slicing Solids.

The content assessed in this problem is first encountered in Lesson 1: Relationships of Angles.

The content assessed in this problem is first encountered in Lesson 2: Adjacent Angles.

The content assessed in this problem is first encountered in Lesson 9: Drawing Triangles (Part 1).

These vocabulary words are all background for the geometric work of this unit. Watch for students drawing an obtuse angle instead of an obtuse triangle.

If most students struggle with the term parallel, plan to discuss in Lesson 9 Activity 3 that one of the triangles is impossible to draw because two sides end up being parallel. In Lesson 11, students may not have experience with parallel planes. Plan to connect the idea of parallel lines with parallel planes.

If most students struggle with the term perpendicular, plan to define perpendicular in Lesson 2 Activity 2 where students are told that they do not need to make a cut "perpendicular to the side of the paper." Perpendicular lines come up again in Lesson 3 Activity 3, as students learn that intersecting lines need not be perpendicular.

If most students struggle with the terms acute and obtuse, plan to define right, acute, and obtuse in Lesson 1 Activity 1. Consider making an anchor chart with names and types of angles that will be used throughout this unit.

Statement

1. Draw a pair of parallel lines.
2. Draw a pair of perpendicular lines.

3. Draw an acute angle.
4. Draw an obtuse triangle.

Solution

Answers vary.

Aligned Standards

4.G.A.1

Problem 5

The content assessed in this problem is first encountered in Lesson 12: Volume of Right Prisms.

In this unit, students study volume and surface area. In grade 6, they learned to calculate the volume of a rectangular prism. They also learned to calculate the surface area of prisms and other solids by adding up the area of each face.

If most students struggle with this item, plan to revisit it with students prior to Lesson 12, helping them to recall what they know about finding the volume of right rectangular prisms. You may also choose to present right rectangular prisms with given side lengths to find the volume in addition to this item which has a volume given.

If most students do well with this item, Optional Activity 4 in Lesson 12 gives students an opportunity to explore the same idea but with prisms other than right rectangular prisms.

Statement

Draw a right rectangular prism with a volume of 60 cm^3 . Label the edges you used to calculate the volume. Determine the area of the base. Include units in your results.

Solution

Answers vary. Sample response: a base with length 3 cm and width 4 cm, and height 5 cm. The base area is 12 cm^2 .

Aligned Standards

6.G.A.2

Problem 6

The content assessed in this problem is first encountered in Lesson 12: Volume of Right Prisms.

The volume formula for the area of a rectangular prism will be familiar to students from grade 6. They will not have had as much experience solving for height given volume. However, this problem provides students with an opportunity to connect their sixth grade work with their more recent work solving equations. Watch for students making the error of ignoring the change in units (width 3 feet versus 3 inches).

If most students struggle with this item, plan to discuss in part 2 of Activity 1 what we can tell about unknown side lengths of a right rectangular prism if we know something about the volume. You may connect this to the equation solving work students did in a prior unit. If students struggle to convert between feet and inches, that is not an expectation of this unit and does not need to be addressed for success.

Statement

A right rectangular prism has a volume of 30 cubic inches. Its length is $\frac{1}{3}$ inch and its width is 3 feet. What is its height? Include units of measure in your response.

Solution

$2\frac{1}{2}$ inches (or equivalent)

Aligned Standards

4.MD.A.1, 6.G.A.2

Problem 7

The content assessed in this problem is first encountered in Lesson 13: Decomposing Bases for Area.

The content assessed in this problem is first encountered in Lesson 15: Distinguishing Volume and Surface Area.

In grade 6 students used strategies such as decomposing, rearranging, enclosing and subtracting to calculate the area of polygons. In this unit, students will apply these strategies to find the area of the base of a prism when studying volume and surface area.

If most students struggle with this item, review these strategies and plan to spend extra time discussing Lesson 13 Activity 2. Revisit this item and invite students to share how they could use these strategies to find the area of the trapezoid during the synthesis of Lesson 13 Activity 2.

Statement

What is the area of this trapezoid?

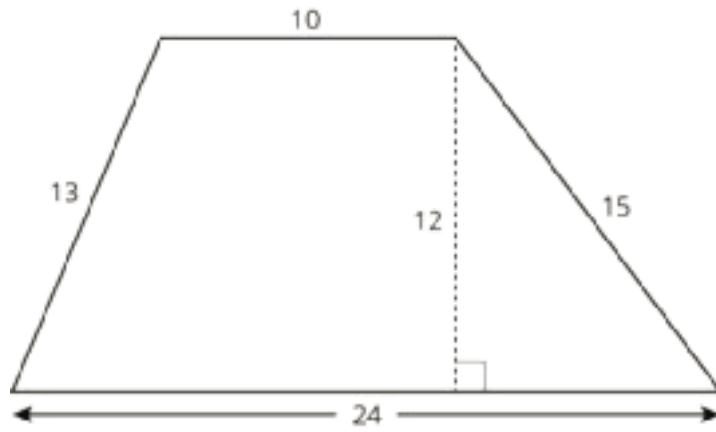

Solution

204 square units

Aligned Standards

6.G.A.1

Assessment : Check Your Readiness (B)

Teacher Instructions

Students need a protractor and a separate straightedge (a ruler is fine).

Student Instructions

You need a protractor and a separate straightedge.

Problem 1

The content assessed in this problem is first encountered in Lesson 1: Relationships of Angles.

Early in the unit, students are introduced to the terms “complementary” and “supplementary” as they pertain to angles. Later, students will write equations to solve for the measure of an unknown angle, in which one of the givens is that two angles together form a right angle.

If most students struggle with this item, plan to reinforce the fact that we call an angle with a measure of 90 degrees a right angle.

Statement

What is a 90° angle called?

- A. acute
- B. obtuse
- C. right
- D. straight

Solution

C

Aligned Standards

4.G.A.1

Problem 2

The content assessed in this problem is first encountered in Lesson 2: Adjacent Angles.

Throughout the unit, students are expected to measure angles with a protractor in order to make conjectures such as “vertical angles are equal.”

If most students struggle with this item, plan to incorporate practice with a protractor before Lesson 2 Activity 2. An optional activity in Lesson 1 might also be a good place to revisit how a protractor is used to measure angles.

Statement

Use a protractor to measure each of the 5 numbered angles. Write the measure of each angle to the nearest whole degree.

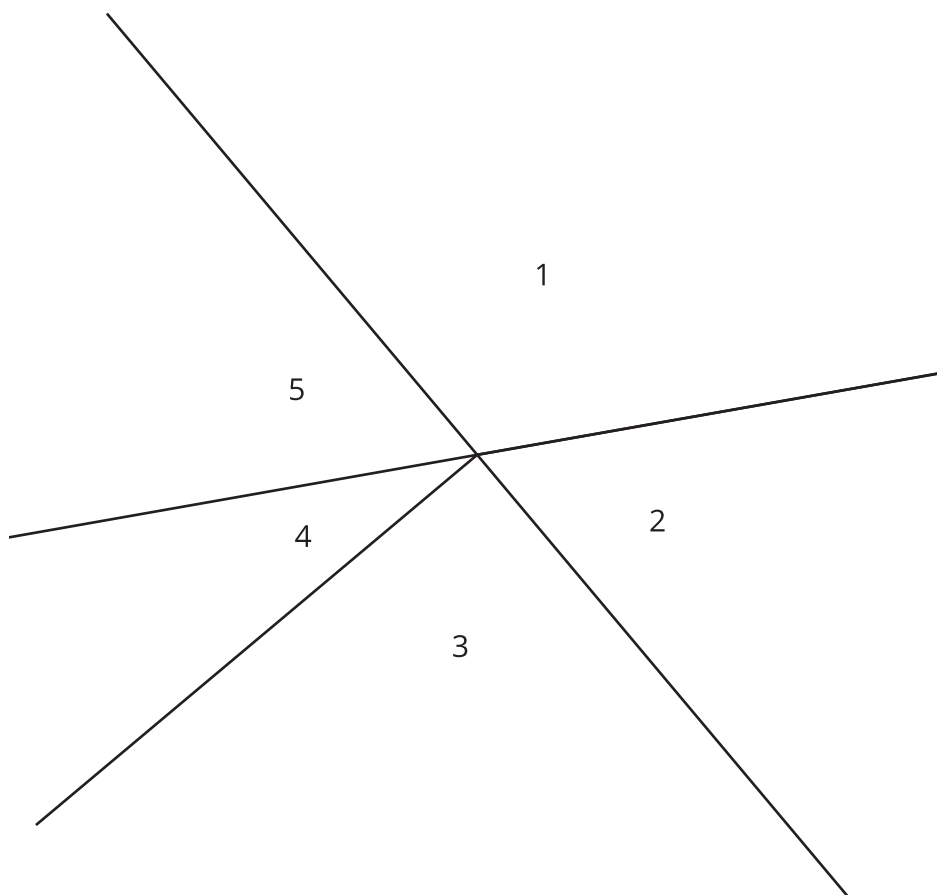

Solution

$1 = 120^\circ$, $2 = 60^\circ$, $3 = 90^\circ$, $4 = 30^\circ$, and $5 = 60^\circ$. Measurements within ± 5 degrees should be accepted.

Aligned Standards

4.MD.C.6

Problem 3

The content assessed in this problem is first encountered in Lesson 9: Drawing Triangles (Part 1).

In this unit, students investigate the number of distinct polygons or triangles that can be drawn with given information; for example, with two sides and an angle. In some cases, students use protractors as a tool in constructing these shapes.

If most students struggle with this item, plan to incorporate drawing angles on tracing paper into earlier activities to verify measures of angles that are given. Students can place their tracing paper over the printed angles to check their drawings.

Statement

Use a protractor to draw an angle of each measure.

1. 120°
2. 50°

Solution

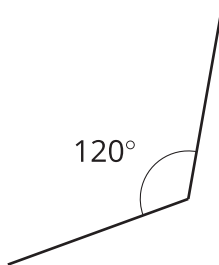

1.

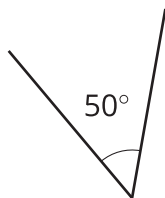

2.

Aligned Standards

4.MD.C.6

Problem 4

The content assessed in this problem is first encountered in Lesson 1: Relationships of Angles.

The content assessed in this problem is first encountered in Lesson 2: Adjacent Angles.

The content assessed in this problem is first encountered in Lesson 9: Drawing Triangles (Part 1).

The content assessed in this problem is first encountered in Lesson 11: Slicing Solids.

These vocabulary words are all background for the geometric work of this unit.

If most students struggle with the term parallel, plan to discuss in Lesson 9 Activity 3 that one of the triangles is impossible to draw because two sides end up being parallel. In Lesson 11, students may

not have experience with parallel planes. Plan to connect the idea of parallel lines with parallel planes.

If most students struggle with the term perpendicular, plan to define perpendicular in Lesson 2 Activity 2 where students are told that they do not need to make a cut "perpendicular to the side of the paper." Perpendicular lines come up again in Lesson 3 Activity 3, as students learn that intersecting lines need not be perpendicular.

If most students struggle with the terms right and acute, plan to define right, acute and obtuse angles in Lesson 1 Activity 1. Consider making an anchor chart with names and types of angles that will be used throughout this unit.

Statement

1. Draw a pair of perpendicular lines.
2. Draw a pair of parallel lines.
3. Draw a right triangle.
4. Draw an acute angle.

Solution

Answers vary.

Aligned Standards

4.G.A.1

Problem 5

The content assessed in this problem is first encountered in Lesson 12: Volume of Right Prisms.

In this unit, students study volume and surface area. In grade 6, they learned to calculate the volume of a rectangular prism. They also learned to calculate the surface area of prisms and other solids by adding up the area of each face.

If most students struggle with this item, plan to revisit it with students prior to Lesson 12, helping them to recall what they know about finding the volume of right rectangular prisms. You may also choose to present right rectangular prisms with given side lengths to find the volume in addition to this item which has a volume given.

If most students do well with this item, Optional Activity 4 in Lesson 12 gives students an opportunity to explore the same idea but with prisms other than right rectangular prisms.

Statement

Draw a right rectangular prism with a volume of 90 cm^3 . Label the edges you used to calculate the volume. Determine the area of the base. Include units in your results.

Solution

Answers vary. Sample response: a base with length 5 cm and width 2 cm, and height 9 cm. The base area is 10 cm^2 .

Aligned Standards

6.G.A.2

Problem 6

The content assessed in this problem is first encountered in Lesson 12: Volume of Right Prisms.

The volume formula for the area of a rectangular prism will be familiar to students from grade 6. They will not have had as much experience solving for height given volume. However, this problem provides students with an opportunity to connect their sixth grade work with their more recent work solving equations. Watch for students making the error of ignoring the change in units (feet vs. inches).

If most students struggle with this item, plan to discuss in part 2 of Activity 1 what we can tell about unknown side lengths of a right rectangular prism if we know something about the volume. You may connect this to the equation solving work students did in a prior unit. If students struggle to convert between feet and inches, that is not an expectation of this unit and does not need to be addressed for success.

Statement

A right rectangular prism has a length of 0.25 *feet* and a width of 5 *inches*.

1. Find a height so its volume is between 30 and 45 cubic inches.
2. What is the volume of your prism? Include units of measure in your response.

Solution

Answers vary. Sample response: a height of 2 inches will produce a volume of 30 cubic inches.

Aligned Standards

4.MD.A.1, 6.G.A.2

Problem 7

The content assessed in this problem is first encountered in Lesson 13: Decomposing Bases for Area.

In this unit, students will need to find the area of a trapezoidal base for a prism when studying volume and surface area.

If most students struggle with this item, review these strategies and plan to spend extra time discussing Lesson 13 Activity 2. Revisit this item and invite students to share how they could use these strategies to find the area of the trapezoid during the synthesis of Lesson 13 Activity 2.

Statement

What is the area of this trapezoid?

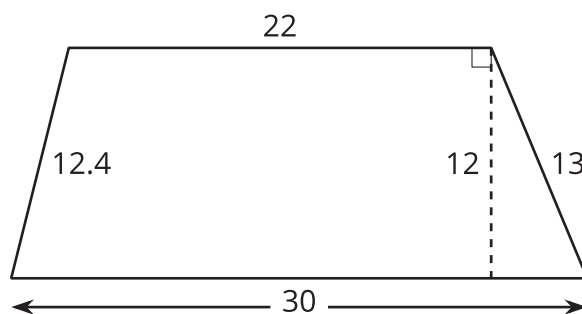

Solution

312 square units

Aligned Standards

6.G.A.1

Assessment : End-of-Unit Assessment (A)

Teacher Instructions

Calculators are optional but not required. Provide access to geometry toolkit.

Student Instructions

You may use a calculator. You will need a protractor to measure angles and a ruler to draw line segments.

Problem 1

Students selecting A may need more work on approximate angle measures; the angles are much too large. Students failing to select B, or students selecting C, need a review of the triangle inequality: 4 cm, 5 cm, and 6 cm are fine, and 15 cm is far too long. Students failing to select D or E may have said so because they aren't given the specific locations of the sides and angles, but this is a reason for more than one triangle to exist with the given conditions.

Statement

Select **all** the conditions for which it is possible to construct a triangle.

- A. A triangle with angle measures 60° , 80° , and 80°
- B. A triangle with side lengths 4 cm, 5 cm, and 6 cm
- C. A triangle with side lengths 4 cm, 5 cm, and 15 cm
- D. A triangle with side lengths 4 cm and 5 cm and a 50° angle
- E. A triangle with angle measures 30° and 60° , and a 3 cm side length

Solution

["B", "D", "E"]

Aligned Standards

7.G.A.2

Problem 2

Students selecting B may have drawn the shape but did not notice or understand that it is still a square. Students selecting C are likely to have pyramids and prisms confused, even though the pyramid is given. Students selecting D have probably drawn a vertical cross section.

Statement

A square pyramid is sliced parallel to the base and halfway up the pyramid.

Which of these describes the cross section?

- A. A square smaller than the base
- B. A quadrilateral that is not a square
- C. A square the same size as the base
- D. A triangle with a height the same as the pyramid

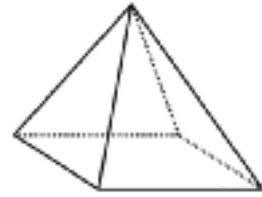

Solution

A

Aligned Standards

7.G.A.3

Problem 3

Students selecting A need some refresher work on the activities of this unit, since a scaled copy of the triangle will have the same angle measures. Students selecting B may have assumed the shape is a square from its description, but it could also be a rhombus of many different angles. Students selecting D did not recognize that the stated angle's location was not given, allowing there to be multiple triangles with this information.

Statement

Which of these describes a unique polygon?

- A. A triangle with angles 30° , 50° , and 100°
- B. A quadrilateral with each side length 5 cm
- C. A triangle with side lengths 6 cm, 7 cm, and 8 cm
- D. A triangle with side lengths 4 cm and 5 cm and a 50° angle

Solution

C

Aligned Standards

7.G.A.2

Problem 4

Students may have trouble determining the area of the base. The height found in the back triangle (4 cm) is needed. Students answering 150 for the volume and 190 for the surface area have likely made this error, using 5 cm for the altitude of the base.

Statement

Here is a triangular prism.

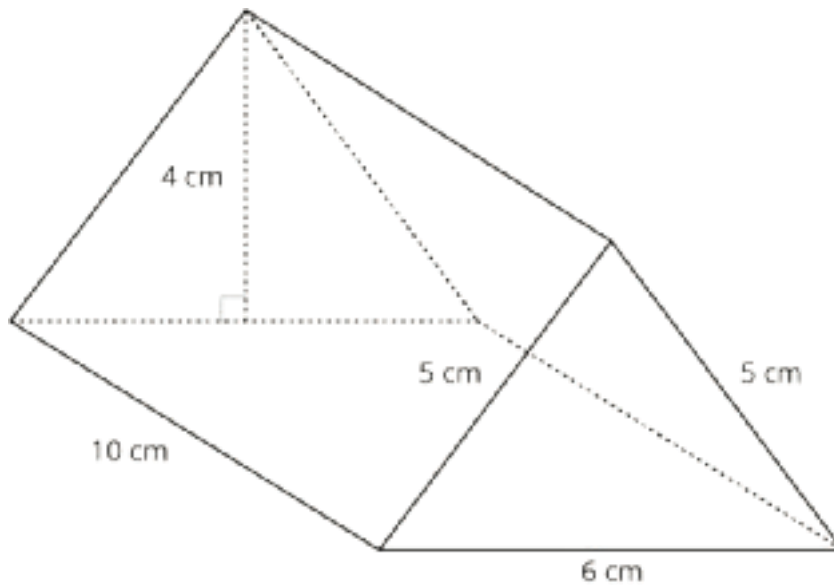

1. What is the volume of the prism, in cubic centimeters?
2. What is the surface area of the prism, in square centimeters?

Solution

1. 120 (the base area is 12 square cm, and the height is 10 cm)
2. 184 (the two bases have area 12, and the rectangular faces have area 60, 50, and 50)

Aligned Standards

7.G.B.6

Problem 5

Some students may accidentally draw a third triangle (with the 45° angle in a third position); they should attempt to verify that it is the same as one of the others (generally, it should be another of the triangles, flipped over). The given information forces 2 possible triangles and not 3 because the two given side lengths are equal.

Statement

Draw as many different triangles as possible that have two sides of length 4 cm and a 45° angle. Clearly mark the side lengths and angles given.

Solution

There are 2 different triangles.

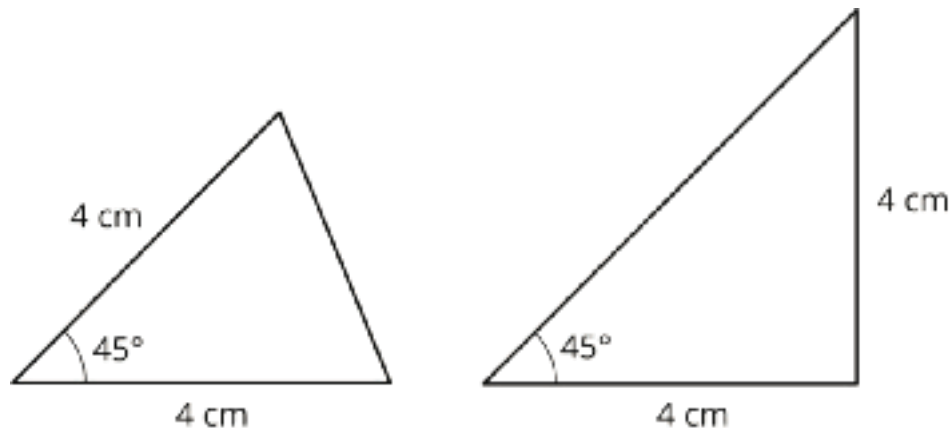

Minimal Tier 1 response:

- Work is complete and correct.
- Sample: exactly 2 triangles are drawn; lengths and angles marked and reasonably accurate; no other lengths or angles are marked.
- Acceptable errors: other lengths and angles, besides the ones given, may be marked with reasonable approximations of their measures; sum of marked measures of three angles close to, but not equal to, 180 degrees.

Tier 2 response:

- Work shows general conceptual understanding and mastery, with some errors.
- Sample errors: 3 triangles instead of 2; 45° angle drawn with significant inaccuracy; sides of length 4 cm drawn with significant inaccuracy, notably if they are significantly different in length; other lengths and angles, besides the ones given, measured or marked with significant inaccuracy.

Tier 3 response:

- Significant errors in work demonstrate lack of conceptual understanding or mastery.
- Sample errors: 0 triangles, 1 triangle, or more than 3 triangles drawn; two or more error types from Tier 2 response; an explanation of why the triangle cannot be drawn.

Aligned Standards

7.G.A.2

Problem 6

Give students credit for an answer for y that is based on an incorrect answer for x , since students may have used the relationship $x + 2y = 180$ to find y .

Students should not be penalized for including the degree symbol in their answers.

Statement

What are the values of x and y ?

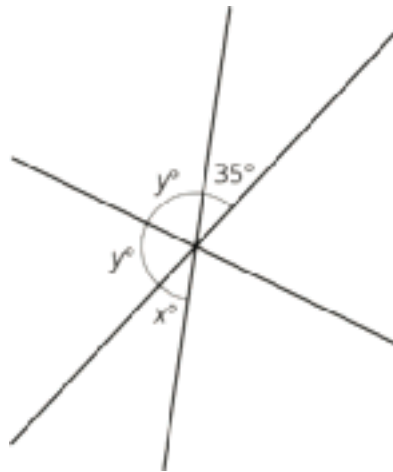

Solution

$x = 35$, $y = 72.5$ (The angle marked x and the angle marked as 35° are vertical angles, so they have the same measure. The two angles marked y , along with the angle marked as 35° , form a straight line. Therefore, $2y + 35 = 180$, and $y = 72.5$.)

Aligned Standards

7.EE.B.4, 7.G.B.5

Problem 7

Watch for students' clear understanding of the meanings of the key terms. It is still possible to incorrectly answer the questions when knowing the terms, but important to know the source of student errors.

Note that although the provided solution includes angle markings, they are not required. However, students need to indicate or describe which angles they are referring to in the diagram with vertical angles, otherwise it is unclear that they know which are vertical.

Statement

For each statement, provide an example showing that the statement can be true, or an explanation of why the statement can *never* be true.

1. Adjacent angles can be complementary.
2. Vertical angles can be supplementary.
3. Complementary angles can be supplementary.

Solution

Answers vary. Sample responses:

1. Angles measuring 60° and 30° meet at a vertex to form a right angle.

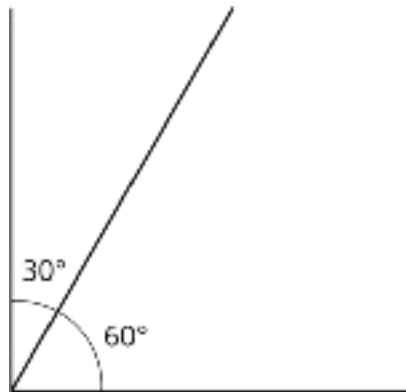

2. Two lines intersecting at a right angle form pairs of 90° vertical angles that are supplementary. The two marked angles below are vertical and supplementary.

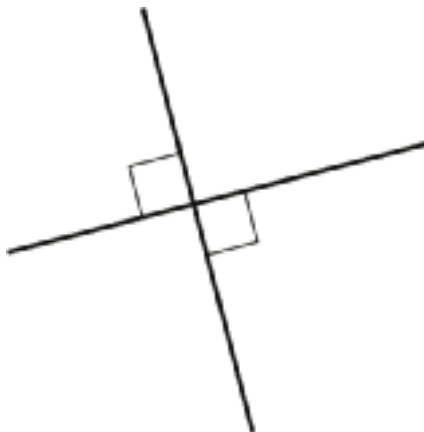

3. This is impossible. Complementary angles' measures add to 90° , while supplementary angles' measures add to 180° . This cannot happen at the same time.

Minimal Tier 1 response:

- Work is complete and correct, with complete explanation or justification.

- Sample:

1. Drawing of two angles meeting to form a right angle. No angle measures need to be marked.
2. Drawing of two perpendicular lines, with two angles clearly indicated. No angle measures or right angle marking is required.
3. No, because complementary angles add to 90° and supplementary angles add to 180° .

Tier 2 response:

- Work shows good conceptual understanding and mastery, with either minor errors or correct work with insufficient explanation or justification.
- Sample errors: an explanation that vertical angles cannot be supplementary that includes visible evidence of understanding the definition and meaning of both terms; an explanation that adjacent angles cannot be complementary that includes visible evidence of understanding the definition and meaning of both terms; an attempt to make two angles that are both complementary and supplementary that includes visible evidence of understanding the definition and meaning of both terms; two intersecting lines at a right angle without clearly marking which two angles are vertical and supplementary.

Tier 3 response:

- Work shows a developing but incomplete conceptual understanding, with significant errors.
- Sample errors: serious error(s) caused by a misunderstanding of one of the terms complementary, supplementary, vertical, adjacent; omission of one of the three parts.

Tier 4 response:

- Work includes major errors or omissions that demonstrate a lack of conceptual understanding and mastery.
- Sample errors: serious errors caused by misunderstanding of more than one of the terms; omission of two or more of the three parts.

Aligned Standards

7.G.B.5

Assessment : End-of-Unit Assessment (B)

Teacher Instructions

Calculators are optional but not required. Provide access to geometry toolkit.

Student Instructions

You may use a calculator. You will need a protractor to measure angles and a ruler to draw line segments.

Problem 1

Students failing to select A, or students selecting E, may need more work on approximate angle measures and calculating their sums. Students failing to select C, or students selecting B, need a review of the triangle inequality: 6, 12, and 13 is fine, but 11 cm is too long to be the third side of a triangle containing side lengths of 3 cm and 7 cm. Students failing to select D may have said so because they aren't given the specific locations of the sides and angles, but this is a reason for more than one triangle to exist with the given conditions.

Statement

Select **all** the conditions for which it is possible to construct a triangle.

- A. A triangle with angle measures 40° , 60° , and 80°
- B. A triangle with side lengths 3 cm, 7 cm, and 11 cm
- C. A triangle with side lengths 6 in, 13 in, and 12 in
- D. A triangle with side lengths 8 cm and 5 cm and a 90° angle
- E. A triangle with angle measures 120° and 70° , and a 9 cm side length

Solution

["A", "C", "D"]

Aligned Standards

7.G.A.2

Problem 2

Students selecting A, B, or C have probably drawn a different cross section that isn't going from the top of the pyramid down to the base.

Statement

A rectangular pyramid is sliced. The slice passes through the vertex of the pyramid and is perpendicular to the base of the pyramid.

Which of these describes the cross section?

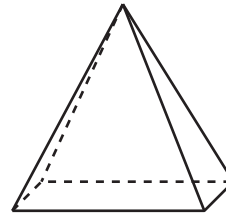

- A. A rectangle smaller than the base
- B. A quadrilateral that is not a rectangle
- C. A rectangle the same size as the base
- D. A triangle with a height the same as the pyramid

Solution

D

Aligned Standards

7.G.A.3

Problem 3

Students selecting A and B need some refresher work on the activities of this unit, since a scaled copy of any polygon will have the same angle measures. Students selecting C did not recognize that the stated angle's location was not given, allowing there to be multiple triangles with this information.

Statement

Which of these describes a unique polygon?

- A. A quadrilateral with 4 right angles
- B. A triangle with angles 30° , 80° , and 70°
- C. A triangle with side lengths 7 cm and 8 cm and a 70° angle
- D. A triangle with each side length 5 inches

Solution

D

Aligned Standards

7.G.A.2

Problem 4

Students may have trouble determining the area of the base. Students may have various answers that are different from the solution for surface area if they don't account for all the lateral faces of the prism.

Statement

Here is a triangular prism.

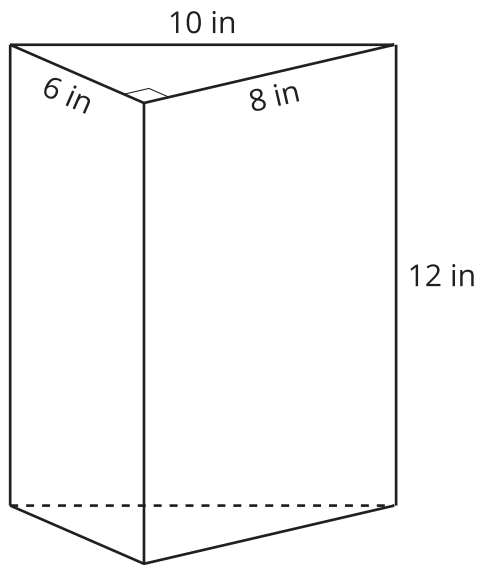

1. What is the volume of the prism, in cubic inches?
2. What is the surface area of the prism, in square inches?

Solution

1. 288 (the base area is 24 square inches, and the height is 12 inches)
2. 336 (the two bases have area 24 , and the rectangular faces have areas 72, 96, and 120)

Aligned Standards

7.G.B.6

Problem 5

The given information forces 2 possible triangles and not 3. Some students may accidentally draw a third triangle (with the 5m length in a third position); they should attempt to verify that it is the same as one of the others (generally, it should be the same as one of the other triangles, flipped over).

Statement

Draw as many different triangles as possible that have a side of length 5 units, a 45° angle, and a 90° angle. Clearly mark the side lengths and angles given.

Solution

There are 2 different triangles.

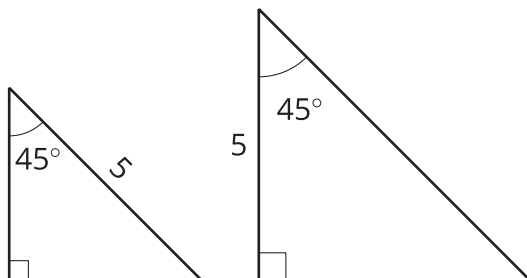

Minimal Tier 1 response:

- Work is complete and correct.
- Sample: exactly 2 triangles are drawn; lengths and angles marked and reasonably accurate; no other lengths or angles are marked.
- Acceptable errors: other lengths and angles, besides the ones given, may be marked with reasonable approximations of their measures; sum of marked measures of three angles close to, but not equal to, 180 degrees.

Tier 2 response:

- Work shows general conceptual understanding and mastery, with some errors.
- Sample errors: 3 triangles instead of 2; 45° degree angle drawn with significant inaccuracy; the third angle is drawn and labeled as something else other than a 45° degree angle; other lengths and angles, besides the ones given, measured or marked with significant inaccuracy.

Tier 3 response:

- Significant errors in work demonstrate lack of conceptual understanding or mastery.
- Sample errors: 0 triangles, 1 triangle, or more than 3 triangles drawn; two or more error types from Tier 2 response; an explanation of why the triangle cannot be drawn.

Aligned Standards

7.G.A.2

Problem 6

Give students credit for an answer for y that is based on an incorrect answer for x , since students may have used the relationship $x + y + 30 = 180$ to find y . Students should not be penalized for including the degree symbol in their answers.

Statement

What are the values of x and y ?

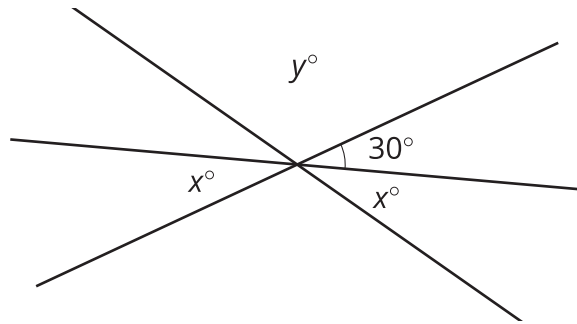

Solution

$x = 30$, $y = 120$ (The angle marked x and the angle marked as 30° are vertical angles, so they have the same measure. The angles marked x and y , along with the angle marked as 30° , form a straight line. Therefore, $x + y + 30 = 180$, and $y = 120$.)

Aligned Standards

7.EE.B.4, 7.G.B.5

Problem 7

Watch for students' clear understanding of the meanings of the key terms. It is still possible to incorrectly answer the questions when knowing the terms, but important to know the source of student errors. Note that although the provided solution includes angle markings, they are not required. However, students need to indicate or describe which angles they are referring to in the diagram with vertical angles, otherwise it is unclear that they know which are vertical.

Statement

For each statement, provide an example showing that the statement can be true, or an explanation of why the statement can *never* be true.

1. Adjacent angles can be supplementary.
2. Vertical angles can be complementary.
3. Supplementary angles can be complementary.

Solution

Answers vary. Sample responses:

1. Angles measuring 60° and 120° meet at a vertex to form a straight angle.

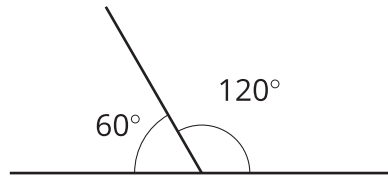

2. Two lines intersecting to form pairs of 45° vertical angles that are complementary. The two marked angles below are vertical and complementary.

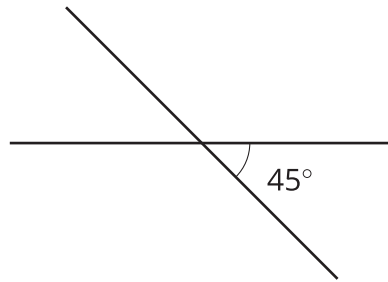

3. This is impossible. Supplementary angles' measures add to 180° , while complementary angles' measures add to 90° . This cannot happen at the same time.

Minimal Tier 1 response:

- Work is complete and correct, with complete explanation or justification.
- Sample:
 1. Drawing of two angles meeting to form a straight line. No angle measures need to be marked.
 2. Drawing of two intersecting lines, with at least one angle clearly indicated as 45° .
 3. No, because complementary angles add to 90° and supplementary angles add to 180° .

Tier 2 response:

- Work shows good conceptual understanding and mastery, with either minor errors or correct work with insufficient explanation or justification.
- Sample errors: an explanation that vertical angles cannot be complementary that includes visible evidence of understanding the definition and meaning of both terms; an explanation that adjacent angles cannot be supplementary that includes visible evidence of understanding the definition and meaning of both terms; an attempt to make two angles that are both complementary and supplementary that includes visible evidence of understanding the

definition and meaning of both terms; two intersecting lines without clearly marking which two angles are vertical and no marking of angle measures.

Tier 3 response:

- Work shows a developing but incomplete conceptual understanding, with significant errors.
- Sample errors: serious error(s) caused by a misunderstanding of one of the terms complementary, supplementary, vertical, adjacent; omission of one of the three parts.

Tier 4 response:

- Work includes major errors or omissions that demonstrate a lack of conceptual understanding and mastery.
- Sample errors: serious errors caused by misunderstanding of more than one of the terms; omission of two or more of the three parts.

Aligned Standards

7.G.B.5

CKMath™
Core Knowledge **MATHEMATICS™**



Lesson
Cool Downs

Lesson 1: Relationships of Angles

Cool Down: Identical Isosceles Triangles

Here are two different patterns made out of the same five identical isosceles triangles. Without using a protractor, determine the measures of $\angle x$ and $\angle y$. Explain or show your reasoning.

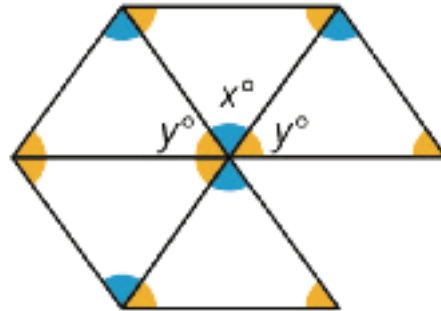
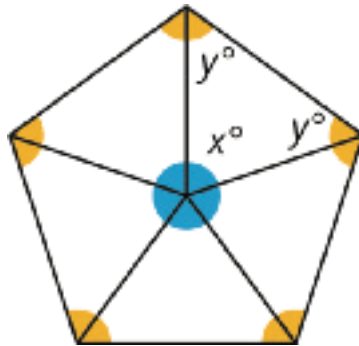

Lesson 2: Adjacent Angles

Cool Down: Finding Measurements

1. Point F is on line CD . Find the measure of angle CFE .

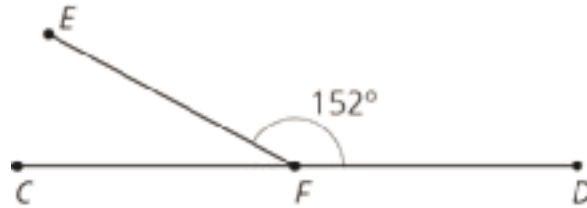

2. Angle SPR and angle RPQ are complementary. Find the measure of angle RPQ .

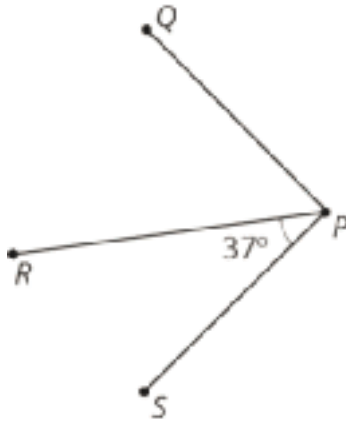

Lesson 3: Nonadjacent Angles

Cool Down: Finding Angle Pairs

1. Name *two pairs* of complementary angles in the diagram.

2. Name *two pairs* of supplementary angles in the diagram.

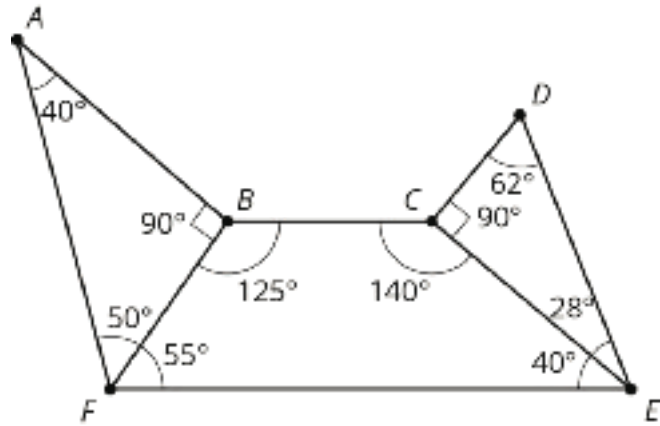

3. Draw another angle to make a pair of vertical angles. Label your new angle with its measure.

Lesson 4: Solving for Unknown Angles

Cool Down: Missing Circle Angles

AD , BE , and CF are all diameters of the circle. The measure of angle AOB is 40 degrees. The measure of angle DOF is 120 degrees.

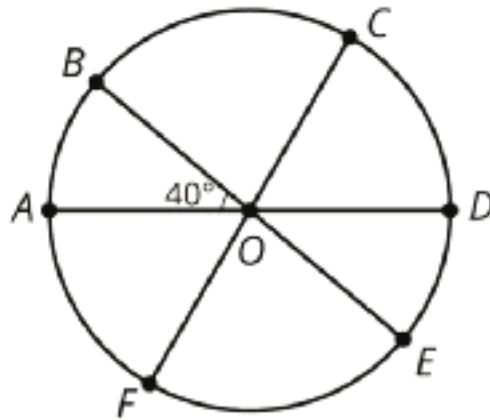

Find the measures of the angles:

1. BOC

2. COD

Lesson 5: Using Equations to Solve for Unknown Angles

Cool Down: In Words

Here are three intersecting lines.

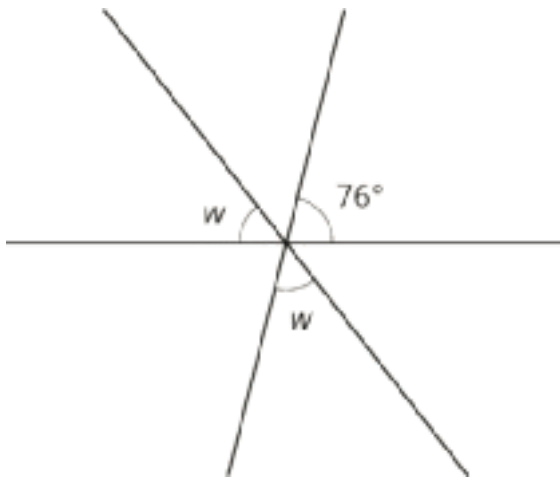

1. Write an equation that represents a relationship between these angles.
2. Describe, in words, the process you would use to find w .

Lesson 6: Building Polygons (Part 1)

Cool Down: An Equilateral Quadrilateral

When asked to draw a quadrilateral with all four sides measuring 5 cm, Jada drew a square.

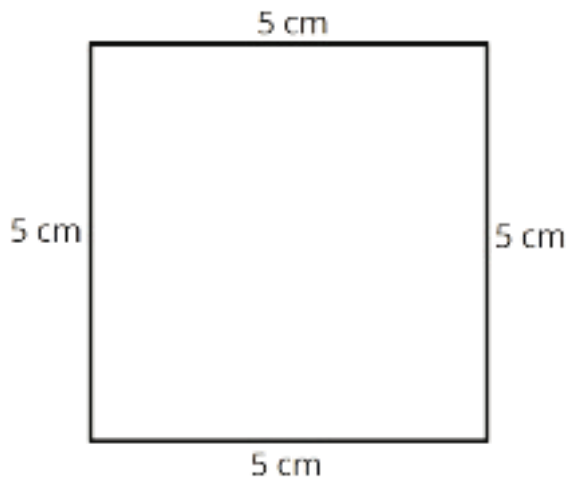

1. Do you agree with Jada's answer?
2. Is there a different shape Jada could have drawn that would answer the question? Explain your reasoning.

Lesson 7: Building Polygons (Part 2)

Cool Down: Finishing Elena's Triangles

Elena is trying to draw a triangle with side lengths 4 inches, 3 inches, and 5 inches.

- She uses her ruler to draw a 4 inch line segment AB .
- She uses her compass to draw a circle around point B with radius 3 inches
- She draws another circle, around point A with radius 5 inches.

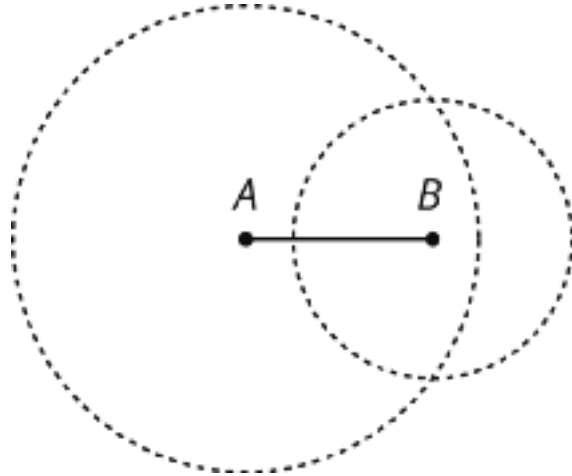

1. What should Elena do next? Explain and show how she can finish drawing the triangle.

Now Elena is trying to draw a triangle with side lengths 4 inches, 3 inches, and 8 inches.

- She uses her ruler to draw a 4 inch line segment AB .
- She uses her compass to draw a circle around point B with radius 3 inches.
- She draws another circle, around point A with radius 8 inches.

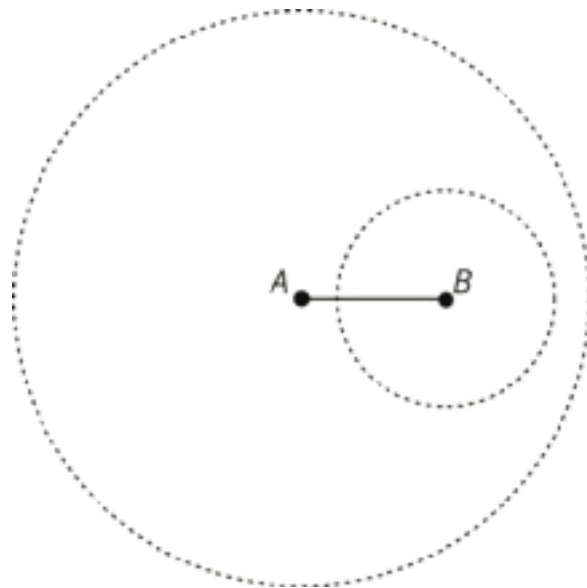

2. Explain what Elena's drawing means.

Lesson 8: Triangles with 3 Common Measures

Cool Down: Comparing Andre and Noah's Triangles

Andre and Noah each drew a triangle with side lengths of 5 cm and 3 cm and an angle that measures 60° , and then they showed each other their drawings.

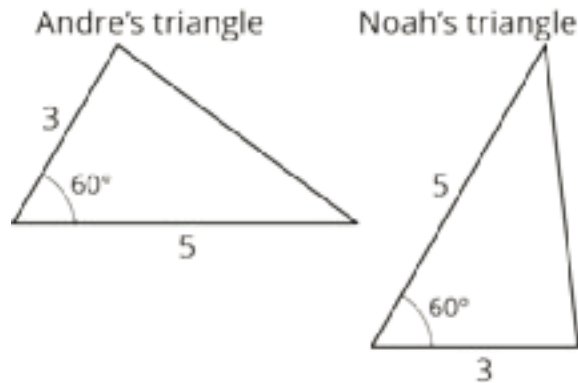

1. Did Andre and Noah draw different triangles? Explain your reasoning.

2. Explain what Andre and Noah would have to do to draw another triangle that is different from what either of them has already drawn.

Lesson 9: Drawing Triangles (Part 1)

Cool Down: Checking Diego's Triangle

When asked to draw a triangle with two 45° angles and a side length of 8 cm, Diego drew this triangle.

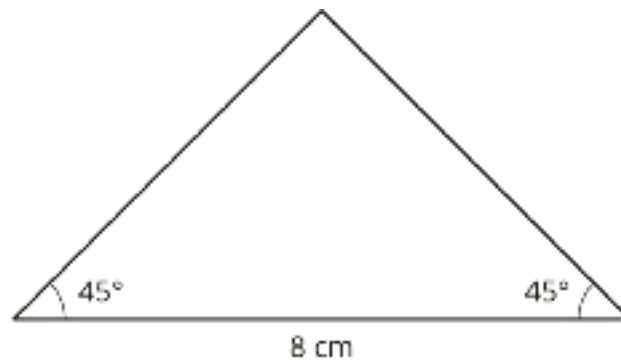

1. Do you agree with Diego's answer?
2. Is there a different triangle Diego could have drawn that would answer the question?
Explain or show your reasoning.

Lesson 10: Drawing Triangles (Part 2)

Cool Down: Finishing Noah's Triangle

Noah is trying to draw a triangle with a 30° angle and side lengths of 4 cm and 6 cm.

- He uses his ruler to draw a 4 cm line segment.
- He uses his protractor to draw a 30° angle on one end of the line segment.

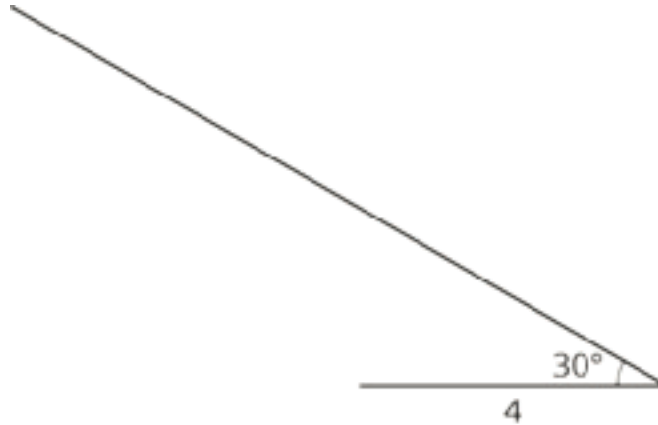

1. What should Noah do next? Explain and show how he can finish drawing the triangle.

2. Is there a different triangle Noah could draw that would answer the question? Explain or show your reasoning.

Lesson 11: Slicing Solids

Cool Down: Pentagonal Pyramid

Here is a pyramid with a base that is a pentagon with all sides the same length.

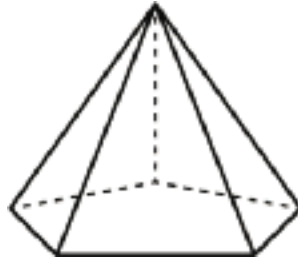

1. Describe the cross section that will result if the pyramid is sliced:
 - a. horizontally (parallel to the base).

 - b. vertically through the top vertex (perpendicular to the base).

2. Describe another way you could slice the pyramid that would result in a different cross section.

Lesson 12: Volume of Right Prisms

Cool Down: Octagonal Box

A box is shaped like an octagonal prism. Here is what the base of the prism looks like.

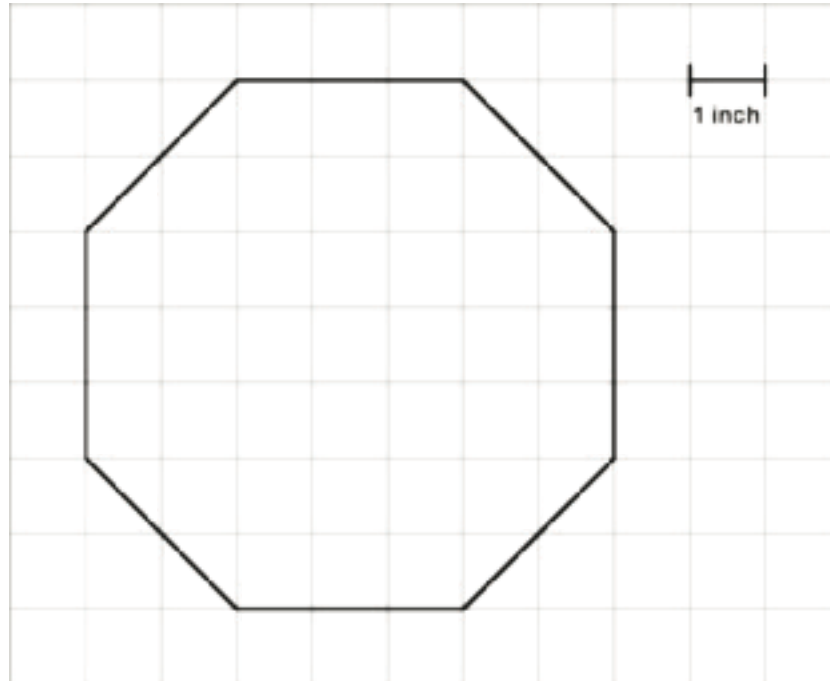

For each question, make sure to include the unit with your answer and explain or show your reasoning.

1. If the height of the box is 7 inches, what is the volume of the box?

2. If the volume of the box is 123 in^3 , what is the height of the box?

Lesson 13: Decomposing Bases for Area

Cool Down: Volume of a Pentagonal Prism

Here is a prism with a pentagonal base. The height is 8 cm.

What is the volume of the prism? Show your thinking. Organize it so it can be followed by others.

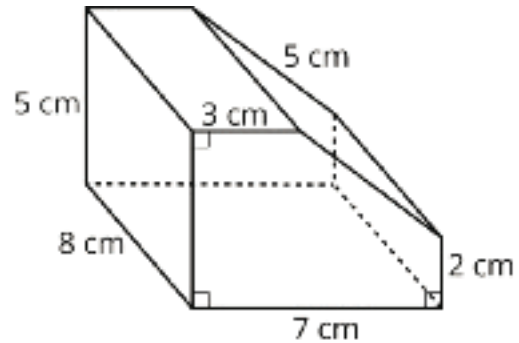

Lesson 14: Surface Area of Right Prisms

Cool Down: Surface Area of a Hexagonal Prism

Find the surface area of this prism. Show your reasoning. Organize it so it can be followed by others.

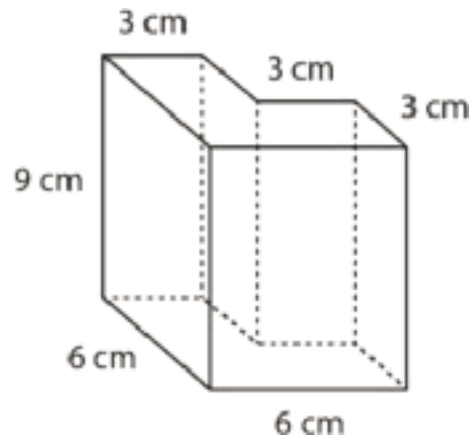

Lesson 15: Distinguishing Volume and Surface Area

Cool Down: Surface Area Differences

Describe some similarities and differences between a situation that involves calculating surface area and a situation that involves calculating volume.

CKMath™
Core Knowledge **MATHEMATICS™**



Instructional
Masters

Instructional Masters for Angles, Triangles, and Prisms

| address | title | students per copy | written on? | requires cutting? | card stock recommended? | color paper recommended? |
|------------------------|-----------------------------------|-------------------|-------------|-------------------|-------------------------|--------------------------|
| Activity Grade7.7.10.2 | Revisiting How Many Can You Draw? | 1 | no | no | no | no |
| Activity Grade7.7.17.3 | Making the Prism | 1 | yes | no | no | no |
| Activity Grade7.7.12.2 | Finding Volume with Cubes | 1 | no | yes | no | no |
| Activity Grade7.7.11.3 | Card Sort: Cross Sections | 1 | no | yes | no | no |
| Activity Grade7.7.15.3 | Card Sort: Surface Area or Volume | 1 | no | yes | no | no |
| Activity Grade7.7.4.2 | Info Gap: Angle Finding | 1 | no | yes | no | no |
| Activity Grade7.7.6.2 | What Can You Build? | 1 | no | yes | no | yes |
| Activity Grade7.7.12.3 | Can You Find the Volume? | 1 | no | yes | yes | no |
| Activity Grade7.7.14.1 | Multifaceted | 1 | no | no | no | no |
| Activity Grade7.7.7.3 | Swinging the Sides Around | 1 | yes | no | no | no |

Info Gap: Angle Finding

Problem Card 1

Find the measure of angle b .

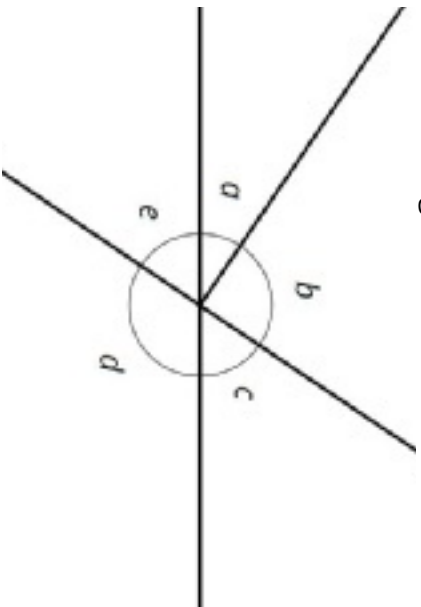

Info Gap: Angle Finding

Data Card 1

- Angles c and e are vertical angles.
- Angles a and c are complementary angles.
- The measure of angle $d = 124^\circ$.
- The measure of angle $c = 56^\circ$.

Info Gap: Angle Finding

Problem Card 2

Find the measure of angle b .

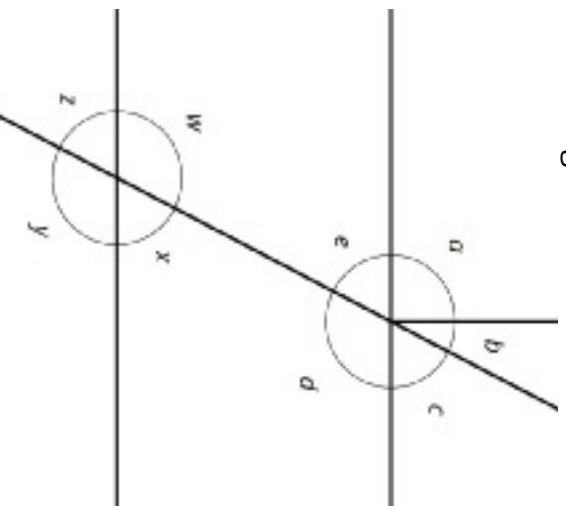

Info Gap: Angle Finding

Data Card 2

- The measure of angle $a = 90^\circ$.
- The measure of angle $z = 63^\circ$.
- Angles c and z are not vertical angles.
- Angles d and x are supplementary angles.

7.7.6.2 What Can You Build?.

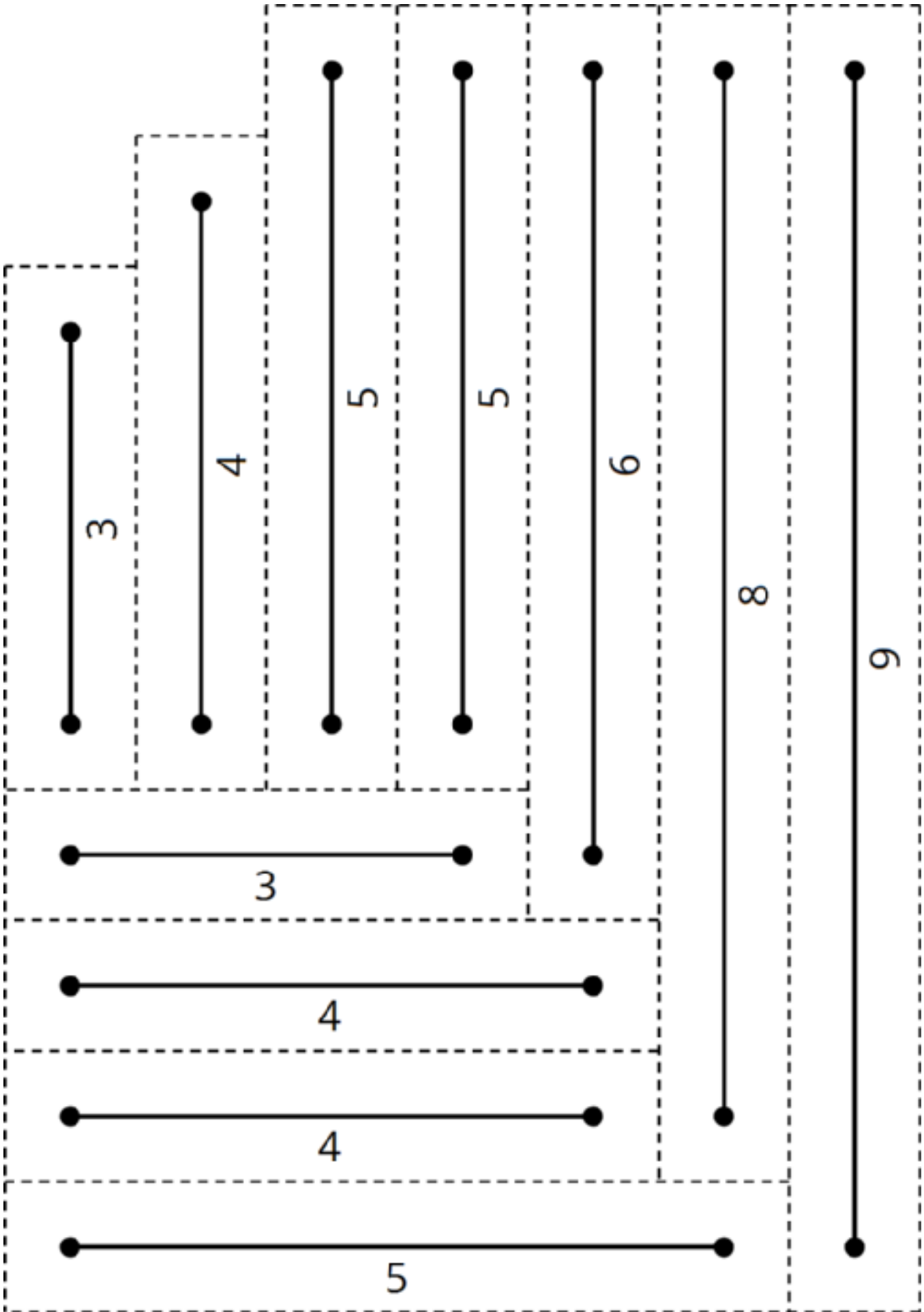

7.7.7.3 Swinging the Sides Around.

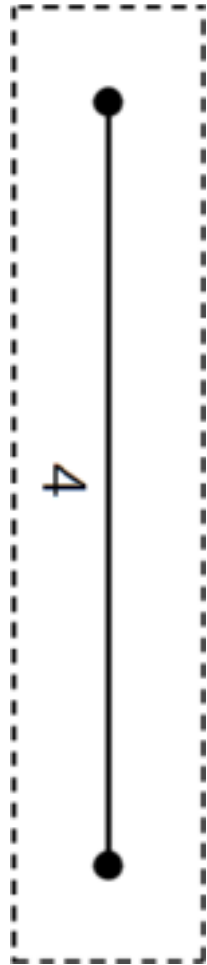

Set your compass to 5 cm and then draw an arc:

from the left end of the 4 cm segment

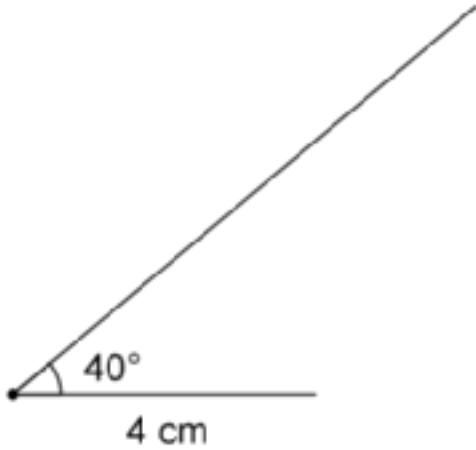

from the right end of the 4 cm segment

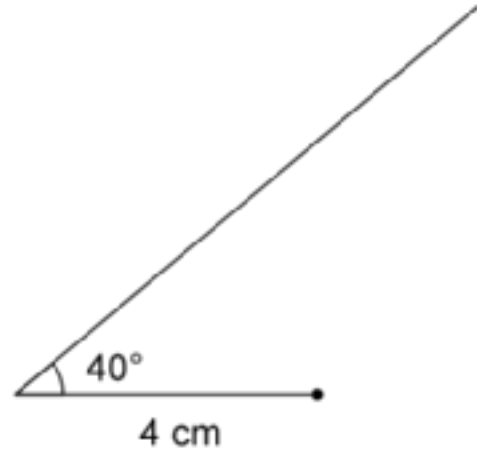

Set your compass to 4 cm and then draw an arc:

from the left end of the 5 cm segment

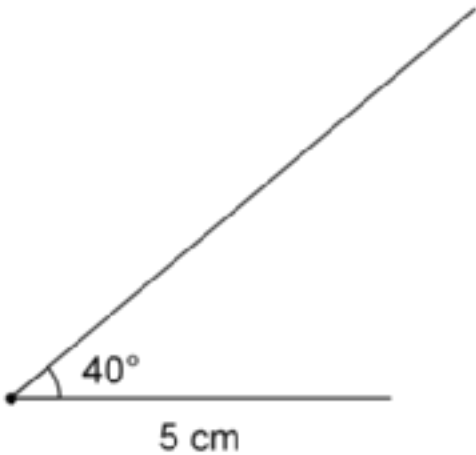

from the right end of the 5 cm segment

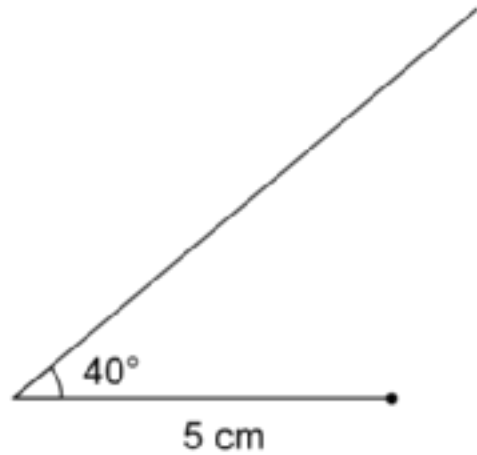

After you finish drawing and labeling each triangle, consider the following questions:

- Which two configurations made the same triangle?
- Which one configuration could make more than one triangle?

7.7.11.3 Card Sort: Cross Sections.

Card Sort: Cross Sections, Card A



Card Sort: Cross Sections, Card B

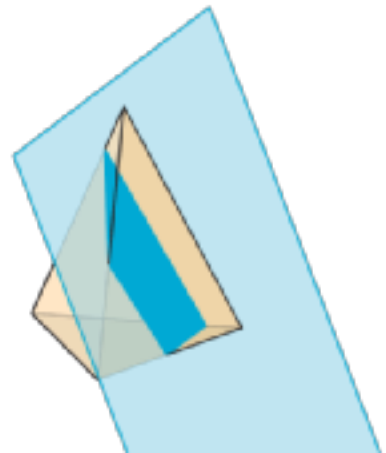

Card Sort: Cross Sections, Card C



Card Sort: Cross Sections, Card D

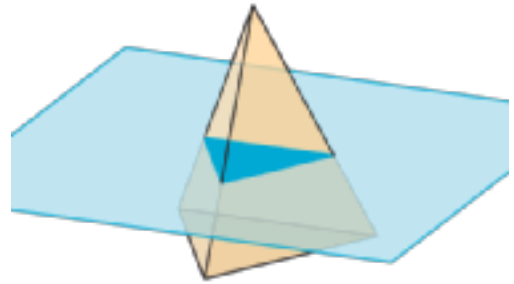

Card Sort: Cross Sections, Card E

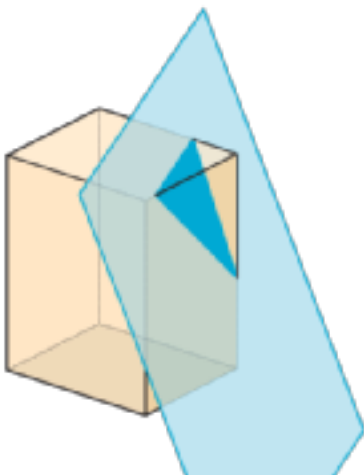

Card Sort: Cross Sections, Card F

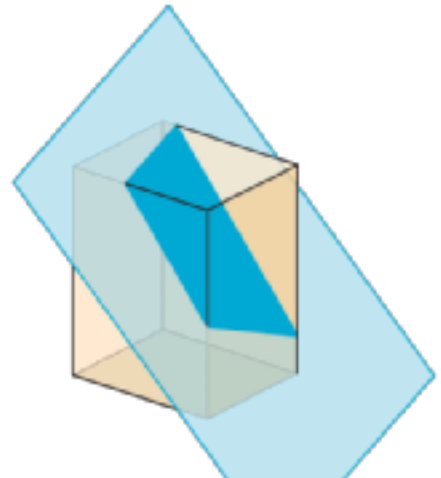

Card Sort: Cross Sections, Card G

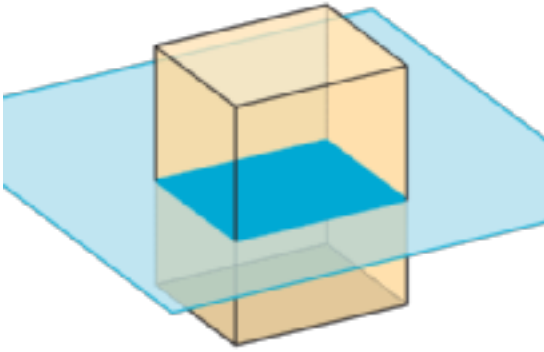

Card Sort: Cross Sections, Card H

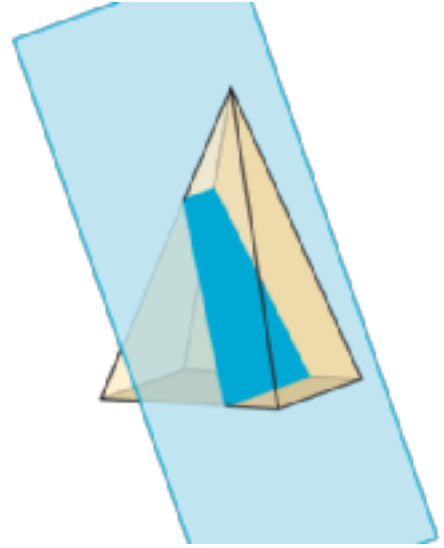

Card Sort: Cross Sections, Card I

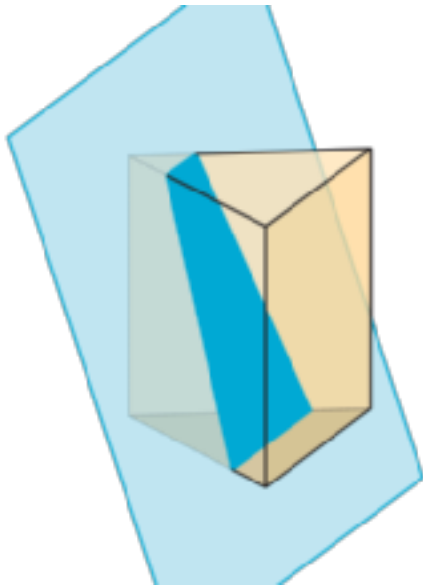

Card Sort: Cross Sections, Card J

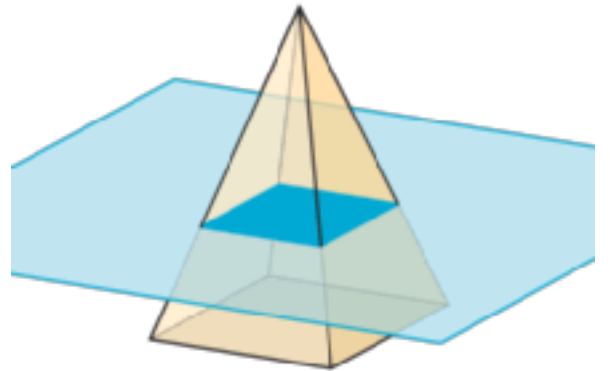

Card Sort: Cross Sections, Card K

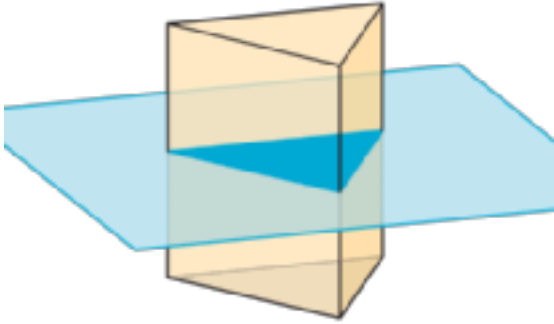

Card Sort: Cross Sections, Card L

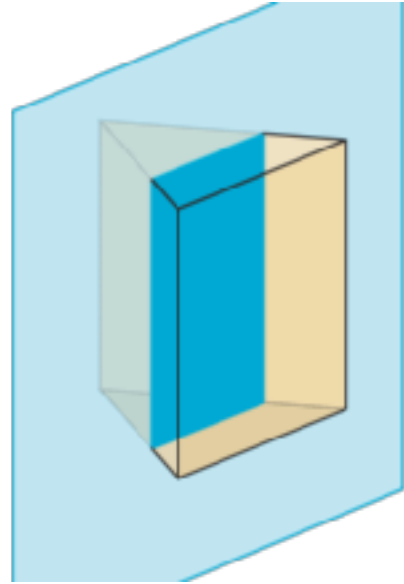

Card Sort: Cross Sections, Card M



7.7.12.2 Finding Volume with Cubes.

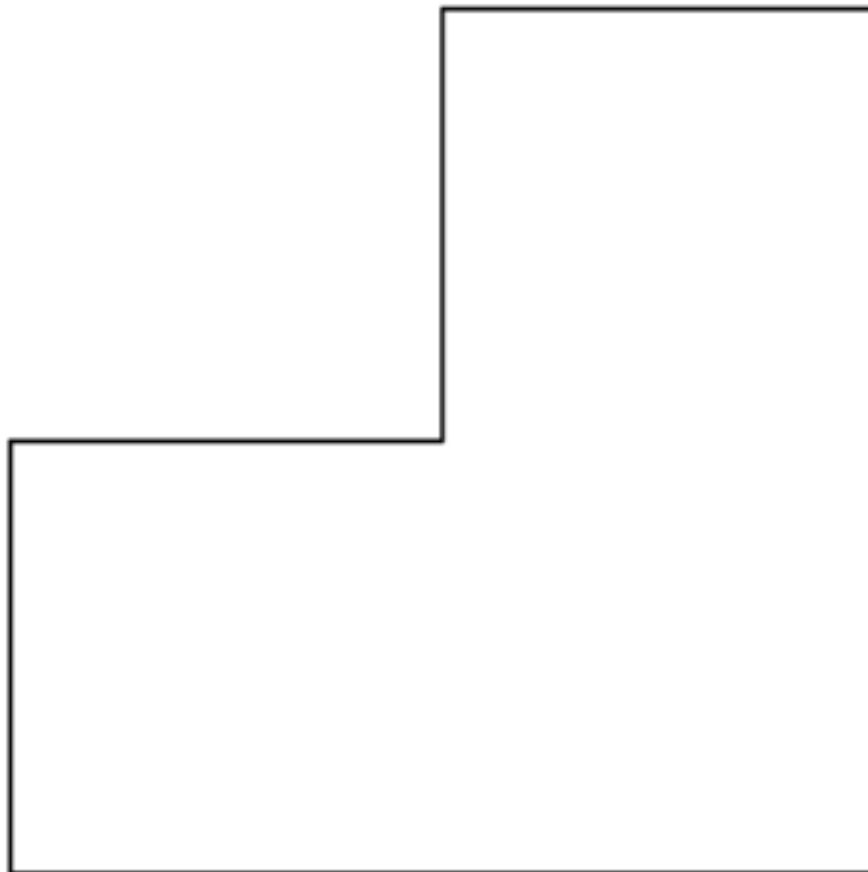
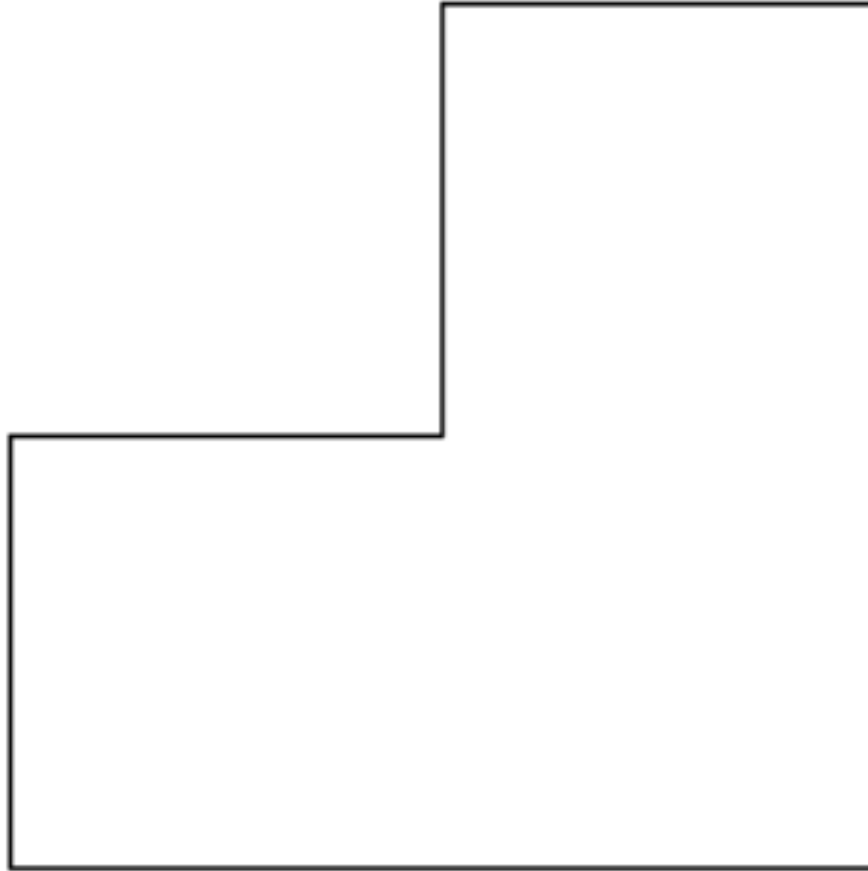

7.7.12.2 Finding Volume with Cubes.

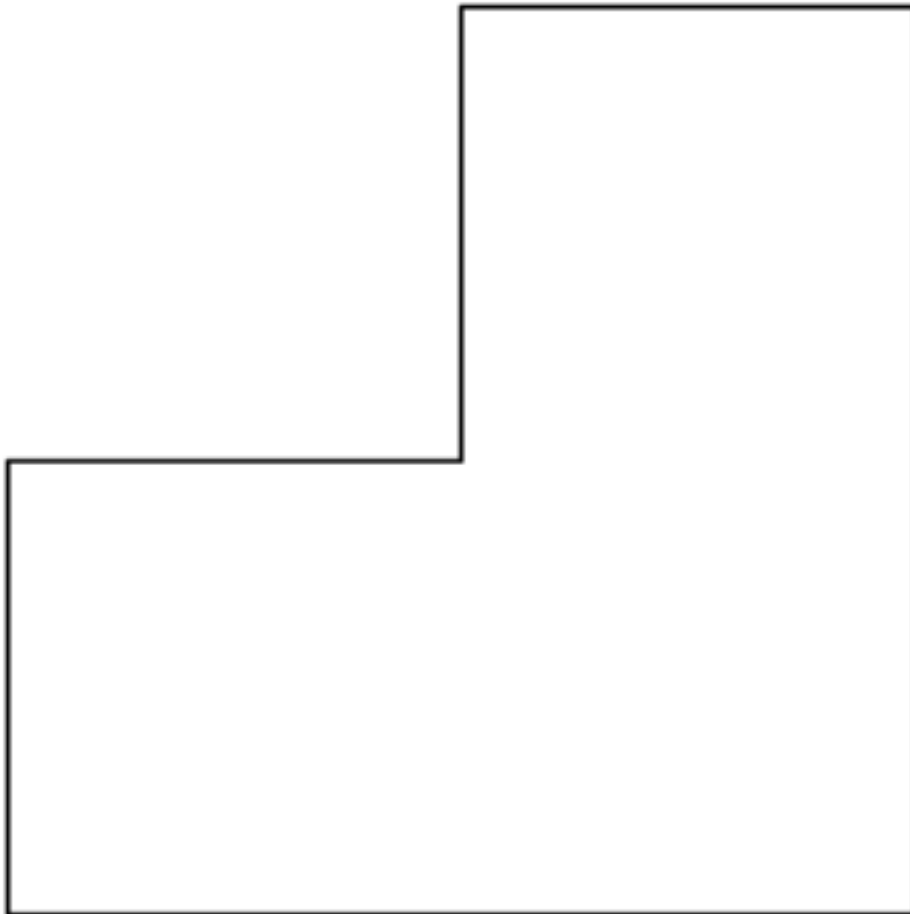
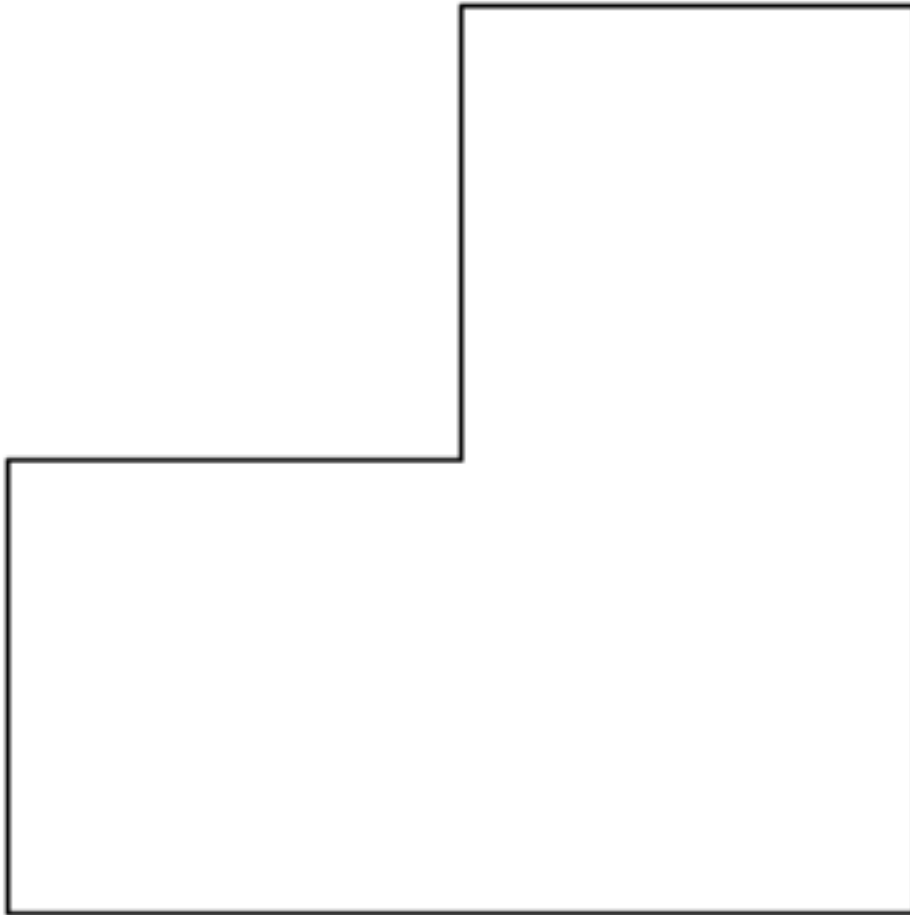

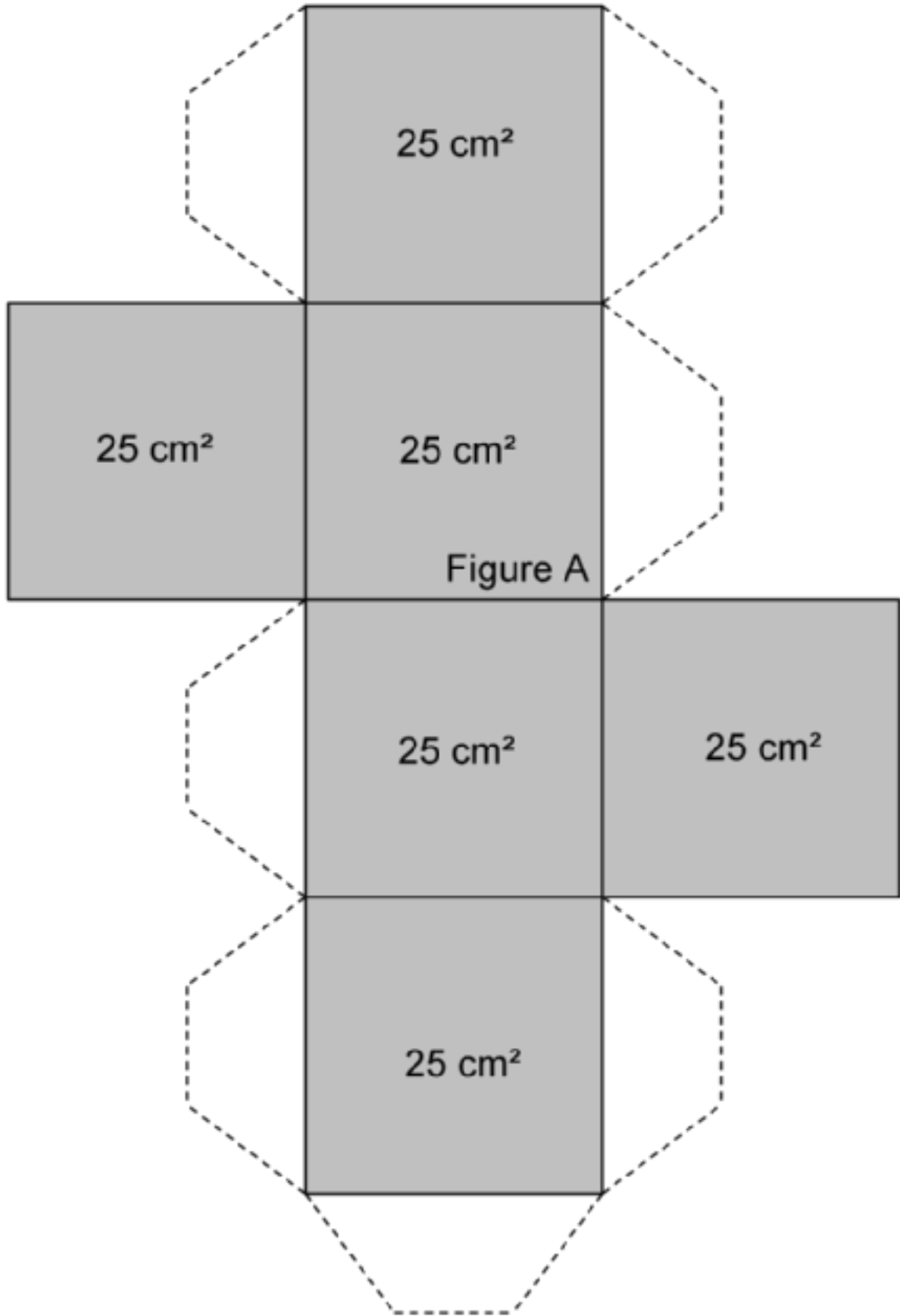

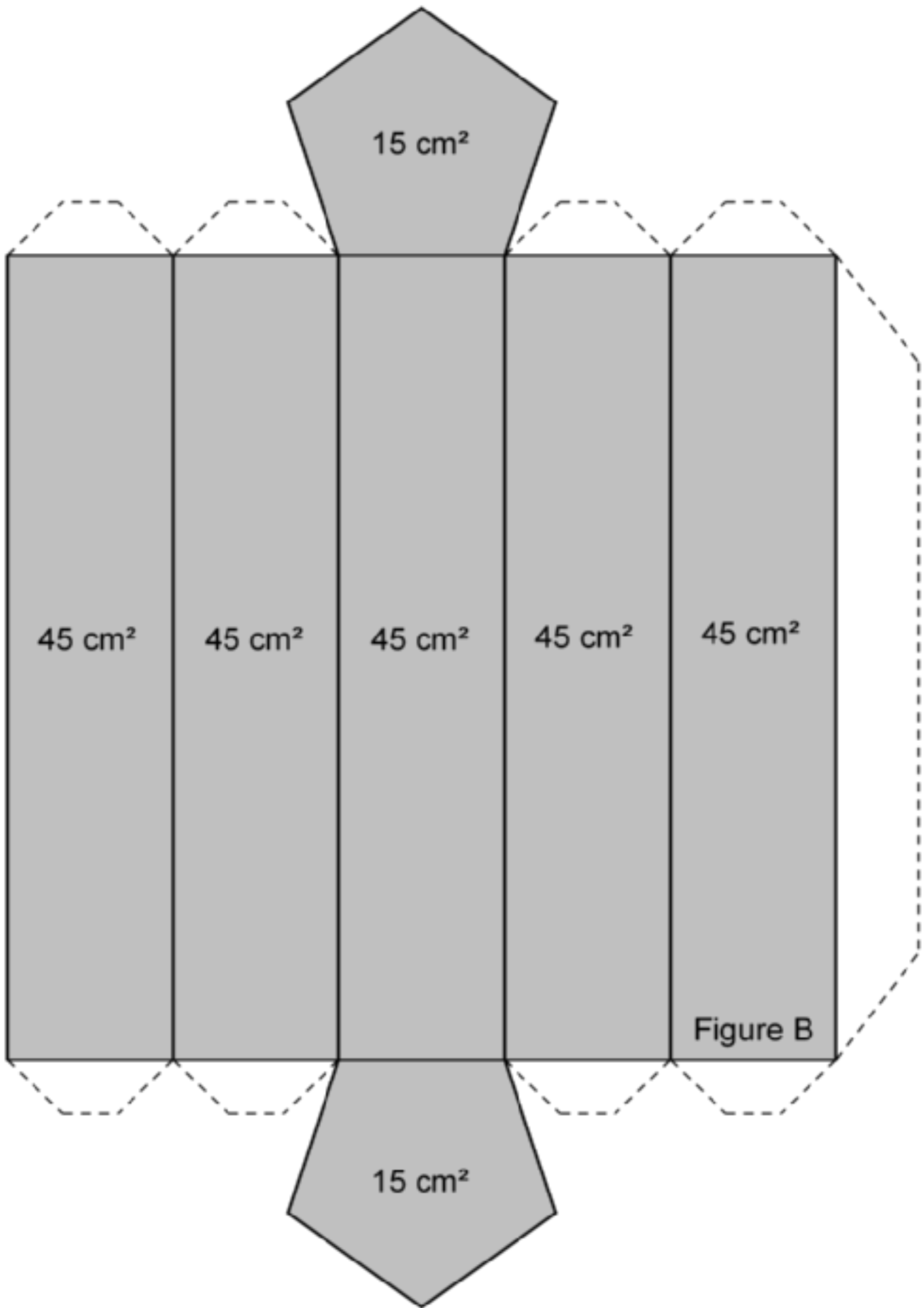

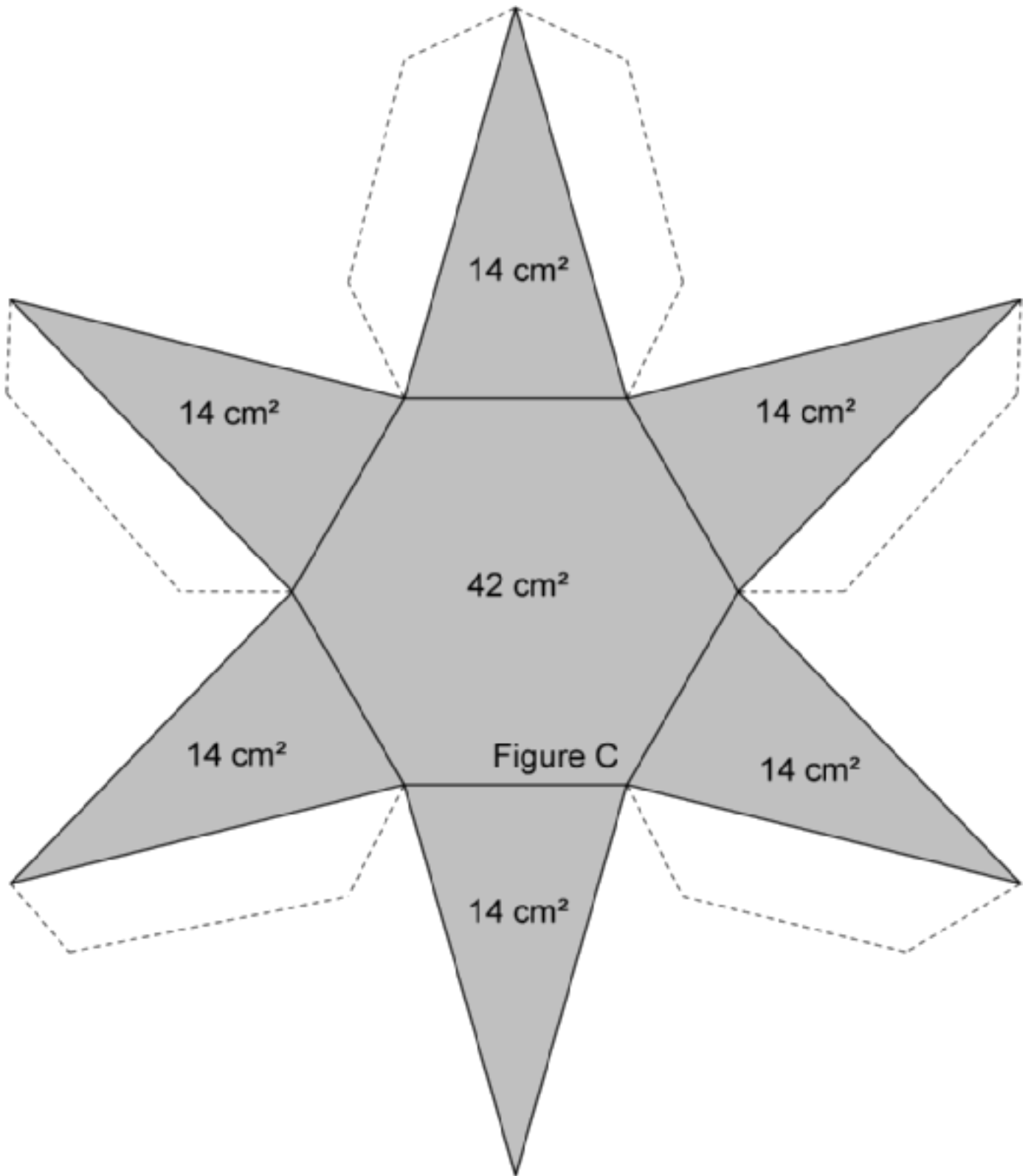

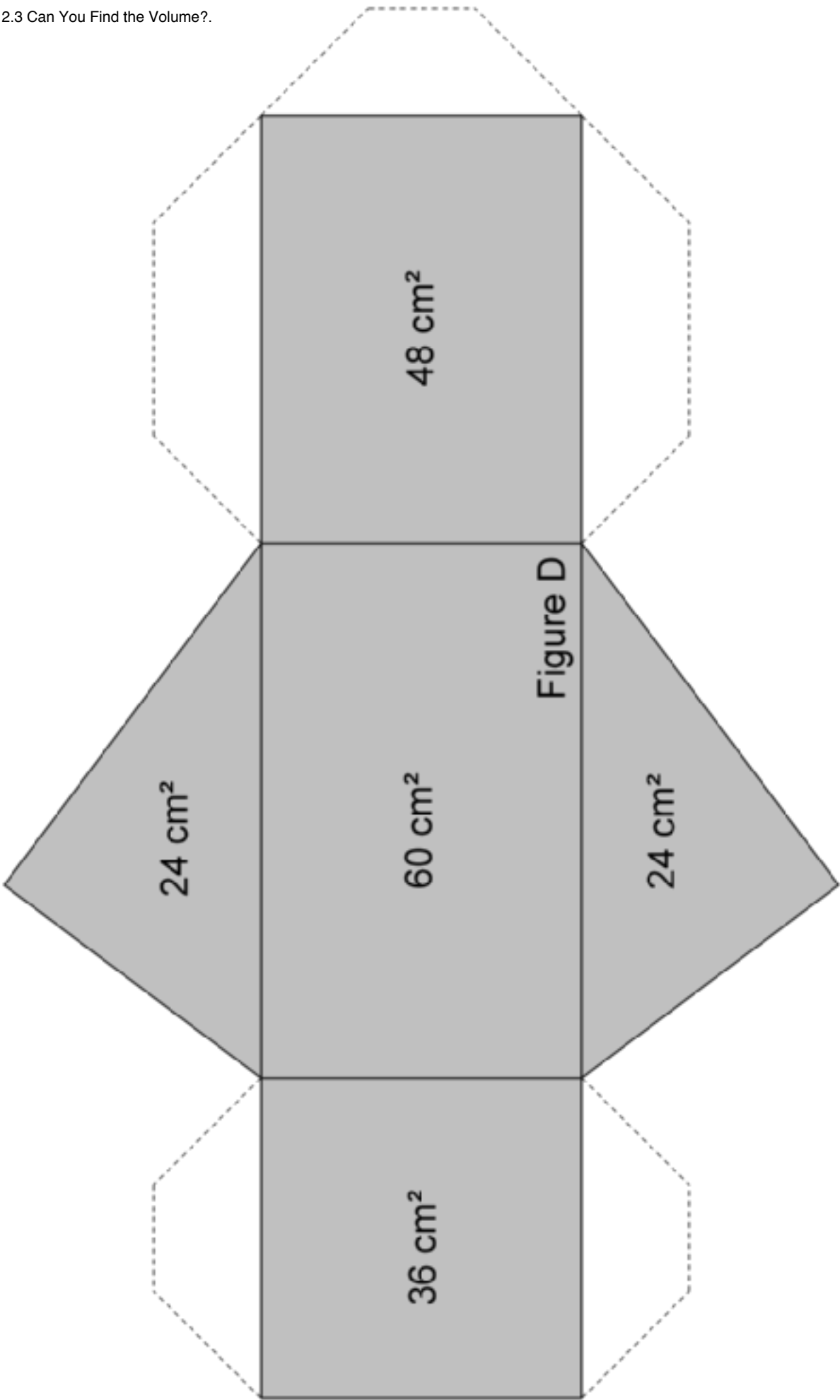

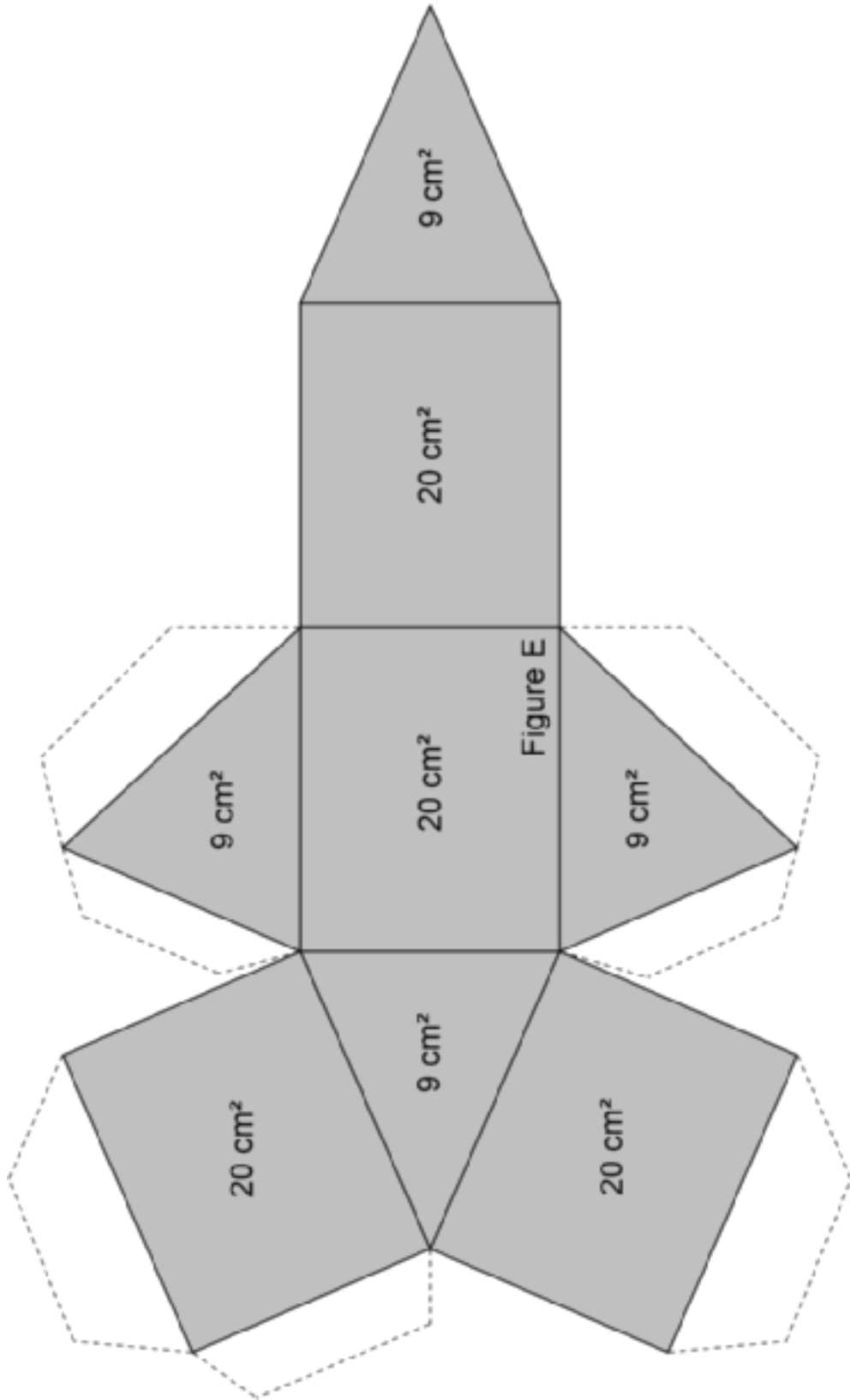

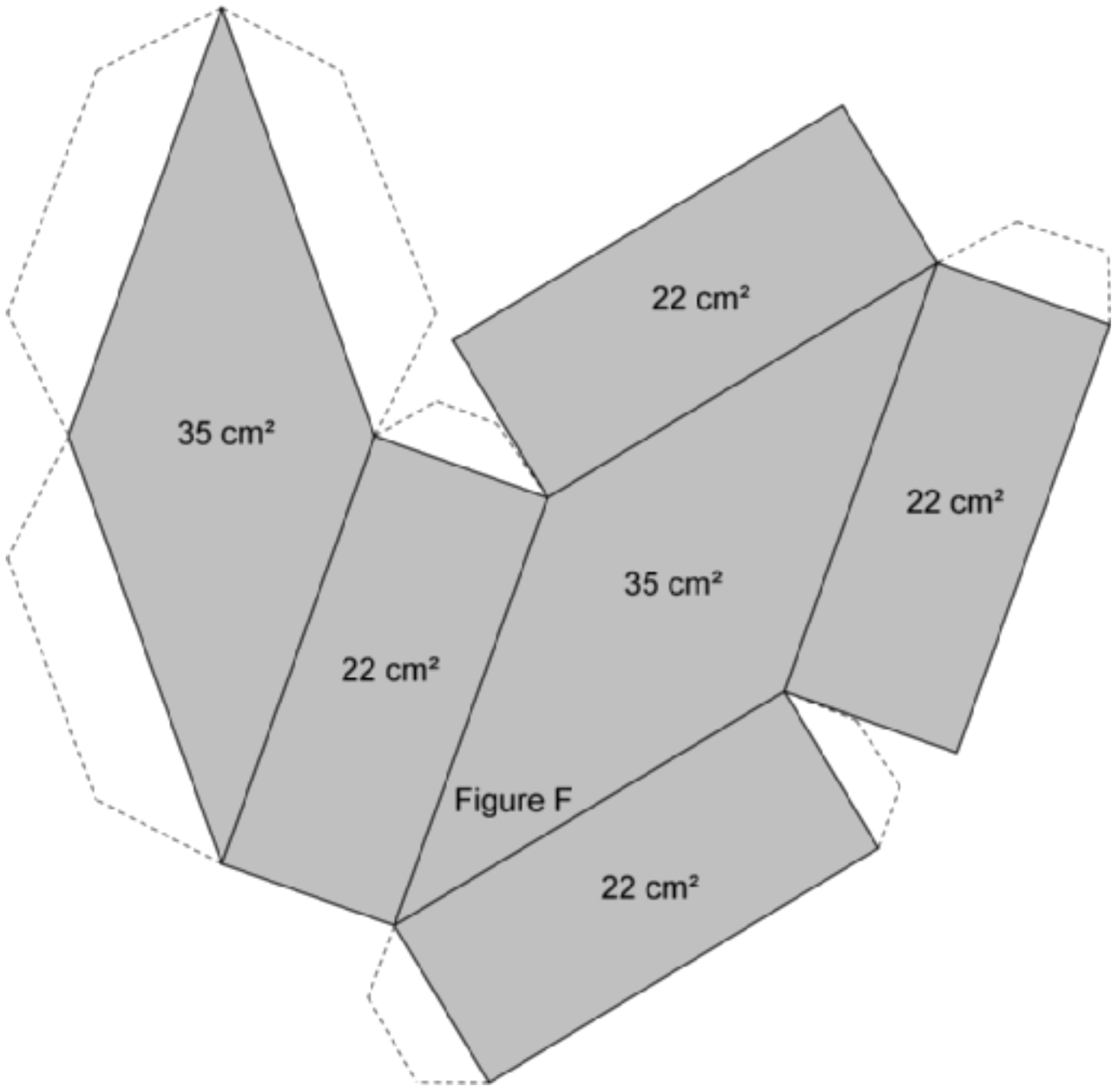

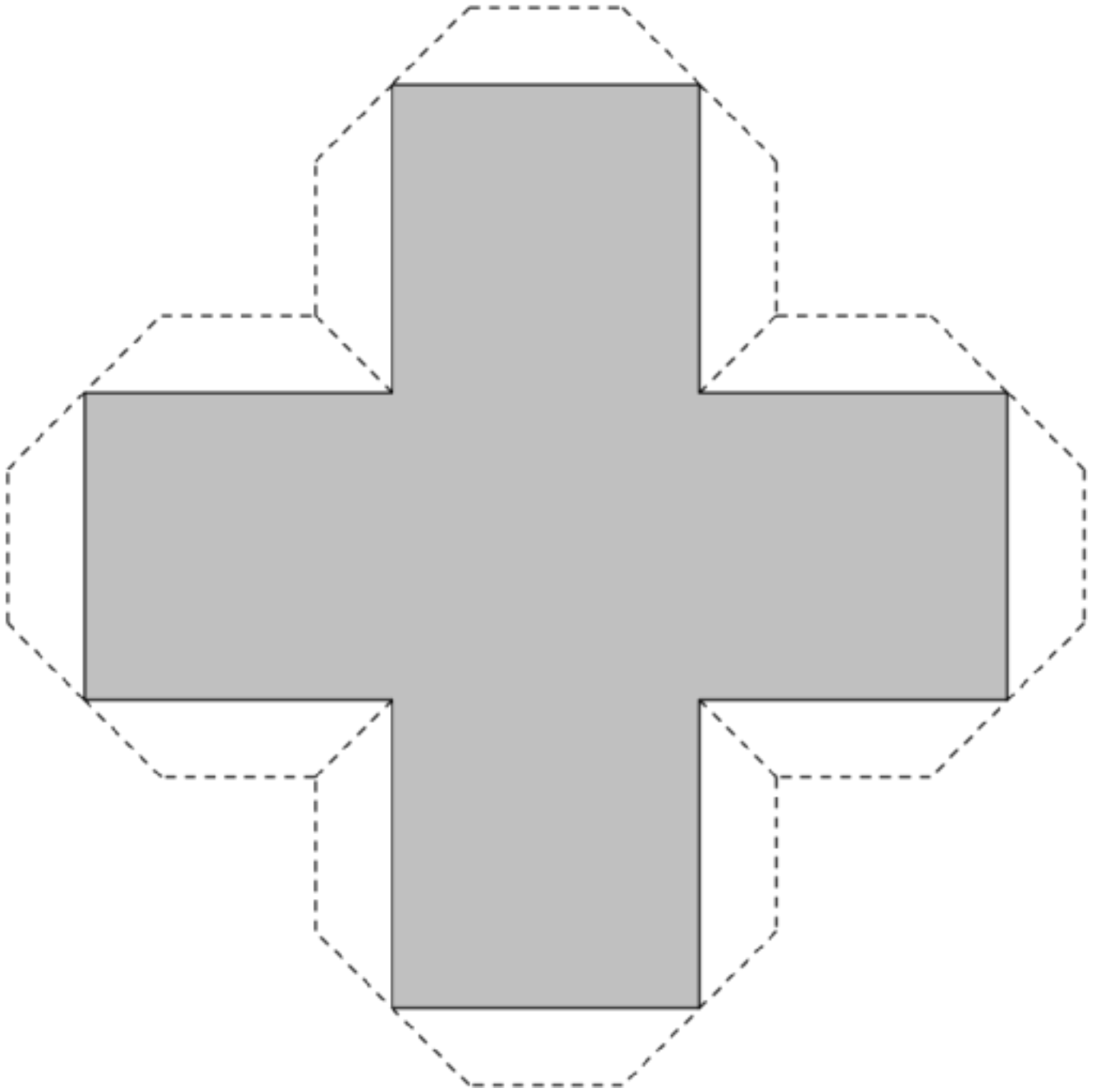

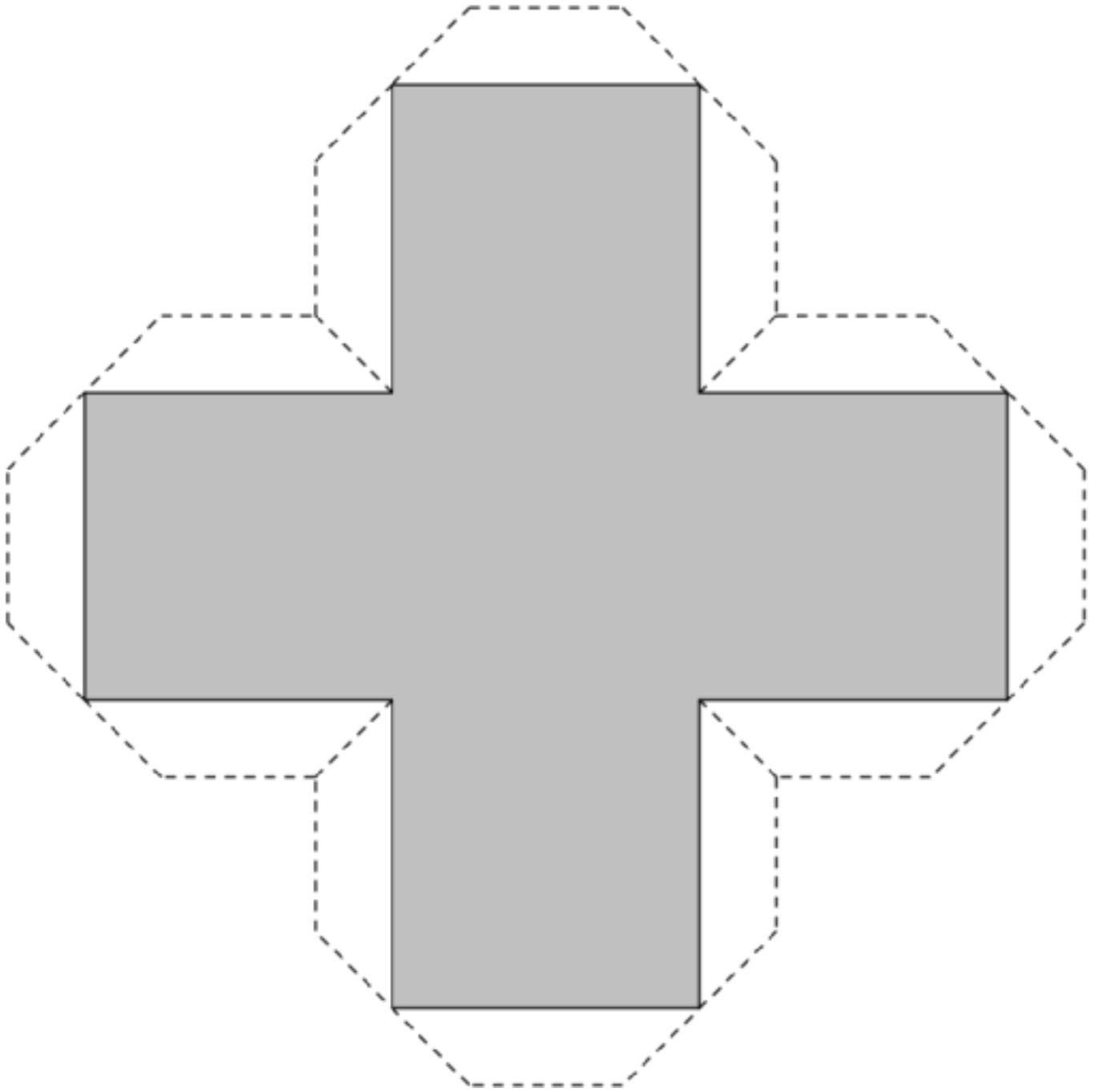

7.7.14.1 Multifaceted.

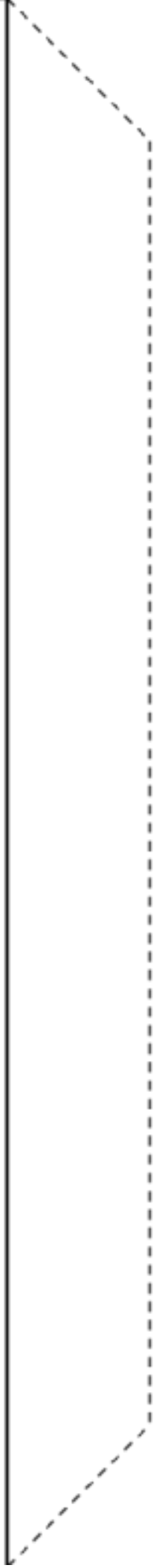

7.7.14.1 Multifaceted.

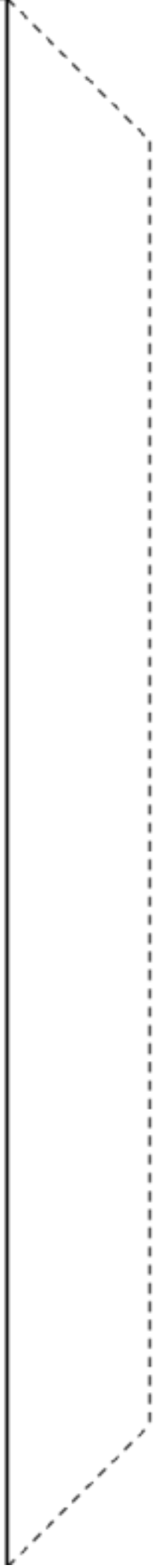

7.7.14.1 Multifaceted.

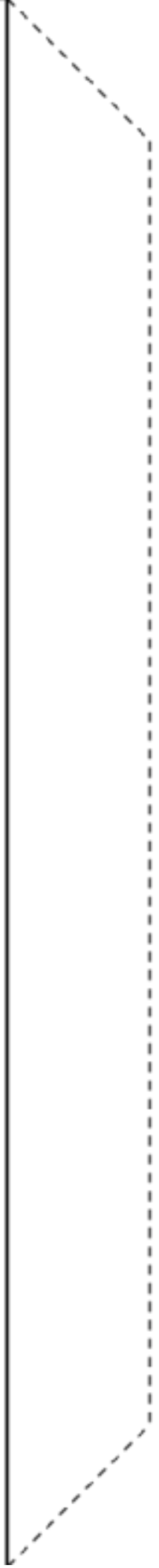

7.7.14.1 Multifaceted.

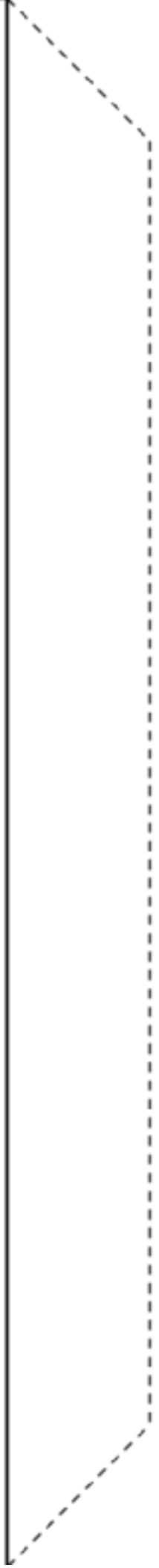

Card Sort: Surface Area or Volume

How much wood is needed to make triangular shaped stacking blocks?

Card Sort: Surface Area or Volume

How much glass is needed to build a greenhouse?

Card Sort: Surface Area or Volume

How long it would take to fill a rectangular swimming pool?

Card Sort: Surface Area or Volume

How long would it take to paint the outside of a barn?

Card Sort: Surface Area or Volume

How many yards of fabric needed to sew a pillowcase?

Card Sort: Surface Area or Volume

How much cardboard is needed to make a cereal box?

Card Sort: Surface Area or Volume

How long it would take to dig dirt out to form a rectangular foundation for a new building?

Card Sort: Surface Area or Volume

How much wood is needed to build a birdhouse?

7.7.17.3 Making the Prism.

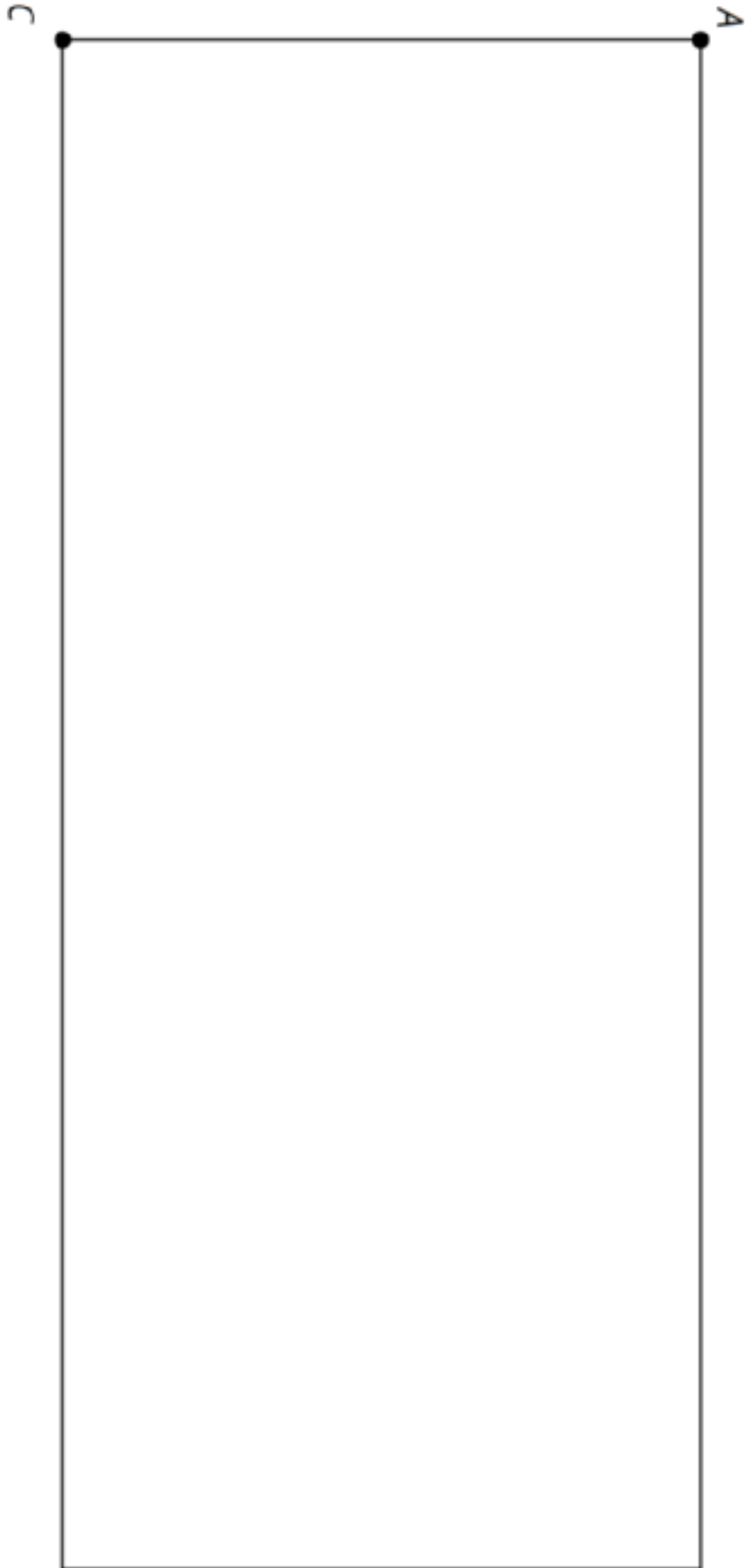

Credits

CKMath K–8 was originally developed by Open Up Resources and authored by Illustrative Mathematics, <https://www.illustrativemathematics.org>, and is copyrighted as 2017–2019 by Open Up Resources. It is licensed under the Creative Commons Attribution 4.0 International License (CC BY 4.0). The Open Up Resources K–8 Math Curriculum is available at: <https://www.openupresources.org/math-curriculum/>.

Adaptations and updates to the IM K–8 Math English language learner supports are copyright 2019 by Open Up Resources and licensed under the Creative Commons Attribution 4.0 International License (CC BY 4.0),

Adaptations and updates to IM K–8 Math are copyright 2019 by Illustrative Mathematics, including the additional English assessments marked as "B", and the Spanish translation of assessments marked as "B". These adaptations and updates are licensed under the Creative Commons Attribution 4.0 International License (CC BY 4.0).

This particular work is based on additional work of the Core Knowledge® Foundation (www.coreknowledge.org) made available through licensing under a Creative Commons Attribution-NonCommercial-ShareAlike 4.0 International License.

Illustration and Photo Credits

Ivan Pestic / Cover Illustrations

Illustrative Math K–8 / Cover Image, all interior illustrations, diagrams, and pictures / Copyright 2019 / Licensed under the Creative Commons Attribution 4.0 International License (CC BY 4.0).

These materials include public domain images or openly licensed images that are copyrighted by their respective owners, unless otherwise noted/credited. Openly licensed images remain under the terms of their respective licenses.



CKMath™
Core Knowledge **MATHEMATICS™**

CKMath™
Core Knowledge MATHEMATICS™

A comprehensive program for mathematical skills and concepts
as specified in the **Core Knowledge Sequence**
(content and skill guidelines for Grades K–8).

Core Knowledge MATHEMATICS™
units at this level include:

Scale Drawings
Introducing Proportional Relationships
Measuring Circles
Proportional Relationships and Percentages
Rational Number Arithmetic
Expressions, Equations, and Inequalities
Angles, Triangles, and Prisms
Probability and Sampling
Putting It All Together

www.coreknowledge.org

Core Knowledge Curriculum Series™