

Expressions, Equations, and Inequalities

Student Workbook

Tape Diagram

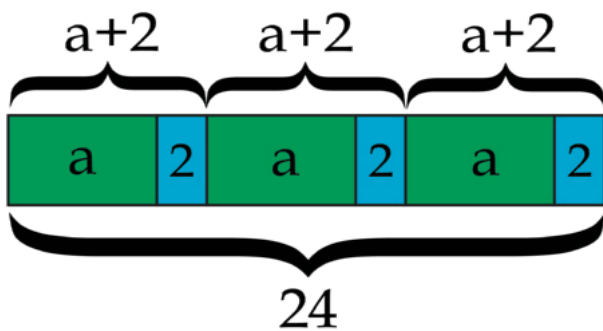

Make a Koch snowflake



Which Cupon to use?



Calculating Height

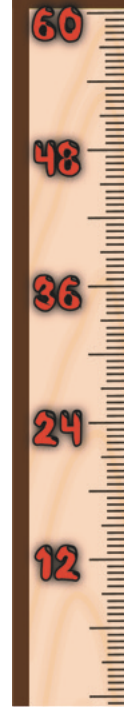

Creative Commons Licensing

This work is licensed under a Creative Commons Attribution-NonCommercial-ShareAlike 4.0 International License.



You are free:

- to Share**—to copy, distribute, and transmit the work
- to Remix**—to adapt the work

Under the following conditions:

Attribution—You must attribute the work in the following manner:
CKMath 6–8 was originally developed by Open Up Resources and authored by Illustrative Mathematics, <https://www.illustrativemathematics.org>, and is copyrighted as 2017–2019 by Open Up Resources. It is licensed under the Creative Commons Attribution 4.0 International License (CC BY 4.0). The Open Up Resources 6–8 Math Curriculum is available at: <https://www.openupresources.org/math-curriculum/>.

Adaptations and updates to the IM 6–8 Math English language learner supports and the additional English assessments marked as "B" are copyright 2019 by Open Up Resources and licensed under the Creative Commons Attribution 4.0 International License (CC BY 4.0).

Adaptations and updates to the IM K–8 Math Spanish translation of assessments marked as "B" are copyright 2019 by Illustrative Mathematics. These adaptations and updates are licensed under the Creative Commons Attribution 4.0 International License (CC BY 4.0).

This particular work is based on additional work of the Core Knowledge® Foundation (www.coreknowledge.org) made available through licensing under a Creative Commons Attribution-Non Commercial-Share Alike 4.0 International License. This does not in any way imply that the Core Knowledge Foundation endorses this work.

Noncommercial—You may not use this work for commercial purposes.

Share Alike—If you alter, transform, or build upon this work, you may distribute the resulting work only under the same or similar license to this one.

With the understanding that:

For any reuse or distribution, you must make clear to others the license terms of this work. The best way to do this is with a link to this web page:

<https://creativecommons.org/licenses/by-nc-sa/4.0/>

Copyright © 2023 Core Knowledge Foundation
www.coreknowledge.org

All Rights Reserved.

Core Knowledge®, Core Knowledge Curriculum Series™, Core Knowledge Math™ and CKMath™ are trademarks of the Core Knowledge Foundation.

Trademarks and trade names are shown in this book strictly for illustrative and educational purposes and are the property of their respective owners. References herein should not be regarded as affecting the validity of said trademarks and trade names.

Expressions, Equations, and Inequalities

Table of Contents

Lesson 1	Relationships between Quantities	1
Lesson 2	Reasoning about Contexts with Tape Diagrams	5
Lesson 3	Reasoning about Equations with Tape Diagrams	11
Lesson 4	Reasoning about Equations and Tape Diagrams (Part 1) 17	
Lesson 5	Reasoning about Equations and Tape Diagrams (Part 2) 23	
Lesson 6	Distinguishing between Two Types of Situations	28
Lesson 7	Reasoning about Solving Equations (Part 1)	33
Lesson 8	Reasoning about Solving Equations (Part 2)	40
Lesson 9	Dealing with Negative Numbers	47
Lesson 10	Different Options for Solving One Equation	53
Lesson 11	Using Equations to Solve Problems	59
Lesson 12	Solving Problems about Percent Increase or Decrease ..	65
Lesson 13	Reintroducing Inequalities	71
Lesson 14	Finding Solutions to Inequalities in Context	76
Lesson 15	Efficiently Solving Inequalities	82
Lesson 16	Interpreting Inequalities	88
Lesson 17	Modeling with Inequalities	94
Lesson 18	Subtraction in Equivalent Expressions	99
Lesson 19	Expanding and Factoring	104
Lesson 20	Combining Like Terms (Part 1)	110
Lesson 21	Combining Like Terms (Part 2)	116
Lesson 22	Combining Like Terms (Part 3)	121
Lesson 23	Applications of Expressions	126



Expressions, Equations, and Inequalities
Student Workbook

Core Knowledge Mathematics™

Lesson 1: Relationships between Quantities

Let's try to solve some new kinds of problems.

1.1: Pricing Theater Popcorn

A movie theater sells popcorn in bags of different sizes. The table shows the volume of popcorn and the price of the bag.

Complete one column of the table with prices where popcorn is priced at a constant rate. That is, the amount of popcorn is proportional to the price of the bag. Then complete the other column with realistic example prices where the amount of popcorn and price of the bag are not in proportion.

volume of popcorn (ounces)	price of bag, proportional (\$)	price of bag, not proportional (\$)
10	6	6
20		
35		
48		

1.2: Entrance Fees

A state park charges an entrance fee based on the number of people in a vehicle. A car containing 2 people is charged \$14, a car containing 4 people is charged \$20, and a van containing 8 people is charged \$32.

1. How much do you think a bus containing 30 people would be charged?
2. If a bus is charged \$122, how many people do you think it contains?
3. What rule do you think the state park uses to decide the entrance fee for a vehicle?

1.3: Making Toast

A toaster has 4 slots for bread. Once the toaster is warmed up, it takes 35 seconds to make 4 slices of toast, 70 seconds to make 8 slices, and 105 seconds to make 12 slices.

1. How long do you think it will take to make 20 slices?
2. If someone makes as many slices of toast as possible in 4 minutes and 40 seconds, how many slices do think they can make?

Are you ready for more?

What is the smallest number that has a remainder of 1, 2, and 3 when divided by 2, 3, and 4, respectively? Are there more numbers that have this property?

Lesson 1 Summary

In much of our previous work that involved relationships between two quantities, we were often able to describe amounts as being so much more than another, or so many times as much as another. We wrote equations like $x + 3 = 8$ and $4x = 20$ and solved for unknown amounts.

In this unit, we will see situations where relationships between amounts involve more operations. For example, a pizza store might charge the amounts shown in the table for delivering pies.

number of pies	total cost in dollars
1	13
2	23
3	33
5	53

We can see that each additional pie adds \$10 to the total cost, and that each total includes a \$3 additional cost, maybe representing a delivery fee. In this situation, 8 pies will cost $8 \cdot 10 + 3$ and a total cost of \$63 means 6 pies were ordered.

In this unit, we will see many situations like this one, and will learn how to use diagrams and equations to answer questions about unknown amounts.

Unit 6 Lesson 1 Cumulative Practice Problems

1. Lin and Tyler are drawing circles. Tyler's circle has twice the diameter of Lin's circle. Tyler thinks that his circle will have twice the area of Lin's circle as well. Do you agree with Tyler?

(From Unit 3, Lesson 7.)

2. Jada and Priya are trying to solve the equation $\frac{2}{3} + x = 4$.
 - Jada says, "I think we should multiply each side by $\frac{3}{2}$ because that is the reciprocal of $\frac{2}{3}$."
 - Priya says, "I think we should add $-\frac{2}{3}$ to each side because that is the opposite of $\frac{2}{3}$."
 - a. Which person's strategy should they use? Why?
 - b. Write an equation that can be solved using the other person's strategy.

(From Unit 5, Lesson 15.)

3. What are the missing operations?
 - a. $48 ? (-8) = (-6)$
 - b. $(-40) ? 8 = (-5)$
 - c. $12 ? (-2) = 14$
 - d. $18 ? (-12) = 6$
 - e. $18 ? (-20) = -2$
 - f. $22 ? (-0.5) = -11$

(From Unit 5, Lesson 13.)

4. In football, the team that has the ball has four chances to gain at least ten yards. If they don't gain at least ten yards, the other team gets the ball. Positive numbers represent a gain and negative numbers represent a loss. Select **all** of the sequences of four plays that result in the team getting to keep the ball.

- A. 8, -3, 4, 21
- B. 30, -7, -8, -12
- C. 2, 16, -5, -3
- D. 5, -2, 20, -1
- E. 20, -3, -13, 2

(From Unit 5, Lesson 14.)

5. A sandwich store charges \$20 to have 3 turkey subs delivered and \$26 to have 4 delivered.

- a. Is the relationship between number of turkey subs delivered and amount charged proportional? Explain how you know.
- b. How much does the store charge for 1 additional turkey sub?
- c. Describe a rule for determining how much the store charges based on the number of turkey subs delivered.

6. Which question cannot be answered by the solution to the equation $3x = 27$?

- A. Elena read three times as many pages as Noah. She read 27 pages. How many pages did Noah read?
- B. Lin has 27 stickers. She gives 3 stickers to each of her friends. With how many friends did Lin share her stickers?
- C. Diego paid \$27 to have 3 pizzas delivered and \$35 to have 4 pizzas delivered. What is the price of one pizza?
- D. The coach splits a team of 27 students into 3 groups to practice skills. How many students are in each group?

Lesson 2: Reasoning about Contexts with Tape Diagrams

Let's use tape diagrams to make sense of different kinds of stories.

2.1: Notice and Wonder: Remembering Tape Diagrams

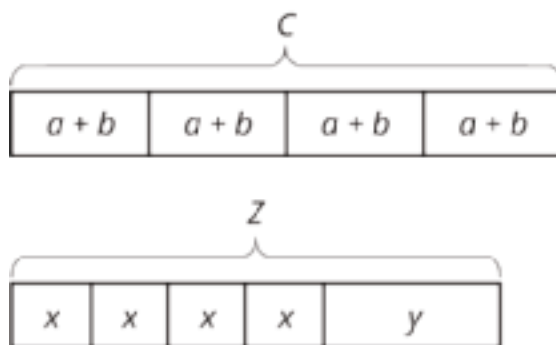

1. What do you notice? What do you wonder?

2. What are some possible values for a , b , and c in the first diagram?

For x , y , and z in the second diagram? How did you decide on those values?

2.2: Every Picture Tells a Story

Here are three stories with a diagram that represents it. With your group, decide who will go first. That person explains why the diagram represents the story. Work together to find any unknown amounts in the story. Then, switch roles for the second diagram and switch again for the third.

1. Mai made 50 flyers for five volunteers in her club to hang up around school. She gave 5 flyers to the first volunteer, 18 flyers to the second volunteer, and divided the remaining flyers equally among the three remaining volunteers.

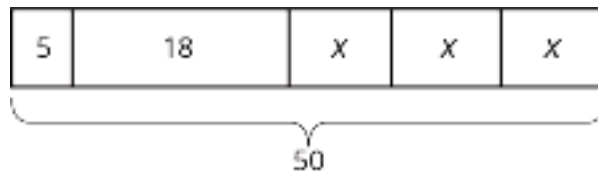

2. To thank her five volunteers, Mai gave each of them the same number of stickers. Then she gave them each two more stickers. Altogether, she gave them a total of 30 stickers.

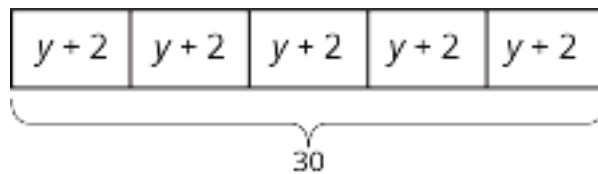

3. Mai distributed another group of flyers equally among the five volunteers. Then she remembered that she needed some flyers to give to teachers, so she took 2 flyers from each volunteer. Then, the volunteers had a total of 40 flyers to hang up.

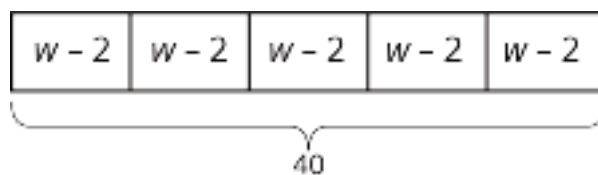

Are you ready for more?

Design a tiling that uses a repeating pattern consisting of 2 kinds of shapes (e.g., 1 hexagon with 3 triangles forming a triangle). How many times did you repeat the pattern in your picture? How many individual shapes did you use?

Lesson 2 Summary

Tape diagrams are useful for representing how quantities are related and can help us answer questions about a situation.

Suppose a school receives 46 copies of a popular book. The library takes 26 copies and the remainder are split evenly among 4 teachers. How many books does each teacher receive? This situation involves 4 equal parts and one other part. We can represent the situation with a rectangle labeled 26 (books given to the library) along with 4 equal-sized parts (books split among 4 teachers). We label the total, 46, to show how many the rectangle represents in all. We use a letter to show the unknown amount, which represents the number of books each teacher receives. Using the same letter, x , means that the same number is represented four times.

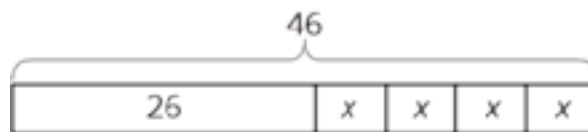

Some situations have parts that are all equal, but each part has been increased from an original amount:

A company manufactures a special type of sensor, and packs them in boxes of 4 for shipment. Then a new design increases the weight of each sensor by 9 grams. The new package of 4 sensors weighs 76 grams. How much did each sensor weigh originally?

We can describe this situation with a rectangle representing a total of 76 split into 4 equal parts. Each part shows that the new weight, $x + 9$, is 9 more than the original weight, x .

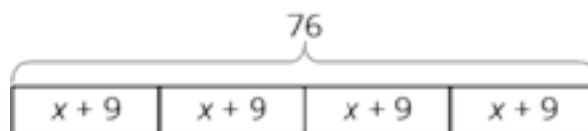

Unit 6 Lesson 2 Cumulative Practice Problems

1. The table shows the number of apples and the total weight of the apples.

number of apples	weight of apples (grams)
2	511
5	1200
8	2016

Estimate the weight of 6 apples.

(From Unit 3, Lesson 1.)

2. Select **all** stories that the tape diagram can represent.

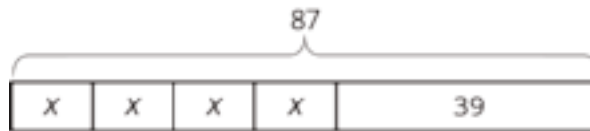

- A. There are 87 children and 39 adults at a show. The seating in the theater is split into 4 equal sections.
- B. There are 87 first graders in after-care. After 39 students are picked up, the teacher put the remaining students into 4 groups for an activity.
- C. Lin buys a pack of 87 pencils. She gives 39 to her teacher and shared the remaining pencils between herself and 3 friends.
- D. Andre buys 4 packs of paper clips with 39 paper clips in each. Then he gives 87 paper clips to his teacher.
- E. Diego's family spends \$87 on 4 tickets to the fair and a \$39 dinner.

3. Andre wants to save \$40 to buy a gift for his dad. Andre's neighbor will pay him weekly to mow the lawn, but Andre always gives a \$2 donation to the food bank in weeks when he earns money. Andre calculates that it will take him 5 weeks to earn the money for his dad's gift. He draws a tape diagram to represent the situation.

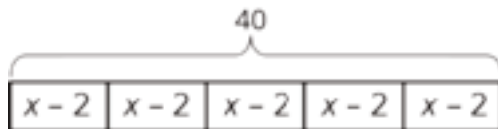

- a. Explain how the parts of the tape diagram represent the story.
- b. How much does Andre's neighbor pay him each week to mow the lawn?
4. Without evaluating each expression, determine which value is the greatest. Explain how you know.

a. $7\frac{5}{6} - 9\frac{3}{4}$

b. $(-7\frac{5}{6}) + (-9\frac{3}{4})$

c. $(-7\frac{5}{6}) \cdot 9\frac{3}{4}$

d. $(-7\frac{5}{6}) \div (-9\frac{3}{4})$

(From Unit 5, Lesson 13.)

5. Solve each equation.

a. $(8.5) \cdot (-3) = a$

b. $(-7) + b = (-11)$

c. $c - (-3) = 15$

d. $d \cdot (-4) = 32$

(From Unit 5, Lesson 15.)

Lesson 3: Reasoning about Equations with Tape Diagrams

Let's see how equations can describe tape diagrams.

3.1: Find Equivalent Expressions

Select **all** the expressions that are **equivalent** to $7(2 - 3n)$. Explain how you know each expression you select is equivalent.

1. $9 - 10n$
2. $14 - 3n$
3. $14 - 21n$
4. $(2 - 3n) \cdot 7$
5. $7 \cdot 2 \cdot (-3n)$

3.2: Matching Equations to Tape Diagrams

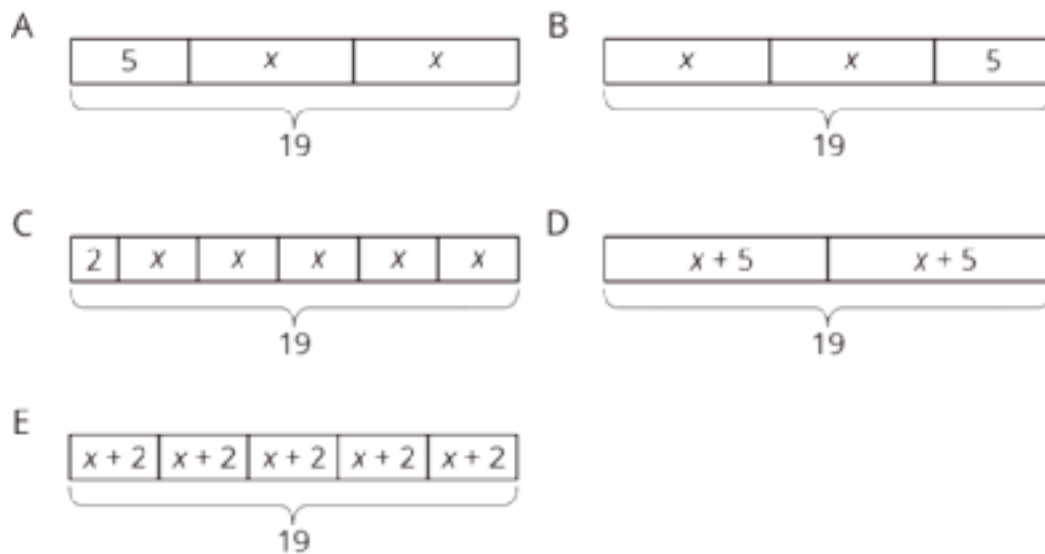

1. Match each equation to one of the tape diagrams. Be prepared to explain how the equation matches the diagram.
 - $2x + 5 = 19$
 - $2 + 5x = 19$
 - $2(x + 5) = 19$
 - $5(x + 2) = 19$
2. Sort the equations into categories of your choosing. Explain the criteria for each category.
 - $19 = 5 + 2x$
 - $(x + 5) \cdot 2 = 19$
 - $19 = (x + 2) \cdot 5$
 - $19 \div 2 = x + 5$
 - $19 - 2 = 5x$

3.3: Drawing Tape Diagrams to Represent Equations

- $114 = 3x + 18$
- $114 = 3(y + 18)$

1. Draw a tape diagram to match each equation.

2. Use any method to find values for x and y that make the equations true.

Are you ready for more?

To make a Koch snowflake:

- Start with an equilateral triangle that has side lengths of 1. This is step 1.
- Replace the middle third of each line segment with a small equilateral triangle with the middle third of the segment forming the base. This is step 2.
- Do the same to each of the line segments. This is step 3.
- Keep repeating this process.



1. What is the perimeter after step 2? Step 3?
2. What happens to the perimeter, or the length of line traced along the outside of the figure, as the process continues?

Lesson 3 Summary

We have seen how tape diagrams represent relationships between quantities. Because of the meaning and properties of addition and multiplication, more than one equation can often be used to represent a single tape diagram.

Let's take a look at two tape diagrams.

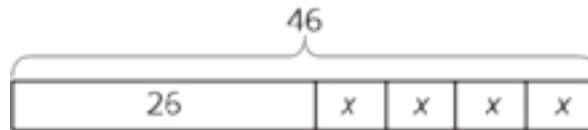

We can describe this diagram with several different equations. Here are some of them:

- $26 + 4x = 46$, because the parts add up to the whole.
- $4x + 26 = 46$, because addition is commutative.
- $46 = 4x + 26$, because if two quantities are equal, it doesn't matter how we arrange them around the equal sign.
- $4x = 46 - 26$, because one part (the part made up of 4 x 's) is the difference between the whole and the other part.

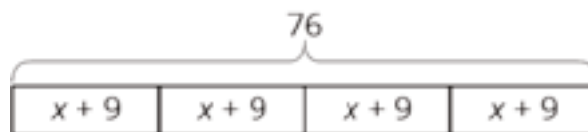

For this diagram:

- $4(x + 9) = 76$, because multiplication means having multiple groups of the same size.
- $(x + 9) \cdot 4 = 76$, because multiplication is commutative.
- $76 \div 4 = x + 9$, because division tells us the size of each equal part.

Unit 6 Lesson 3 Cumulative Practice Problems

1. Solve each equation mentally.

a. $2x = 10$

b. $-3x = 21$

c. $\frac{1}{3}x = 6$

d. $-\frac{1}{2}x = -7$

(From Unit 5, Lesson 15.)

2. Complete the magic squares so that the sum of each row, each column, and each diagonal in a grid are all equal.

0	7	2
	3	

1		
	3	-2
		5

4	2	0
-1		

(From Unit 5, Lesson 3.)

3. Draw a tape diagram to match each equation.

a. $5(x + 1) = 20$

b. $5x + 1 = 20$

4. Select **all** the equations that match the tape diagram.

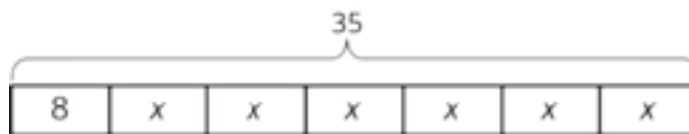

A. $35 = 8 + x + x + x + x + x + x$

B. $35 = 8 + 6x$

C. $6 + 8x = 35$

D. $6x + 8 = 35$

E. $6x + 8x = 35x$

F. $35 - 8 = 6x$

5. Each car is traveling at a constant speed. Find the number of miles each car travels in 1 hour at the given rate.

a. 135 miles in 3 hours

b. 22 miles in $\frac{1}{2}$ hour

c. 7.5 miles in $\frac{1}{4}$ hour

d. $\frac{100}{3}$ miles in $\frac{2}{3}$ hour

e. $97\frac{1}{2}$ miles in $\frac{3}{2}$ hour

(From Unit 4, Lesson 2.)

Lesson 4: Reasoning about Equations and Tape Diagrams (Part 1)

Let's see how tape diagrams can help us answer questions about unknown amounts in stories.

4.1: Algebra Talk: Seeing Structure

Find a solution to each equation without writing anything down.

$$x + 1 = 5$$

$$2(x + 1) = 10$$

$$3(x + 1) = 15$$

$$500 = 100(x + 1)$$

4.2: Situations and Diagrams

Draw a tape diagram to represent each situation. For some of the situations, you need to decide what to represent with a variable.

1. Diego has 7 packs of markers. Each pack has x markers in it. After Lin gives him 9 more markers, he has a total of 30 markers.

2. Elena is cutting a 30-foot piece of ribbon for a craft project. She cuts off 7 feet, and then cuts the remaining piece into 9 equal lengths of x feet each.

3. A construction manager weighs a bundle of 9 identical bricks and a 7-pound concrete block. The bundle weighs 30 pounds.

4. A skating rink charges a group rate of \$9 plus a fee to rent each pair of skates. A family rents 7 pairs of skates and pays a total of \$30.

5. Andre bakes 9 pans of brownies. He donates 7 pans to the school bake sale and keeps the rest to divide equally among his class of 30 students.

4.3: Situations, Diagrams, and Equations

Each situation in the previous activity is represented by one of the equations.

- $7x + 9 = 30$
- $30 = 9x + 7$
- $30x + 7 = 9$

1. Match each situation to an equation.
2. Find the solution to each equation. Use your diagrams to help you reason.
3. What does each solution tell you about its situation?

Are you ready for more?

While in New York City, is it a better deal for a group of friends to take a taxi or the subway to get from the Empire State Building to the Metropolitan Museum of Art? Explain your reasoning.

Lesson 4 Summary

Many situations can be represented by equations. Writing an equation to represent a situation can help us express how quantities in the situation are related to each other, and can help us reason about unknown quantities whose value we want to know. Here are three situations:

1. An architect is drafting plans for a new supermarket. There will be a space 144 inches long for rows of nested shopping carts. The first cart is 34 inches long and each nested cart adds another 10 inches. The architect wants to know how many shopping carts will fit in each row.
2. A bakery buys a large bag of sugar that has 34 cups. They use 10 cups to make some cookies. Then they use the rest of the bag to make 144 giant muffins. Their customers want to know how much sugar is in each muffin.
3. Kiran is trying to save \$144 to buy a new guitar. He has \$34 and is going to save \$10 a week from money he earns mowing lawns. He wants to know how many weeks it will take him to have enough money to buy the guitar.

We see the same three numbers in the situations: 10, 34, and 144. How could we represent each situation with an equation?

In the first situation, there is one shopping cart with length 34 and then an unknown number of carts with length 10. Similarly, Kiran has 34 dollars saved and then will save 10 each week for an unknown number of weeks. Both situations have one part of 34 and then equal parts of size 10 that all add together to 144. Their equation is $34 + 10x = 144$.

Since it takes 11 groups of 10 to get from 34 to 144, the value of x in these two situations is $(144 - 34) \div 10$ or 11. There will be 11 nested shopping carts in each row, and it will take Kiran 11 weeks to raise the money for the guitar.

In the bakery situation, there is one part of 10 and then 144 equal parts of unknown size that all add together to 34. The equation is $10 + 144x = 34$. Since 24 is needed to get from 10 to 34, the value of x is $(34 - 10) \div 144$ or $\frac{1}{6}$. There is $\frac{1}{6}$ cup of sugar in each giant muffin.

Unit 6 Lesson 4 Cumulative Practice Problems

1. Draw a square with side length 7 cm.

- a. Predict the perimeter and the length of the diagonal of the square.
- b. Measure the perimeter and the length of the diagonal of the square.
- c. Describe how close the predictions and measurements are.

(From Unit 3, Lesson 1.)

2. Find the products.

- a. $(100) \cdot (-0.09)$
- b. $(-7) \cdot (-1.1)$
- c. $(-7.3) \cdot (5)$
- d. $(-0.2) \cdot (-0.3)$

(From Unit 5, Lesson 9.)

4. Here is a diagram and its corresponding equation. Find the solution to the equation and explain your reasoning.

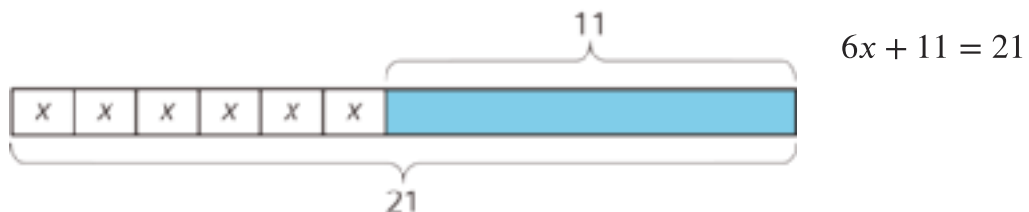

5. a. Plot these points on the coordinate plane:
 $A = (3, 2)$, $B = (7.5, 2)$, $C = (7.5, -2.5)$, $D = (3, -2)$

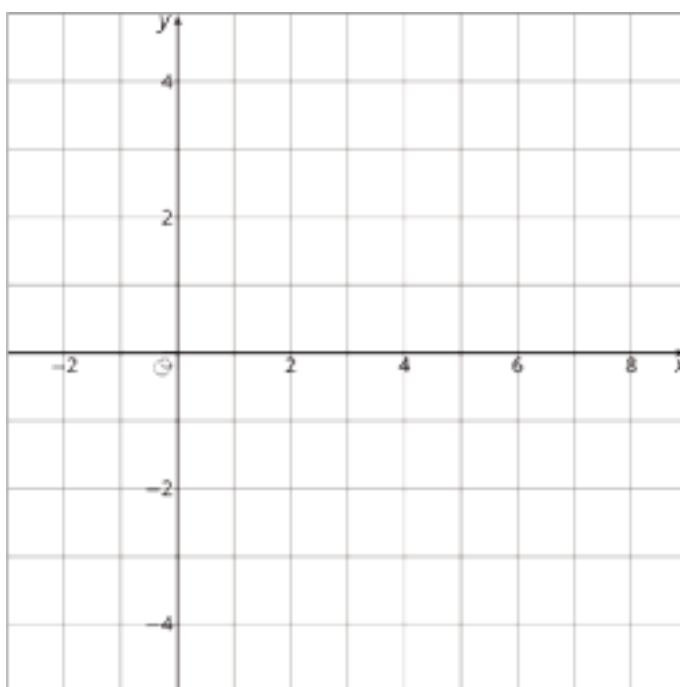

- b. What is the vertical difference between D and A ?
- c. Write an expression that represents the vertical distance between B and C .

(From Unit 5, Lesson 7.)

Lesson 5: Reasoning about Equations and Tape Diagrams (Part 2)

Let's use tape diagrams to help answer questions about situations where the equation has parentheses.

5.1: Algebra Talk: Seeing Structure

Solve each equation mentally.

$$x - 1 = 5$$

$$2(x - 1) = 10$$

$$3(x - 1) = 15$$

$$500 = 100(x - 1)$$

5.2: More Situations and Diagrams

Draw a tape diagram to represent each situation. For some of the situations, you need to decide what to represent with a variable.

1. Each of 5 gift bags contains x pencils. Tyler adds 3 more pencils to each bag. Altogether, the gift bags contain 20 pencils.

2. Noah drew an equilateral triangle with sides of length 5 inches. He wants to increase the length of each side by x inches so the triangle is still equilateral and has a perimeter of 20 inches.

3. An art class charges each student \$3 to attend plus a fee for supplies. Today, \$20 was collected for the 5 students attending the class.

4. Elena ran 20 miles this week, which was three times as far as Clare ran this week. Clare ran 5 more miles this week than she did last week.

5.3: More Situations, Diagrams, and Equations

Each situation in the previous activity is represented by one of the equations.

- $(x + 3) \cdot 5 = 20$

- $3(x + 5) = 20$

1. Match each situation to an equation.
2. Find the solution to each equation. Use your diagrams to help you reason.
3. What does each solution tell you about its situation?

Are you ready for more?

Han, his sister, his dad, and his grandmother step onto a crowded bus with only 3 open seats for a 42-minute ride. They decide Han's grandmother should sit for the entire ride. Han, his sister, and his dad take turns sitting in the remaining two seats, and Han's dad sits 1.5 times as long as both Han and his sister. How many minutes did each one spend sitting?

Lesson 5 Summary

Equations with parentheses can represent a variety of situations.

1. Lin volunteers at a hospital and is preparing toy baskets for children who are patients. She adds 2 items to each basket, after which the supervisor's list shows that 140 toys have been packed into a group of 10 baskets. Lin wants to know how many toys were in each basket before she added the items.
2. A large store has the same number of workers on each of 2 teams to handle different shifts. They decide to add 10 workers to each team, bringing the total number of workers to 140. An executive at the company that runs this chain of stores wants to know how many employees were in each team before the increase.

Each bag in the first story has an unknown number of toys, x , that is increased by 2. Then ten groups of $x + 2$ give a total of 140 toys. An equation representing this situation is $10(x + 2) = 140$. Since 10 times a number is 140, that number is 14, which is the total number of items in each bag. Before Lin added the 2 items there were $14 - 2$ or 12 toys in each bag.

The executive in the second story knows that the size of each team of y employees has been increased by 10. There are now 2 teams of $y + 10$ each. An equation representing this situation is $2(y + 10) = 140$. Since 2 times an amount is 140, that amount is 70, which is the new size of each team. The value of y is $70 - 10$ or 60. There were 60 employees on each team before the increase.

Unit 6 Lesson 5 Cumulative Practice Problems

1. Here are some prices customers paid for different items at a farmer's market. Find the cost for 1 pound of each item.

a. \$5 for 4 pounds of apples

b. \$3.50 for $\frac{1}{2}$ pound of cheese

c. \$8.25 for $1\frac{1}{2}$ pounds of coffee beans

d. \$6.75 for $\frac{3}{4}$ pounds of fudge

e. \$5.50 for a $6\frac{1}{4}$ pound pumpkin

(From Unit 4, Lesson 2.)

2. Find the products.

a. $\frac{2}{3} \cdot \left(\frac{-4}{5}\right)$

b. $\left(\frac{-5}{7}\right) \cdot \left(\frac{7}{5}\right)$

c. $\left(\frac{-2}{39}\right) \cdot 39$

d. $\left(\frac{2}{5}\right) \cdot \left(\frac{-3}{4}\right)$

(From Unit 5, Lesson 9.)

3. Here are two stories:

- A family buys 6 tickets to a show. They also *each* spend \$3 on a snack. They spend \$24 on the show.

- Diego has 24 ounces of juice. He pours equal amounts for each of his 3 friends, and then adds 6 more ounces for each.

Here are two equations:

- $3(x + 6) = 24$
- $6(x + 3) = 24$

- a. Which equation represents which story?
- b. What does x represent in each equation?
- c. Find the solution to each equation. Explain or show your reasoning.
- d. What does each solution tell you about its situation?

4. Here is a diagram and its corresponding equation. Find the solution to the equation and explain your reasoning.

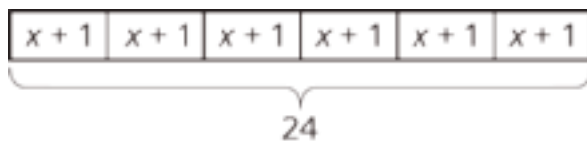

$$6(x + 1) = 24$$

5. Below is a set of data about temperatures. The *range* of a set of data is the distance between the lowest and highest value in the set. What is the range of these temperatures?

9°C , -3°C , 22°C , -5°C , 11°C , 15°C

(From Unit 5, Lesson 7.)

6. A store is having a 25% off sale on all shirts. Show two different ways to calculate the sale price for a shirt that normally costs \$24.

(From Unit 4, Lesson 11.)

Lesson 6: Distinguishing between Two Types of Situations

Let's think about equations with and without parentheses and the kinds of situations they describe.

6.1: Which One Doesn't Belong: Seeing Structure

Which equation doesn't belong?

$$4(x + 3) = 9$$

$$4 + 3x = 9$$

$$4 \cdot x + 12 = 9$$

$$9 = 12 + 4x$$

6.2: Card Sort: Categories of Equations

Your teacher will give you a set of cards that show equations. Sort the cards into 2 categories of your choosing. Be prepared to explain the meaning of your categories. Then, sort the cards into 2 categories in a different way. Be prepared to explain the meaning of your new categories.

6.3: Even More Situations, Diagrams, and Equations

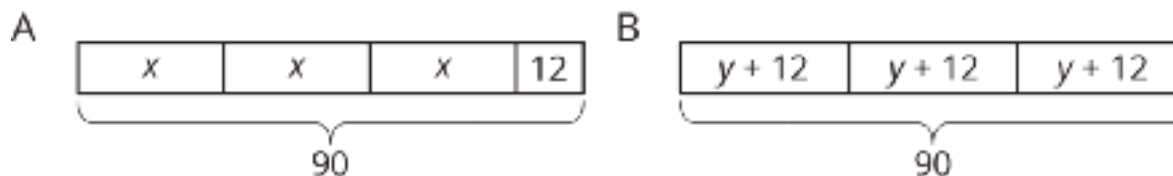

Story 1: Lin had 90 flyers to hang up around the school. She gave 12 flyers to each of three volunteers. Then she took the remaining flyers and divided them up equally between the three volunteers.

Story 2: Lin had 90 flyers to hang up around the school. After giving the same number of flyers to each of three volunteers, she had 12 left to hang up by herself.

1. Which diagram goes with which story? Be prepared to explain your reasoning.
2. In each diagram, what part of the story does the variable represent?

3. Write an equation corresponding to each story. If you get stuck, use the diagram.
4. Find the value of the variable in the story.

Are you ready for more?

A tutor is starting a business. In the first year, they start with 5 clients and charge \$10 per week for an hour of tutoring with each client. For each year following, they double the number of clients and the number of hours each week. Each new client will be charged 150% of the charges of the clients from the previous year.

1. Organize the weekly earnings for each year in a table.
2. Assuming a full-time week is 40 hours per week, how many years will it take to reach full time and how many new clients will be taken on that year?
3. After reaching full time, what is the tutor's annual salary if they take 2 weeks of vacation?
4. Is there another business model you'd recommend for the tutor? Explain your reasoning.

Lesson 6 Summary

In this unit, we encounter two main types of situations that can be represented with an equation. Here is an example of each type:

1. After adding 8 students to each of 6 same-sized teams, there were 72 students altogether.
2. After adding an 8-pound box of tennis rackets to a crate with 6 identical boxes of ping pong paddles, the crate weighed 72 pounds.

The first situation has all equal parts, since additions are made to *each* team. An equation that represents this situation is $6(x + 8) = 72$, where x represents the original number of students on each team. Eight students were added to each group, there are 6 groups, and there are a total of 72 students.

In the second situation, there are 6 equal parts added to one other part. An equation that represents this situation is $6x + 8 = 72$, where x represents the weight of a box of ping pong paddles, there are 6 boxes of ping pong paddles, there is an additional box that weighs 8 pounds, and the crate weighs 72 pounds altogether.

In the first situation, there were 6 equal groups, and 8 students added to each group.
 $6(x + 8) = 72$.

In the second situation, there were 6 equal groups, but 8 more pounds in addition to that.
 $6x + 8 = 72$.

Unit 6 Lesson 6 Cumulative Practice Problems

1. A school ordered 3 large boxes of board markers. After giving 15 markers to each of 3 teachers, there were 90 markers left. The diagram represents the situation. How many markers were originally in each box?

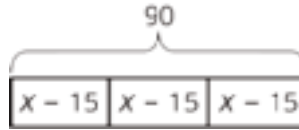

(From Unit 6, Lesson 2.)

2. The diagram can be represented by the equation $25 = 2 + 6x$. Explain where you can see the 6 in the diagram.

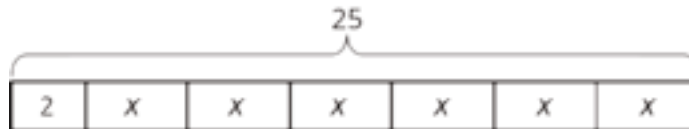

(From Unit 6, Lesson 3.)

3. Match each equation to a story. (Two of the stories match the same equation.)

a. $3(x + 5) = 17$

b. $3x + 5 = 17$

c. $5(x + 3) = 17$

d. $5x + 3 = 17$

a. Jada's teacher fills a travel bag with 5 copies of a textbook. The weight of the bag and books is 17 pounds. The empty travel bag weighs 3 pounds. How much does each book weigh?

b. A piece of scenery for the school play is in the shape of a 5-foot-long rectangle. The designer decides to increase the length. There will be 3 identical rectangles with a total length of 17 feet. By how much did the designer increase the length of each rectangle?

c. Elena spends \$17 and buys a \$3 book and a bookmark for each of her 5 cousins. How much does each bookmark cost?

d. Noah packs up bags at the food pantry to deliver to families. He packs 5 bags that weigh a total of 17 pounds. Each bag contains 3 pounds of groceries and a packet of papers with health-related information. How much does each packet of papers weigh?

e. Andre has 3 times as many pencils as Noah and 5 pens. He has 17 pens and pencils all together. How many pencils does Noah have?

4. Elena walked 20 minutes more than Lin. Jada walked twice as long as Elena. Jada walked for 90 minutes. The equation $2(x + 20) = 90$ describes this situation. Match each expression with the statement in the story with the expression it represents.

A. x

B. $x + 20$

C. $2(x + 20)$

D. 90

1. The number of minutes that Jada walked

2. The number of minutes that Elena walked

3. The number of minutes that Lin walked

Lesson 7: Reasoning about Solving Equations (Part 1)

Let's see how a balanced hanger is like an equation and how moving its weights is like solving the equation.

7.1: Hanger Diagrams

In the two diagrams, all the triangles weigh the same and all the squares weigh the same.

For each diagram, come up with . . .

1. One thing that *must* be true
2. One thing that *could* be true
3. One thing that *cannot possibly* be true

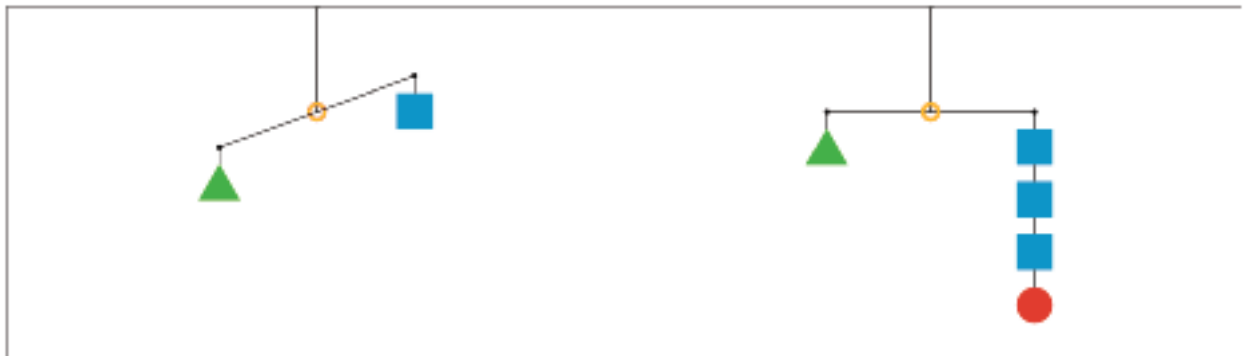

7.2: Hanger and Equation Matching

On each balanced hanger, figures with the same letter have the same weight.

1. Match each hanger to an equation. Complete the equation by writing x , y , z , or w in the empty box.

○ $2\boxed{} + 3 = 5$

○ $3\boxed{} + 2 = 3$

○ $6 = 2\boxed{} + 3$

○ $7 = 3\boxed{} + 1$

2. Find the solution to each equation. Use the hanger to explain what the solution means.

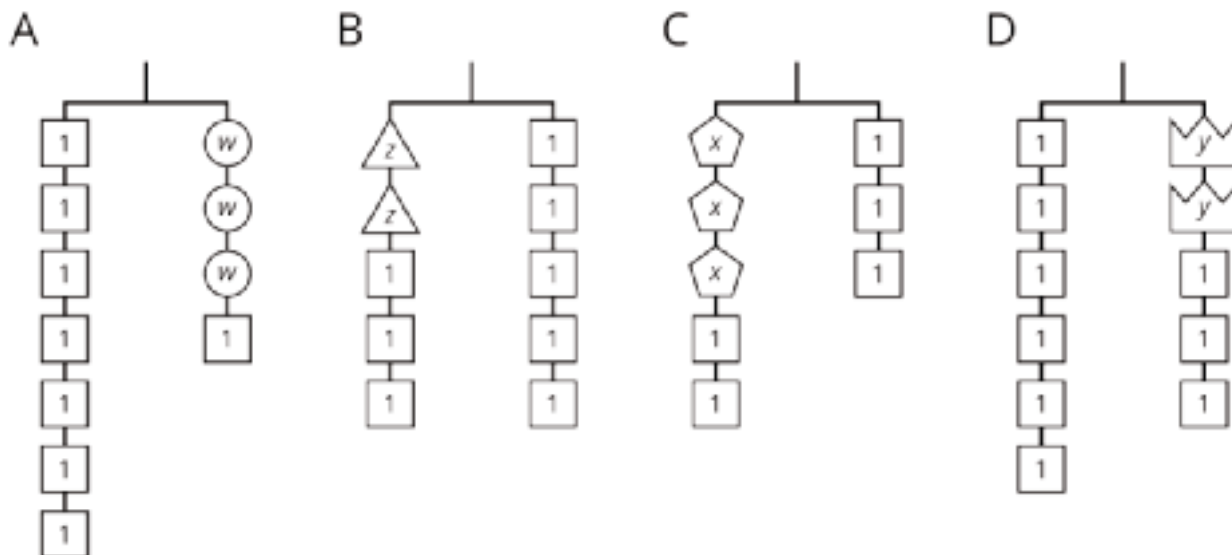

7.3: Use Hangers to Understand Equation Solving

Here are some balanced hangers where each piece is labeled with its weight. For each diagram:

1. Write an equation.
2. Explain how to figure out the weight of a piece labeled with a letter by reasoning about the diagram.
3. Explain how to figure out the weight of a piece labeled with a letter by reasoning about the equation.

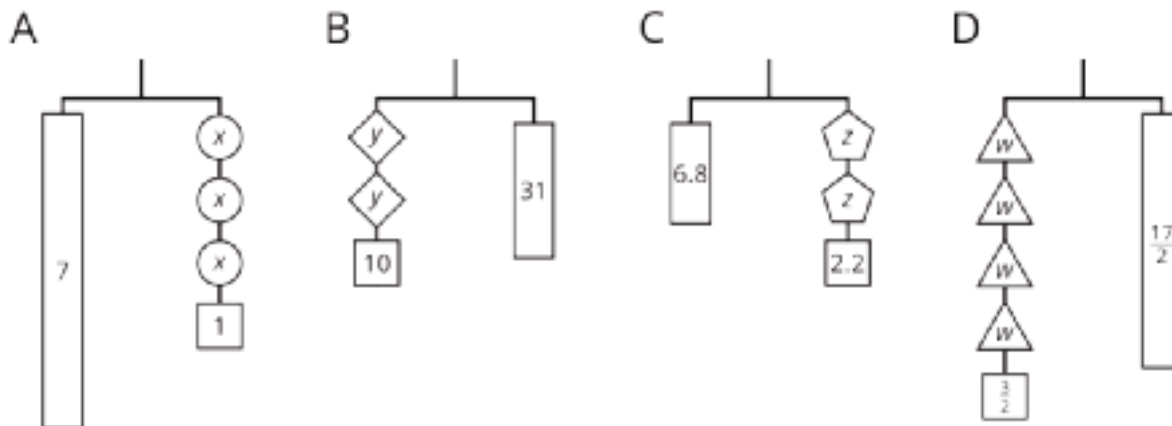

Lesson 7 Summary

In this lesson, we worked with two ways to show that two amounts are equal: a balanced hanger and an equation. We can use a balanced hanger to think about steps to finding an unknown amount in an associated equation.

The hanger shows a total weight of 7 units on one side that is balanced with 3 equal, unknown weights and a 1-unit weight on the other. An equation that represents the relationship is $7 = 3x + 1$.

We can remove a weight of 1 unit from each side and the hanger will stay balanced. This is the same as subtracting 1 from each side of the equation.

An equation for the new balanced hanger is $6 = 3x$.

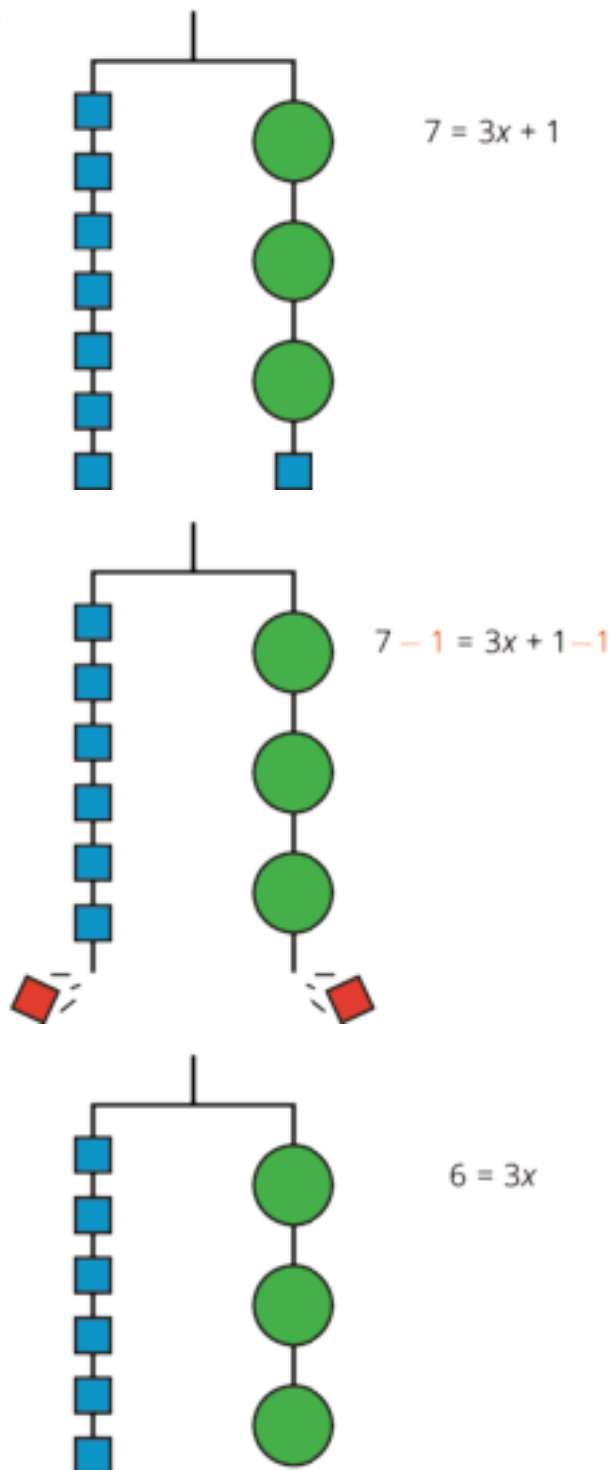

So the hanger will balance with $\frac{1}{3}$ of the weight on each side: $\frac{1}{3} \cdot 6 = \frac{1}{3} \cdot 3x$.

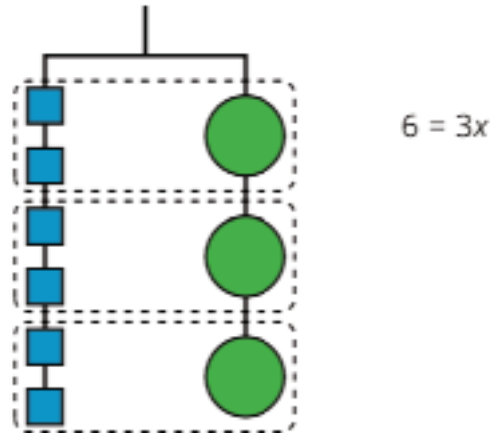

The two sides of the hanger balance with these weights: 6 1-unit weights on one side and 3 weights of unknown size on the other side.

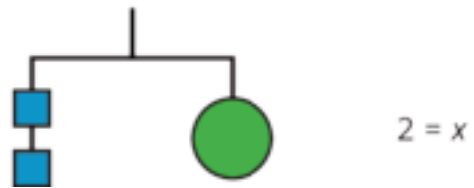

Here is a concise way to write the steps above:

$$7 = 3x + 1$$

$$6 = 3x \quad \text{after subtracting 1 from each side}$$

$$2 = x \quad \text{after multiplying each side by } \frac{1}{3}$$

Unit 6 Lesson 7 Cumulative Practice Problems

1. There is a proportional relationship between the volume of a sample of helium in liters and the mass of that sample in grams. If the mass of a sample is 5 grams, its volume is 28 liters. (5, 28) is shown on the graph below.

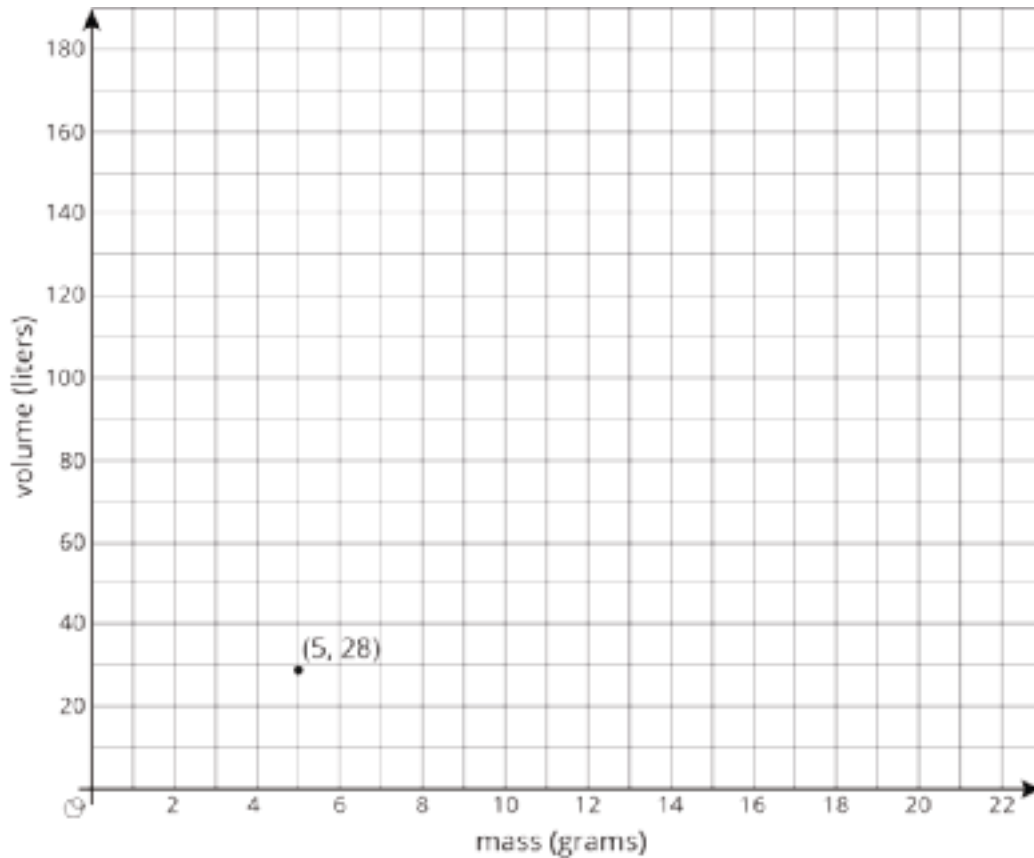

- What is the constant of proportionality in this relationship?
- In this situation, what is the meaning of the number you found in part a?
- Add at least three more points to the graph above, and label with their coordinates.
- Write an equation that shows the relationship between the mass of a sample of helium and its volume. Use m for mass and v for volume.

(From Unit 2, Lesson 11.)

2. Explain how the parts of the balanced hanger compare to the parts of the equation.

$$7 = 2x + 3$$

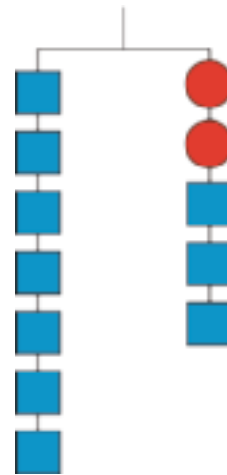

3. For the hanger below:

- Write an equation to represent the hanger.
- Draw more hangers to show each step you would take to find x . Explain your reasoning.
- Write an equation to describe each hanger you drew. Describe how each equation matches its hanger.

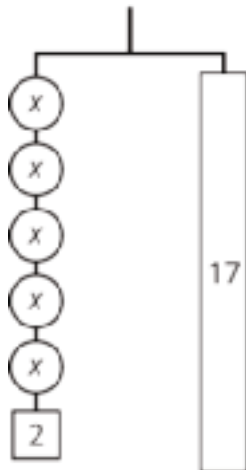

Lesson 8: Reasoning about Solving Equations (Part 2)

Let's use hangers to understand two different ways of solving equations with parentheses.

8.1: Equivalent to $2(x + 3)$

Select **all** the expressions equivalent to $2(x + 3)$.

1. $2 \cdot (x + 3)$
2. $(x + 3)^2$
3. $2 \cdot x + 2 \cdot 3$
4. $2 \cdot x + 3$
5. $(2 \cdot x) + 3$
6. $(2 + x)^3$

8.2: Either Or

1. Explain why either of these equations could represent this hanger:

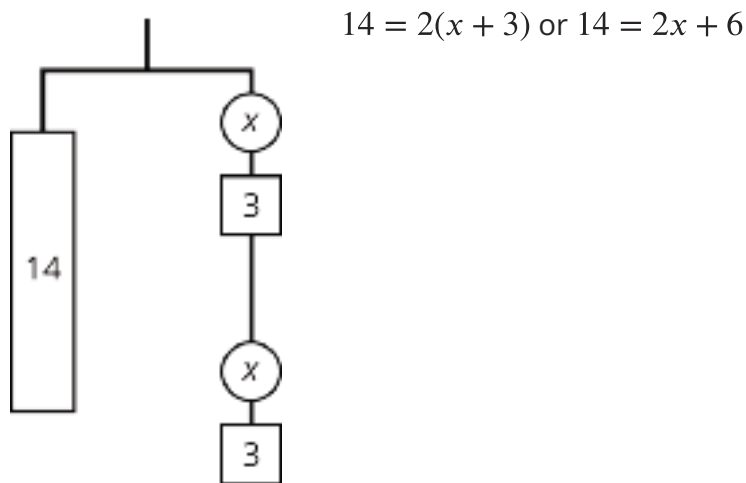

2. Find the weight of one circle. Be prepared to explain your reasoning.

8.3: Use Hangers to Understand Equation Solving, Again

Here are some balanced hangers. Each piece is labeled with its weight.

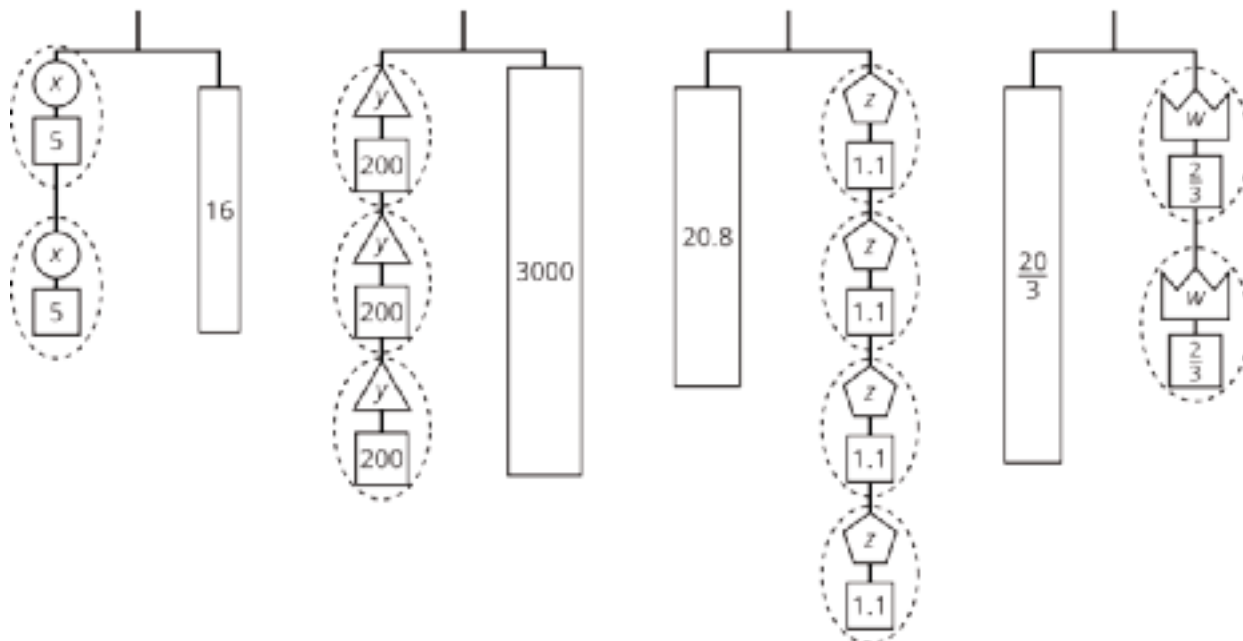

For each diagram:

1. Assign one of these equations to each hanger:

$$2(x + 5) = 16$$

$$3(y + 200) = 3,000$$

$$20.8 = 4(z + 1.1)$$

$$\frac{20}{3} = 2\left(w + \frac{2}{3}\right)$$

2. Explain how to figure out the weight of a piece labeled with a letter by reasoning about the diagram.

3. Explain how to figure out the weight of a piece labeled with a letter by reasoning about the equation.

Lesson 8 Summary

The balanced hanger shows 3 equal, unknown weights and 3 2-unit weights on the left and an 18-unit weight on the right.

There are 3 unknown weights plus 6 units of weight on the left. We could represent this balanced hanger with an equation and solve the equation the same way we did before.

$$3x + 6 = 18$$

$$3x = 12$$

$$x = 4$$

Since there are 3 groups of $x + 2$ on the left, we could represent this hanger with a different equation: $3(x + 2) = 18$.

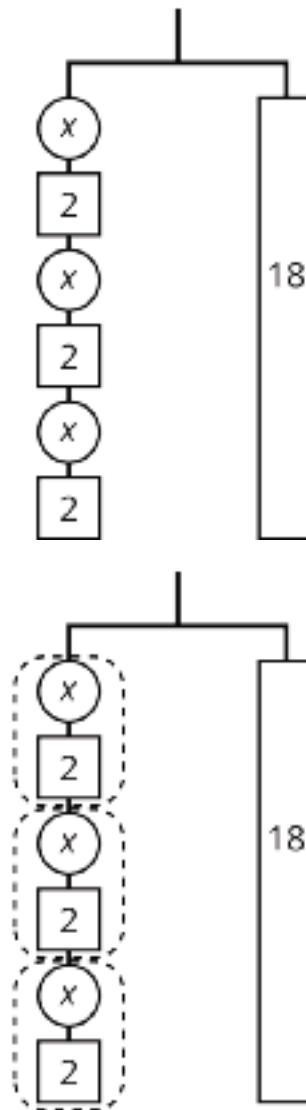

The two sides of the hanger balance with these weights: 3 groups of $x + 2$ on one side, and 18, or 3 groups of 6, on the other side.

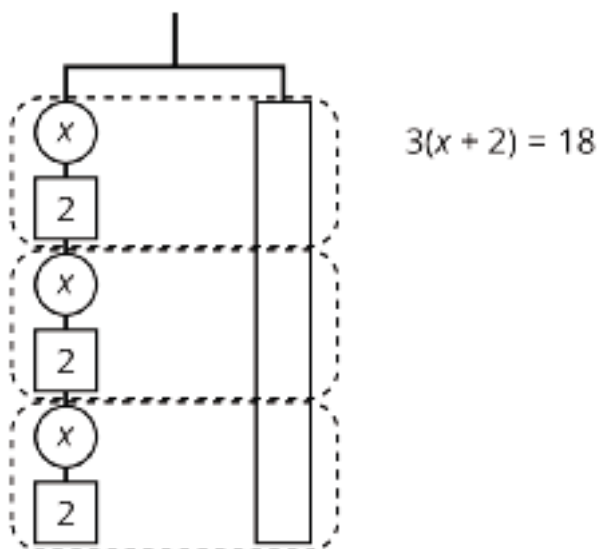

The two sides of the hanger will balance with $\frac{1}{3}$ of the weight on each side:
 $\frac{1}{3} \cdot 3(x + 2) = \frac{1}{3} \cdot 18.$

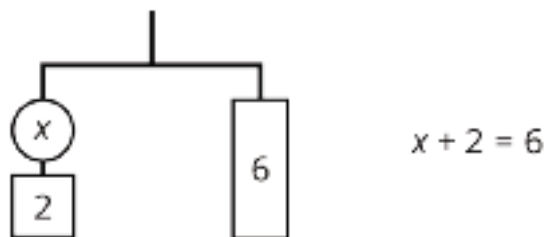

We can remove 2 units of weight from each side, and the hanger will stay balanced. This is the same as subtracting 2 from each side of the equation.

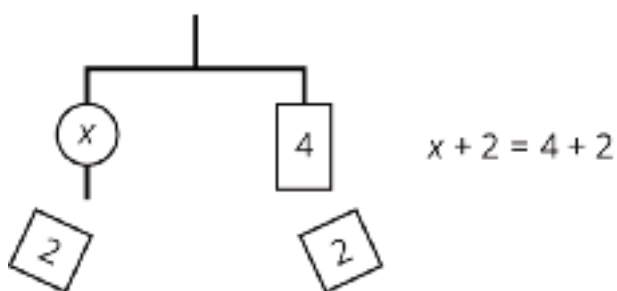

An equation for the new balanced hanger is $x = 4$. This gives the solution to the original equation.

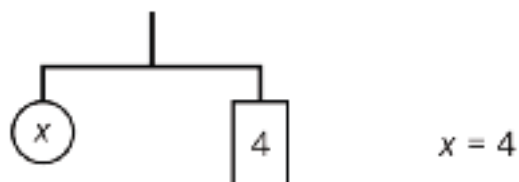

Here is a concise way to write the steps above:

$$\begin{array}{ll}
 3(x + 2) = 18 & \\
 x + 2 = 6 & \text{after multiplying each side by } \frac{1}{3} \\
 x = 4 & \text{after subtracting 2 from each side}
 \end{array}$$

Unit 6 Lesson 8 Cumulative Practice Problems

1. Here is a hanger:

a. Write an equation to represent the hanger.

b. Solve the equation by reasoning about the equation or the hanger. Explain your reasoning.

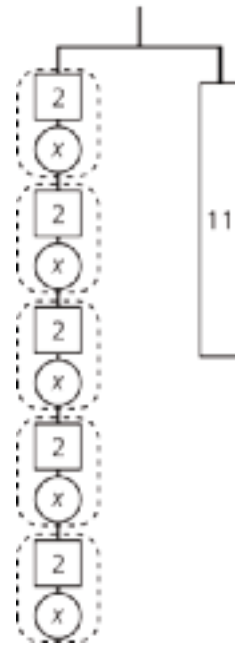

2. Explain how each part of the equation $9 = 3(x + 2)$ is represented in the hanger.

○ x

○ 9

○ 3

○ $x + 2$

○ $3(x + 2)$

○ the equal sign

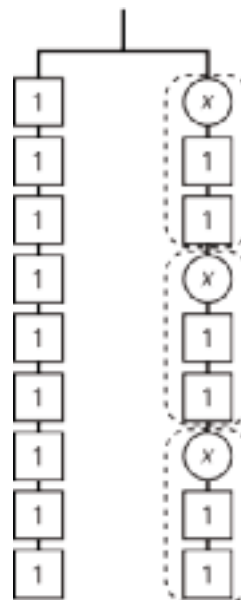

3. Select the word from the following list that best describes each situation.

- | | |
|--|--------------------|
| A. You deposit money in a savings account, and every year the amount of money in the account increases by 2.5%. | 1. Tax |
| B. For every car sold, a car salesman is paid 6% of the car's price. | 2. Commission |
| C. Someone who eats at a restaurant pays an extra 20% of the food price. This extra money is kept by the person who served the food. | 3. Discount |
| D. An antique furniture store pays \$200 for a chair, adds 50% of that amount, and sells the chair for \$300. | 4. Markup |
| E. The normal price of a mattress is \$600, but it is on sale for 10% off. | 5. Tip or gratuity |
| F. For any item you purchase in Texas, you pay an additional 6.25% of the item's price to the state government. | 6. Interest |

(From Unit 4, Lesson 11.)

4. Clare drew this diagram to match the equation $2x + 16 = 50$, but she got the wrong solution as a result of using this diagram.

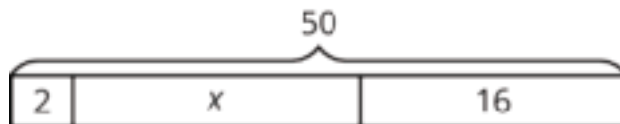

- a. What value for x can be found using the diagram?

- b. Show how to fix Clare's diagram to correctly match the equation.

- c. Use the new diagram to find a correct value for x .

- d. Explain the mistake Clare made when she drew her diagram.

(From Unit 6, Lesson 3.)

Lesson 9: Dealing with Negative Numbers

Let's show that doing the same to each side works for negative numbers too.

9.1: Which One Doesn't Belong: Rational Number Arithmetic

Which equation doesn't belong?

$$15 = -5 \cdot -3$$

$$4 - -2 = 6$$

$$2 + -5 = -3$$

$$-3 \cdot -4 = -12$$

9.2: Old and New Ways to Solve

Solve each equation. Be prepared to explain your reasoning.

1. $x + 6 = 4$

2. $x - -4 = -6$

3. $2(x - 1) = -200$

4. $2x + -3 = -23$

9.3: Keeping It True

Here are some equations that all have the same solution.

$$\begin{aligned}x &= -6 \\x - 3 &= -9 \\-9 &= x - 3 \\900 &= -100(x - 3) \\900 &= (x - 3) \cdot (-100) \\900 &= -100x + 300\end{aligned}$$

1. Explain how you know that each equation has the same solution as the previous equation. Pause for discussion before moving to the next question.

2. Keep your work secret from your partner. Start with the equation $-5 = x$. Do the same thing to each side at least three times to create an equation that has the same solution as the starting equation. Write the equation you ended up with on a slip of paper, and trade equations with your partner.

3. See if you can figure out what steps they used to transform $-5 = x$ into their equation. When you think you know, check with them to see if you are right.

Lesson 9 Summary

When we want to find a solution to an equation, sometimes we just think about what value in place of the variable would make the equation true. Sometimes we perform the same operation on each side (for example, subtract the same amount from each side). The balanced hangers helped us to understand that doing the same thing to each side of an equation keeps the equation true.

Since negative numbers are just numbers, then doing the same thing to each side of an equation works for negative numbers as well. Here are some examples of equations that have negative numbers and steps you could take to solve them.

Example:

$$\begin{aligned} 2(x - 5) &= -6 \\ \frac{1}{2} \cdot 2(x - 5) &= \frac{1}{2} \cdot (-6) && \text{multiply each side by } \frac{1}{2} \\ x - 5 &= -3 \\ x - 5 + 5 &= -3 + 5 && \text{add 5 to each side} \\ x &= 2 \end{aligned}$$

Example:

$$\begin{aligned} -2x + -5 &= 6 \\ -2x + -5 - -5 &= 6 - -5 && \text{subtract -5 from each side} \\ -2x &= 11 \\ -2x \div -2 &= 11 \div -2 && \text{divide each side by -2} \\ x &= -\frac{11}{2} \end{aligned}$$

Doing the same thing to each side maintains equality even if it is not helpful to solving for the unknown amount. For example, we could take the equation $-3x + 7 = -8$ and add -2 to each side:

$$\begin{aligned} -3x + 7 &= -8 \\ -3x + 7 + -2 &= -8 + -2 && \text{add -2 to each side} \\ -3x + 5 &= -10 \end{aligned}$$

If $-3x + 7 = -8$ is true then $-3x + 5 = -10$ is also true, but we are no closer to a solution than we were before adding -2 . We can use moves that maintain equality to make new equations that all have the same solution. Helpful combinations of moves will eventually lead to an equation like $x = 5$, which gives the solution to the original equation (and every equation we wrote in the process of solving).

Unit 6 Lesson 9 Cumulative Practice Problems

1. Solve each equation.

a. $4x = -28$

b. $x - 6 = -2$

c. $-x + 4 = -9$

d. $-3x + 7 = 1$

e. $25x + -11 = -86$

2. Here is an equation $2x + 9 = -15$. Write three different equations that have the same solution as $2x + 9 = -15$. Show or explain how you found them.

3. Select **all** the equations that match the diagram.

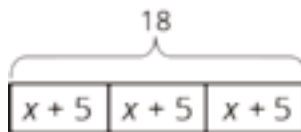

A. $x + 5 = 18$

B. $18 \div 3 = x + 5$

C. $3(x + 5) = 18$

D. $x + 5 = \frac{1}{3} \cdot 18$

E. $3x + 5 = 18$

(From Unit 6, Lesson 3.)

4. There are 88 seats in a theater. The seating in the theater is split into 4 identical sections. Each section has 14 red seats and some blue seats.

a. Draw a tape diagram to represent the situation.

b. What unknown amounts can be found by using the diagram or reasoning about the situation?

(From Unit 6, Lesson 2.)

5. Match each story to an equation.

A. A stack of nested paper cups is 8 inches tall. The first cup is 4 inches tall and each of the rest of the cups in the stack adds $\frac{1}{4}$ inch to the height of the stack.

1. $\frac{1}{4} + 4x = 8$

2. $4 + \frac{1}{4}x = 8$

3. $8x + \frac{1}{4} = 4$

B. A baker uses 4 cups of flour. She uses $\frac{1}{4}$ cup to flour the counters and the rest to make 8 identical muffins.

C. Elena has an 8-foot piece of ribbon. She cuts off a piece that is $\frac{1}{4}$ of a foot long and cuts the remainder into four pieces of equal length.

(From Unit 6, Lesson 4.)

Lesson 10: Different Options for Solving One Equation

Let's think about which way is easier when we solve equations with parentheses.

10.1: Algebra Talk: Solve Each Equation

$$100(x - 3) = 1,000$$

$$500(x - 3) = 5,000$$

$$0.03(x - 3) = 0.3$$

$$0.72(x + 2) = 7.2$$

10.2: Analyzing Solution Methods

Three students each attempted to solve the equation $2(x - 9) = 10$, but got different solutions. Here are their methods. Do you agree with any of their methods, and why?

Noah's method:

$$\begin{aligned}2(x - 9) &= 10 \\2(x - 9) + 9 &= 10 + 9 && \text{add 9 to each side} \\2x &= 19 \\2x \div 2 &= 19 \div 2 && \text{divide each side by 2} \\x &= \frac{19}{2}\end{aligned}$$

Elena's method:

$$\begin{aligned}2(x - 9) &= 10 \\2x - 18 &= 10 && \text{apply the distributive property} \\2x - 18 - 18 &= 10 - 18 && \text{subtract 18 from each side} \\2x &= -8 \\2x \div 2 &= -8 \div 2 && \text{divide each side by 2} \\x &= -4\end{aligned}$$

Andre's method:

$$\begin{aligned}2(x - 9) &= 10 \\2x - 18 &= 10 && \text{apply the distributive property} \\2x - 18 + 18 &= 10 + 18 && \text{add 18 to each side} \\2x &= 28 \\2x \div 2 &= 28 \div 2 && \text{divide each side by 2} \\x &= 14\end{aligned}$$

10.3: Solution Pathways

For each equation, try to solve the equation using each method (dividing each side first, or applying the distributive property first). Some equations are easier to solve by one method than the other. When that is the case, stop doing the harder method and write down the reason you stopped.

1. $2,000(x - 0.03) = 6,000$

2. $2(x + 1.25) = 3.5$

3. $\frac{1}{4}(4 + x) = \frac{4}{3}$

4. $-10(x - 1.7) = -3$

5. $5.4 = 0.3(x + 8)$

Lesson 10 Summary

Equations can be solved in many ways. In this lesson, we focused on equations with a specific structure, and two specific ways to solve them.

Suppose we are trying to solve the equation $\frac{4}{5}(x + 27) = 16$. Two useful approaches are:

- divide each side by $\frac{4}{5}$
- apply the distributive property

In order to decide which approach is better, we can look at the numbers and think about which would be easier to compute. We notice that $\frac{4}{5} \cdot 27$ will be hard, because 27 isn't divisible by 5. But $16 \div \frac{4}{5}$ gives us $16 \cdot \frac{5}{4}$, and 16 is divisible by 4. Dividing each side by $\frac{4}{5}$ gives:

$$\begin{aligned}\frac{4}{5}(x + 27) &= 16 \\ \frac{5}{4} \cdot \frac{4}{5}(x + 27) &= 16 \cdot \frac{5}{4} \\ x + 27 &= 20 \\ x &= -7\end{aligned}$$

Sometimes the calculations are simpler if we first use the distributive property. Let's look at the equation $100(x + 0.06) = 21$. If we first divide each side by 100, we get $\frac{21}{100}$ or 0.21 on the right side of the equation. But if we use the distributive property first, we get an equation that only contains whole numbers.

$$\begin{aligned}100(x + 0.06) &= 21 \\ 100x + 6 &= 21 \\ 100x &= 15 \\ x &= \frac{15}{100}\end{aligned}$$

Unit 6 Lesson 10 Cumulative Practice Problems

1. Andre wants to buy a backpack. The normal price of the backpack is \$40. He notices that a store that sells the backpack is having a 30% off sale. What is the sale price of the backpack?

(From Unit 4, Lesson 11.)

2. On the first math exam, 16 students received an A grade. On the second math exam, 12 students received an A grade. What percentage decrease is that?

(From Unit 4, Lesson 12.)

3. Solve each equation.

a. $2(x - 3) = 14$

b. $-5(x - 1) = 40$

c. $12(x + 10) = 24$

d. $\frac{1}{6}(x + 6) = 11$

e. $\frac{5}{7}(x - 9) = 25$

4. Select **all** expressions that represent a correct solution to the equation $6(x + 4) = 20$.

A. $(20 - 4) \div 6$

B. $\frac{1}{6}(20 - 4)$

C. $20 - 6 - 4$

D. $20 \div 6 - 4$

E. $\frac{1}{6}(20 - 24)$

F. $(20 - 24) \div 6$

5. Lin and Noah are solving the equation $7(x + 2) = 91$.

Lin starts by using the distributive property. Noah starts by dividing each side by 7.

a. Show what Lin's and Noah's full solution methods might look like.

b. What is the same and what is different about their methods?

Lesson 11: Using Equations to Solve Problems

Let's use tape diagrams, equations, and reasoning to solve problems.

11.1: Remember Tape Diagrams

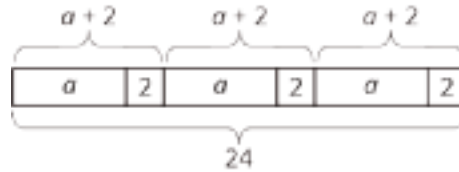

1. Write a story that could be represented by this tape diagram.

2. Write an equation that could be represented by this tape diagram.

11.2: At the Fair

1. Tyler is making invitations to the fair. He has already made some of the invitations, and he wants to finish the rest of them within a week. He is trying to spread out the remaining work, to make the same number of invitations each day. Tyler draws a diagram to represent the situation.



- a. Explain how each part of the situation is represented in Tyler's diagram:

How many total invitations Tyler is trying to make.

How many invitations he has made already.

How many days he has to finish the invitations.

b. How many invitations should Tyler make each day to finish his goal within a week? Explain or show your reasoning.

c. Use Tyler's diagram to write an equation that represents the situation. Explain how each part of the situation is represented in your equation.

d. Show how to solve your equation.

2. Noah and his sister are making prize bags for a game at the fair. Noah is putting 7 pencil erasers in each bag. His sister is putting in some number of stickers. After filling 3 of the bags, they have used a total of 57 items.



a. Explain how the diagram represents the situation.

b. Noah writes the equation $3(x + 7) = 57$ to represent the situation. Do you agree with him? Explain your reasoning.

c. How many stickers is Noah's sister putting in each prize bag? Explain or show your reasoning.

3. A family of 6 is going to the fair. They have a coupon for \$1.50 off each ticket. If they pay \$46.50 for all their tickets, how much does a ticket cost without the coupon? Explain or show your reasoning. If you get stuck, consider drawing a diagram or writing an equation.

11.3: Running Around

Priya, Han, and Elena, are members of the running club at school.

- Priya was busy studying this week and ran 7 fewer miles than last week. She ran 9 times as far as Elena ran this week. Elena only had time to run 4 miles this week.
 - How many miles did Priya run last week?
 - Elena wrote the equation $\frac{1}{9}(x - 7) = 4$ to describe the situation. She solved the equation by multiplying each side by 9 and then adding 7 to each side. How does her solution compare to the way you found Priya's miles?
- One day last week, 6 teachers joined $\frac{5}{7}$ of the members of the running club in an after-school run. Priya counted a total of 31 people running that day. How many members does the running club have?

3. Priya and Han plan a fundraiser for the running club. They begin with a balance of -80 because of expenses. In the first hour of the fundraiser they collect equal donations from 9 family members, which brings their balance to -44. How much did each parent give?
4. The running club uses the money they raised to pay for a trip to a canyon. At one point during a run in the canyon, the students are at an elevation of 128 feet. After descending at a rate of 50 feet per minute, they reach an elevation of -472 feet. How long did the descent take?

Are you ready for more?

A musician performed at three local fairs. At the first he doubled his money and spent \$30. At the second he tripled his money and spent \$54. At the third, he quadrupled his money and spent \$72. In the end he had \$48 left. How much did he have before performing at the fairs?

Lesson 11 Summary

Many problems can be solved by writing and solving an equation. Here is an example:

Clare ran 4 miles on Monday. Then for the next six days, she ran the same distance each day. She ran a total of 22 miles during the week. How many miles did she run on each of the 6 days?

One way to solve the problem is to represent the situation with an equation, $4 + 6x = 22$, where x represents the distance, in miles, she ran on each of the 6 days. Solving the equation gives the solution to this problem.

$$\begin{aligned}4 + 6x &= 22 \\6x &= 18 \\x &= 3\end{aligned}$$

Unit 6 Lesson 11 Cumulative Practice Problems

1. Find the value of each variable.

a. $a \cdot 3 = -30$

b. $-9 \cdot b = 45$

c. $-89 \cdot 12 = c$

d. $d \cdot 88 = -88,000$

(From Unit 5, Lesson 9.)

2. Match each equation to its solution and to the story it describes.

Equations:

a. $5x - 7 = 3$

b. $7 = 3(5 + x)$

c. $3x + 5 = -7$

d. $\frac{1}{3}(x + 7) = 5$

Solutions:

a. -4

b. $\frac{-8}{3}$

c. 2

d. 8

Stories:

- The temperature is -7 . Since midnight the temperature tripled and then rose 5 degrees. What was temperature at midnight?
- Jada has 7 pink roses and some white roses. She gives all of them away: 5 roses to each of her 3 favorite teachers. How many white roses did she give away?
- A musical instrument company reduced the time it takes for a worker to build a guitar. Before the reduction it took 5 hours. Now in 7 hours they can build 3 guitars. By how much did they reduce the time it takes to build each guitar?
- A club puts its members into 5 groups for an activity. After 7 students have to leave early, there are only 3 students left to finish the activity. How many students were in each group?

3. The baby giraffe weighed 132 pounds at birth. He gained weight at a steady rate for the first 7 months until his weight reached 538 pounds. How much did he gain each month?

4. Six teams are out on the field playing soccer. The teams all have the same number of players. The head coach asks for 2 players from each team to come help him move some equipment. Now there are 78 players on the field. Write and solve an equation whose solution is the number of players on each team.

5. A small town had a population of 960 people last year. The population grew to 1200 people this year. By what percentage did the population grow?

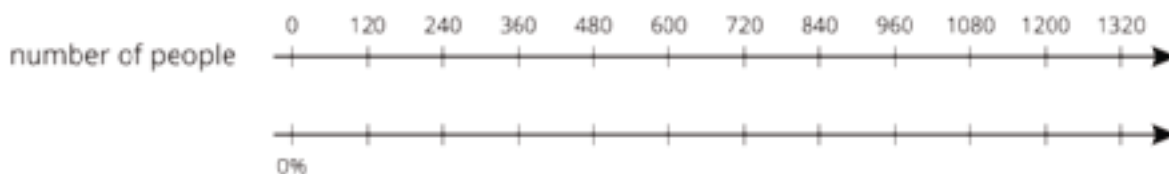

(From Unit 4, Lesson 7.)

6. The gas tank of a truck holds 30 gallons. The gas tank of a passenger car holds 50% less. How many gallons does it hold?

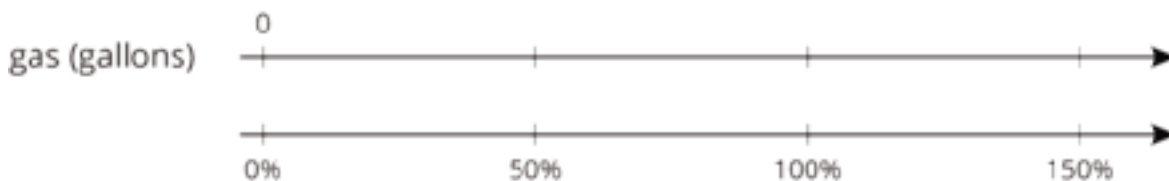

(From Unit 4, Lesson 7.)

Lesson 12: Solving Problems about Percent Increase or Decrease

Let's use tape diagrams, equations, and reasoning to solve problems with negatives and percents.

12.1: 20% Off

An item costs x dollars and then a 20% discount is applied. Select **all** the expressions that could represent the price of the item after the discount.

1. $\frac{20}{100}x$
2. $x - \frac{20}{100}x$
3. $(1 - 0.20)x$
4. $\frac{100-20}{100}x$
5. $0.80x$
6. $(100 - 20)x$

12.2: Walking More Each Day

1. Mai started a new exercise program. On the second day, she walked 5 minutes more than on the first day. On the third day, she increased her walking time from day 2 by 20% and walked for 42 minutes. Mai drew a diagram to show her progress.

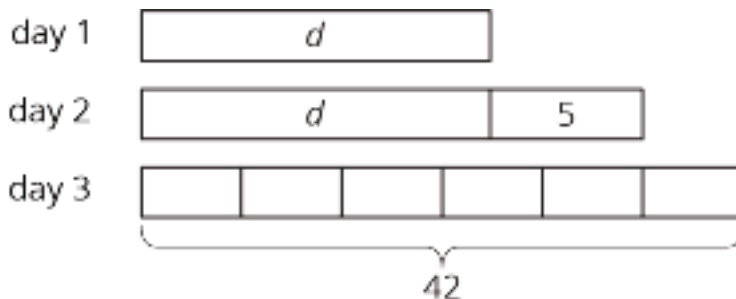

Explain how the diagram represents the situation.

2. Noah said the equation $1.20(d + 5) = 42$ also represents the situation. Do you agree with Noah? Explain your reasoning.

3. Find the number of minutes Mai walked on the first day. Did you use the diagram, the equation, or another strategy? Explain or show your reasoning.

4. Mai has been walking indoors because of cold temperatures. On Day 4 at noon, Mai hears a report that the temperature is only 9 degrees Fahrenheit. She remembers the morning news reporting that the temperature had doubled since midnight and was expected to rise 15 degrees by noon. Mai is pretty sure she can draw a diagram to represent this situation but isn't sure if the equation is $9 = 15 + 2t$ or $2(t + 15) = 9$. What would you tell Mai about the diagram and the equation and how they might be useful to find the temperature, t , at midnight?

12.3: A Sale on Shoes

1. A store is having a sale where all shoes are discounted by 20%. Diego has a coupon for \$3 off of the regular price for one pair of shoes. The store first applies the coupon and then takes 20% off of the reduced price. If Diego pays \$18.40 for a pair of shoes, what was their original price before the sale and without the coupon?
2. Before the sale, the store had 100 pairs of flip flops in stock. After selling some, they notice that $\frac{3}{5}$ of the flip flops they have left are blue. If the store has 39 pairs of blue flip flops, how many pairs of flip flops (any color) have they sold?
3. When the store had sold $\frac{2}{9}$ of the boots that were on display, they brought out another 34 pairs from the stock room. If that gave them 174 pairs of boots out, how many pairs were on display originally?
4. On the morning of the sale, the store donated 50 pairs of shoes to a homeless shelter. Then they sold 64% of their remaining inventory during the sale. If the store had 288 pairs after the donation and the sale, how many pairs of shoes did they have at the start?

Are you ready for more?

A coffee shop offers a special: 33% extra free or 33% off the regular price. Which offer is a better deal? Explain your reasoning.

Lesson 12 Summary

We can solve problems where there is a percent increase or decrease by using what we know about equations. For example, a camping store increases the price of a tent by 25%. A customer then uses a \$10 coupon for the tent and pays \$152.50. We can draw a diagram that shows first the 25% increase and then the \$10 coupon.

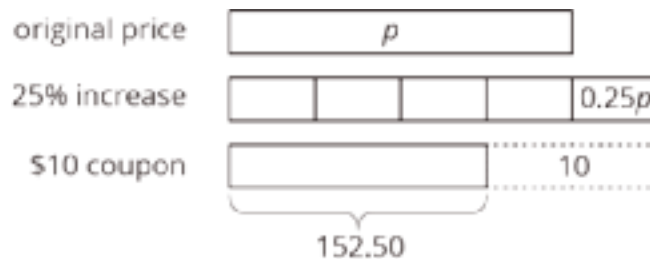

The price after the 25% increase is $p + 0.25p$ or $1.25p$. An equation that represents the situation could be $1.25p - 10 = 152.50$. To find the original price before the increase and discount, we can add 10 to each side and divide each side by 1.25, resulting in $p = 130$. The original price of the tent was \$130.

Unit 6 Lesson 12 Cumulative Practice Problems

1. A backpack normally costs \$25 but it is on sale for \$21. What percentage is the discount?

(From Unit 4, Lesson 12.)

2. Find each product.

a. $\frac{2}{5} \cdot (-10)$

b. $-8 \cdot \left(\frac{-3}{2}\right)$

c. $\frac{10}{6} \cdot 0.6$

d. $\left(\frac{-100}{37}\right) \cdot (-0.37)$

(From Unit 5, Lesson 9.)

3. Select **all** expressions that show x increased by 35%.

A. $1.35x$

B. $\frac{35}{100}x$

C. $x + \frac{35}{100}x$

D. $(1 + 0.35)x$

E. $\frac{100+35}{100}x$

F. $(100 + 35)x$

4. Complete each sentence with the word *discount*, *deposit*, or *withdrawal*.

- a. Clare took \$20 out of her bank account. She made a _____.
- b. Kiran used a coupon when he bought a pair of shoes. He got a _____.
- c. Priya put \$20 into her bank account. She made a _____.
- d. Lin paid less than usual for a pack of gum because it was on sale. She got a _____.

(From Unit 4, Lesson 11.)

5. Here are two stories:

- The initial freshman class at a college is 10% smaller than last year's class. But then during the first week of classes, 20 more students enroll. There are then 830 students in the freshman class.
- A store reduces the price of a computer by \$20. Then during a 10% off sale, a customer pays \$830.

Here are two equations:

- $0.9x + 20 = 830$
- $0.9(x - 20) = 830$

- a. Decide which equation represents each story.
- b. Explain why one equation has parentheses and the other doesn't.
- c. Solve each equation, and explain what the solution means in the situation.

Lesson 13: Reintroducing Inequalities

Let's work with inequalities.

13.1: Greater Than One

The number line shows values of x that make the inequality $x > 1$ true.

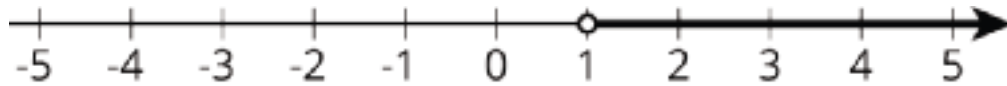

1. Select **all** the values of x from this list that make the inequality $x > 1$ true.

- a. 3
- b. -3
- c. 1
- d. 700
- e. 1.05

2. Name two more values of x that are solutions to the inequality.

13.2: The Roller Coaster

A sign next to a roller coaster at an amusement park says, "You must be at least 60 inches tall to ride." Noah is happy to know that he is tall enough to ride.



1. Noah is x inches tall. Which of the following can be true: $x > 60$, $x = 60$, or $x < 60$? Explain how you know.

2. Noah's friend is 2 inches shorter than Noah. Can you tell if Noah's friend is tall enough to go on the ride? Explain or show your reasoning.

3. List one possible height for Noah that means that his friend is tall enough to go on the ride, and another that means that his friend is too short for the ride.

4. On the number line below, show all the possible heights that Noah's friend could be.

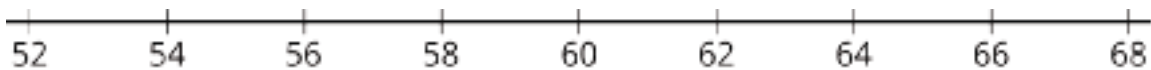

5. Noah's friend is y inches tall. Use y and any of the symbols $<$, $=$, $>$ to express this height.

13.3: Is the Inequality True or False?

The table shows four inequalities and four possible values for x . Decide whether each value makes each inequality true, and complete the table with “true” or “false.” Discuss your thinking with your partner. If you disagree, work to reach an agreement.

x	0	100	-100	25
$x \leq 25$				
$100 < 4x$				
$-3x > -75$				
$10 \geq 35 - x$				

Are you ready for more?

Find an example of an inequality used in the real world and describe it using a number line.

Lesson 13 Summary

We use inequalities to describe a range of numbers. In many places, you are allowed to get a driver’s license when you are at least 16 years old. When checking if someone is old enough to get a license, we want to know if their age is at least 16. If h is the age of a person, then we can check if they are allowed to get a driver’s license by checking if their age makes the inequality $h > 16$ (they are older than 16) or the equation $h = 16$ (they are 16) true. The symbol \geq , pronounced “greater than or equal to,” combines these two cases and we can just check if $h \geq 16$ (their age is greater than or equal to 16). The inequality $h \geq 16$ can be represented on a number line:

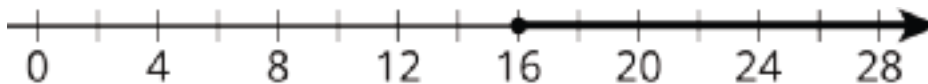

Unit 6 Lesson 13 Cumulative Practice Problems

1. For each inequality, find two values for x that make the inequality true and two values that make it false.

a. $x + 3 > 70$

b. $x + 3 < 70$

c. $-5x < 2$

d. $5x < 2$

2. Here is an inequality: $-3x > 18$.

a. List some values for x that would make this inequality true.

b. How are the solutions to the inequality $-3x \geq 18$ different from the solutions to $-3x > 18$? Explain your reasoning.

3. Here are the prices for cheese pizza at a certain pizzeria:

pizza size	price in dollars
small	11.60
medium	
large	16.25

a. You had a coupon that made the price of a large pizza \$13.00. For what percent off was the coupon?

b. Your friend purchased a medium pizza for \$10.31 with a 30% off coupon. What is the price of a medium pizza without a coupon?

c. Your friend has a 15% off coupon and \$10. What is the largest pizza that your friend can afford, and how much money will be left over after the purchase?

(From Unit 4, Lesson 12.)

4. Select **all** the stories that can be represented by the diagram.



A. Andre studies 7 hours this week for end-of-year exams. He spends 1 hour on English and an equal number of hours each on math, science, and history.

B. Lin spends \$3 on 7 markers and a \$1 pen.

C. Diego spends \$1 on 7 stickers and 3 marbles.

D. Noah shares 7 grapes with 3 friends. He eats 1 and gives each friend the same number of grapes.

E. Elena spends \$7 on 3 notebooks and a \$1 pen.

(From Unit 6, Lesson 4.)

Lesson 14: Finding Solutions to Inequalities in Context

Let's solve more complicated inequalities.

14.1: Solutions to Equations and Solutions to Inequalities

1. Solve $-x = 10$
2. Find 2 solutions to $-x > 10$
3. Solve $2x = -20$
4. Find 2 solutions to $2x > -20$

14.2: Earning Money for Soccer Stuff

1. Andre has a summer job selling magazine subscriptions. He earns \$25 per week plus \$3 for every subscription he sells. Andre hopes to make at least enough money this week to buy a new pair of soccer cleats.
 - a. Let n represent the number of magazine subscriptions Andre sells this week. Write an expression for the amount of money he makes this week.
 - b. The least expensive pair of cleats Andre wants costs \$68. Write and solve an equation to find out how many magazine subscriptions Andre needs to sell to buy the cleats.

- c. If Andre sold 16 magazine subscriptions this week, would he reach his goal? Explain your reasoning.
- d. What are some other numbers of magazine subscriptions Andre could have sold and still reached his goal?
- e. Write an *inequality* expressing that Andre wants to make at least \$68.
- f. Write an inequality to describe the number of subscriptions Andre must sell to reach his goal.
2. Diego has budgeted \$35 from his summer job earnings to buy shorts and socks for soccer. He needs 5 pairs of socks and a pair of shorts. The socks cost different amounts in different stores. The shorts he wants cost \$19.95.
- a. Let x represent the price of one pair of socks. Write an expression for the total cost of the socks and shorts.
- b. Write and solve an equation that says that Diego spent exactly \$35 on the socks and shorts.
- c. List some other possible prices for the socks that would still allow Diego to stay within his budget.
- d. Write an inequality to represent the amount Diego can spend on a single pair of socks.

14.3: Granola Bars and Savings

- Kiran has \$100 saved in a bank account. (The account doesn't earn interest.) He asked Clare to help him figure out how much he could take out each month if he needs to have at least \$25 in the account a year from now.
 - Clare wrote the inequality $-12x + 100 \geq 25$, where x represents the amount Kiran takes out each month. What does $-12x$ represent?
 - Find some values of x that would work for Kiran.
 - We could express *all* the values that would work using either $x \leq \underline{\hspace{1cm}}$ or $x \geq \underline{\hspace{1cm}}$. Which one should we use?
 - Write the answer to Kiran's question using mathematical notation.
- A teacher wants to buy 9 boxes of granola bars for a school trip. Each box usually costs \$7, but many grocery stores are having a sale on granola bars this week. Different stores are selling boxes of granola bars at different discounts.
 - If x represents the dollar amount of the discount, then the amount the teacher will pay can be expressed as $9(7 - x)$. In this expression, what does the quantity $7 - x$ represent?
 - The teacher has \$36 to spend on the granola bars. The equation $9(7 - x) = 36$ represents a situation where she spends all \$36. Solve this equation.
 - What does the solution mean in this situation?

d. The teacher does not have to spend all \$36. Write an inequality relating 36 and $9(7 - x)$ representing this situation.

e. The solution to this inequality must either look like $x \geq 3$ or $x \leq 3$. Which do you think it is? Explain your reasoning.

Are you ready for more?

Jada and Diego baked a large batch of cookies.

- They selected $\frac{1}{4}$ of the cookies to give to their teachers.
- Next, they threw away one burnt cookie.
- They delivered $\frac{2}{5}$ of the remaining cookies to a local nursing home.
- Next, they gave 3 cookies to some neighborhood kids.
- They wrapped up $\frac{2}{3}$ of the remaining cookies to save for their friends.

After all this, they had 15 cookies left. How many cookies did they bake?

Lesson 14 Summary

Suppose Elena has \$5 and sells pens for \$1.50 each. Her goal is to save \$20. We could solve the equation $1.5x + 5 = 20$ to find the number of pens, x , that Elena needs to sell in order to save *exactly* \$20. Adding -5 to both sides of the equation gives us $1.5x = 15$, and then dividing both sides by 1.5 gives the solution $x = 10$ pens.

What if Elena wants to have some money left over? The inequality $1.5x + 5 > 20$ tells us that the amount of money Elena makes needs to be *greater* than \$20. The solution to the previous equation will help us understand what the solutions to the inequality will be. We know that if she sells 10 pens, she will make \$20. Since each pen gives her more money, she needs to sell *more* than 10 pens to make more than \$20. So the **solution to the inequality** is $x > 10$.

Unit 6 Lesson 14 Cumulative Practice Problems

1. The solution to $5 - 3x > 35$ is either $x > -10$ or $-10 > x$. Which solution is correct? Explain how you know.

2. The school band director determined from past experience that if they charge t dollars for a ticket to the concert, they can expect attendance of $1000 - 50t$. The director used this model to figure out that the ticket price needs to be \$8 or greater in order for at least 600 to attend. Do you agree with this claim? Why or why not?

3. Which inequality is true when the value of x is -3 ?

A. $-x - 6 < -3.5$

B. $-x - 6 > 3.5$

C. $-x - 6 > -3.5$

D. $x - 6 > -3.5$

(From Unit 6, Lesson 13.)

4. Draw the solution set for each of the following inequalities.

a. $x \leq 5$

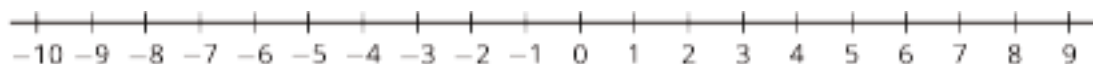

b. $x < \frac{5}{2}$

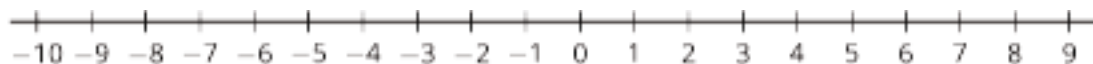

(From Unit 6, Lesson 13.)

5. Write three different equations that match the tape diagram.



(From Unit 6, Lesson 3.)

6. A baker wants to reduce the amount of sugar in his cake recipes. He decides to reduce the amount used in 1 cake by $\frac{1}{2}$ cup. He then uses $4\frac{1}{2}$ cups of sugar to bake 6 cakes.

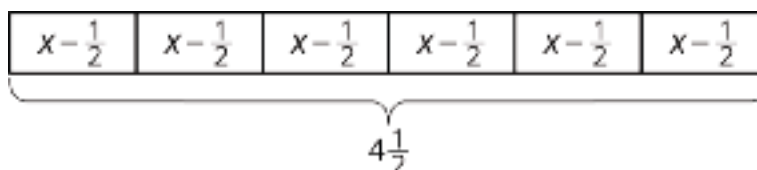

a. Describe how the tape diagram represents the story.

b. How much sugar was originally in each cake recipe?

(From Unit 6, Lesson 2.)

7. One year ago, Clare was 4 feet 6 inches tall. Now Clare is 4 feet 10 inches tall. By what percentage did Clare's height increase in the last year?

(From Unit 4, Lesson 12.)

Lesson 15: Efficiently Solving Inequalities

Let's solve more complicated inequalities.

15.1: Lots of Negatives

Here is an inequality: $-x \geq -4$.

1. Predict what you think the solutions on the number line will look like.
2. Select **all** the values that are solutions to $-x \geq -4$:
 - a. 3
 - b. -3
 - c. 4
 - d. -4
 - e. 4.001
 - f. -4.001
3. Graph the solutions to the inequality on the number line:



15.2: Inequalities with Tables

1. Let's investigate the inequality $x - 3 > -2$.

x	-4	-3	-2	-1	0	1	2	3	4
$x - 3$	-7		-5				-1		1

- a. Complete the table.
- b. For which values of x is it true that $x - 3 = -2$?
- c. For which values of x is it true that $x - 3 > -2$?
- d. Graph the solutions to $x - 3 > -2$ on the number line:



2. Here is an inequality: $2x < 6$.

a. Predict which values of x will make the inequality $2x < 6$ true.

b. Complete the table. Does it match your prediction?

x	-4	-3	-2	-1	0	1	2	3	4
$2x$									

c. Graph the solutions to $2x < 6$ on the number line:



3. Here is an inequality: $-2x < 6$.

a. Predict which values of x will make the inequality $-2x < 6$ true.

b. Complete the table. Does it match your prediction?

x	-4	-3	-2	-1	0	1	2	3	4
$-2x$									

c. Graph the solutions to $-2x < 6$ on the number line:



d. How are the solutions to $2x < 6$ different from the solutions to $-2x < 6$?

15.3: Which Side are the Solutions?

1. Let's investigate $-4x + 5 \geq 25$.

a. Solve $-4x + 5 = 25$.

b. Is $-4x + 5 \geq 25$ true when x is 0? What about when x is 7? What about when x is -7?

c. Graph the solutions to $-4x + 5 \geq 25$ on the number line.



2. Let's investigate $\frac{4}{3}x + 3 < \frac{23}{3}$.

a. Solve $\frac{4}{3}x + 3 = \frac{23}{3}$.

b. Is $\frac{4}{3}x + 3 < \frac{23}{3}$ true when x is 0?

c. Graph the solutions to $\frac{4}{3}x + 3 < \frac{23}{3}$ on the number line.



3. Solve the inequality $3(x + 4) > 17.4$ and graph the solutions on the number line.



4. Solve the inequality $-3\left(x - \frac{4}{3}\right) \leq 6$ and graph the solutions on the number line.



Are you ready for more?

Write at least three different inequalities whose solution is $x > -10$. Find one with x on the left side that uses a $<$.

Lesson 15 Summary

Here is an inequality: $3(10 - 2x) < 18$. The solution to this inequality is all the values you could use in place of x to make the inequality true.

In order to solve this, we can first solve the related equation $3(10 - 2x) = 18$ to get the solution $x = 2$. That means 2 is the boundary between values of x that make the inequality true and values that make the inequality false.

To solve the inequality, we can check numbers greater than 2 and less than 2 and see which ones make the inequality true.

Let's check a number that is greater than 2: $x = 5$. Replacing x with 5 in the inequality, we get $3(10 - 2 \cdot 5) < 18$ or just $0 < 18$. This is true, so $x = 5$ is a solution. This means that all values greater than 2 make the inequality true. We can write the solutions as $x > 2$ and also represent the solutions on a number line:

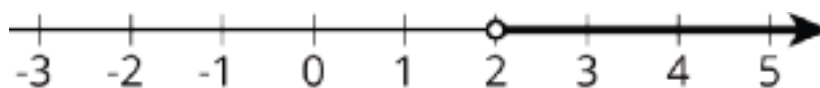

Notice that 2 itself is not a solution because it's the value of x that makes $3(10 - 2x)$ equal to 18, and so it does not make $3(10 - 2x) < 18$ true.

For confirmation that we found the correct solution, we can also test a value that is less than 2. If we test $x = 0$, we get $3(10 - 2 \cdot 0) < 18$ or just $30 < 18$. This is false, so $x = 0$ and all values of x that are less than 2 are not solutions.

Unit 6 Lesson 15 Cumulative Practice Problems

1. a. Consider the inequality $-1 \leq \frac{x}{2}$.
- Predict which values of x will make the inequality true.
 - Complete the table to check your prediction.

x	-4	-3	-2	-1	0	1	2	3	4
$\frac{x}{2}$									

- b. Consider the inequality $1 \leq \frac{-x}{2}$.
- Predict which values of x will make it true.
 - Complete the table to check your prediction.

x	-4	-3	-2	-1	0	1	2	3	4
$\frac{-x}{2}$									

2. Diego is solving the inequality $100 - 3x \geq -50$. He solves the equation $100 - 3x = -50$ and gets $x = 50$. What is the solution to the inequality?
- $x < 50$
 - $x \leq 50$
 - $x > 50$
 - $x \geq 50$
3. Solve the inequality $-5(x - 1) > -40$, and graph the solution on a number line.

4. Select **all** values of x that make the inequality $-x + 6 \geq 10$ true.

- A. -3.9
- B. 4
- C. -4.01
- D. -4
- E. 4.01
- F. 3.9
- G. 0
- H. -7

(From Unit 6, Lesson 13.)

5. Draw the solution set for each of the following inequalities.

a. $x > 7$



b. $x \geq -4.2$

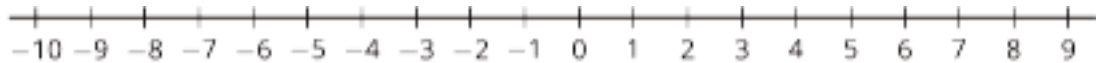

(From Unit 6, Lesson 13.)

6. The price of a pair of earrings is \$22 but Priya buys them on sale for \$13.20.

a. By how much was the price discounted?

b. What was the percentage of the discount?

(From Unit 4, Lesson 12.)

Lesson 16: Interpreting Inequalities

Let's write inequalities.

16.1: Solve Some Inequalities!

For each inequality, find the value or values of x that make it true.

1. $8x + 21 \leq 56$

2. $56 < 7(7 - x)$

16.2: Club Activities Matching

Choose the inequality that best matches each given situation. Explain your reasoning.

1. The Garden Club is planting fruit trees in their school's garden. There is one large tree that needs 5 pounds of fertilizer. The rest are newly planted trees that need $\frac{1}{2}$ pound fertilizer each.

a. $25x + 5 \leq \frac{1}{2}$

b. $\frac{1}{2}x + 5 \leq 25$

c. $\frac{1}{2}x + 25 \leq 5$

d. $5x + \frac{1}{2} \leq 25$

2. The Chemistry Club is experimenting with different mixtures of water with a certain chemical (sodium polyacrylate) to make fake snow.

To make each mixture, the students start with some amount of water, and then add $\frac{1}{7}$ of that amount of the chemical, and then 9 more grams of the chemical. The chemical is expensive, so there can't be more than a certain number of grams of the chemical in any one mixture.

a. $\frac{1}{7}x + 9 \leq 26.25$

b. $9x + \frac{1}{7} \leq 26.25$

c. $26.25x + 9 \leq \frac{1}{7}$

d. $\frac{1}{7}x + 26.25 \leq 9$

3. The Hiking Club is on a hike down a cliff. They begin at an elevation of 12 feet and descend at the rate of 3 feet per minute.

a. $37x - 3 \geq 12$

b. $3x - 37 \geq 12$

c. $12 - 3x \geq -37$

d. $12x - 37 \geq -3$

4. The Science Club is researching boiling points. They learn that at high altitudes, water boils at lower temperatures. At sea level, water boils at 212°F . With each increase of 500 feet in elevation, the boiling point of water is lowered by about 1°F .

a. $212 - \frac{1}{500}e < 195$

b. $\frac{1}{500}e - 195 < 212$

c. $195 - 212e < \frac{1}{500}$

d. $212 - 195e < \frac{1}{500}$

16.3: Club Activities Display

Your teacher will assign your group *one* of the situations from the last task. Create a visual display about your situation. In your display:

- Explain what the variable and each part of the inequality represent
- Write a question that can be answered by the solution to the inequality
- Show how you solved the inequality
- Explain what the solution means in terms of the situation

Are you ready for more?

$\{3, 4, 5, 6\}$ is a set of four consecutive integers whose sum is 18.

1. How many sets of three consecutive integers are there whose sum is between 51 and 60? Can you be sure you've found them all? Explain or show your reasoning.

2. How many sets of four consecutive integers are there whose sum is between 59 and 82? Can you be sure you've found them all? Explain or show your reasoning.

Lesson 16 Summary

We can represent and solve many real-world problems with inequalities. Writing the inequalities is very similar to writing equations to represent a situation. The expressions that make up the inequalities are the same as the ones we have seen in earlier lessons for equations. For inequalities, we also have to think about how expressions compare to each other, which one is bigger, and which one is smaller. Can they also be equal?

For example, a school fundraiser has a minimum target of \$500. Faculty have donated \$100 and there are 12 student clubs that are participating with different activities. How much money should each club raise to meet the fundraising goal? If n is the amount of money that each club raises, then the solution to $100 + 12n = 500$ is the minimum amount each club has to raise to meet the goal. It is more realistic, though, to use the inequality $100 + 12n \geq 500$ since the more money we raise, the more successful the fundraiser will be. There are many solutions because there are many different amounts of money the clubs could raise that would get us above our minimum goal of \$500.

Unit 6 Lesson 16 Cumulative Practice Problems

1. Priya looks at the inequality $12 - x > 5$ and says "I subtract a number from 12 and want a result that is bigger than 5. That means that the solutions should be values of x that are smaller than something."

Do you agree with Priya? Explain your reasoning and include solutions to the inequality in your explanation.

2. When a store had sold $\frac{2}{5}$ of the shirts that were on display, they brought out another 30 from the stockroom. The store likes to keep at least 150 shirts on display. The manager wrote the inequality $\frac{3}{5}x + 30 \geq 150$ to describe the situation.

- a. Explain what $\frac{3}{5}$ means in the inequality.

- b. Solve the inequality.

- c. Explain what the solution means in the situation.

3. You know x is a number less than 4. Select **all** the inequalities that *must* be true.

A. $x < 2$

B. $x + 6 < 10$

C. $5x < 20$

D. $x - 2 > 2$

E. $x < 8$

(From Unit 6, Lesson 13.)

4. Here is an unbalanced hanger.

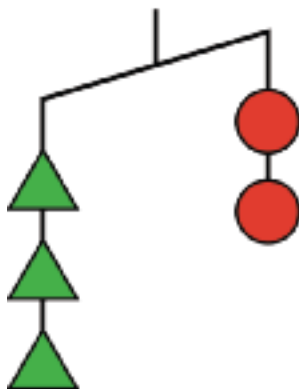

a. If you knew each circle weighed 6 grams, what would that tell you about the weight of each triangle? Explain your reasoning.

b. If you knew each triangle weighed 3 grams, what would that tell you about the weight of each circle? Explain your reasoning.

(From Unit 6, Lesson 13.)

5. Match each sentence with the inequality that could represent the situation.

A. Han got \$2 from Clare, but still has less than \$20.

1. $x - 2 < 20$

2. $2x < 20$

B. Mai spent \$2 and has less than \$20.

3. $x + 2 < 20$

C. If Tyler had twice the amount of money he has, he would have less than \$20.

4. $\frac{1}{2}x < 20$

D. If Priya had half the money she has, she would have less than \$20.

(From Unit 6, Lesson 13.)

Lesson 17: Modeling with Inequalities

Let's look at solutions to inequalities.

17.1: Possible Values

The stage manager of the school musical is trying to figure out how many sandwiches he can order with the \$83 he collected from the cast and crew. Sandwiches cost \$5.99 each, so he lets x represent the number of sandwiches he will order and writes $5.99x \leq 83$. He solves this to 2 decimal places, getting $x \leq 13.86$.

Which of these are valid statements about this situation? (Select **all** that apply.)

1. He can call the sandwich shop and order exactly 13.86 sandwiches.
2. He can round up and order 14 sandwiches.
3. He can order 12 sandwiches.
4. He can order 9.5 sandwiches.
5. He can order 2 sandwiches.
6. He can order -4 sandwiches.

17.2: Elevator

A mover is loading an elevator with many identical 48-pound boxes. The mover weighs 185 pounds. The elevator can carry at most 2000 pounds.

1. Write an inequality that says that the mover will not overload the elevator on a particular ride. Check your inequality with your partner.
2. Solve your inequality and explain what the solution means.
3. Graph the solution to your inequality on a number line.

4. If the mover asked, “How many boxes can I load on this elevator at a time?” what would you tell them?

17.3: Info Gap: Giving Advice

Your teacher will give you either a *problem card* or a *data card*. Do not show or read your card to your partner.

If your teacher gives you the *problem card*:

1. Silently read your card and think about what information you need to be able to answer the question.
2. Ask your partner for the specific information that you need.
3. Explain how you are using the information to solve the problem.

Continue to ask questions until you have enough information to solve the problem.

4. Share the *problem card* and solve the problem independently.
5. Read the *data card* and discuss your reasoning.

If your teacher gives you the *data card*:

1. Silently read your card.
2. Ask your partner “*What specific information do you need?*” and wait for them to *ask* for information.

If your partner asks for information that is not on the card, do not do the calculations for them. Tell them you don’t have that information.

3. Before sharing the information, ask “*Why do you need that information?*”

Listen to your partner’s reasoning and ask clarifying questions.

4. Read the *problem card* and solve the problem independently.
5. Share the *data card* and discuss your reasoning.

Pause here so your teacher can review your work. Ask your teacher for a new set of cards and repeat the activity, trading roles with your partner.

Are you ready for more?

In a day care group, nine babies are five months old and 12 babies are seven months old. How many full months from now will the average age of the 21 babies first surpass 20 months old?

Lesson 17 Summary

We can represent and solve many real-world problems with inequalities. Whenever we write an inequality, it is important to decide what quantity we are representing with a variable. After we make that decision, we can connect the quantities in the situation to write an expression, and finally, the whole inequality.

As we are solving the inequality or equation to answer a question, it is important to keep the meaning of each quantity in mind. This helps us to decide if the final answer makes sense in the context of the situation.

For example: Han has 50 centimeters of wire and wants to make a square picture frame with a loop to hang it that uses 3 centimeters for the loop. This situation can be represented by $3 + 4s = 50$, where s is the length of each side (if we want to use all the wire). We can also use $3 + 4s \leq 50$ if we want to allow for solutions that don't use all the wire. In this case, any positive number that is less or equal to 11.75 cm is a solution to the inequality. Each solution represents a possible side length for the picture frame since Han can bend the wire at any point. In other situations, the variable may represent a quantity that increases by whole numbers, such as with numbers of magazines, loads of laundry, or students. In those cases, only whole-number solutions make sense.

Unit 6 Lesson 17 Cumulative Practice Problems

1. 28 students travel on a field trip. They bring a van that can seat 12 students. Elena and Kiran's teacher asks other adults to drive cars that seat 3 children each to transport the rest of the students.

Elena wonders if she should use the inequality $12 + 3n > 28$ or $12 + 3n \geq 28$ to figure out how many cars are needed. Kiran doesn't think it matters in this case. Do you agree with Kiran? Explain your reasoning.

2. a. In the cafeteria, there is one large 10-seat table and many smaller 4-seat tables. There are enough tables to fit 200 students. Write an inequality whose solution is the possible number of 4-seat tables in the cafeteria.

- b. 5 barrels catch rainwater in the schoolyard. Four barrels are the same size, and the fifth barrel holds 10 liters of water. Combined, the 5 barrels can hold at least 200 liters of water. Write an inequality whose solution is the possible size of each of the 4 barrels.

- c. How are these two problems similar? How are they different?

3. Solve each equation.

a. $5(n - 4) = -60$

b. $-3t + -8 = 25$

c. $7p - 8 = -22$

d. $\frac{2}{5}(j + 40) = -4$

e. $4(w + 1) = -6$

(From Unit 6, Lesson 9.)

4. Select **all** the inequalities that have the same graph as $x < 4$.

A. $x < 2$

B. $x + 6 < 10$

C. $5x < 20$

D. $x - 2 > 2$

E. $x < 8$

(From Unit 6, Lesson 13.)

5. A 200 pound person weighs 33 pounds on the Moon.

a. How much did the person's weight decrease?

b. By what percentage did the person's weight decrease?

(From Unit 4, Lesson 12.)

Lesson 18: Subtraction in Equivalent Expressions

Let's find ways to work with subtraction in expressions.

18.1: Number Talk: Additive Inverses

Find each sum or difference mentally.

$$-30 + -10$$

$$-10 + -30$$

$$-30 - 10$$

$$10 - -30$$

18.2: A Helpful Observation

Lin and Kiran are trying to calculate $7\frac{3}{4} + 3\frac{5}{6} - 1\frac{3}{4}$. Here is their conversation:

Lin: "I plan to first add $7\frac{3}{4}$ and $3\frac{5}{6}$, so I will have to start by finding equivalent fractions with a common denominator."

Kiran: "It would be a lot easier if we could start by working with the $1\frac{3}{4}$ and $7\frac{3}{4}$. Can we rewrite it like $7\frac{3}{4} + 1\frac{3}{4} - 3\frac{5}{6}$?"

Lin: "You can't switch the order of numbers in a subtraction problem like you can with addition; $2 - 3$ is not equal to $3 - 2$."

Kiran: "That's true, but do you remember what we learned about rewriting subtraction expressions using addition? $2 - 3$ is equal to $2 + (-3)$."

1. Write an expression that is equivalent to $7\frac{3}{4} + 3\frac{5}{6} - 1\frac{3}{4}$ that uses addition instead of subtraction.
2. If you wrote the **terms** of your new expression in a different order, would it still be equivalent? Explain your reasoning.

18.3: Organizing Work

1. Write two expressions for the area of the big rectangle.

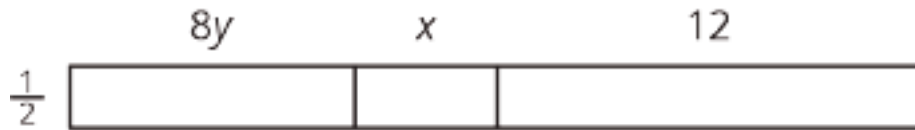

2. Use the distributive property to write an expression that is equivalent to $\frac{1}{2}(8y + -x + -12)$. The boxes can help you organize your work.

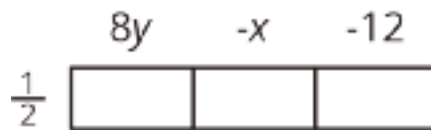

3. Use the distributive property to write an expression that is equivalent to $\frac{1}{2}(8y - x - 12)$.

Are you ready for more?

Here is a calendar for April 2017.

April 2017						
Sunday	Monday	Tuesday	Wednesday	Thursday	Friday	Saturday
						1
2	3	4	5	6	7	8
9	10	11	12	13	14	15
16	17	18	19	20	21	22
23	24	25	26	27	28	29
30						

Let's choose a date: the 10th. Look at the numbers above, below, and to either side of the 10th: 3, 17, 9, 11.

1. Average these four numbers. What do you notice?

2. Choose a different date that is in a location where it has a date above, below, and to either side. Average these four numbers. What do you notice?

3. Explain why the same thing will happen for any date in a location where it has a date above, below, and to either side.

Lesson 18 Summary

Working with subtraction and signed numbers can sometimes get tricky. We can apply what we know about the relationship between addition and subtraction—that subtracting a number gives the same result as adding its opposite—to our work with expressions. Then, we can make use of the properties of addition that allow us to add and group in any order. This can make calculations simpler. For example:

$$\frac{5}{8} - \frac{2}{3} - \frac{1}{8}$$

$$\frac{5}{8} + -\frac{2}{3} + -\frac{1}{8}$$

$$\frac{5}{8} + -\frac{1}{8} + -\frac{2}{3}$$

$$\frac{4}{8} + -\frac{2}{3}$$

We can also organize the work of multiplying signed numbers in expressions. The product $\frac{3}{2}(6y - 2x - 8)$ can be found by drawing a rectangle with the first factor, $\frac{3}{2}$, on one side, and the three terms inside the parentheses on the other side:

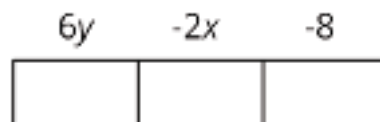

Multiply $\frac{3}{2}$ by each term across the top and perform the multiplications:

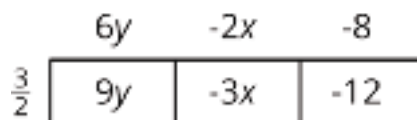
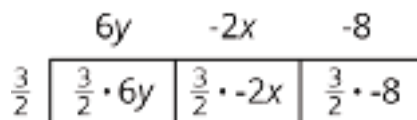

Reassemble the parts to get the expanded version of the original expression:

$$\frac{3}{2}(6y - 2x - 8) = 9y - 3x - 12$$

Unit 6 Lesson 18 Cumulative Practice Problems

1. For each expression, write an equivalent expression that uses only addition.

a. $20 - 9 + 8 - 7$

b. $4x - 7y - 5z + 6$

c. $-3x - 8y - 4 - \frac{8}{7}z$

2. Use the distributive property to write an expression that is equivalent to each expression. If you get stuck, consider drawing boxes to help organize your work.

a. $9(4x - 3y - \frac{2}{3})$

b. $-2(-6x + 3y - 1)$

c. $\frac{1}{5}(20y - 4x - 13)$

d. $8(-x - \frac{1}{2})$

e. $-8(-x - \frac{3}{4}y + \frac{7}{2})$

3. Kiran wrote the expression $x - 10$ for this number puzzle: "Pick a number, add -2, and multiply by 5."

Lin thinks Kiran made a mistake.

a. How can she convince Kiran he made a mistake?

b. What would be a correct expression for this number puzzle?

4. The output from a coal power plant is shown in the table:

energy in megawatts	number of days
1,200	2.4
1,800	3.6
4,000	8
10,000	20

Similarly, the output from a solar power plant is shown in the table:

energy in megawatts	number of days
100	1
650	4
1,200	7
1,750	10

Based on the tables, is the energy output in proportion to the number of days for either plant? If so, write an equation showing the relationship. If not, explain your reasoning.

(From Unit 2, Lesson 7.)

Lesson 19: Expanding and Factoring

Let's use the distributive property to write expressions in different ways.

19.1: Number Talk: Parentheses

Find the value of each expression mentally.

$$2 + 3 \cdot 4$$

$$(2 + 3)(4)$$

$$2 - 3 \cdot 4$$

$$2 - (3 + 4)$$

19.2: Factoring and Expanding with Negative Numbers

In each row, write the equivalent expression. If you get stuck, use a diagram to organize your work. The first row is provided as an example. Diagrams are provided for the first three rows.



factored	expanded
$-3(5 - 2y)$	$-15 + 6y$
$5(a - 6)$	
	$6a - 2b$
$-4(2w - 5z)$	
$-(2x - 3y)$	
	$20x - 10y + 15z$
$k(4 - 17)$	
	$10a - 13a$
$-2x(3y - z)$	
	$ab - bc - 3bd$
$-x(3y - z + 4w)$	

Are you ready for more?

Expand to create an equivalent expression that uses the fewest number of terms: $\left(\left(\left(x + 1\right) \frac{1}{2}\right) + 1\right) \frac{1}{2} + 1$. If we wrote a new expression following the same pattern so that there were 20 sets of parentheses, how could it be expanded into an equivalent expression that uses the fewest number of terms?

Lesson 19 Summary

We can use properties of operations in different ways to rewrite expressions and create equivalent expressions. We have already seen that we can use the distributive property to **expand** an expression, for example $3(x + 5) = 3x + 15$. We can also use the distributive property in the other direction and **factor** an expression, for example $8x + 12 = 4(2x + 3)$.

We can organize the work of using distributive property to rewrite the expression $12x - 8$. In this case we know the product and need to find the factors.

The terms of the product go inside:

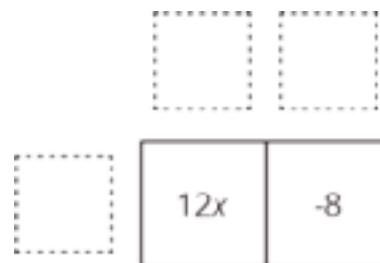

We look at the expressions and think about a factor they have in common. $12x$ and -8 each have a factor of 4. We place the common factor on one side of the large rectangle:

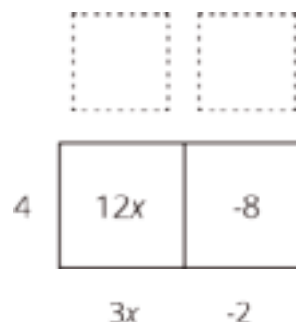

Now we think: "4 times *what* is $12x$?" "4 times *what* is -8 ?" and write the other factors on the other side of the rectangle:



So, $12x - 8$ is equivalent to $4(3x - 2)$.

Unit 6 Lesson 19 Cumulative Practice Problems

1.
 - a. Expand to write an equivalent expression: $\frac{-1}{4}(-8x + 12y)$

 - b. Factor to write an equivalent expression: $36a - 16$

2. Lin missed math class on the day they worked on expanding and factoring. Kiran is helping Lin catch up.
 - a. Lin understands that expanding is using the distributive property, but she doesn't understand what factoring is or why it works. How can Kiran explain factoring to Lin?

 - b. Lin asks Kiran how the diagrams with boxes help with factoring. What should Kiran tell Lin about the boxes?

 - c. Lin asks Kiran to help her factor the expression $-4xy - 12xz + 20xw$. How can Kiran use this example to Lin understand factoring?

3. Complete the equation with numbers that makes the expression on the right side of the equal sign equivalent to the expression on the left side.

$$75a + 25b = \underline{\quad}(\underline{\quad}a + b)$$

4. Elena makes her favorite shade of purple paint by mixing 3 cups of blue paint, $1\frac{1}{2}$ cups of red paint, and $\frac{1}{2}$ of a cup of white paint. Elena has $\frac{2}{3}$ of a cup of white paint.

a. Assuming she has enough red paint and blue paint, how much purple paint can Elena make?

b. How much blue paint and red paint will Elena need to use with the $\frac{2}{3}$ of a cup of white paint?

(From Unit 4, Lesson 3.)

5. Solve each equation.

a. $\frac{-1}{8}d - 4 = \frac{-3}{8}$

b. $\frac{-1}{4}m + 5 = 16$

c. $10b + -45 = -43$

d. $-8(y - 1.25) = 4$

e. $3.2(s + 10) = 32$

(From Unit 6, Lesson 9.)

6. Select **all** the inequalities that have the same solutions as $-4x < 20$.

A. $-x < 5$

B. $4x > -20$

C. $4x < -20$

D. $x < -5$

E. $x > 5$

F. $x > -5$

(From Unit 6, Lesson 13.)

Lesson 20: Combining Like Terms (Part 1)

Let's see how we can tell that expressions are equivalent.

20.1: Why is it True?

Explain why each statement is true.

1. $5 + 2 + 3 = 5 + (2 + 3)$

2. $9a$ is equivalent to $11a - 2a$.

3. $7a + 4 - 2a$ is equivalent to $7a + -2a + 4$.

4. $8a - (8a - 8)$ is equivalent to 8.

20.2: A's and B's

Diego and Jada are both trying to write an expression with fewer terms that is equivalent to

$$7a + 5b - 3a + 4b$$

- Jada thinks $10a + 1b$ is equivalent to the original expression.
- Diego thinks $4a + 9b$ is equivalent to the original expression.

1. We can show expressions are equivalent by writing out all the variables. Explain why the expression on each row (after the first row) is equivalent to the expression on the row before it.

$$7a + 5b - 3a + 4b$$

$$\begin{aligned} & (a + a + a + a + a + a + a) + (b + b + b + b + b) - (a + a + a) + (b + b + b + b) \\ & (a + a + a + a) + (a + a + a) + (b + b + b + b + b) - (a + a + a) + (b + b + b + b) \\ & (a + a + a + a) + (b + b + b + b + b) + (a + a + a) - (a + a + a) + (b + b + b + b) \\ & \quad (a + a + a + a) + (b + b + b + b + b) + (b + b + b + b) \\ & \quad (a + a + a + a) + (b + b + b + b + b + b + b + b + b) \\ & \quad \quad 4a + 9b \end{aligned}$$

2. Here is another way we can rewrite the expressions. Explain why the expression on each row (after the first row) is equivalent to the expression on the row before it.

$$7a + 5b - 3a + 4b$$

$$7a + 5b + (-3a) + 4b$$

$$7a + (-3a) + 5b + 4b$$

$$(7 + -3)a + (5 + 4)b$$

$$4a + 9b$$

Are you ready for more?

Follow the instructions for a number puzzle:

- Take the number formed by the first 3 digits of your phone number and multiply it by 40
- Add 1 to the result
- Multiply by 500
- Add the number formed by the last 4 digits of your phone number, and then add it again
- Subtract 500
- Multiply by $\frac{1}{2}$

1. What is the final number?

2. How does this number puzzle work?

3. Can you invent a new number puzzle that gives a surprising result?

20.3: Making Sides Equal

Replace each ? with an expression that will make the left side of the equation equivalent to the right side.

Set A

1. $6x + ? = 10x$

2. $6x + ? = 2x$

3. $6x + ? = -10x$

4. $6x + ? = 0$

5. $6x + ? = 10$

Check your results with your partner and resolve any disagreements. Next move on to Set B.

Set B

1. $6x - ? = 2x$

2. $6x - ? = 10x$

$$3. 6x - ? = x$$

$$4. 6x - ? = 6$$

$$5. 6x - ? = 4x - 10$$

Lesson 20 Summary

There are many ways to write equivalent expressions that may look very different from each other. We have several tools to find out if two expressions are equivalent.

- Two expressions are definitely not equivalent if they have different values when we substitute the same number for the variable. For example, $2(-3 + x) + 8$ and $2x + 5$ are not equivalent because when x is 1, the first expression equals 4 and the second expression equals 7.
- If two expressions are equal for many different values we substitute for the variable, then the expressions *may* be equivalent, but we don't know for sure. It is impossible to compare the two expressions for all values. To know for sure, we use properties of operations. For example, $2(-3 + x) + 8$ is equivalent to $2x + 2$ because:

$$\begin{aligned} &2(-3 + x) + 8 \\ &\quad -6 + 2x + 8 \quad \text{by the distributive property} \\ &\quad 2x + -6 + 8 \quad \text{by the commutative property} \\ &2x + (-6 + 8) \quad \text{by the associative property} \\ &\quad 2x + 2 \end{aligned}$$

Unit 6 Lesson 20 Cumulative Practice Problems

1. Andre says that $10x + 6$ and $5x + 11$ are equivalent because they both equal 16 when x is 1. Do you agree with Andre? Explain your reasoning.

2. Select **all** expressions that can be subtracted from $9x$ to result in the expression $3x + 5$.
 - A. $-5 + 6x$
 - B. $5 - 6x$
 - C. $6x + 5$
 - D. $6x - 5$
 - E. $-6x + 5$

3. Select **all** the statements that are true for any value of x .
 - A. $7x + (2x + 7) = 9x + 7$
 - B. $7x + (2x - 1) = 9x + 1$
 - C. $\frac{1}{2}x + (3 - \frac{1}{2}x) = 3$
 - D. $5x - (8 - 6x) = -x - 8$
 - E. $0.4x - (0.2x + 8) = 0.2x - 8$
 - F. $6x - (2x - 4) = 4x + 4$

4. For each situation, would you describe it with $x < 25$, $x > 25$, $x \leq 25$, or $x \geq 25$?

a. The library is having a party for any student who read at least 25 books over the summer. Priya read x books and was invited to the party.

b. Kiran read x books over the summer but was not invited to the party.

c.

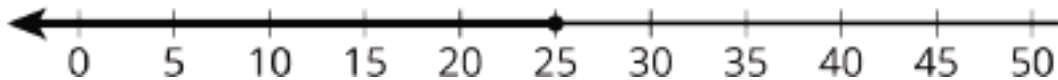

d.

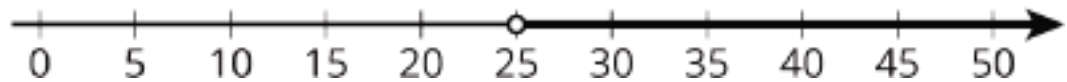

(From Unit 6, Lesson 13.)

5. Consider the problem: A water bucket is being filled with water from a water faucet at a constant rate. When will the bucket be full? What information would you need to be able to solve the problem?

(From Unit 2, Lesson 9.)

Lesson 21: Combining Like Terms (Part 2)

Let's see how to use properties correctly to write equivalent expressions.

21.1: True or False?

Select **all** the statements that are true. Be prepared to explain your reasoning.

1. $4 - 2(3 + 7) = 4 - 2 \cdot 3 - 2 \cdot 7$

2. $4 - 2(3 + 7) = 4 + -2 \cdot 3 + -2 \cdot 7$

3. $4 - 2(3 + 7) = 4 - 2 \cdot 3 + 2 \cdot 7$

4. $4 - 2(3 + 7) = 4 - (2 \cdot 3 + 2 \cdot 7)$

21.2: Seeing it Differently

Some students are trying to write an expression with fewer terms that is equivalent to $8 - 3(4 - 9x)$.

Noah says, "I worked the problem from left to right and ended up with $20 - 45x$."

Lin says, "I started inside the parentheses and ended up with $23x$."

$$8 - 3(4 - 9x)$$

$$8 - 3(4 - 9x)$$

$$5(4 - 9x)$$

$$8 - 3(-5x)$$

$$20 - 45x$$

$$8 + 15x$$

$$23x$$

Jada says, "I used the distributive property and ended up with $27x - 4$."

Andre says, "I also used the distributive property, but I ended up with $-4 - 27x$."

$$8 - 3(4 - 9x)$$

$$8 - 3(4 - 9x)$$

$$8 - (12 - 27x)$$

$$8 - 12 - 27x$$

$$8 - 12 - (-27x)$$

$$-4 - 27x$$

$$27x - 4$$

1. Do you agree with any of them? Explain your reasoning.

2. For each strategy that you disagree with, find and describe the errors.

Are you ready for more?

1. Jada's neighbor said, "My age is the difference between twice my age in 4 years and twice my age 4 years ago." How old is Jada's neighbor?

2. Another neighbor said, "My age is the difference between twice my age in 5 years and twice my age 5 years ago." How old is this neighbor?

3. A third neighbor had the same claim for 17 years from now and 17 years ago, and a fourth for 21 years. Determine those neighbors' ages.

21.3: Grouping Differently

Diego was taking a math quiz. There was a question on the quiz that had the expression $8x - 9 - 12x + 5$. Diego's teacher told the class there was a typo and the expression was supposed to have one set of parentheses in it.

1. Where could you put parentheses in $8x - 9 - 12x + 5$ to make a new expression that is still equivalent to the original expression? How do you know that your new expression is equivalent?

2. Where could you put parentheses in $8x - 9 - 12x + 5$ to make a new expression that is not equivalent to the original expression? List as many different answers as you can.

Lesson 21 Summary

Combining like terms allows us to write expressions more simply with fewer terms. But it can sometimes be tricky with long expressions, parentheses, and negatives. It is helpful to think about some common errors that we can be aware of and try to avoid:

- $6x - x$ is not equivalent to 6. While it might be tempting to think that subtracting x makes the x disappear, the expression is really saying take 1 x away from 6 x 's, and the distributive property tells us that $6x - x$ is equivalent to $(6 - 1)x$.
- $7 - 2x$ is not equivalent to $5x$. The expression $7 - 2x$ tells us to double an unknown amount and subtract it from 7. This is not always the same as taking 5 copies of the unknown.
- $7 - 4(x + 2)$ is not equivalent to $3(x + 2)$. The expression tells us to subtract 4 copies of an amount from 7, not to take $(7 - 4)$ copies of the amount.

If we think about the meaning and properties of operations when we take steps to rewrite expressions, we can be sure we are getting equivalent expressions and are not changing their value in the process.

Unit 6 Lesson 21 Cumulative Practice Problems

- Noah says that $9x - 2x + 4x$ is equivalent to $3x$, because the subtraction sign tells us to subtract everything that comes after $9x$.
 - Elena says that $9x - 2x + 4x$ is equivalent to $11x$, because the subtraction only applies to $2x$.

Do you agree with either of them? Explain your reasoning.

- Identify the error in generating an expression equivalent to $4 + 2x - \frac{1}{2}(10 - 4x)$.
Then correct the error.

$$4 + 2x + \frac{-1}{2}(10 + -4x)$$

$$4 + 2x + -5 + 2x$$

$$4 + 2x - 5 + 2x$$

$$-1$$

- Select **all** expressions that are equivalent to $5x - 15 - 20x + 10$.

A. $5x - (15 + 20x) + 10$

B. $5x + -15 + -20x + 10$

C. $5(x - 3 - 4x + 2)$

D. $-5(-x + 3 + 4x + -2)$

E. $-15x - 5$

F. $-5(3x + 1)$

G. $-15(x - \frac{1}{3})$

4. The school marching band has a budget of up to \$750 to cover 15 new uniforms and competition fees that total \$300. How much can they spend for one uniform?
- Write an inequality to represent this situation.
 - Solve the inequality and describe what it means in the situation.

(From Unit 6, Lesson 14.)

5. Solve the inequality that represents each story. Then interpret what the solution means in the story.
- For every \$9 that Elena earns, she gives x dollars to charity. This happens 7 times this month. Elena wants to be sure she keeps at least \$42 from this month's earnings. $7(9 - x) \geq 42$
 - Lin buys a candle that is 9 inches tall and burns down x inches per minute. She wants to let the candle burn for 7 minutes until it is less than 6 inches tall. $9 - 7x < 6$

(From Unit 6, Lesson 16.)

6. A certain shade of blue paint is made by mixing $1\frac{1}{2}$ quarts of blue paint with 5 quarts of white paint. If you need a total of 16.25 gallons of this shade of blue paint, how much of each color should you mix?

(From Unit 4, Lesson 3.)

Lesson 22: Combining Like Terms (Part 3)

Let's see how we can combine terms in an expression to write it with less terms.

22.1: Are They Equal?

Select **all** expressions that are equal to $8 - 12 - (6 + 4)$.

1. $8 - 6 - 12 + 4$
2. $8 - 12 - 6 - 4$
3. $8 - 12 + (6 + 4)$
4. $8 - 12 - 6 + 4$
5. $8 - 4 - 12 - 6$

22.2: X's and Y's

Match each expression in column A with an equivalent expression from column B. Be prepared to explain your reasoning.

A

1. $(9x + 5y) + (3x + 7y)$
2. $(9x + 5y) - (3x + 7y)$
3. $(9x + 5y) - (3x - 7y)$
4. $9x - 7y + 3x + 5y$
5. $9x - 7y + 3x - 5y$
6. $9x - 7y - 3x - 5y$

B

1. $12(x + y)$
2. $12(x - y)$
3. $6(x - 2y)$
4. $9x + 5y + 3x - 7y$
5. $9x + 5y - 3x + 7y$
6. $9x - 3x + 5y - 7y$

22.3: Seeing Structure and Factoring

Write each expression with fewer terms. Show or explain your reasoning.

1. $3 \cdot 15 + 4 \cdot 15 - 5 \cdot 15$

2. $3x + 4x - 5x$

3. $3(x - 2) + 4(x - 2) - 5(x - 2)$

4. $3\left(\frac{5}{2}x + 6\frac{1}{2}\right) + 4\left(\frac{5}{2}x + 6\frac{1}{2}\right) - 5\left(\frac{5}{2}x + 6\frac{1}{2}\right)$

Lesson 22 Summary

Combining like terms is a useful strategy that we will see again and again in our future work with mathematical expressions. It is helpful to review the things we have learned about this important concept.

- Combining like terms is an application of the distributive property. For example:

$$\begin{aligned}2x + 9x \\(2 + 9) \cdot x \\11x\end{aligned}$$

- It often also involves the commutative and associative properties to change the order or grouping of addition. For example:

$$\begin{aligned}2a + 3b + 4a + 5b \\2a + 4a + 3b + 5b \\(2a + 4a) + (3b + 5b) \\6a + 8b\end{aligned}$$

- We can't change order or grouping when subtracting; so in order to apply the commutative or associative properties to expressions with subtraction, we need to rewrite subtraction as addition. For example:

$$\begin{aligned}2a - 3b - 4a - 5b \\2a + -3b + -4a + -5b \\2a + -4a + -3b + -5b \\-2a + -8b \\-2a - 8b\end{aligned}$$

- Since combining like terms uses properties of operations, it results in expressions that are equivalent.
- The like terms that are combined do not have to be a single number or variable; they may be longer expressions as well. Terms can be combined in any sum where there is a common factor in all the terms. For example, each term in the expression $5(x + 3) - 0.5(x + 3) + 2(x + 3)$ has a factor of $(x + 3)$. We can rewrite the expression with fewer terms by using the distributive property:

$$\begin{aligned}5(x + 3) - 0.5(x + 3) + 2(x + 3) \\(5 - 0.5 + 2)(x + 3) \\6.5(x + 3)\end{aligned}$$

Unit 6 Lesson 22 Cumulative Practice Problems

1. Jada says, "I can tell that $\frac{-2}{3}(x + 5) + 4(x + 5) - \frac{10}{3}(x + 5)$ equals 0 just by looking at it." Is Jada correct? Explain how you know.

2. In each row, decide whether the expression in column A is equivalent to the expression in column B. If they are not equivalent, show how to change one expression to make them equivalent.

A

a. $3x - 2x + 0.5x$

b. $3(x + 4) - 2(x + 4)$

c. $6(x + 4) - 2(x + 5)$

d. $3(x + 4) - 2(x + 4) + 0.5(x + 4)$

e. $20\left(\frac{2}{5}x + \frac{3}{4}y - \frac{1}{2}\right)$

B

a. $1.5x$

b. $x + 3$

c. $2(2x + 7)$

d. 1.5

e. $\frac{1}{2}(16x + 30y - 20)$

3. For each situation, write an expression for the new balance using as few terms as possible.

a. A checking account has a balance of $-\$126.89$. A customer makes two deposits, one $3\frac{1}{2}$ times the other, and then withdraws $\$25$.

b. A checking account has a balance of $\$350$. A customer makes two withdrawals, one $\$50$ more than the other. Then he makes a deposit of $\$75$.

(From Unit 6, Lesson 20.)

4. Tyler is using the distributive property on the expression $9 - 4(5x - 6)$. Here is his work:

$$9 - 4(5x - 6)$$

$$9 + (-4)(5x + -6)$$

$$9 + -20x + -6$$

$$3 - 20x$$

Mai thinks Tyler's answer is incorrect. She says, "If expressions are equivalent then they are equal for any value of the variable. Why don't you try to substitute the same value for x in all the equations and see where they are not equal?"

a. Find the step where Tyler made an error.

b. Explain what he did wrong.

c. Correct Tyler's work.

(From Unit 6, Lesson 21.)

5. a. If $(11 + x)$ is positive, but $(4 + x)$ is negative, what is one number that x could be?
- b. If $(-3 + y)$ is positive, but $(-9 + y)$ is negative, what is one number that y could be?
- c. If $(-5 + z)$ is positive, but $(-6 + z)$ is negative, what is one number that z could be?

(From Unit 6, Lesson 13.)

Lesson 23: Applications of Expressions

- Let's use expressions to solve problems.

23.1: Algebra Talk: Equivalent to $0.75t - 21$

Decide whether each expression is equivalent to $0.75t - 21$. Be prepared to explain how you know.

$$\frac{3}{4}t - 21$$

$$\frac{3}{4}(t - 21)$$

$$0.75(t - 28)$$

$$t - 0.25t - 21$$

23.2: Two Ways to Calculate

Usually when you want to calculate something, there is more than one way to do it. For one or more of these situations, show how the two different ways of calculating are equivalent to each other.

1. Estimating the temperature in Fahrenheit when you know the temperature in Celsius
 - a. Double the temperature in Celsius, then add 30.
 - b. Add 15 to the temperature in Celsius, then double the result.
2. Calculating a 15% tip on a restaurant bill
 - a. Take 10% of the bill amount, take 5% of the bill amount, and add those two values together.
 - b. Multiply the bill amount by 3, divide the result by 2, and then take $\frac{1}{10}$ of that result.

3. Changing a distance in miles to a distance in kilometers
 - a. Take the number of miles, double it, then decrease the result by 20%.
 - b. Divide the number of miles by 5, then multiply the result by 8.

23.3: Which Way?



You have two coupons to the same store: one for 20% off and one for \$30 off. The cashier will let you use them both, and will let you decide in which order to use them.

- Mai says that it doesn't matter in which order you use them. You will get the same discount either way.
- Jada says that you should apply the 20% off coupon first, and then the \$30 off coupon.
- Han says that you should apply the \$30 off coupon first, and then the 20% off coupon.
- Kiran says that it depends on how much you are spending.

Do you agree with any of them? Explain your reasoning.

Credits

CKMath K–8 was originally developed by Open Up Resources and authored by Illustrative Mathematics, <https://www.illustrativemathematics.org>, and is copyrighted as 2017–2019 by Open Up Resources. It is licensed under the Creative Commons Attribution 4.0 International License (CC BY 4.0). The Open Up Resources K–8 Math Curriculum is available at: <https://www.openupresources.org/math-curriculum/>.

Adaptations and updates to the IM K–8 Math English language learner supports are copyright 2019 by Open Up Resources and licensed under the Creative Commons Attribution 4.0 International License (CC BY 4.0),

Adaptations and updates to IM K–8 Math are copyright 2019 by Illustrative Mathematics, including the additional English assessments marked as "B", and the Spanish translation of assessments marked as "B". These adaptations and updates are licensed under the Creative Commons Attribution 4.0 International License (CC BY 4.0).

This particular work is based on additional work of the Core Knowledge® Foundation (www.coreknowledge.org) made available through licensing under a Creative Commons Attribution-NonCommercial-ShareAlike 4.0 International License.

Illustration and Photo Credits

Ivan Pestic / Cover Illustrations

Illustrative Math K–8 / Cover Image, all interior illustrations, diagrams, and pictures / Copyright 2019 / Licensed under the Creative Commons Attribution 4.0 International License (CC BY 4.0).

These materials include public domain images or openly licensed images that are copyrighted by their respective owners, unless otherwise noted/credited. Openly licensed images remain under the terms of their respective licenses.



CKMath™
Core Knowledge **MATHEMATICS™**

CKMath™
Core Knowledge MATHEMATICS™

A comprehensive program for mathematical skills and concepts
as specified in the **Core Knowledge Sequence**
(content and skill guidelines for Grades K–8).

Core Knowledge MATHEMATICS™
units at this level include:

Scale Drawings
Introducing Proportional Relationships
Measuring Circles
Proportional Relationships and Percentages
Rational Number Arithmetic
Expressions, Equations, and Inequalities
Angles, Triangles, and Prisms
Probability and Sampling
Putting It All Together

www.coreknowledge.org

Core Knowledge Curriculum Series™