

Measuring Circles

Teacher Guide

Comparing Areas of Different Shapes

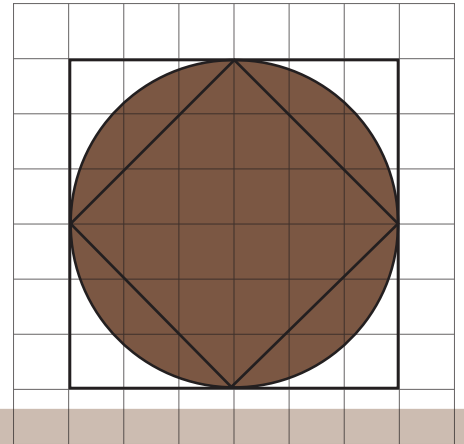

Designing Windows Using Circles

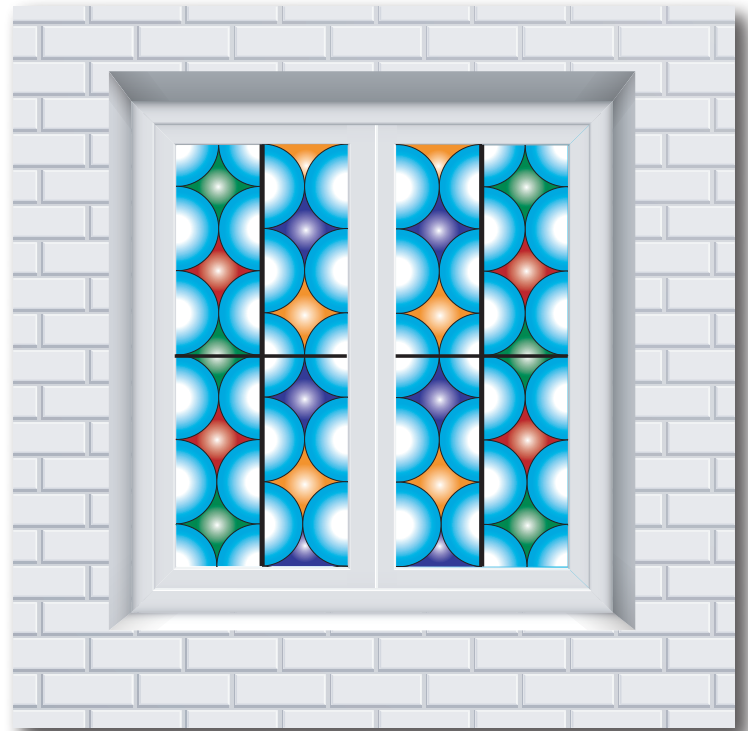

Using a Compass

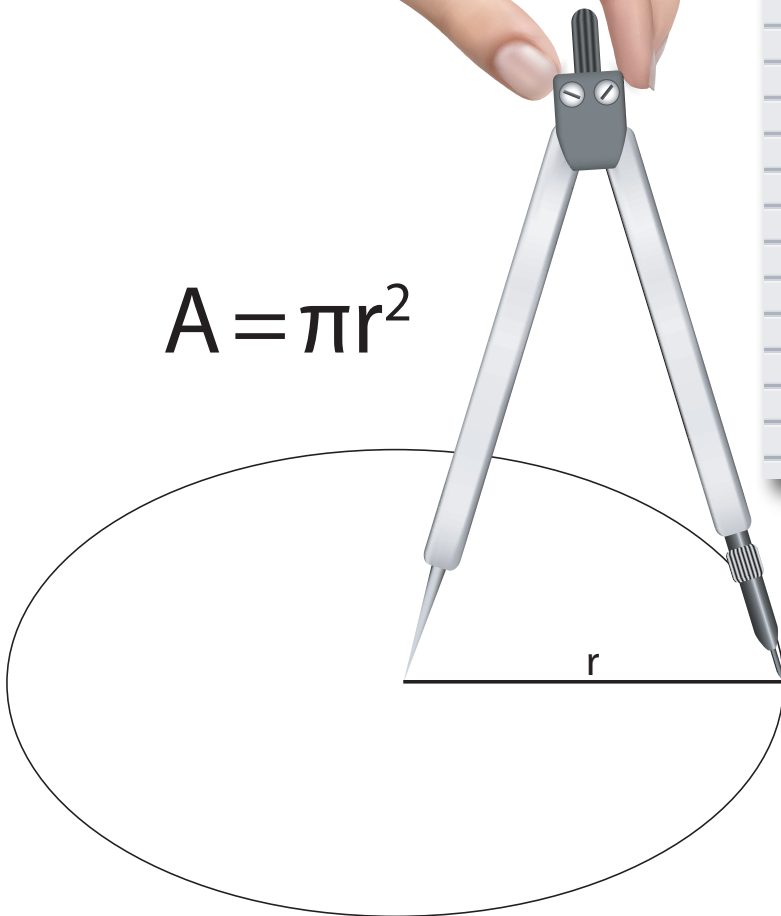

$$A = \pi r^2$$

Calculating Area of Complex Shapes

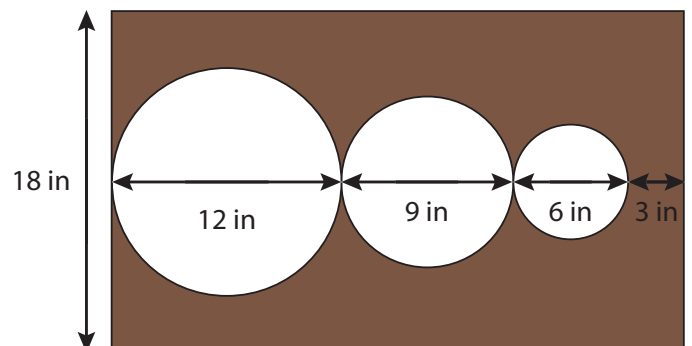

Creative Commons Licensing

This work is licensed under a Creative Commons Attribution-NonCommercial-ShareAlike 4.0 International License.



You are free:

- to Share**—to copy, distribute, and transmit the work
- to Remix**—to adapt the work

Under the following conditions:

Attribution—You must attribute the work in the following manner:
CKMath 6–8 was originally developed by Open Up Resources and authored by Illustrative Mathematics, <https://www.illustrativemathematics.org>, and is copyrighted as 2017–2019 by Open Up Resources. It is licensed under the Creative Commons Attribution 4.0 International License (CC BY 4.0). The Open Up Resources 6–8 Math Curriculum is available at: <https://www.openupresources.org/math-curriculum/>.

Adaptations and updates to the IM 6–8 Math English language learner supports and the additional English assessments marked as "B" are copyright 2019 by Open Up Resources and licensed under the Creative Commons Attribution 4.0 International License (CC BY 4.0).

Adaptations and updates to the IM K–8 Math Spanish translation of assessments marked as "B" are copyright 2019 by Illustrative Mathematics. These adaptations and updates are licensed under the Creative Commons Attribution 4.0 International License (CC BY 4.0).

This particular work is based on additional work of the Core Knowledge® Foundation (www.coreknowledge.org) made available through licensing under a Creative Commons Attribution-Non Commercial-Share Alike 4.0 International License. This does not in any way imply that the Core Knowledge Foundation endorses this work.

Noncommercial—You may not use this work for commercial purposes.

Share Alike—If you alter, transform, or build upon this work, you may distribute the resulting work only under the same or similar license to this one.

With the understanding that:

For any reuse or distribution, you must make clear to others the license terms of this work. The best way to do this is with a link to this web page:

<https://creativecommons.org/licenses/by-nc-sa/4.0/>

Copyright © 2023 Core Knowledge Foundation
www.coreknowledge.org

All Rights Reserved.

Core Knowledge®, Core Knowledge Curriculum Series™, Core Knowledge Math™ and CKMath™ are trademarks of the Core Knowledge Foundation.

Trademarks and trade names are shown in this book strictly for illustrative and educational purposes and are the property of their respective owners. References herein should not be regarded as affecting the validity of said trademarks and trade names.

Measuring Circles

Table of Contents

Introduction: Unit Narrative	1
Student Learning Targets	3
Terminology	5
Required Materials	6
Lesson Plans and Student Task Statements:	
Section 1: Lessons 1–5 Circumference of a Circle	7
Section 2: Lessons 6–10 Area of a Circle	88
Let’s Put It to Work: Lesson 11 Stained-Glass Windows	172
Teacher Resources	182
Family Support Materials	
Unit Assessments	
Assessment Answer Keys	
Cool Downs (Lesson-level Assessments)	
Instructional Masters	

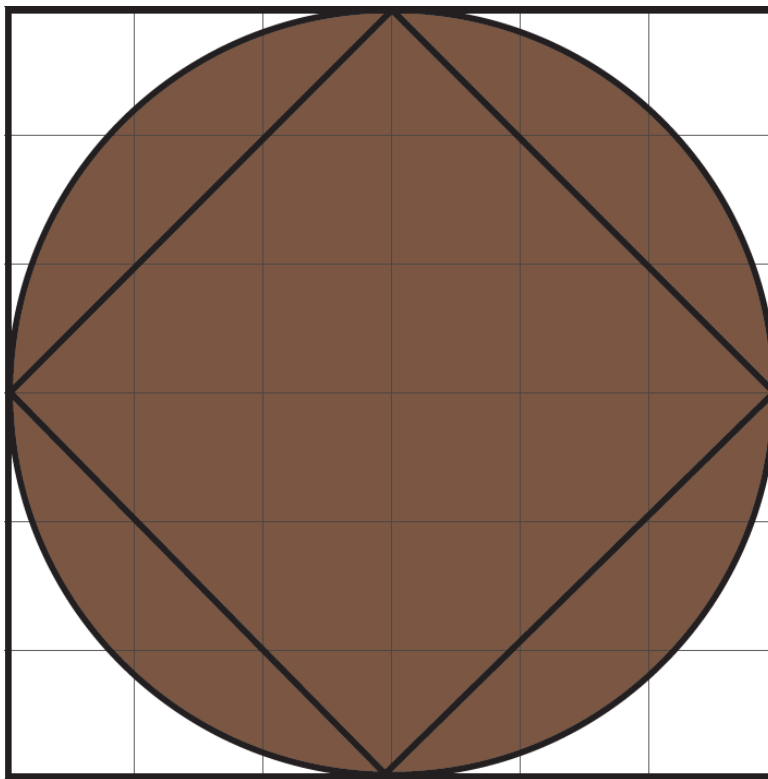

Measuring Circles
Teacher Guide
Core Knowledge Mathematics™

Measuring Circles

Unit Narrative

In this unit, students extend their knowledge of circles and geometric measurement, applying their knowledge of proportional relationships to the study of circles. They extend their grade 6 work with perimeters of polygons to circumferences of circles, and recognize that the circumference of a circle is proportional to its diameter, with constant of proportionality π . They encounter informal derivations of the relationship between area, circumference, and radius.

The unit begins with activities designed to help students come to a more precise understanding of the characteristics of a circle (MP6): a “circle” is the set of points that are equally distant from a point called the “center”; the diameter of a circle is a line segment that passes through its center with endpoints on the circle; the radius is a line segment with one endpoint on the circle and one endpoint at the center. Students identify these characteristics in a variety of contexts (MP2). They use compasses to draw circles with given diameters or radii, and to copy designs that involve circles. Using their newly gained familiarity with circumference and diameter, students measure circular objects, investigating the relationship between measurements of circumference and diameter by making tables and graphs.

The second section involves area. Students encounter two informal derivations of the fact that the area of a circle is equal to π times the square of its radius. The first involves dissecting a disk into sectors and rearranging them to form a shape that approximates a parallelogram of height r and width $2\pi r$. A second argument involves considering a disk as formed of concentric rings, “cutting” the rings with a radius, and “opening” the rings to form a shape that approximates an isosceles triangle of height r and base $2\pi \cdot 2r$.

In the third and last section, students select and use formulas for the area and circumference of a circle to solve abstract and real-world problems that involve calculating lengths and areas. They express measurements in terms of π or using appropriate approximations of π to express them numerically. In grade 8, they will use and extend their knowledge of circles and radii at the beginning of a unit on dilations and similarity.

On using the term circle. Strictly speaking, a circle is one-dimensional—the boundary of a two-dimensional region rather than the region itself. Because students are not yet expected to make this distinction, these materials refer to both circular regions (i.e., disks) and boundaries of disks as “circles,” using illustrations to eliminate ambiguity.

Progression of Disciplinary Language

In this unit, teachers can anticipate students using language for mathematical purposes such as generalizing, justifying, and interpreting. Throughout the unit, students will benefit from routines designed to grow robust disciplinary language, both for their own sense-making and for building

shared understanding with peers. Teachers can formatively assess how students are using language in these ways, particularly when students are using language to:

Generalize

- about categories for sorting circles (Lesson 2)
- about the relationship between circumference and diameter (Lesson 3)
- about circumference and rotation (Lesson 5)
- about the relationship between radius and area of a circle (Lesson 8)

Justify

- reasoning about circumference and perimeter (Lesson 4)
- estimates for the areas of circles (Lesson 7)
- reasoning about areas of curved figures (Lesson 9)
- reasoning about the cost of stained glass windows (Lesson 11)

Interpret

- situations involving circles (Lessons 5 and 8)
- floor plans and maps (Lesson 6)
- situations involving circumference and area (Lesson 10)

In addition, students are expected to critique reasoning about circles and circle measurements, explain reasoning, including about different approximations of pi, and describe features of graphs and of deconstructed circles.

The table shows lessons where new terminology is first introduced, including when students are expected to understand the word or phrase receptively and when students are expected to produce the word or phrase in their own speaking or writing. Terms from the glossary appear bolded. Teachers should continue to support students' use of a new term in the lessons that follow where it was first introduced.

Learning Targets

Measuring Circles

Lesson 1: How Well Can You Measure?

- I can examine quotients and use a graph to decide whether two associated quantities are in a proportional relationship.
- I understand that it can be difficult to measure the quantities in a proportional relationship accurately.

Lesson 2: Exploring Circles

- I can describe the characteristics that make a shape a circle.
- I can identify the diameter, center, radius, and circumference of a circle.

Lesson 3: Exploring Circumference

- I can describe the relationship between circumference and diameter of any circle.
- I can explain what π means.

Lesson 4: Applying Circumference

- I can choose an approximation for π based on the situation or problem.
- If I know the radius, diameter, or circumference of a circle, I can find the other two.

Lesson 5: Circumference and Wheels

- If I know the radius or diameter of a wheel, I can find the distance the wheel travels in some number of revolutions.

Lesson 6: Estimating Areas

- I can calculate the area of a complicated shape by breaking it into shapes whose area I know how to calculate.

Lesson 7: Exploring the Area of a Circle

- If I know a circle's radius or diameter, I can find an approximation for its area.
- I know whether or not the relationship between the diameter and area of a circle is proportional and can explain how I know.

Lesson 8: Relating Area to Circumference

- I can explain how the area of a circle and its circumference are related to each other.
- I know the formula for area of a circle.

Lesson 9: Applying Area of Circles

- I can calculate the area of more complicated shapes that include fractions of circles.
- I can write exact answers in terms of π .

Lesson 10: Distinguishing Circumference and Area

- I can decide whether a situation about a circle has to do with area or circumference.
- I can use formulas for circumference and area of a circle to solve problems.

Lesson 11: Stained-Glass Windows

- I can apply my understanding of area and circumference of circles to solve more complicated problems.

lesson	new terminology	
	receptive	productive
7.3.1	relationship perimeter	
7.3.2	radius diameter circumference center (of a circle)	circle
7.3.3	pi	
7.3.4	half-circle rotation approximation	
7.3.5		diameter circumference pi travel
7.3.6		approximate estimate
7.3.7	area of a circle	
7.3.8	squared formula	radius area of a circle
7.3.10		squared center (of a circle) formula
7.3.11	design	

Required Materials

Blank paper

Compasses

Copies of blackline master

Cylindrical household items

Empty toilet paper roll

Four-function calculators

Geometry toolkits

For grade 6: tracing paper, graph paper, colored pencils, scissors, and an index card to use as a straightedge or to mark right angles.

For grades 7 and 8: everything in grade 6, plus a ruler and protractor. Clear protractors with no holes and with radial lines printed on them are recommended.

Notes: (1) "Tracing paper" is easiest to use when it's a smaller size. Commercially-available "patty

paper" is 5 inches by 5 inches and ideal for this. If using larger sheets of tracing paper, consider cutting them down for student use. (2) When compasses are required in grades 6-8 they are listed as a separate Required Material.

Glue or glue sticks

Markers

Measuring tapes

Pre-printed slips, cut from copies of the blackline master

Receipt tape

Rulers

Rulers marked with centimeters

Scissors

Section: Circumference of a Circle

Lesson 1: How Well Can You Measure?

Goals

- Create and describe (in writing) graphs that show measurements of squares.
- Justify (orally and in writing) whether the relationship shown on a graph is close enough to a straight line through the origin that it might be a proportional relationship with some measurement error.
- Recognize that when we measure the quantities in a proportional relationship, measurement error can cause the graph to be not perfectly straight and the quotients to be not exactly constant.

Learning Targets

- I can examine quotients and use a graph to decide whether two associated quantities are in a proportional relationship.
- I understand that it can be difficult to measure the quantities in a proportional relationship accurately.

Lesson Narrative

The purpose of this lesson is for students to apply what they have learned about proportional relationships to describing geometric figures. The work in this lesson focuses on squares. In the first activity, students see that there is a proportional relationship between the length of the diagonal and the perimeter for squares of different sizes. They use a graph and a table to estimate the constant of proportionality and recognize that measurement error means they can only find an approximate value. This prepares students for future lessons when they will explore the relationship between diameter and circumference of circles.

In the second activity, students see that even taking measurement error into account, the relationship between the length of the diagonal and the area of a square is not a proportional relationship, in preparation for investigating area of circles in future lessons.

Alignments

Building On

- 6.RP.A.3.c: Find a percent of a quantity as a rate per 100 (e.g., 30% of a quantity means $30/100$ times the quantity); solve problems involving finding the whole, given a part and the percent.

Addressing

- 7.RP.A.2.a: Decide whether two quantities are in a proportional relationship, e.g., by testing for equivalent ratios in a table or graphing on a coordinate plane and observing whether the graph is a straight line through the origin.

Building Towards

- 7.G.B.4: Know the formulas for the area and circumference of a circle and use them to solve problems; give an informal derivation of the relationship between the circumference and area of a circle.
- 7.RP.A.3: Use proportional relationships to solve multistep ratio and percent problems. Examples: simple interest, tax, markups and markdowns, gratuities and commissions, fees, percent increase and decrease, percent error.

Instructional Routines

- MLR8: Discussion Supports

Required Materials

Copies of blackline master
Four-function calculators

Rulers marked with centimeters

Required Preparation

Make enough copies of the Perimeter of a Square blackline master for each group of 3 students to get one copy. Prepare to distribute rulers.

Student Learning Goals

Let's see how accurately we can measure.

1.1 Estimating a Percentage

Warm Up: 5 minutes

This warm-up gets students ready to think about making estimates of quotients. Estimation will be central in how students learn about the circumference and area of a circle.

Building On

- 6.RP.A.3.c

Building Towards

- 7.RP.A.3

Launch

Instruct students to find a method of estimation other than performing long division.

Student Task Statement

A student got 16 out of 21 questions correct on a quiz. Use mental estimation to answer these questions.

1. Did the student answer less than or more than 80% of the questions correctly?
2. Did the student answer less than or more than 75% of the questions correctly?

Student Response

1. Less than 80%. Sample reasoning:
 - 16 is 80% of 20, so 16 out of 21 will be less than 80%.
 - 80% of 21 is 80% of 20 and 80% of 1. That makes $16\frac{4}{5}$ so 16 out of 21 is less than 80%.
2. More than 75%. Sample reasoning:
 - 75% is 3 out of 4: $\frac{3}{4}$ of 21 is $\frac{3}{4}$ of 20 and $\frac{3}{4}$ of 1, which is $15\frac{3}{4}$ so 16 out of 21 is more than 75%.
 - 15 is 75% of 20. If you have made 15 free throws out of 20 and then you make one more, your percentage of free throws made should go up. That means that 16 out of 21 is more than 75%.

Activity Synthesis

Ask students to share their strategies for each problem. Record and display their explanations for all to see. Ask students if or how the factors in the problem impacted the strategy choice. To involve more students in the conversation, consider asking:

- “Who can restate ___’s reasoning in a different way?”
- “Did anyone solve the problem the same way but would explain it differently?”
- “Did anyone solve the problem in a different way?”
- “Does anyone want to add on to ___’s strategy?”
- “Do you agree or disagree? Why?”

1.2 Perimeter of a Square

15 minutes (there is a digital version of this activity)

In this activity, students examine the relationship between the length of the diagonal and the perimeter for squares of different sizes. This prepares students for examining the relationship between the diameter and circumference of circles in a future lesson.

Students graph their measurements and find that the points look like they are close to lying on a line through the origin, suggesting that there is a proportional relationship between these

quantities. This makes sense because the squares can all be viewed as scale copies of one square and both the side length and the diagonal should change by the same scale factor.

Because of measurement error, the points do not lie exactly on a line. Whenever analyzing proportional relationships through experimentation, small errors can be expected.

Addressing

- 7.RP.A.2.a

Building Towards

- 7.G.B.4

Launch

Arrange students in groups of 3. Distribute copies of the blackline master and rulers.

Explain that students will only work with 3 of the squares for now and can fill in the other rows of the table at the end of the activity. Assign each group to work with either squares A, B, C, squares D, E, F, or squares G, H, I.

Support for Students with Disabilities

Action and Expression: Develop Expression and Communication. Invite students to talk about what they notice in the graph with their group before writing their ideas down. Display sentence frames to support students when they explain their ideas and ask peers for their ideas. For example, "It looks like....", "I notice that....", and "What do you notice?"

Supports accessibility for: Language; Organization

Student Task Statement

Your teacher will give you a picture of 9 different squares and will assign your group 3 of these squares to examine more closely.

- For each of your assigned squares, measure the length of the diagonal and the perimeter of the square in centimeters.

Check your measurements with your group. After you come to an agreement, record your measurements in the table.

	diagonal (cm)	perimeter (cm)
square A		
square B		
square C		
square D		
square E		
square F		
square G		
square H		
square I		

- Plot the diagonal and perimeter values from the table on the coordinate plane.

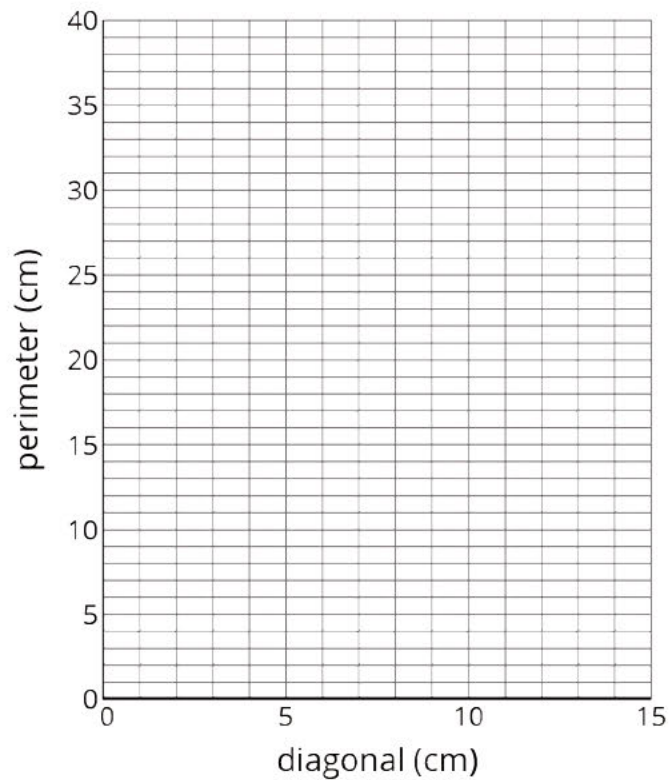

- What do you notice about the points on the graph?

Pause here so your teacher can review your work.

4. Record measurements of the other squares to complete your table.

Student Response

1. Answers vary. Each group will only have 3 of these rows filled in, and the numbers may be slightly different. The important thing is that the perimeter of each square should be a little less than 3 times the length of the diagonal. Sample responses:

	diagonal (cm)	perimeter (cm)
square A	5.7	16.1
square B	8.2	23.2
square C	3.4	9.6
square D	4.2	11.9
square E	6.8	19.2
square F	10.5	30
square G	2.2	6.2
square H	12.6	35.2
square I	5.5	15.6

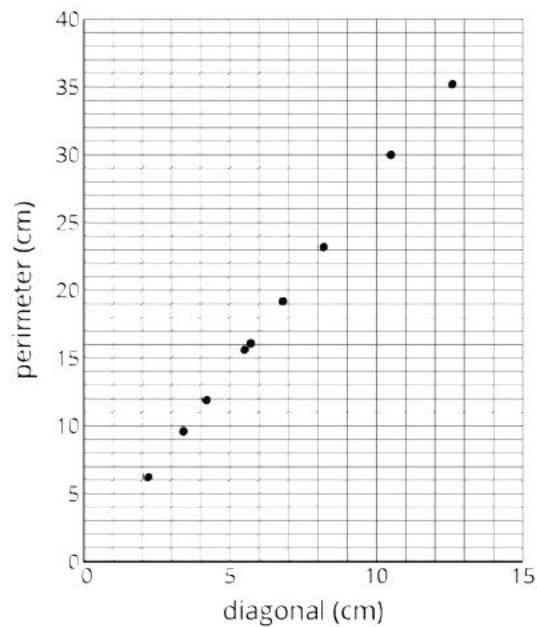

2.

3. Answers vary. Sample responses:

- The points almost lie on a straight line through the origin.
- From the graph it appears that the perimeter is about 3 times as large as the diameter.

4. See the completed table above.

Activity Synthesis

The goal of this discussion is for students to see that there is a proportional relationship between the length of the diagonal and the perimeter of a square, even though it is difficult to measure accurately enough to get an exact constant of proportionality.

First, ask students to share what they noticed about their graphs. Next, display a table like the one in students' books or devices and poll the class on the measurements they got for each square. If desired, give students 1–2 minutes to plot more points on their graph for the values they added to their tables.

Use questions like the following to lead students to the idea that the length of the diagonal and the perimeter are proportional to each other. Even though the data does not lie perfectly on a line, the inconsistencies are caused by measurement error.

- “Would it make sense to have $(0, 0)$ as a possible point?” (Yes, since a square with diagonal 0 cm would have a perimeter of 0 cm.)
- “The data is not perfectly lined up. Do you think it should be? What could be causing the inconsistencies?” (Measurement error.)
- “If you had a square with diagonal 1 cm, what would the perimeter be?” (About 2.8 cm.)

Consider adding a column to the table with the quotient of the perimeter of the square divided by the length of the diagonal to help students identify the constant of proportionality for the relationship. Sample data is included in the table below. While the level of precision of their measurements does not justify including this many decimal places for the quotients, they are shown in this sample table because it is important that students notice the variability in the numbers and come to their own realization that these quotients are all approximately 2.8.

	diagonal (cm)	perimeter (cm)	perimeter \div diagonal
square A	5.7	16.1	2.825
square B	8.2	23.2	2.841
square C	3.4	9.6	2.824
square D	4.2	11.9	2.833
square E	6.8	19.2	2.823
square F	10.5	30	2.857
square G	2.2	6.2	2.818
square H	12.6	35.2	2.793
square I	5.5	15.6	2.836

When we collect data through measurement, we usually will introduce small errors into the data. Even though the data will look a little bit “bumpy,” it will often show the underlying relationships between two quantities. In this case, we were able to use the plotted data to estimate the constant of proportionality. Once we have an estimate for the constant of proportionality, we can find other diagonal lengths given the perimeter or other perimeters given the diagonal length. In a situation like this, analyzing the graph is a powerful method to check visually to see if a relationship looks like it may be proportional. The table not only helps to confirm this but also gives the approximate constant of proportionality.

1.3 Area of a Square

15 minutes

This activity builds on the previous one as students plot a different relationship, comparing the length of each square diagonal to its area. Students use the length measurements from the previous activity and use them to calculate the area of the squares. Unlike in the previous activity, this time both the table and the graph show that the relationship between diagonal length and area is *not* close to being proportional. As a result, the measurement error does not play a role in this activity. Rather, the focus is on identifying that a relationship is not proportional: this is an example of MP7 because students will identify that there is no constant of proportionality in the table (not even allowing for measurement error) and will correspondingly notice that the plotted points are not close to lying on a line.

Addressing

- 7.RP.A.2.a

Instructional Routines

- MLR8: Discussion Supports

Launch

Keep students in the same groups. Tell them to calculate the area of the same 3 squares they measured in the previous activity. Give students 4 minutes of group work time. Display this blank grid and have students plot points for their measurements.

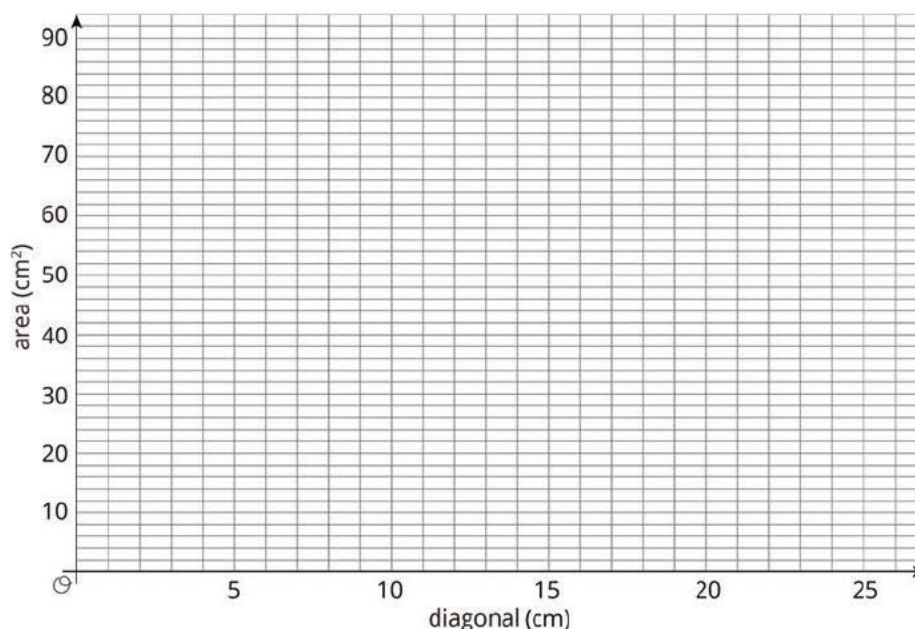

Give students 2–3 more minutes of group work time followed by whole-class discussion.

Support for Students with Disabilities

Representation: Internalize Comprehension. Activate or supply background knowledge about calculating the area of a square. Allow students to use calculators to ensure inclusive participation in the activity.

Supports accessibility for: Memory; Conceptual processing

Anticipated Misconceptions

Some students may struggle to calculate the area of the squares, or may use the length of the diagonal as if it were the side length. Prompt them with questions like “How can you calculate the area of a rectangle?” “What is the length and width of your square?”

Some students may measure the side length of each square again, instead of dividing the perimeter from the previous activity by 4. This strategy is allowable, although you can also prompt them to consider if they no longer had access to a ruler, is there a way they could use the information they already recorded to find this measurement.

Some students may struggle to organize the information. Prompt them to add a column to the table in the previous activity to record the side length of the squares.

Student Task Statement

1. In the table, record the length of the diagonal for each of your assigned squares from the previous activity. Next, calculate the area of each of your squares.

	diagonal (cm)	area (cm ²)
square A		
square B		
square C		
square D		
square E		
square F		
square G		
square H		
square I		

Pause here so your teacher can review your work. Be prepared to share your values with the class.

2. Examine the class graph of these values. What do you notice?
3. How is the relationship between the diagonal and area of a square the same as the relationship between the diagonal and perimeter of a square from the previous activity? How is it different?

Student Response

1. Three rows of this table filled in.

	diagonal (cm)	area (cm ²)
square A	5.7	16.2
square B	8.2	33.6
square C	3.4	5.8
square D	4.2	9
square E	6.8	23
square F	10.5	56.2
square G	2.2	2.4
square H	12.6	77.4
square I	5.5	15.2

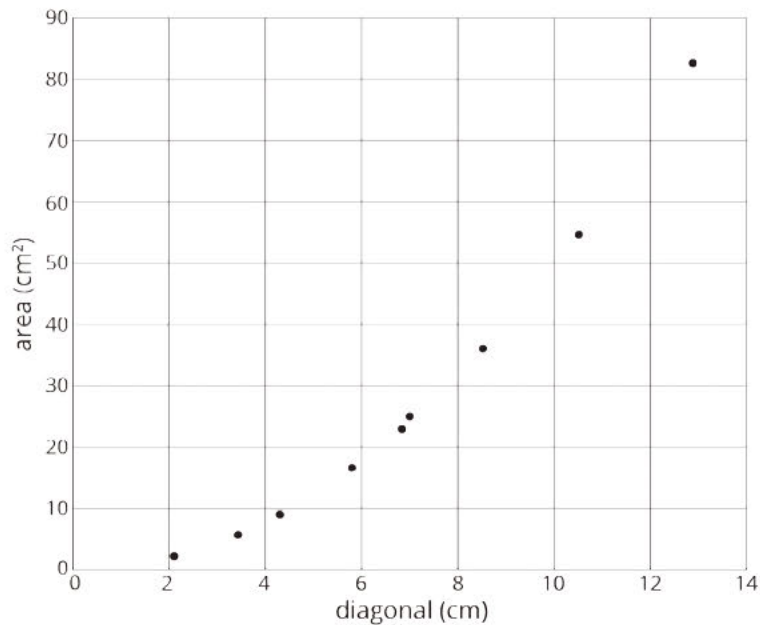

- Answers vary. Sample responses: The graph appears to curve upward. The relationship is not proportional.
- As the diagonal of a square increases, both perimeter and area increase. However, perimeter is proportional to the length of the diagonal, but area is not.

Are You Ready for More?

Here is a rough map of a neighborhood.

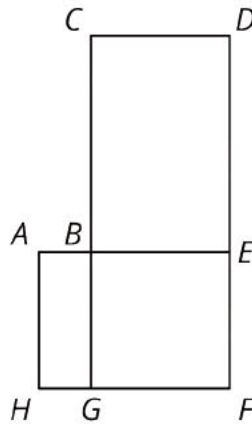

There are 4 mail routes during the week.

- On Monday, the mail truck follows the route A-B-E-F-G-H-A, which is 14 miles long.
- On Tuesday, the mail truck follows the route B-C-D-E-F-G-B, which is 22 miles long.
- On Wednesday, the truck follows the route A-B-C-D-E-F-G-H-A, which is 24 miles long.
- On Thursday, the mail truck follows the route B-E-F-G-B.

How long is the route on Thursdays?

Student Response

Thursday's route is 12 miles long.

Activity Synthesis

The goal of this discussion is for students to recognize that the relationship between the length of the diagonal and the area of squares of different sizes is not a proportional relationship.

Invite students to share their observations about the graph. Important points include:

- As the length of the diagonal increases, the area of the square increases.
- The points do not look like they lie on a line and definitely do not lie on a line that goes through $(0, 0)$.
- The area of the square looks to grow at a faster rate for larger diagonals than for the short diagonals.

To reinforce that the relationship is not proportional, instruct students to calculate the quotient of the area divided by the length of the diagonal for their square. Consider displaying a table of their measurements and adding a third column to record their quotients. Students should realize that the differences between these quotients are too large to be accounted for by just measurement error.

diagonal (cm)	area (cm ²)	area ÷ diagonal
8.2	33.6	4.1
4.2	9	2.1
6.8	23	3.4
2.2	2.4	1.1
12.6	77.4	6.1

If time permits, consider using this picture to reinforce that length scales linearly while area does not:

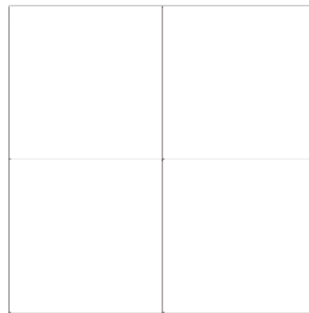

- “If the side length of the small square is s , what is the side length of the large square?” ($2s$)
- “If the diagonal of the small square is d , what is the diagonal of the large square?” ($2d$)
- “If the area of the small square is A , what is the area of the large square?” ($4A$)
- “Is the relationship between the diagonal and the area proportional?” (No, when the diagonal doubles, the area quadruples; if the relationship were proportional, both the diagonal and the area would double.)

Support for English Language Learners

Speaking, Listening: MLR8 Discussion Supports. Use this routine to support whole-class discussion. For each observation that is shared, ask students to restate what they heard using precise mathematical language. Consider providing students time to restate what they heard to a partner before selecting one or two students to share with the class. Ask the original speaker(s) if their peer was accurately able to restate their thinking. Call students' attention to any words or phrases that helped to clarify the original statement. This provides more students with an opportunity to produce language as they interpret the reasoning of others.

Design Principle(s): Support sense-making

Lesson Synthesis

Key takeaways:

- When we measure the quantities in a proportional relationship, measurement error may make it look like there is not an exact constant of proportionality.
- A graph can be helpful to decide whether the points are close to lying on a straight line.

Questions:

- “What does the graph of a proportional relationship look like?” (A straight line through the origin.)
- “If we measure the quantities in a proportional relationship and graph our measurements, what will the graph look like?” (The points will probably lie close to a straight line through the origin, but not exactly.)

Consider displaying various graphs and asking students whether they think the quantities are in a proportional relationship.

1.4 Examining Relationships

Cool Down: 5 minutes

Addressing

- 7.RP.A.2.a

Student Task Statement

1. The graph shows the height of a plant after a certain amount of time measured in days.

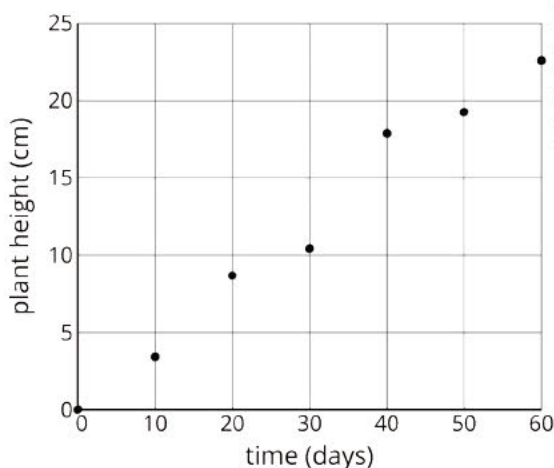

Do you think that there may be a proportional relationship between the number of days and the height of the plant? Explain your reasoning.

2. The graph shows how much snow fell after a certain amount of time measured in hours.

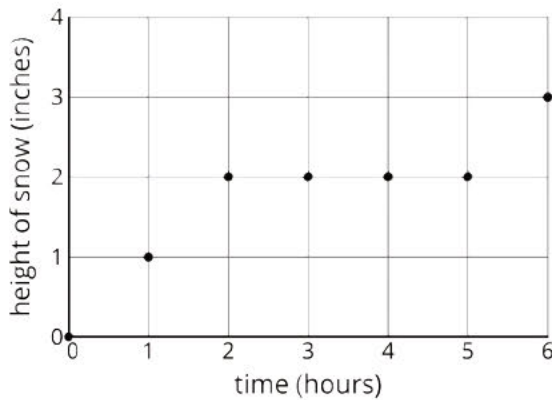

Do you think that there may be a proportional relationship between the number of hours and the amount of snow that fell? Explain your reasoning.

Student Response

1. Yes, there may be a proportional relationship. The point $(0, 0)$ is on the graph, the points are close to being on a line, and there could be measurement error. It is also possible that the relationship is not proportional. It is not possible to decide for sure from the graph.
2. No, there is not a proportional relationship. For several hours there was no snow falling while some time at the beginning and toward the end there was some snowfall.

Student Lesson Summary

When we measure the values for two related quantities, plotting the measurements in the coordinate plane can help us decide if it makes sense to model them with a proportional relationship. If the points are close to a line through $(0, 0)$, then a proportional relationship is a good model. For example, here is a graph of the values for the height, measured in millimeters, of different numbers of pennies placed in a stack.

Because the points are close to a line through $(0, 0)$, the height of the stack of pennies appears to be proportional to the number of pennies in a stack. This makes sense because we can see that the heights of the pennies only vary a little bit.

An additional way to investigate whether or not a relationship is proportional is by making a table. Here is some data for the weight of different numbers of pennies in grams, along with the corresponding number of grams per penny.

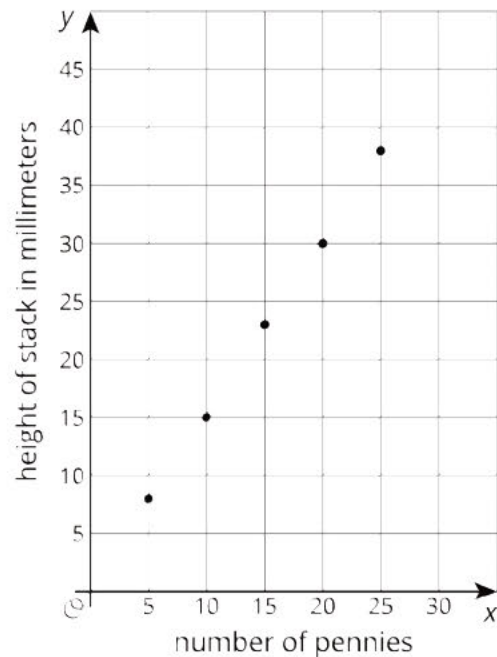

number of pennies	grams	grams per penny
1	3.1	3.1
2	5.6	2.8
5	13.1	2.6
10	25.6	2.6

Though we might expect this relationship to be proportional, the quotients are not very close to one another. In fact, the metal in pennies changed in 1982, and older pennies are heavier. This explains why the weight per penny for different numbers of pennies are so different!

Lesson 1 Practice Problems

Problem 1

Statement

Estimate the side length of a square that has a 9 cm long diagonal.

Solution

6.3 cm, because the perimeter of the square is approximately $9 \cdot 2.8$ or 25.2 cm and $\frac{25.2}{4} = 6.3$ cm.

Problem 2

Statement

Select **all** quantities that are proportional to the diagonal length of a square.

- A. Area of the square
- B. Perimeter of the square
- C. Side length of the square

Solution

["B", "C"]

Problem 3

Statement

Diego made a graph of two quantities that he measured and said, "The points all lie on a line except one, which is a little bit above the line. This means that the quantities can't be proportional." Do you agree with Diego? Explain.

Solution

Answers vary. Sample response: I don't agree with Diego, since the quantities could be proportional if the line goes through the origin. Measurements are not perfect and the relationship could be proportional.

Problem 4

Statement

The graph shows that while it was being filled, the amount of water in gallons in a swimming pool was approximately proportional to the time that has passed in minutes.

- About how much water was in the pool after 25 minutes?
- Approximately when were there 500 gallons of water in the pool?
- Estimate the constant of proportionality for the gallons of water per minute going into the pool.

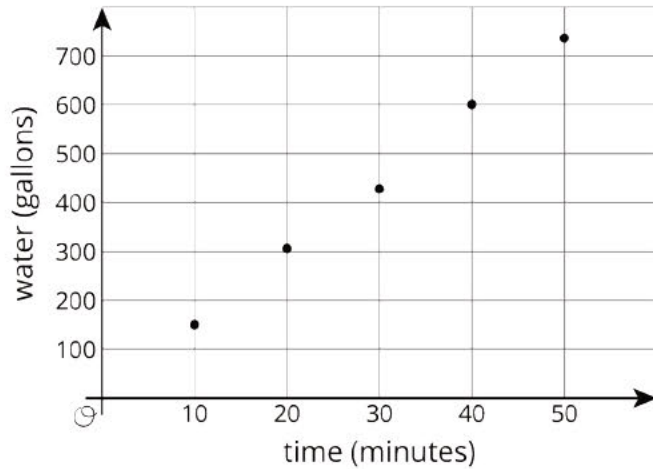

Solution

- About 380 gallons
- After about 35 minutes
- About 15

Lesson 2: Exploring Circles

Goals

- Compare (orally) different ways to measure a circle, and generalize the relationship between radius and diameter.
- Comprehend the terms “diameter,” “center,” “radius,” and “circumference” in reference to parts of a circle.
- Describe (orally and in writing) the defining characteristics of a circle.

Learning Targets

- I can describe the characteristics that make a shape a circle.
- I can identify the diameter, center, radius, and circumference of a circle.

Lesson Narrative

This is the first lesson on circles in a unit that develops and applies methods to find the circumference and area of a circle. In this lesson, students move from the informal idea of a circle as “a round figure” to the more formal definition that a **circle** is the set of points that are equally distant from the *center*, enclosing a circular region.

Students discover characteristics of a circle by examining examples and non-examples. They gain experience drawing circles with a compass. (For classrooms that do not have access to compasses, a digital version of the activity is provided.) They develop the idea that the size of a circle can be measured by its **diameter**, **radius**, **circumference**, or the enclosed area, depending on the context. We will often use phrases like “What is the diameter of the circle?” to mean “What is the length of a diameter of the circle?”

Alignments

Addressing

- 7.G.A: Draw, construct, and describe geometrical figures and describe the relationships between them.
- 7.G.A.2: Draw (freehand, with ruler and protractor, and with technology) geometric shapes with given conditions. Focus on constructing triangles from three measures of angles or sides, noticing when the conditions determine a unique triangle, more than one triangle, or no triangle.

Building Towards

- 7.G.B.4: Know the formulas for the area and circumference of a circle and use them to solve problems; give an informal derivation of the relationship between the circumference and area of a circle.

Instructional Routines

- MLR3: Clarify, Critique, Correct
- MLR5: Co-Craft Questions
- MLR8: Discussion Supports
- Take Turns
- Think Pair Share

Required Materials

Compasses

Pre-printed slips, cut from copies of the

blackline master

Rulers

Required Preparation

You will need the Sorting Round Objects blackline master for this lesson. Prepare 1 copy per 2--3 students, and cut them up ahead of time. These slips can be reused from one class to the next. If possible, copy each complete set on a different color of paper, so that a stray slip can quickly be put back.

Student Learning Goals

Let's explore circles.

2.1 How Do You Figure?

Warm Up: 5 minutes

This warm-up prompts students to compare two figures and use the characteristics of those figures to help them sketch a possible third figure that has various characteristics of each. It invites students to explain their reasoning and hold mathematical conversations (MP3), and allows you to hear how they use terminology and talk about figures and their properties before beginning the upcoming lessons on circles. There are many good answers to the question and students should be encouraged to be creative. Encourage students to use multiple geometrical properties to create their third figure. The grid is given to allow students the opportunity to discuss side lengths, find area and perimeter of Figure A, as well as estimate dimensions of Figure B.

Addressing

- 7.G.A

Instructional Routines

- Think Pair Share

Launch

Arrange students in groups of 2–4. Display the image of the two figures for all to see. Make sure students understand they are to draw a third Figure, C, that has features of both Figure A and B but more closely resembles Figure A. Give students 2 minutes of quiet think time to sketch Figure C and

then time to share their thinking with their group. After everyone has conferred in groups, ask the group to share the characteristics used in generating different versions of Figure C, and to show an example of one of the sketches.

Student Task Statement

Here are two figures.

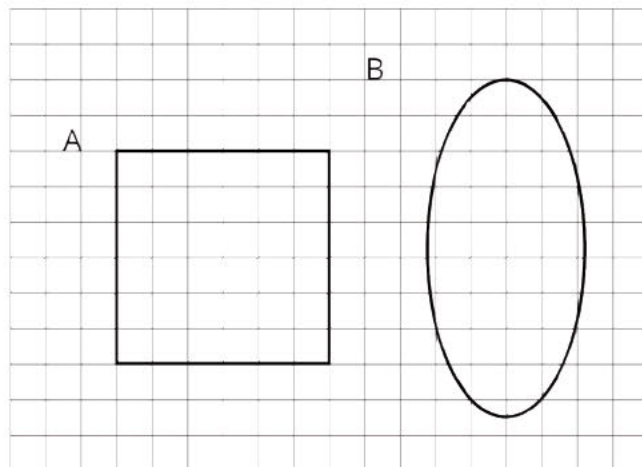
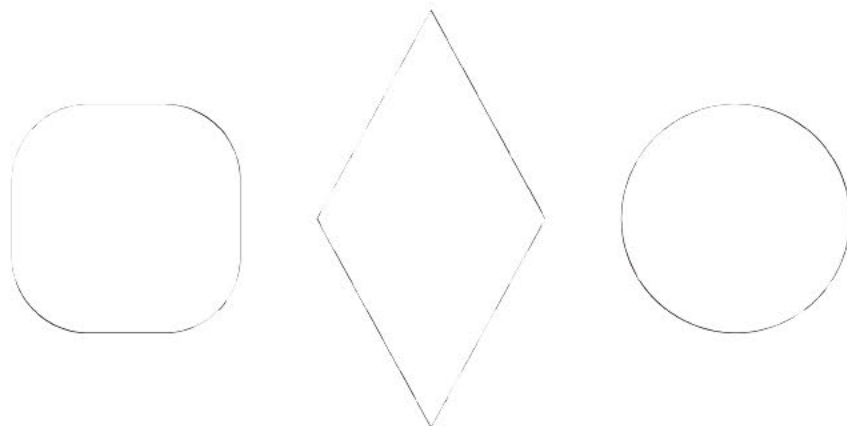

Figure C looks more like Figure A than like Figure B. Sketch what Figure C might look like. Explain your reasoning.

Student Response

Answers vary. Possible solutions:



- This first possibility for Figure C is almost identical to Figure A but with slightly rounded corners like Figure B. Both in size and shape, it is closer to Figure A.
- This second possibility for Figure C is a polygon (quadrilateral, parallelogram, and rhombus) like Figure A, but it is taller than it is wide like Figure B.
- This third possibility for Figure C resembles Figure A in that it is the same distance across the figure, from left to right or from top to bottom. Also like Figure A, it can be rotated, and it still

look exactly the same. It looks like Figure B in that its sides are curved rather than straight line segments.

Activity Synthesis

After students have conferred in groups, invite each group to share the characteristics that were important to them in creating their third figure. Some important points to be brought out include

- Figure A is a polygon, and Figure B is not a polygon.
- Figure A has the same width and height while the height and width of Figure B are very different.
- The area of Figure A is 36 square units while the area of Figure B is about 30 square units.
- The perimeter of Figure A is 24 units. The perimeter of Figure B is hard to determine, but it is less, maybe about 22 units.

Encourage students to be as precise as possible as they describe why they chose the figure they drew.

Display the responses for all to see. Since there is no single correct answer to the question, attend to students' explanations and ensure the reasons given are correct. During the discussion, prompt students to explain the meaning of any terminology they used. Also, press students on unsubstantiated claims.

2.2 Sorting Round Objects

20 minutes

The purpose of this activity is to build on students' prior experience with circles and help them refine their definition of a circle. First, students sort pictures of round objects based on whether or not they are circular. Then, they compare the size of the circles to begin a discussion of what aspects of a circle can be measured. Lastly, the teacher introduces the terms **diameter**, **center**, **radius**, and **circumference**, so students can identify these measurements in the pictures of the circular objects. When students focus on what shapes have in common and describe their common features (and the deviations of non-examples) to build a definition, they are expressing regularity in repeated reasoning (MP8).

Since all of the objects pictured are three dimensional and circles are not, encourage students to focus on the circular (and non circular) *aspects* of the objects. For example, the utility hole cover is actually a cylinder with a relatively short height, but the outline of the utility hole cover is circular. Some of the pictures could reasonably be placed into either category. For example, the outline of the pizza is not a complete circle, but the outline of a slice of pepperoni may be. The final categorization is not as important as students' reasoning about what makes something a circle.

In the second-to-last question, the use of the words smallest and largest is purposefully vague to encourage students to reason about the measurable things in a circle. As they work, listen for: how students define size, the ways they determine the size, estimation strategies and any actual

estimations, specifically diameter, radius, circumference, or area of the circle. These will all be important in the whole-group discussion.

You will need the Sorting Round Objects blackline master for this activity.

Addressing

- 7.G.A

Building Towards

- 7.G.B.4

Instructional Routines

- MLR5: Co-Craft Questions
- Take Turns

Launch

Arrange students in groups of 2–3. Distribute slips with the pictures of round objects. Give students 1 minute of quiet think time to come up with categories they could use to sort the objects pictured, followed by 1 minute to share their ideas with their partner. Select students to share their ideas for sorting the objects into 2 categories. After a student suggests they could be sorted by whether or not the objects are circular, instruct the students to do that.

Demonstrate how to conduct the sorting activity. Choose a student to act as your partner. Select one card and then explain to your partner why you think the object is or is not circular. Demonstrate productive ways to agree or disagree, e.g., by explaining your mathematical thinking, asking clarifying questions, etc.

After sorting is complete, pause their work for a quick whole-group discussion. Poll the class on which of the objects they sorted into the *not circular* category. Ask students to explain why each of these objects is not circular. Start a list titled “Characteristics of a Circle” displayed for all to see. For each reason students give as to why one of the objects is not circular, add the related characteristic of a circle onto your list. Here is a table showing sample responses. The first two columns show what could be mentioned in the discussion and the third column shows what could be added to your displayed list.

picture(s)	reason it is not a circle	characteristic of a circle
clock	straight edges and vertices	round, no corners
rug	straight sides (and taller than it is wide)	no straight sides
boiled egg and platter	taller than they are wide	the same distance across in every direction: length, width, height, longest diagonal
pizza and speedometer	The outer edges would be circles if they went all of the way around, but they do not.	closed figure
basketball	encloses a three-dimensional region	encloses a two-dimensional region

Next, instruct students to put the pictures of objects that are *not circular* off to the side and focus on the objects that are circular for the rest of the activity.

Support for English Language Learners

Writing, Representing, Conversing: MLR5 Co-craft Questions. Use this routine to get students in the mindset of observing objects and to develop descriptive language to distinguish between objects that are circular and those that are not. Begin by showing only the blackline master, and do not present the activity yet. Ask students to jot down possible mathematical questions that could be asked about the images. This invites participation from all students and lowers the pressure for using specific math language yet. After a minute or two of think time, invite students to compare their questions with a partner. Conclude the routine by asking some pairs to share their questions aloud with the class before moving on to the original activity. *Design Principle(s): Maximize meta-awareness; Cultivate conversation*

Anticipated Misconceptions

Some students may answer that the basketball is a circle, because the paper can only show a two-dimensional projection of the three-dimensional object. Tell them that a real basketball is a sphere, not a circle. If desired, prompt them to describe what *aspect* of a basketball is a circle. (The equator.)

Some students may think that the pizza and speedometer are circles, not paying attention to the fact that their circular outlines are not complete.

In the last part of the discussion, after introducing the terms, students may try to identify parts of a circle on the objects that were not circles. For example, they may think that the minute hand on the

hexagonal clock represents the radius. Point out that the hand of the clock reaches closer to the midpoint of each edge than it does to each vertex, because the clock is not a circle.

Student Task Statement

Your teacher will give you some pictures of different objects.

1. How could you sort these pictures into two groups? Be prepared to share your reasoning.
2. Work with your partner to sort the pictures into the categories that your class has agreed on. Pause here so your teacher can review your work.
3. What are some characteristics that all **circles** have in common?
4. Put the circular objects in order from smallest to largest.
5. Select one of the pictures of a circular object. What are some ways you could measure the actual size of your circle?

Student Response

1. Answers vary. Sample responses:
 - things I've seen before and things I haven't
 - bigger than my desk and smaller than my desk
 - circles and non-circles
2. Answers vary. Sample responses:

Circles:	Not circles:
<ul style="list-style-type: none">◦ outline of the wagon wheel, utility hole cover, grill, fan cover, bike wheel, glow necklace, orange slice, or dartboard◦ path of the yo-yo, propeller tip, or center pivot irrigation◦ edge of a pepperoni slice, or inside some numbers on the clock◦ equator of the basketball	<ul style="list-style-type: none">◦ outline of the clock, rug, boiled egg, platter, pizza, speedometer, or orange slice◦ surface of the basketball
3. Circles are round, closed plane figures. They do not have edges or vertices. Their length, width, and longest diagonal in any direction are all equal. The distance from the center to any point around the circle is always the same. Circles have 360 degrees and infinitely many lines of symmetry.
4. Answers vary. Sample response: pepperoni, glow necklace, dartboard, bike wheel, grill, utility hole cover, fan cover, wagon wheel, yo-yo trick, airplane propeller, center pivot irrigation.

5. Answers vary. Sample responses:

- the longest line across a circle.
- the distance from the center to the edge (when the center of a circle is visible).
- the perimeter around a circle.
- how many square units fit inside a circle.
- the largest square that fits inside or the smallest square that fits outside a circle.

Are You Ready for More?

On January 3rd, Earth is 147,500,000 kilometers away from the Sun. On July 4th, Earth is 152,500,000 kilometers away from the Sun. The Sun has a radius of about 865,000 kilometers.

Could Earth's orbit be a circle with some point in the Sun as its center? Explain your reasoning.

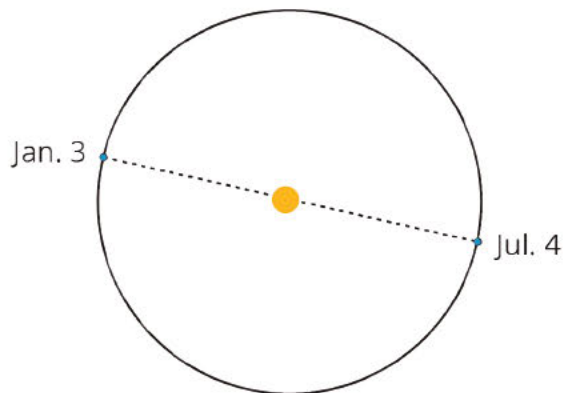

Student Response

No. The diameter of the Sun is less than 2 million kilometers. Even subtracting 2 million kilometers from the largest distance between Earth and the Sun and adding 2 million kilometers to the shortest distance between Earth and the Sun, the distances are still different. So no matter what point in the Sun we try to use as the center of the orbit, the distances are not the same and so the orbit is not circular.

Activity Synthesis

The goal of this final discussion is to introduce terms that describe measurable aspects of circles. Invite selected students to share their reasoning and estimates about the relative sizes of the circles. Make sure that students articulate which *aspect* of the objects are circles (for example, the outline of the utility hole cover or the path of the yo-yo trick), since all of the objects are actually three dimensional.

Ask students to defend their order by estimating how big each circle is. Wait for the ambiguity of “what part of the circle are we measuring” to come up, or point out that different students are (likely) using different attributes when discussing the size of the circle. Challenge students to explain themselves with more precision and then introduce the terms diameter, center, radius, and circumference as they relate to the parts being measured.

Some important points to cover include:

- Circles are one-dimensional figures that enclose a two-dimensional region.
- The size of a circle can be described using the length of its diameter—a segment with its endpoints on the circle that passes through the center. Any two diameters of the same circle have the same length. We will often use phrases like “What is the diameter of the circle?” to mean “What is the length of a diameter of the circle?”
- The circumference is the length around the circle.
- A radius is a line segment from the center of a circle to any point on the circle. Its length is half of the diameter.

Ask students to identify pictures from the activity that draw attention to the radius, to the diameter, and to the circumference, and ask how they decided. If students do not mention all examples, point them out:

- The radius is depicted in the wagon wheel, yo-yo trick, pivot irrigation, orange slice, dartboard, and airplane propeller.
- The diameter is depicted in the wagon wheel, dartboard, and grill.
- The circumference is depicted in all the circles but is especially prominent in the glow necklace and yo-yo trick.

Give students a minute to write down what each of the new terms means, using words or diagrams.

Lastly, display the picture of the grill, utility hole cover, or bike wheel for all to see. Draw students’ attention to some of the other lines (chords) that are not the diameter or the radius. Ask whether these lines depict the diameter or radius and why not.

Support for Students with Disabilities

Representation: Develop Language and Symbols. Create a display of important terms and vocabulary. Invite students to suggest language or diagrams to include that will support their understanding of: diameter, center, radius, and circumference.

Supports accessibility for: Memory; Language

2.3 Measuring Circles

5 minutes

The purpose of this activity is to continue developing the idea that we can measure different attributes of a circle and to practice using the terms diameter, radius, and circumference. Students reason about these attributes when three different-sized circles are described as “measuring 24 inches” and realize that the 24 inches must measure a different attribute of each of the circles. Describing specifically which part of a circle is being measured is an opportunity for students to attend to precision (MP6).

Addressing

- 7.G.A

Building Towards

- 7.G.B.4

Instructional Routines

- MLR8: Discussion Supports

Launch

Keep students in the same groups. Give students 2 minutes of quiet work time followed by partner discussion.

Support for Students with Disabilities

Action and Expression: Develop Expression and Communication. Invite students to talk about their ideas with a partner before writing them down. Display sentence frames to support students when they explain their ideas. For example: “That could/couldn’t be true because....” or “I agree because....”

Supports accessibility for: Language; Organization

Anticipated Misconceptions

Students may think they are all the same size object because they are only focusing on the 24 inches. Ask students to describe each of the objects to make it clear they are not the same size.

Student Task Statement

Priya, Han, and Mai each measured one of the circular objects from earlier.

- Priya says that the bike wheel is 24 inches.
- Han says that the yo-yo trick is 24 inches.
- Mai says that the glow necklace is 24 inches.

1. Do you think that all these circles are the same size?
2. What part of the circle did each person measure? Explain your reasoning.

Student Response

1. The three objects are not the same size. They are each measuring different parts of the circle.
2. Priya is most likely measuring the diameter of the bike wheel because a radius of 24 inches would be very large for a bike wheel, and a circumference of 24 inches would be very small. Han is most likely measuring the radius of the yo-yo trick because a diameter or circumference of 24 inches would be very small. Mai is most likely measuring the circumference of the glow necklace because a radius or diameter of 24 inches would be very large.

Activity Synthesis

Ask one or more students to share their choices for diameter, radius, or circumference as the measurement of the three circles. Prompt students to explain their reasoning until they come to an agreement.

Display this image of the bike wheel and the airplane propeller to discuss the relationship between radius, r , and diameter, d , of a circle: $d = 2r$. When drawn to the same scale, the airplane propeller and bike wheel would look like this:

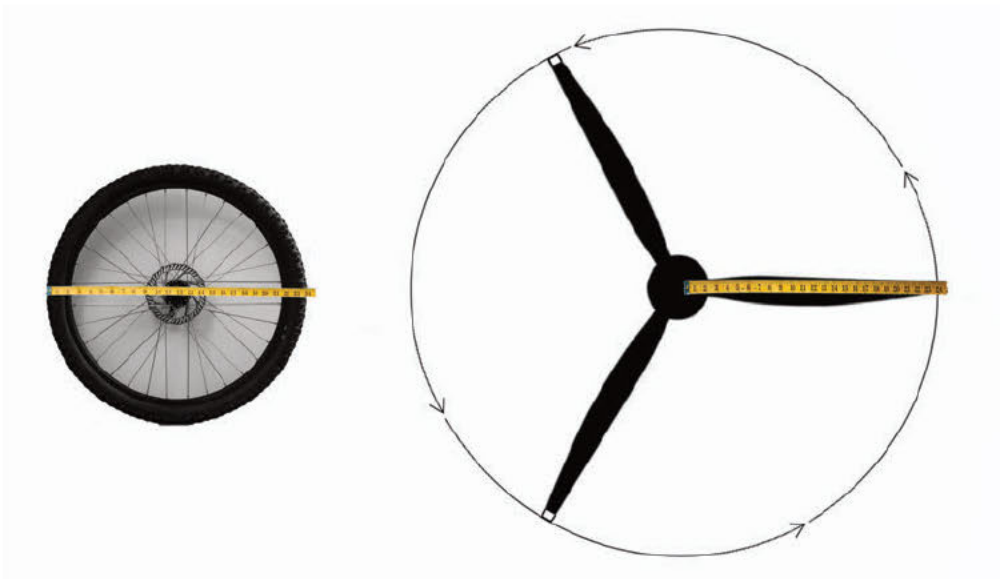

Future lessons will address the relationship between the circumference of a circle and the diameter.

Support for English Language Learners

Speaking, Representing: MLR8 Discussion Supports. Use this routine to support whole-class discussion. After each student shares their choices for diameter, radius, or circumference as the measurement of the three circles, provide the class with the following sentence frames to help them respond: "I agree because" or "I disagree because" Encourage students to use precise language to refer to the different attributes of a circle as part of their explanation for why they agree or disagree.

Design Principle(s): Optimize output (for explanation)

2.4 Drawing Circles

Optional: 10 minutes (there is a digital version of this activity)

The purpose of this activity is to reinforce students' understanding of the terms diameter, center, and radius and also for students to see what a compass is good for (MP5).

Before using the compass, students first attempt to draw a circle freehand. Then, they recognize the compass as a strategic tool for drawing circles. However, the compass is useful not just for drawing circles but also for transferring lengths from one location to another for many different purposes. Students will apply this understanding in later units, for example, when they construct a triangle given the lengths of its three sides. This activity prepares students for that application by asking them to make the radius of the circle match another length they have already drawn.

If this is a student's first time using a compass, direct instruction may be needed on how to use one. The circles students draw may not be perfect, but as they gain more experience with a compass, they will improve. A digital version of the activity is provided for classrooms that do not have access to compasses but do have access to appropriate electronic devices.

As students work, monitor and select students who are correctly using the relationship between the diameter and radius to draw Circles C and D and other students who are recreating each of the different images from question 5 to share during the discussion.

Addressing

- 7.G.A.2

Instructional Routines

- MLR3: Clarify, Critique, Correct

Launch

Distribute rulers. Give students a few minutes of quiet work time for the first two questions. If a student asks for a circular object to trace, graph paper, a protractor, or a compass, make that available. After drawing Circles A and B, but before drawing Circles C and D, ask students "What was

difficult about drawing the circles? How they could make their drawings more precise? and What tools might be helpful?" Once students realize that a compass would be a good tool for this task, distribute compasses to all students.

If using the digital activity, students will have the opportunity to create circles using an applet for questions 1–4. They will need a compass to complete question 5.

Support for Students with Disabilities

Action and Expression: Provide Access for Physical Action. Provide access to tools and assistive technologies such as the applet, enlarged graph paper, and a compass. Some students may benefit from a checklist or list of steps to be able to use the applet and compass.

Supports accessibility for: Organization; Conceptual processing; Attention

Anticipated Misconceptions

Some students might think that they need a protractor to draw a circle. Allow them access to one. They may trace the outline of the protractor twice with tracings of straight sides coinciding. Ask them whether their traced shape meets all of the characteristics of a circle that were listed in the previous activity.

Once students start using the compasses, they may draw a circle with a radius of 6 cm instead of a diameter of 6 cm for Circle A. Remind them what diameter means and ask them to measure the diameter of their circle. When they realize it is incorrect for Circle A, tell them not to erase it yet. They might realize later that this is the answer for Circle C.

When recreating the given designs, students might struggle to know where to place their compasses. For the first design, the non-pencil end of the compass stays in the same place the whole time. For the second, third, and fourth designs, guide students to think about where to put the non-pencil end so that the circles will end up where they should go. For the second and fourth design, they should line up the pencil end of the compass on a point on the circle(s) they have already drawn. Similarly for the third design, students should line up the non-pencil end of the compass on a point of the circle(s) they have already drawn.

Student Task Statement

Draw and label each circle.

1. Circle A, with a **diameter** of 6 cm.
2. Circle B, with a **radius** of 5 cm. Pause here so your teacher can review your work.
3. Circle C, with a radius that is equal to Circle A's diameter.
4. Circle D, with a diameter that is equal to Circle B's radius.
5. Use a compass to recreate one of these designs.

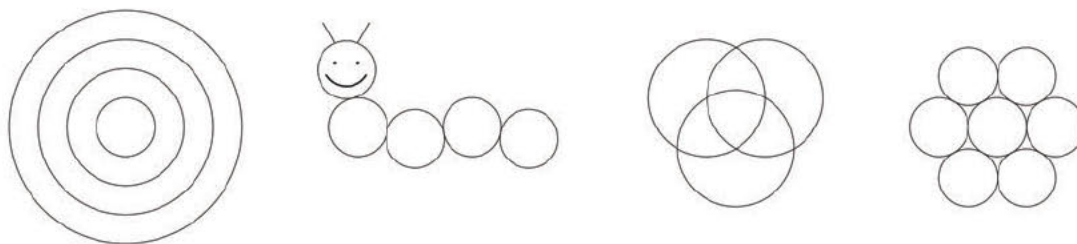

Student Response

1–4. Answers vary.

5. Images should look close to the images given.

Activity Synthesis

The main goal for this discussion is for students to connect their use of a compass to the fact that any point on a circle is the same distance from the center.

Ask selected students to share their strategies for drawing Circles C and D. Highlight the relationship that $d \div 2 = r$ for diameter d and radius r after each.

Ask selected students who recreated the first design to display their drawing. Ask “What is the same about all of these circles? What is different?” Students should notice they all have the same center, but different radii, diameters, and circumferences, but if they do not, make it known.

Ask selected students who recreated the second, third, or fourth design to display their drawing and ask “What is the same about all of these circles? What is different?” They all have the same radius, diameter, and circumference, but different centers.

Support for English Language Learners

Speaking, Listening, Writing: MLR3 Clarify, Critique, Correct. Use this routine to help students learn to critically observe how others interpret and use the terms radius and diameter in their drawings and explanations. Draw a circle that is incorrectly measured for Circle D. Display the following statement: “Circle D should be bigger than Circle B because diameters are bigger than radii.” Ask students whether this is true and ask them to write down a way they could improve this statement. Encourage students to explain the error by using the terms “radius” and “diameter.” Students should again partner share and improve their statements. End with students showing and explaining correctly-drawn diagrams of circles.

Design Principle(s): Cultivate conversation; Maximize meta-awareness

Lesson Synthesis

The main ideas are:

- A **circle** consists of all points that are the same distance to a point called the *center*. Circles enclose a circular region.
- Measurable attributes of a circle include: **radius**, **diameter**, **circumference**, and its enclosed area.
- We can draw a circle using a compass if we know the radius or diameter.

Since all radii of a circle have the same length, all diameters of a circle also have the same length: $d = 2r$ if d represents the diameter and r represents the radius.

Discussion questions:

- Show one example of a circle and one of a non-circle and ask “Why is this a circle and this is not?”
- “How can we measure the size of a circle?”
- “What can a compass help us do?”

2.5 Comparing Circles

Cool Down: 5 minutes

Addressing

- 7.G.A

Anticipated Misconceptions

Students might not realize that the diameter or radius of a circle can be drawn at any endpoint that connects to the center.

Student Task Statement

Here are two circles. Their centers are A and F .

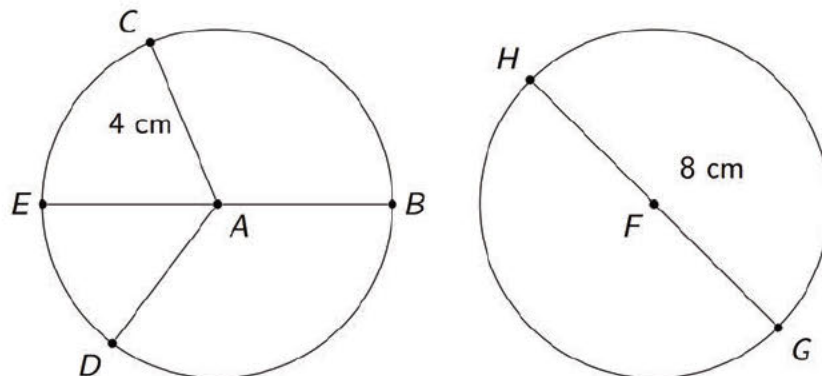

1. What is the same about the two circles? What is different?
2. What is the length of segment AD ? How do you know?

3. On the first circle, what segment is a diameter? How long is it?

Student Response

1. Because they are both circles, they are both round figures, without corners or straight sides, enclosing a two-dimensional region, that are the same distance across (through the center) in every direction. Both circles are the same size. They have the same diameter, radius, and circumference. The only difference is which additional segments (radii) are drawn.
2. Segment AD is 4 cm long because it is also a radius of the circle.
3. The diameter, segment EB , is 8 cm long.

Student Lesson Summary

A **circle** consists of all of the points that are the same distance away from a particular point called the *center* of the circle.

A segment that connects the center with any point on the circle is called a **radius**. For example, segments QG , QH , QI , and QJ are all radii of circle 2. (We say one radius and two radii.) The length of any radius is always the same for a given circle. For this reason, people also refer to this distance as the *radius* of the circle.

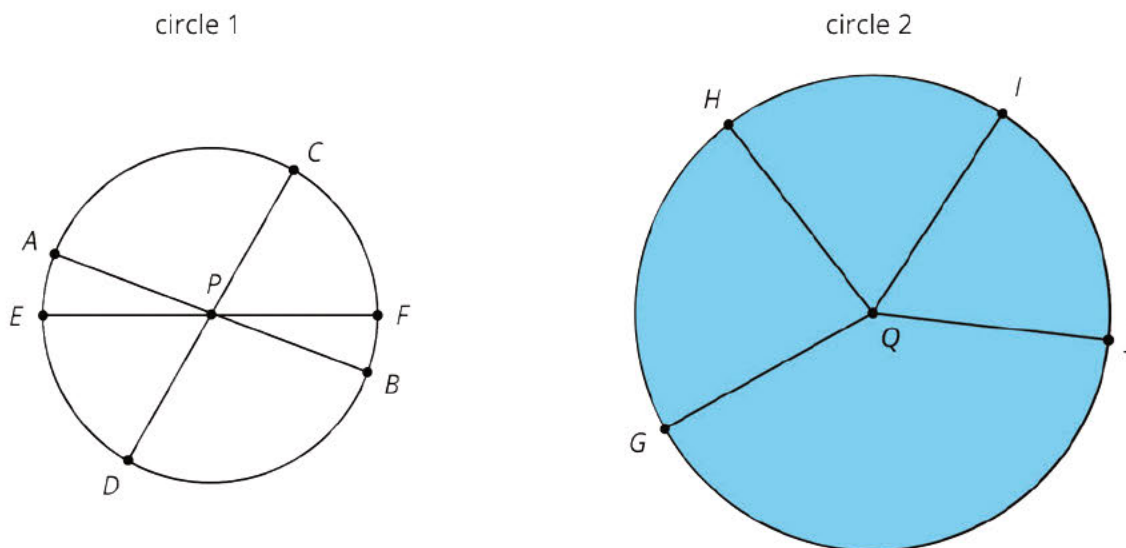

A segment that connects two opposite points on a circle (passing through the circle's center) is called a **diameter**. For example, segments AB , CD , and EF are all diameters of circle 1. All diameters in a given circle have the same length because they are composed of two radii. For this reason, people also refer to the length of such a segment as the *diameter* of the circle.

The **circumference** of a circle is the distance around it. If a circle was made of a piece of string and we cut it and straightened it out, the circumference would be the length of that string. A circle always encloses a circular region. The region enclosed by circle 2 is shaded, but the region enclosed by circle 1 is not. When we refer to the area of a circle, we mean the area of the enclosed circular region.

Glossary

- circle
- circumference
- diameter
- radius

Lesson 2 Practice Problems

Problem 1

Statement

Use a geometric tool to draw a circle. Draw and measure a radius and a diameter of the circle.

Solution

Answers vary.

Problem 2

Statement

Here is a circle with center H and some line segments and curves joining points on the circle.

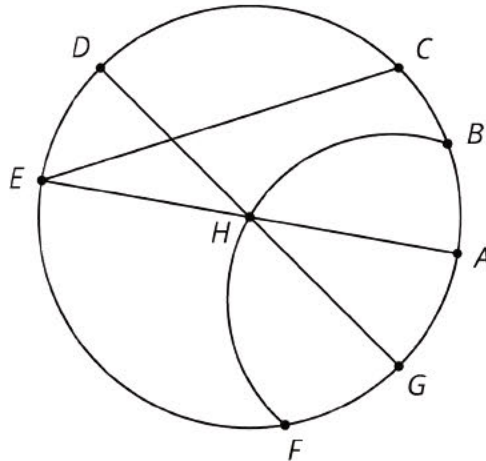

Identify examples of the following. Explain your reasoning.

- Diameter
- Radius

Solution

- Segments AE and DG . They are line segments that go through the center of the circle with endpoints on the circle.
- Segments AH , DH , EH , and GH are radii. They are line segments that go from the center to the circle.

Problem 3

Statement

Lin measured the diameter of a circle in two different directions. Measuring vertically, she got 3.5 cm, and measuring horizontally, she got 3.6 cm. Explain some possible reasons why these measurements differ.

Solution

Two diameters of a circle should have the same length. Explanations vary. Possible explanations:

- These measurements could be rounded, not exact.
- The thickness of the circle could have affected the measurements.
- Lin did not measure across the widest part when measuring vertically.
- The shape is not quite a circle, because a perfect circle is very hard to draw.

Problem 4

Statement

A small, test batch of lemonade used $\frac{1}{4}$ cup of sugar added to 1 cup of water and $\frac{1}{4}$ cup of lemon juice. After confirming it tasted good, a larger batch is going to be made with the same ratios using 10 cups of water. How much sugar should be added so that the large batch tastes the same as the test batch?

Solution

2.5 cups since the larger batch is 10 times larger (for the water $10 \div 1 = 10$) and $10 \cdot \frac{1}{4} = 2.5$.

(From Unit 2, Lesson 1.)

Problem 5

Statement

The graph of a proportional relationship contains the point with coordinates (3, 12). What is the constant of proportionality of the relationship?

Solution

4

(From Unit 2, Lesson 13.)

Lesson 3: Exploring Circumference

Goals

- Comprehend the word “pi” and the symbol π to refer to the constant of proportionality between the diameter and circumference of a circle.
- Create and describe (in writing) graphs that show measurements of circles.
- Generalize that the relationship between diameter and circumference is proportional and that the constant of proportionality is a little more than 3.

Learning Targets

- I can describe the relationship between circumference and diameter of any circle.
- I can explain what π means.

Lesson Narrative

In this lesson, students discover that there is a proportional relationship between the diameter and circumference of a circle. They use their knowledge from the previous unit on proportionality to estimate the constant of proportionality. Then they use the constant to compute the diameter given the circumference (and vice versa) for different circles. We define π as the value of the constant and discuss various commonly used approximations. In the next lesson, students use various approximations for pi to do computations. Also, relating the circumference to the radius is saved for the next lesson.

Determining that the relationship between the circumference and diameter of circles is proportional is an example of looking for and making use of structure (MP7).

Alignments

Building On

- 2.MD.A: Measure and estimate lengths in standard units.
- 6.SP.B.5.c: Giving quantitative measures of center (median and/or mean) and variability (interquartile range and/or mean absolute deviation), as well as describing any overall pattern and any striking deviations from the overall pattern with reference to the context in which the data were gathered.

Addressing

- 7.G.B.4: Know the formulas for the area and circumference of a circle and use them to solve problems; give an informal derivation of the relationship between the circumference and area of a circle.
- 7.RP.A.2: Recognize and represent proportional relationships between quantities.

- 7.RP.A.2.a: Decide whether two quantities are in a proportional relationship, e.g., by testing for equivalent ratios in a table or graphing on a coordinate plane and observing whether the graph is a straight line through the origin.

Building Towards

- 7.G.B.4: Know the formulas for the area and circumference of a circle and use them to solve problems; give an informal derivation of the relationship between the circumference and area of a circle.

Instructional Routines

- MLR7: Compare and Connect
- Notice and Wonder
- Think Pair Share

Required Materials

Cylindrical household items
Empty toilet paper roll

Measuring tapes

Required Preparation

Household items: collect circular or cylindrical objects of different sizes, with diameters from 3 cm to 25 cm. Each group needs 3 items of relatively different sizes. Examples include food cans, hockey pucks, paper towel tubes, paper plates, CD's. Record the diameter and circumference of the objects for your reference during student work time.

The empty toilet paper roll is for optional use during the warm-up as a demonstration tool.

You will need one measuring tape per group of 2--4 students. Alternatively, you could use rulers and string.

Student Learning Goals

Let's explore the circumference of circles.

3.1 Which Is Greater?

Warm Up: 5 minutes

The purpose of this warm-up is to help students visualize circumference as a linear measurement, in preparation for examining the relationship between diameter and circumference in the next activity. Some students may be able to imagine unrolling the tube into a rectangle in order to compare its length and width. Other students may benefit from hands on experience with a real toilet paper tube.

Building On

- 2.MD.A

Building Towards

- 7.G.B.4

Instructional Routines

- Think Pair Share

Launch

Arrange students in groups of 2. Display the image for all to see. Ask students to indicate when they have reasoning to support their response. Give students 1 minute of quiet think time and then time to share their thinking with their group.

Anticipated Misconceptions

Students may not understand what is meant by the height of the tube because it can sit in two different ways. Point these students to the first picture of the tube, and ask them to identify the height as the tube is sitting in that picture.

Student Task Statement

Clare wonders if the height of the toilet paper tube or the distance around the tube is greater. What information would she need in order to solve the problem? How could she find this out?

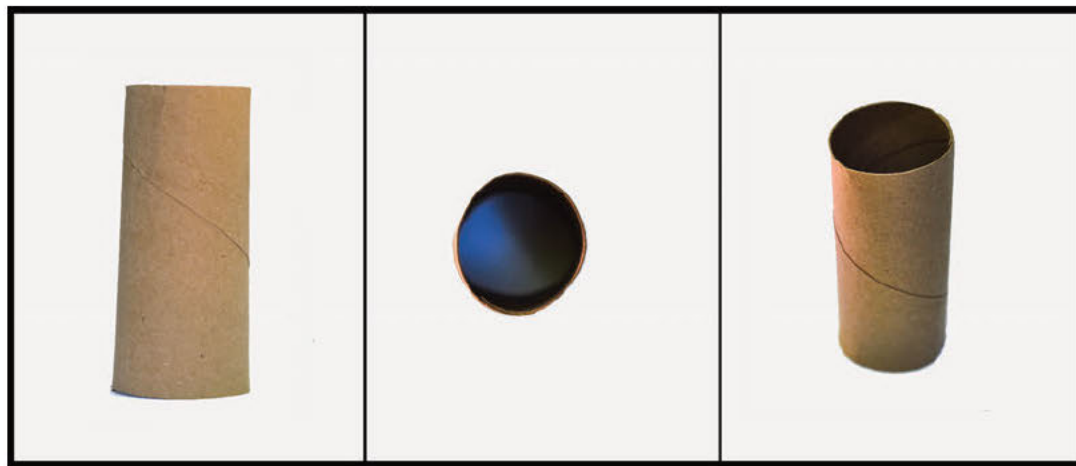

Student Response

Clare needs to measure the length of the tube and the distance around. To find the distance around she could measure the tube with a flexible measuring tape, or cut and flatten the tube.

Activity Synthesis

Poll students on which length they think is greater. Consider re-displaying the image for reference while students are explaining what they saw. To involve more students in the conversation, consider asking some of the following questions:

- What was important to you when making your decision?
- Did anyone think about the measurements in a different way?
- Do you agree or disagree? Why?
- What information do you think would help you make a better decision? If an actual toilet paper tube is available, demonstrate measuring the tube by unrolling the tube to measure the circumference and height.

It turns out that for a standard toilet paper tube, the distance around is greater than the distance from top to bottom.

3.2 Measuring Circumference and Diameter

25 minutes (there is a digital version of this activity)

In this activity, students measure the diameter and circumference of different circular objects and plot the data on a coordinate plane, recalling the structure of the first activity in this unit where they measured different parts of squares. Students use a graph in order to conjecture an important relationship between the circumference of a circle and its diameter (MP 5). They notice that the two quantities appear to be proportional to each other. Based on the graph, they estimate that the constant of proportionality is close to 3 (a table of values shows that it is a little bigger than 3). This is their first estimate of pi.

This activity provides good, grade-appropriate evidence that there is a constant of proportionality between the circumference of a circle and its diameter. Students will investigate this relationship further in high school, using polygons inscribed in a circle for example.

To measure the circumference, students can use a flexible measuring tape or a piece of string wrapped around the object and then measure with a ruler. As students measure, encourage them to be as precise as possible. Even so, the best precision we can expect for the proportionality constant in this activity is “around 3” or possibly “a little bit bigger than 3.” This could be a good opportunity to talk about how many digits in the answer is reasonable. To get a good spread of points on the graph, it is important to use circles with a wide variety of diameters, from 3 cm to 25 cm. If there are points that deviate noticeably from the overall pattern, discuss how measurement error plays a factor.

As students work, monitor and select students who notice that the relationship between diameter and circumference appears to be proportional, and ask them to share during the whole-group discussion.

If students are using the digital version of the activity, they don’t necessarily need to measure physical objects, but we recommend they do so anyway.

Building On

- 6.SP.B.5.c

Addressing

- 7.G.B.4
- 7.RP.A.2.a

Instructional Routines

- MLR7: Compare and Connect
- Notice and Wonder

Launch

Arrange students in groups of 2–4. Distribute 3 circular objects and measuring tapes or string and rulers to each group. Especially if using string and rulers, it may be necessary to demonstrate the method for measuring the circumference.

Ask students to complete the first two questions in their group, and then gather additional information from two other groups (who measured *different* objects) for the third question.

If using the digital activity, students can work in groups of 2–4. They only need the applet to generate data for their investigation.

Support for Students with Disabilities

Action and Expression: Internalize Executive Functions. Chunk this task into more manageable parts to support students who benefit from support with organization and problem solving. Check in with students after they have measured their first circular object to ensure they have a viable method for measuring circumference.

Supports accessibility for: Organization; Attention

Anticipated Misconceptions

Students may try to measure the diameter without going across the widest part of the circle, or may struggle with measuring around the circumference. Mentally check that their measurements divide to get approximately 3 or compare with your own prepared table of data and prompt them to re-measure when their measurements are off by too much. If the circular object has a rim or lip, this could help students keep the measuring tape in place while measuring the circumference.

If students are struggling to see the proportional relationship, remind them of recent examples where they have seen similar graphs of proportional relationships. Ask them to estimate additional diameter-circumference pairs that would fit the pattern shown in the graph. Based on their graphs, do the values of the circumferences seem to relate to those of the diameters in a particular way? What seems to be that relationship?

Student Task Statement

Your teacher will give you several circular objects.

1. Measure the diameter and the circumference of the circle in each object to the nearest tenth of a centimeter. Record your measurements in the table.

object	diameter (cm)	circumference (cm)

2. Plot the diameter and circumference values from the table on the coordinate plane. What do you notice?

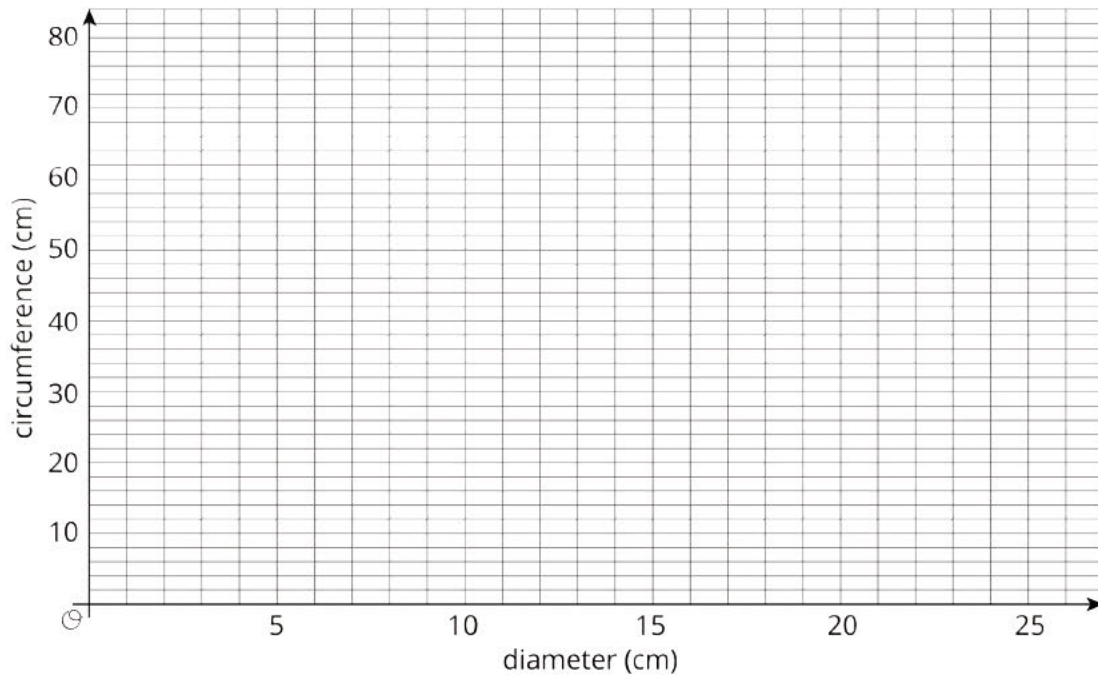

3. Plot the points from two other groups on the same coordinate plane. Do you see the same pattern that you noticed earlier?

Student Response

1. Answers vary. Sample response:

object	diameter (cm)	circumference (cm)
soup can	6.8	21.5
tomato paste can	5.4	17
tuna can	8.5	26.5

2. Answers vary. Sample response: Three of the points on the following graph.

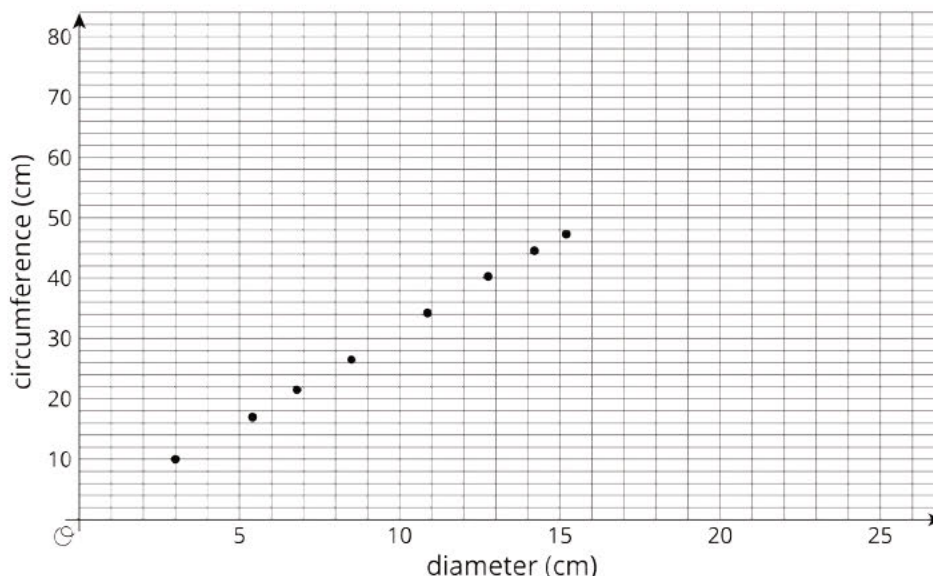

The points look like they are close to lying on a straight line through $(0, 0)$.

3. Answers vary. Sample response: Six more points on the previous graph.

Activity Synthesis

Display a graph for all to see, and plot some of the students' measurements for diameter and circumference. In cases where the same object was measured by multiple groups, include only one measurement per object. Ask students to share what they notice and what they wonder about the graph.

- Students may notice that the measurements appear to lie on a line (or are close to lying on a line) that goes through $(0, 0)$. If students do not mention a proportional relationship, make this explicit.
- Students may wonder why some points are not on the line or what the constant of proportionality is.

Invite students to estimate the constant of proportionality. From the graph, it may be difficult to make a better estimate than about 3. Another strategy is to add a column to the table, and compute the quotient of the circumference divided by the diameter for each row. For example,

object	diameter (cm)	circumference (cm)	circumference \div diameter
soup can	6.8	21.5	3.2
tomato paste can	5.4	17	3.1
tuna can	8.5	26.5	3.1

Ask students why these numbers might not be *exactly* the same (measurement error, rounding). Use the average of the quotients, rounded to one or two decimal places, to come up with a “working value” of the constant of proportionality: for the numbers in the sample table above, 3.1 would be an appropriate value. This class-generated proportionality constant will be used in the next activity, to help students understand how to compute circumference from diameter and vice versa. There’s no need to mention π or its usual approximations yet.

Time permitting, it could be worth discussing accuracy of measurements for circumference and diameter. Measuring the diameter to the nearest tenth of a centimeter can be done pretty reliably with a ruler. Measuring the circumference of a circle to the nearest tenth of a centimeter may or may not be reliable, depending on the method used. Wrapping a flexible measuring tape around the object is likely the most accurate method for measuring the circumference of a circle.

Support for English Language Learners

Representing, Conversing: MLR7 Compare and Connect. After measuring their circular objects and recording the data, students should be prepared to share their written or digital graphs and tables. Ask students to tour each other’s displays with their group, and say, “As you tour the room, look for graphs/tables with familiar patterns or relationships. Discuss with your group what you can conclude and select one person record what you notice as you go.” Circulate and amplify any conversation involving recurring patterns of “around 3” or “a little more than 3.” Complete the task with a class discussion, asking each group share out what they found that was similar or relationships they saw in numbers or plotted points.

Design Principle(s): Cultivate conversation; Maximize meta-awareness

3.3 Calculating Circumference and Diameter

10 minutes

In this task, students use the constant of proportionality they estimated in the previous task to calculate circumferences of circles given the diameter and vice versa. The purpose is to reinforce the proportional relationship between circumference c and diameter d and use the formula $c = kd$, where k is about 3 or 3.1 (the value agreed upon in the previous task).

If there is not sufficient time to allow students to work through all of the calculations, consider dividing up the work, assigning one circle to each student or group of students. It is important to save enough time for the discussion about the meaning and value of π at the end of this activity.

Before students begin the task, a digital applet found at <http://ggbm.at/H8UuD96V> can be used to reinforce the constant of proportionality.

Addressing

- 7.G.B.4
- 7.RP.A.2

Launch

Ask students to label these measurements given in the table on the picture of the circles. Instruct students to use the constant of proportionality the class estimated in the previous activity. Give students quiet work time followed by whole-class discussion.

Anticipated Misconceptions

Some students may multiply the circumference by the constant of proportionality instead of dividing by it. Prompt them to consider whether the diameter can be longer than the circumference of a circle.

Some students may struggle to divide by 3.1 if that is the constant of proportionality decided on in the previous lesson. Ask these students if they could use an easier number as their constant, and allow them to divide by 3 instead. Then ask them how their answer would have changed if they divided by 3.1.

Student Task Statement

Here are five circles. One measurement for each circle is given in the table.

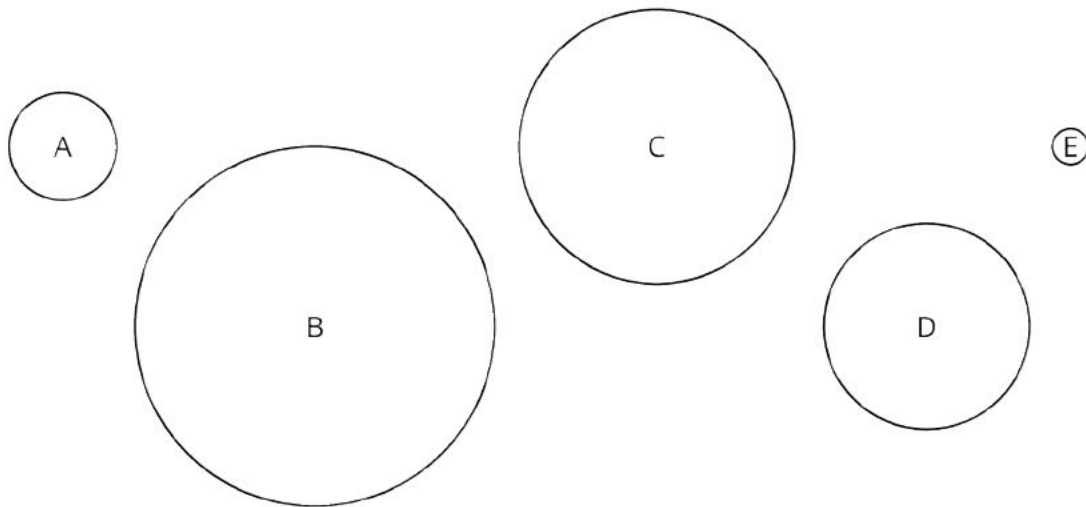

Use the constant of proportionality estimated in the previous activity to complete the table.

	diameter (cm)	circumference (cm)
circle A	3	
circle B	10	
circle C		24
circle D		18
circle E	1	

Student Response

Answers vary. Sample response using 3.1 for the constant of proportionality

	diameter (cm)	circumference (cm)
circle A	3	9.3
circle B	10	31
circle C	7.7	24
circle D	5.8	18
circle E	1	3.1

Are You Ready for More?

The circumference of Earth is approximately 40,000 km. If you made a circle of wire around the globe, that is only 10 meters (0.01 km) longer than the circumference of the globe, could a flea, a mouse, or even a person creep under it?

Student Response

Yes! Each meter added to the diameter of a circle adds about 3.1 meters to the circumference of the circle. So if the circumference of Earth is increased by 10 meters, this means that a little more than 3 meters have been added to the diameter. So there would be about 1.5 meters of distance between the rope and Earth, making it easy for a flea, mouse, or person to go under the rope!

Activity Synthesis

Display the table from the task statement for all to see. Ask students to share their answers and write these in the table, resolving any discrepancies.

Ask students if they noticed any connections between the tables and the graphs from the previous activity. Students will have used the equation $C = kd$, possibly without realizing it, to fill in the missing information so it is important for them to make this connection. To reinforce this connection, add the points from the table they just completed to the graph from the previous activity. Point out that the constant of proportionality appears in the table as the unit rate in the row with diameter 1 cm.

Ask if students have heard of the number **pi** or seen the symbol π . Define π as the exact value of the constant of proportionality for this relationship. Explain that the exact value of π is a decimal with infinitely many digits and no repeating pattern, so an approximation is often used. Frequently used approximations for π include $\frac{22}{7}$, 3.14, and 3.14159, but none of these are exactly equal to π .

Lesson Synthesis

The main ideas are:

- Diameter and circumference are proportional to each other.
- We can find one from the other using the relationship $C = kd$, where k is the proportionality constant, which we have estimated as 3.1 (average from task “Measuring Circumference and Diameter”). For example, for a circle of diameter 4 cm, we have $3.1 \cdot 4 \approx 12.4$, so the circle has a circumference approximately equal to 12.4 cm.
- The exact constant of proportionality is called π . Frequently used approximations for π are $\frac{22}{7}$, 3.14, and 3.14159, but none of these are exactly π .

3.4 Identifying Circumference and Diameter

Cool Down: 5 minutes

Addressing

- 7.G.B.4

Student Task Statement

Select **all** the pairs that could be reasonable approximations for the diameter and circumference of a circle. Explain your reasoning.

1. 5 meters and 22 meters.
2. 19 inches and 60 inches.
3. 33 centimeters and 80 centimeters.

Student Response

Only B could be the diameter and circumference of a circle, because the quotient is a little more than 3. The others are too far off to be correct.

1. Does not work, because $22 \div 5 > 4$.

2. Does work, because $60 \div 19 \approx 3.158$.
3. Does not work, because $80 \div 33 < 2.5$.

Student Lesson Summary

There is a proportional relationship between the diameter and circumference of any circle. That means that if we write C for circumference and d for diameter, we know that $C = kd$, where k is the constant of proportionality.

The exact value for the constant of proportionality is called π . Some frequently used approximations for π are $\frac{22}{7}$, 3.14, and 3.14159, but none of these is exactly π .

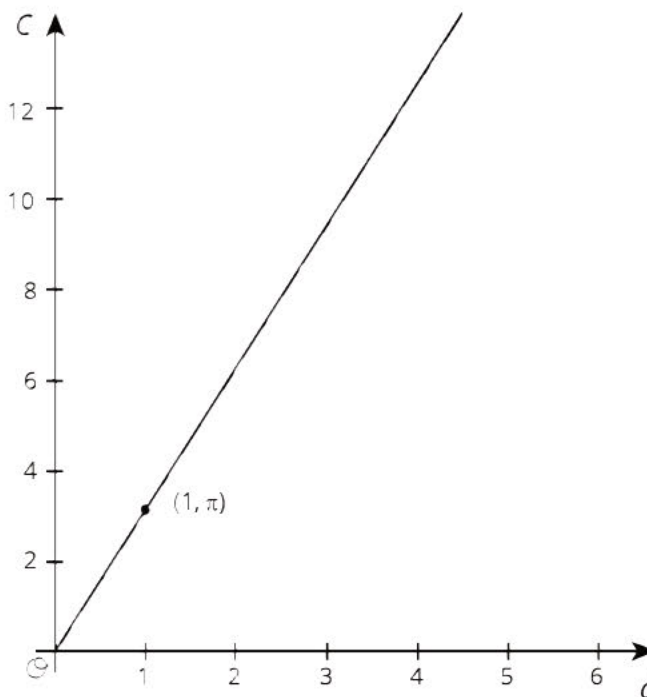

We can use this to estimate the circumference if we know the diameter, and vice versa. For example, using 3.1 as an approximation for π , if a circle has a diameter of 4 cm, then the circumference is about $(3.1) \cdot 4 = 12.4$ or 12.4 cm.

The relationship between the circumference and the diameter can be written as

$$C = \pi d$$

Glossary

- pi (π)

Lesson 3 Practice Problems

Problem 1

Statement

Diego measured the diameter and circumference of several circular objects and recorded his measurements in the table.

object	diameter (cm)	circumference (cm)
half dollar coin	3	10
flying disc	23	28
jar lid	8	25
flower pot	15	48

One of his measurements is inaccurate. Which measurement is it? Explain how you know.

Solution

The measurement for the flying disc is very inaccurate. It should be about 3 times the diameter (or a little more).

Problem 2

Statement

Complete the table. Use one of the approximate values for π discussed in class (for example 3.14, $\frac{22}{7}$, 3.1416). Explain or show your reasoning.

object	diameter	circumference
hula hoop	35 in	
circular pond		556 ft
magnifying glass	5.2 cm	
car tire		71.6 in

Solution

object	diameter	circumference
hula hoop	35 in	110 in
circular pond	177 ft	556 ft
magnifying glass	5.2 cm	16 cm
car tire	22.8 in	71.6 in

The constant of proportionality is about 3.14. The given diameters are multiplied by 3.14 to find the missing circumferences. The given circumferences are divided by 3.14 to find the missing diameters. Both the missing circumferences and the missing diameters have been rounded.

Problem 3

Statement

A is the center of the circle, and the length of CD is 15 centimeters.

- Name a segment that is a radius. How long is it?
- Name a segment that is a diameter. How long is it?

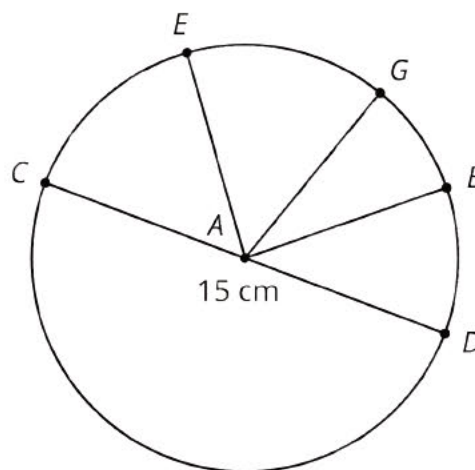

Solution

- Answers vary. Sample responses: AC , AD , AB , AE , AG , 7.5 cm
- CD , 15 cm

(From Unit 3, Lesson 2.)

Problem 4

Statement

- Consider the equation $y = 1.5x + 2$. Find four pairs of x and y values that make the equation true. Plot the points (x, y) on the coordinate plane.

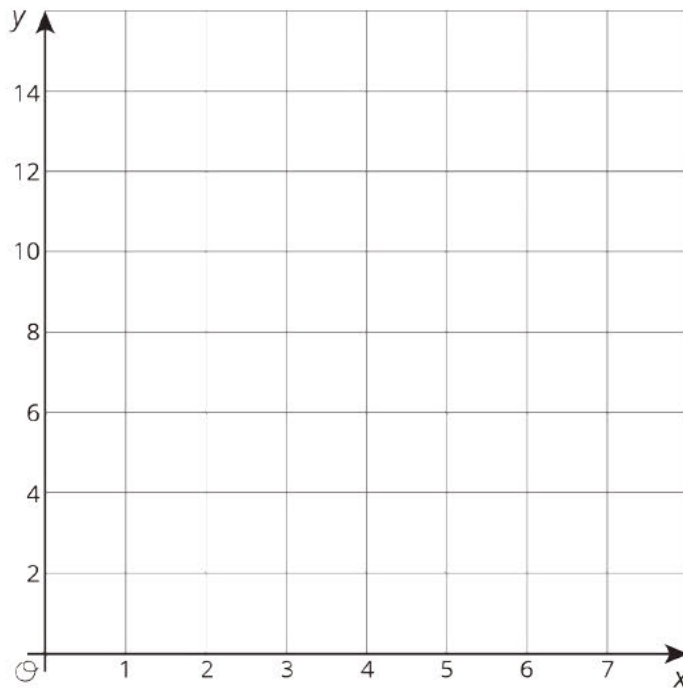

b. Based on the graph, can this be a proportional relationship? Why or why not?

Solution

a. Answers vary. Sample response:

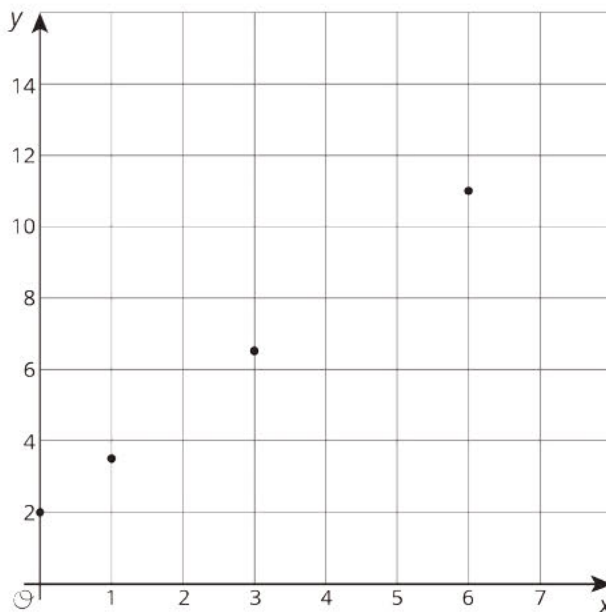

b. Answers vary. Sample response: No, this relationship could not be proportional because the graph does not go through $(0, 0)$.

(From Unit 2, Lesson 10.)

Lesson 4: Applying Circumference

Goals

- Apply understanding of circumference to calculate the perimeter of a shape that includes circular parts, and explain (orally and in writing) the solution method.
- Compare and contrast (orally) values for the same measurements that were calculated using different approximations for π .
- Explain (orally) how to calculate the radius, diameter, or circumference of a circle, given one of these three measurements.

Learning Targets

- I can choose an approximation for π based on the situation or problem.
- If I know the radius, diameter, or circumference of a circle, I can find the other two.

Lesson Narrative

In this lesson, students use the equation $C = \pi d$ to solve problems in a variety of contexts. They compute the circumference of circles and parts of circles given diameter or radius, and vice versa. Students develop flexibility using the relationships between diameter, radius, and circumference rather than memorizing a variety of formulas. Understanding the equation $C = 2\pi r$ will help with the transition to the study of area in future lessons.

Students think strategically about how to decompose and recompose complex shapes (MP7) and need to choose an appropriate level of precision for π and for their final calculations (MP6).

Alignments

Addressing

- 7.G.B.4: Know the formulas for the area and circumference of a circle and use them to solve problems; give an informal derivation of the relationship between the circumference and area of a circle.

Instructional Routines

- Anticipate, Monitor, Select, Sequence, Connect
- MLR2: Collect and Display
- MLR5: Co-Craft Questions
- MLR7: Compare and Connect
- MLR8: Discussion Supports
- Notice and Wonder

- Think Pair Share

Required Materials

Four-function calculators

Student Learning Goals

Let's use π to solve problems.

4.1 What Do We Know? What Can We Estimate?

Warm Up: 5 minutes

The purpose of this warm-up is for students to reason about the various measurements of a circle. In each of the pictures, students are given a piece of information about the circle and asked to reason about the other measurements of the circle. Some of these measurements can be found based on the given information while others, without a calculator, would require an estimate.

Addressing

- 7.G.B.4

Instructional Routines

- MLR2: Collect and Display
- Think Pair Share

Launch

Arrange students in groups of 2. Give students 1 minute of quiet think time followed by 2 minutes to discuss their estimates with a partner.

Student Task Statement

Here are some pictures of circular objects, with measurement tools shown. The measurement tool on each picture reads as follows:

- Wagon wheel: 3 feet
- Plane propeller: 24 inches
- Sliced Orange: 20 centimeters



1. For each picture, which measurement is shown?
2. Based on this information, what measurement(s) could you estimate for each picture?

Student Response

1.
 - For the wagon wheel, the measurement of the diameter is shown.
 - For the plane propeller, the measurement of the radius is shown.
 - For the sliced orange, the circumference is shown.
2.
 - For the wagon wheel, I could estimate the circumference.
 - For the plane propeller, I could estimate the circumference.
 - For the sliced orange, I could estimate the diameter and the radius.

Activity Synthesis

For each picture, ask selected students to share the measurements shown in the pictures. Ask students to explain the strategies or calculations they would use for computing or estimating other measurements (for example, the radius and circumference of the wheel). Record and display student responses on the actual pictures. Refer to MLR 2 (Collect and Display) to highlight student responses and language about what they know and what they estimated.

4.2 Using π

10 minutes (there is a digital version of this activity)

In the previous lesson, students identified the constant of proportionality relating the circumference and diameter of a circle. The purpose of this activity is for students to calculate measurements of a circle using different approximations of π . Students are given either the radius, diameter, or circumference of a circle and use calculators to compute the other two measurements. Different students use different approximations of π : $\frac{22}{7}$, 3.14, and 3.1415927. The last approximation for π is the precision that many calculators show.

The different approximations for π lead to different estimates for the missing measurements, and they should be encouraged to think about which approximation is the most useful in these cases.

Addressing

- 7.G.B.4

Instructional Routines

- MLR7: Compare and Connect

Launch

Divide students into 3 groups. Assign each group a different approximation for π to use in their calculations: 3.1415927, 3.14, and $\frac{22}{7}$. Give students 4–5 minutes of quiet work time followed by whole-class discussion.

If using the digital activity, students can work in small groups to complete the task. The applet demonstrates the relationship between rotation and circumference.

Support for Students with Disabilities

Action and Expression: Internalize Executive Functions. Chunk this task into more manageable parts to support students who benefit from support with organizational skills in problem solving. For example, after students have completed the first 1–2 rows of the table, check for understanding before moving on.

Supports accessibility for: Organization; Attention

Student Task Statement

In the previous activity, we looked at pictures of circular objects. One measurement for each object is listed in the table.

Your teacher will assign you an approximation of π to use for this activity.

1. Complete the table.

object	radius	diameter	circumference
wagon wheel		3 ft	
airplane propeller	24 in		
orange slice			20 cm

2. A bug was sitting on the tip of the propeller blade when the propeller started to rotate. The bug held on for 5 rotations before flying away. How far did the bug travel before it flew off?

Student Response

1.

object	radius	diameter	circumference
wagon wheel	1.5 ft	3 ft	9.4247781 ft 9.42 ft $9\frac{3}{7}$ ft
airplane propeller	24 in	48 in	150.7964496 in 150.72 in $150\frac{6}{7}$ in
orange slice	3.183098815 cm 3.184713376 cm $3\frac{2}{11}$ cm	6.36619763 cm 6.36942675 cm $6\frac{4}{11}$ cm	20 cm

2. The bug travels about 754 inches, because $(150.7964496) \cdot 5 = 753.982248$.

Activity Synthesis

Compare the measurements that students calculated using the different approximations of π . Point out that while the approximation for π influences the values of the radius and diameter, it does not affect the relationship $d = 2 \cdot r$. Use the circumference of the wagon wheel to point out that all three results (9.4285714 ft, 9.42 ft, and 9.4247781 ft) agree in the first three digits, i.e., to within a hundredth of a foot. Explain that even when using 3.1415927, the measurements are still approximations.

Discuss whether 9.4247781 ft for the circumference of a wagon wheel or 3.183098815 cm for the radius of an orange slice is a reasonable number of decimal places to report the measurement. Could these objects actually be measured that precisely? Explain that people use different approximations for π depending on the situation and the precision of the measurement. For situations like these where the measurements themselves do not have too much accuracy either 3.14 or $\frac{22}{7}$ is probably the most appropriate value of π to use. Using a more accurate value for π is always acceptable, but the final answer should not be reported with more accuracy than the measurements.

When working with circles, sometimes it is more natural to work with the diameter and sometimes with the radius. But we can always go quickly from one to the other, if needed. Emphasize the progression in solving the propeller problem: use the radius to get the diameter, then the diameter to get the circumference. It is not necessary for students to learn the rule $C = 2\pi r$, but this would be the place to do so if desired.

Support for English Language Learners

Speaking, Writing: MLR7 Compare and Connect. As students complete their calculations in small groups, ask them to leave their work out on display. Ask students to do a gallery walk around the room to examine the work of their peers, and consider why, specifically, each approximation for π did or did not produce a different result. Ask students, “How does (this) response compare with your team’s?” “What do the answers have in common?” (For example, up to what decimal place.) This routine will help students to focus the discussion on why one approximation did or did not produce a different result.

Design Principle(s): Support sense-making; Cultivate conversation

4.3 Around the Running Track

Optional: 15 minutes

In this activity, students compute the length of a figure that is composed of half-circles and straight line segments. For the first question, they are given the length of the line segments and the diameter of the circle. For the second question, students have to compute the diameter of the circle.

As students work, monitor for students who decomposed the figure in different ways and used different approximations of π . The discussion focuses on whether the differences lead to meaningful differences in the estimate for the distance around the track.

Addressing

- 7.G.B.4

Instructional Routines

- MLR5: Co-Craft Questions
- Think Pair Share

Launch

If desired, introduce the context of a running track. Allow students to choose what approximation to use for π . Quiet work time followed by partner discussion.

Support for Students with Disabilities

Action and Expression: Internalize Executive Functions. Provide students with a graphic organizer to organize the information provided in the problem and to structure their problem-solving strategy. The graphic organizer should include the prompts: “What do I need to find out?”, “What do I need to do?”, and “How I solved the problem.”

Supports accessibility for: Language; Organization

Support for English Language Learners

Speaking, Writing: MLR5 Co-Craft Questions. To help students understand the situation, display the image of the running track, and ask students to write down possible mathematical questions they could ask. Listen for, and amplify language students use to describe different parts of the track (inside and outside), half-circles, straight line segments, etc. Then, invite pairs to share their questions with the class. This will help students produce the language of mathematical questions, and support common understanding of the situation.

Design Principle(s): Maximize meta-awareness; Support sense-making

Anticipated Misconceptions

If students have trouble seeing the circle and rectangle that compose the figure, suggest that they draw additional lines to decompose the figure.

Students might apply the formula for the circumference of a circle to find the circumference of the oval-shaped field and track. If this happens, remind students that the track is not in the shape of a circle. Ask if they see a way to form a circle and a rectangle within the space.

Students who are familiar with the fact that this size track is referred to as a 400-meter track may be confused when their answer does not equal 400 meters. Explain that a runner does not run right on the edge of the track and possibly direct the student to look at the extension.

Student Task Statement

The field inside a running track is made up of a rectangle that is 84.39 m long and 73 m wide, together with a half-circle at each end.

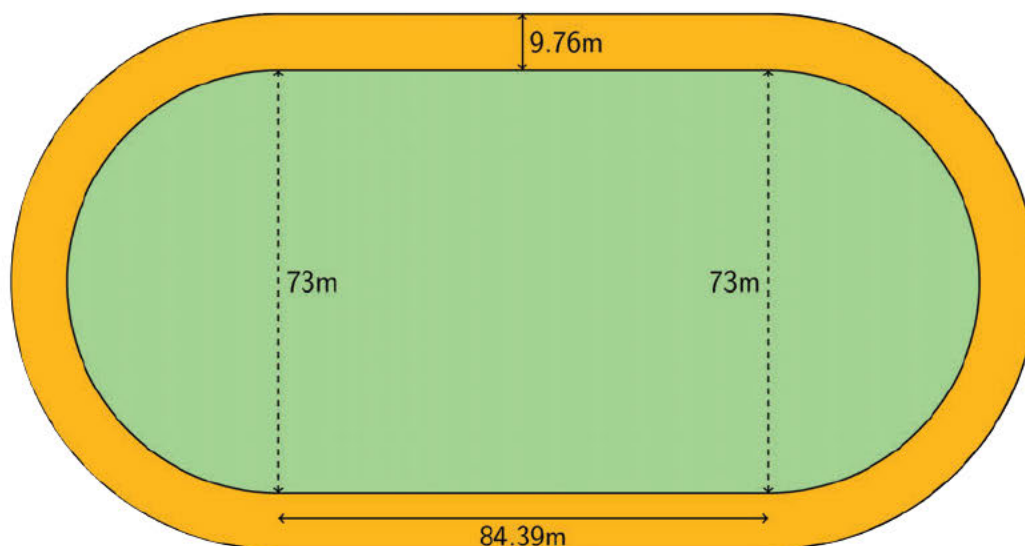

1. What is the distance around the inside of the track? Explain or show your reasoning.
2. The track is 9.76 m wide all the way around. What is the distance around the outside of the track? Explain or show your reasoning.

Student Response

1. The inside of the track is 398 m long. The distance around each half-circle is 114.61 m, because $73 \cdot 3.14 \div 2 = 114.61$. Add two line segments and two half-circles:
 $84.39 + 84.39 + 114.61 + 114.61 = 398$.
2. The outside of the track is 459.3 m long. The diameter of the larger half-circles is 92.52 m, because $73 + 9.76 + 9.76 = 92.52$. The distance around the large half-circle is 145.26 m, because $92.52 \cdot 3.14 \div 2 = 145.26$. Add two line segments and two half-circles:
 $84.39 + 84.39 + 145.26 + 145.26 = 459.3$.

Are You Ready for More?

This size running track is usually called a 400-meter track. However, if a person ran as close to the “inside” as possible on the track, they would run less than 400 meters in one lap. How far away from the inside border would someone have to run to make one lap equal exactly 400 meters?

Student Response

The length of the straight part of the track is not affected by the distance from the border that a person runs. Excluding the straight parts, the rest of the distance is 231.22 meters, because $400 - 2 \cdot 84.39 = 231.22$. The half-circles must have a diameter of 73.6 meters, because $231.22 \div \pi \approx 73.6$. The runner must run 0.3 meters in from the inside border of the track, because $(73.6 - 73) \div 2 = 0.3$.

Activity Synthesis

Most of the discussion will occur in small groups. However, the whole class can debrief on the following questions:

- “In what ways did you decompose the figure into different shapes?”
- “Why did you choose a particular approximation for π , and what was the resulting answer?”
- “How are different students’ answers related, and are they all reasonable lengths for this situation?”

Students who use more digits for their approximation of π may come up with a slightly different answer, such as 398.1. In general, when making calculations, if only an estimate is desired, then using 3.14 for π is usually good enough. In a situation like this, where the given measurements are quite precise, it can be worth trying more digits in the expansion of π , but it turns out not to make much difference in this case.

4.4 Measuring a Picture Frame

10 minutes

The purpose of this activity is to calculate the length of a complex shape made out of parts of circles. Students are given a drawing of a picture frame that is made up of half-circles and three-quarter circles and are asked to find the total length required to make the frame out of wire. Next, students are asked what the radius would be of a circle with a circumference equal to the picture frame’s perimeter. This activity marks the first time that the term *perimeter* is used in the context of circumference.

As students work, monitor and select students who approach the problem differently to share their solution methods in the discussion. There are many different methods to calculate the perimeter of the wire that show different ways of thinking about the circles and combining them (MP7): 10 full circles, 7 full circles from the half-circles and 3 full circles from the $\frac{3}{4}$ circles, 18 separate parts of circles.

Addressing

- 7.G.B.4

Instructional Routines

- Anticipate, Monitor, Select, Sequence, Connect
- MLR8: Discussion Supports
- Notice and Wonder

Launch

Display the image from the task statement and ask students to share what they notice and what they wonder. Confirm that the shapes are half-circles and $\frac{3}{4}$ of a circle in each corner. Also, tell them that all of these circles are the same size.

Give students quiet work time followed by whole-class discussion.

Support for Students with Disabilities

Action and Expression: Internalize Executive Functions. Chunk this task into more manageable parts to support students who benefit from support with organization and problem solving. For example, break the first question into multiple parts. First, ask students to calculate the perimeter of the half circles on each side of the picture frame. Next, ask students to calculate the perimeter of the three-quarter circles at each corner of the picture frame. Lastly, ask students to calculate the total perimeter of the wire around the picture frame.

Supports accessibility for: Organization; Attention

Support for English Language Learners

Reading, Conversing: MLR8 Discussion Supports. Ask students to describe how the wire picture frame and rectangle are arranged. Students should work with a partner and take turns speaking/listening. Tell students, "Show your partner the shapes you notice in the picture. Draw the shapes in the air, explaining to your partner what shapes you see." Point out that the rectangle's measurements are listed. Say, "Explain to your partner how you can use the measurements listed with the shapes you see. How are the corner circles different?" This should help students focus in on the formulas they want to use to solve and how to justify their reasons for their choices.

Design Principle(s): Support sense-making; Maximize meta-awareness

Anticipated Misconceptions

Some students may not have realized the connection between circumference and perimeter and will need to be prompted to use the circumference of the circular pieces to find the perimeter of the wire frame.

Students might try to include the perimeter of the rectangle when calculating the perimeter of the wire frame. Explain that we are only looking for the length of all the circular pieces.

Once they have figured out the size of each half-circle's diameter, it might be challenging for some students to imagine the frame being stretched to form one complete circle. Suggest that the entire length of the frame becomes the circumference of the complete circle. It might be helpful to have

some string and an index card available for students to explore the idea of bending and stretching the frame.

Student Task Statement

Kiran bent some wire around a rectangle to make a picture frame. The rectangle is 8 inches by 10 inches.

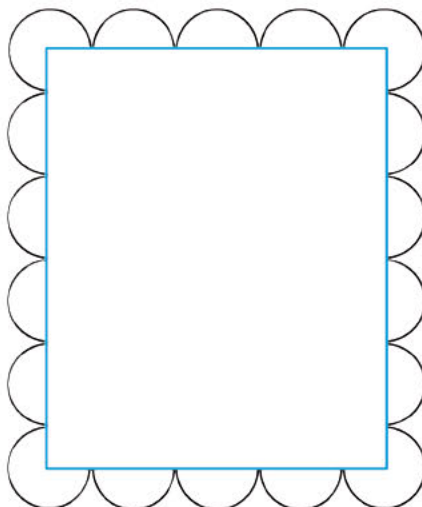

1. Find the perimeter of the wire picture frame. Explain or show your reasoning.
2. If the wire picture frame were stretched out to make one complete circle, what would its radius be?

Student Response

1. Each half-circle has a diameter of 2 inches, because $8 \div 4 = 2$. Each half-circle has a length of about 3.14 inches, because $2 \cdot \pi \div 2 \approx 3.14$. Each three-quarters circle has a length of about 4.71 inches, because $2 \cdot \pi \cdot 0.75 \approx 4.71$. The frame's perimeter is about 62.8 inches, because it has 14 half-circles and 4 three-quarters circles, and $14\pi + 4.71 \cdot 4 \approx 62.8$.
2. The radius of the circle made out of the frame would be about 10 inches, because $62.8 \div \pi \div 2 \approx 10$.

Activity Synthesis

Ask the students how they used the dimensions of the picture frame to find the radii of the circles. The long side, for example, is made up of 4 diameters and 2 radii of circles. That is the same as 10 radii so if that side measures 10 inches, then the radius of the circle is 1 inch.

Ask select students to share different ways they decomposed the wire frame into parts. Possible methods include:

- 14 half-circles + 4 three-quarter circles
- 7 full circles + 4 three-quarter circles

- 7 full circles + 3 full circles
- 10 full circles

Ask students to discuss how they used the circumference of the circle in their work. If it does not arise in discussing the second question, make explicit the idea that knowing the circumference of the circle allows you to work backwards to find the circle's radius.

Lesson Synthesis

The main ideas are:

- The proportional relationship between diameter and circumference of a circle can be applied in more complex situations that require multi-step solutions.
- Because the diameter is twice the radius, we can write the relationship between the circumference of a circle and its radius like this: $C = 2\pi r$.

Discussion questions:

- What are some approximations of π ?
- If I know the radius of a circle, how do I find its diameter and circumference?
- What if I know the circumference? How do I find diameter or radius?

4.5 Circumferences of Two Circles

Cool Down: 5 minutes

Addressing

- 7.G.B.4

Anticipated Misconceptions

Some students may not notice that the radius was given for Circle B rather than the diameter. They will likely answer the first question incorrectly, but they may still get the correct answer of about 9.42 cm for the second question, because $12 - 9 = 3$ and also $9 - 6 = 3$.

Student Task Statement

Circle A has a diameter of 9 cm. Circle B has a radius of 5 cm.

1. Which circle has the larger circumference?
2. About how many centimeters larger is it?

Student Response

1. Circle B has the larger circumference. Circle A has a diameter of 9 cm, and Circle B has a diameter of $5 \cdot 2$, or 10 cm. Since Circle B's diameter is larger than Circle A's diameter, and circumference is proportional to diameter, that means Circle B's circumference is also larger.

2. The difference is about 3.14 cm because the circumference of Circle A is 9π , or about 28.26 cm, and the circumference of Circle B is 10π , or about 31.4 cm. The difference is $31.4 - 28.26$, or about 3.14 cm.

Student Lesson Summary

The circumference of a circle, C , is π times the diameter, d . The diameter is twice the radius, r . So if we know any one of these measurements for a particular circle, we can find the others. We can write the relationships between these different measures using equations:

$$\begin{aligned}d &= 2r \\C &= \pi d \\C &= 2\pi r\end{aligned}$$

If the diameter of a car tire is 60 cm, that means the radius is 30 cm and the circumference is $60 \cdot \pi$ or about 188 cm.

If the radius of a clock is 5 in, that means the diameter is 10 in, and the circumference is $10 \cdot \pi$ or about 31 in.

If a ring has a circumference of 44 mm, that means the diameter is $44 \div \pi$, which is about 14 mm, and the radius is about 7 mm.

Lesson 4 Practice Problems

Problem 1

Statement

Here is a picture of a Ferris wheel. It has a diameter of 80 meters.



- On the picture, draw and label a diameter.
- How far does a rider travel in one complete rotation around the Ferris wheel?

Solution

- Answers vary. Possible response:



- b. In one complete rotation, a rider travels the circumference of the Ferris wheel. This distance is $80 \cdot \pi$, or about 251 meters. Since the gondola where the rider is seated is a little bit further from the center of the Ferris wheel than 40 meters, the distance the rider travels is actually a little more.

Problem 2

Statement

Identify each measurement as the diameter, radius, or circumference of the circular object. Then, estimate the other two measurements for the circle.

- The length of the minute hand on a clock is 5 in.
- The distance across a sink drain is 3.8 cm.
- The tires on a mining truck are 14 ft tall.
- The fence around a circular pool is 75 ft long.
- The distance from the tip of a slice of pizza to the crust is 7 in.
- Breaking a cookie in half creates a straight side 10 cm long.
- The length of the metal rim around a glass lens is 190 mm.
- From the center to the edge of a DVD measures 60 mm.

Solution

- Radius; diameter: 10 in, circumference: about 31 in
- Diameter; radius: 1.9 cm, circumference: about 12 cm
- Diameter; radius: 7 ft, circumference: about 44 ft

- d. Circumference; diameter: about 24 ft, radius: about 12 ft
- e. Radius; diameter: 14 in, circumference: about 44 in
- f. Diameter; radius: 5 cm, circumference: about 31 cm
- g. Circumference; diameter: about 60 mm, radius: about 30 mm
- h. Radius; diameter: 120 mm, circumference: about 380 mm

Problem 3

Statement

A half circle is joined to an equilateral triangle with side lengths of 12 units. What is the perimeter of the resulting shape?

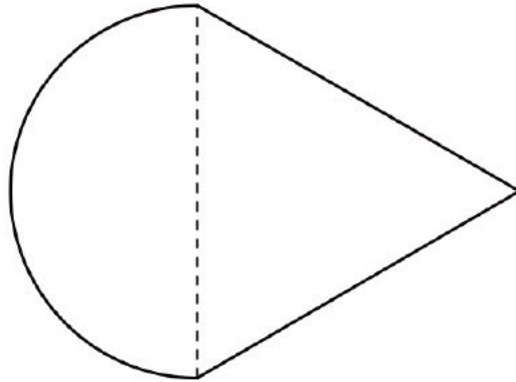

Solution

about 42.84 units. The two sides of the triangle each contribute 12 units and the semi-circle has a perimeter of $6 \cdot \pi$ or about 18.84 units.

Problem 4

Statement

Circle A has a diameter of 1 foot. Circle B has a circumference of 1 meter. Which circle is bigger? Explain your reasoning. (1 inch = 2.54 centimeters)

Solution

Circle B is bigger. Answers vary. Possible explanation: There are 12 inches in 1 foot. The circumference of Circle A is about 95.8 cm because $1 \cdot 12 \cdot 2.54 \cdot \pi \approx 95.8$. The circumference of Circle B is 100 cm because there are 100 cm in 1 m.

Problem 5

Statement

The circumference of Tyler's bike tire is 72 inches. What is the diameter of the tire?

Solution

$72 \div \pi$ or about 23 inches.

(From Unit 3, Lesson 3.)

Lesson 5: Circumference and Wheels

Goals

- Compare wheels of different sizes and explain (orally) why a larger wheel needs fewer rotations to travel the same distance.
- Generalize that the distance a wheel rolls in one rotation is equal to the circumference of the wheel.
- Write an equation to represent the proportional relationship between the number of rotations and the distance a wheel travels.

Learning Targets

- If I know the radius or diameter of a wheel, I can find the distance the wheel travels in some number of revolutions.

Lesson Narrative

This lesson is optional. The goal of this lesson is to apply students' understanding of circumference to calculate how far a wheel travels when it rolls a certain number of times. This relationship is vital for how odometers and speedometers work in vehicles.

In previous lessons, students saw that the relationships between radius, diameter, and circumference of different circles are proportional relationships. In this lesson, they notice that the circumference of a circle is the same as the distance a wheel rolls forward as it completes one rotation. Next, they see that there is also a proportional relationship between the number of times a wheel rotates and the distance the wheel travels. The last activity examines the relationship between the speed a vehicle is traveling and the number of rotations of the tires in a given amount of time.

Students make use of the structure of a proportional relationship as they work toward describing the relationship between the number of rotations of a wheel and the distance the wheel travels with an equation (MP7).

Alignments

Addressing

- 7.G.B.4: Know the formulas for the area and circumference of a circle and use them to solve problems; give an informal derivation of the relationship between the circumference and area of a circle.
- 7.RP.A.2.a: Decide whether two quantities are in a proportional relationship, e.g., by testing for equivalent ratios in a table or graphing on a coordinate plane and observing whether the graph is a straight line through the origin.

- 7.RP.A.2.c: Represent proportional relationships by equations. For example, if total cost t is proportional to the number n of items purchased at a constant price p , the relationship between the total cost and the number of items can be expressed as $t = pn$.
- 7.RP.A.3: Use proportional relationships to solve multistep ratio and percent problems. Examples: simple interest, tax, markups and markdowns, gratuities and commissions, fees, percent increase and decrease, percent error.

Instructional Routines

- MLR5: Co-Craft Questions
- MLR7: Compare and Connect
- MLR8: Discussion Supports
- Think Pair Share

Required Materials

Blank paper

Cylindrical household items

Receipt tape

Rulers

Required Preparation

You can reuse the same cylindrical household items from a previous lesson. Again, each group needs 3 items of relatively different sizes; however, it is not as important to include a wide variety of sizes. Because of the restrictions of paper size, you may want to forego using the larger objects (such as the paper plate) in this activity.

Prepare to distribute blank paper that is long enough for students to trace one complete rotation of their cylindrical object. For objects with a diameter greater than 4 inches, receipt tape may be better.

Student Learning Goals

Let's explore how far different wheels roll.

5.1 A Rope and a Wheel

Warm Up: 5 minutes

This warm-up reminds students of the meaning and rough value of π . They apply this reasoning to a wheel and will continue to study wheels throughout this lesson. Students critique the reasoning of others (MP3).

Addressing

- 7.G.B.4

Launch

Give students 1 minute of quiet think time, 1 minute to discuss in small groups, then group discussion.

Student Task Statement

Han says that you can wrap a 5-foot rope around a wheel with a 2-foot diameter because $\frac{5}{2}$ is less than pi. Do you agree with Han? Explain your reasoning.

Student Response

Han is not correct. The circumference of the wheel is 2π feet. Since π is a little bit larger than 3, this is more than 6 feet, and the 5-foot rope will not fit all the way around.

Activity Synthesis

Ask students to share their reasoning emphasizing several important issues:

- The circumference of the wheel is 2π feet.
- π is larger than 3 (about 3.14) so the circumference of this wheel is more than 6 feet.
- Han is right that $\frac{5}{2} < \pi$, but this means that the rope will not make it all the way around.

Ask students if a 6-foot rope would be long enough to go around the wheel (no because $\frac{6}{2}$ is still less than π). What about a 7-foot rope? (Yes, because the circumference of the wheel is 2π feet and this is less than 7.)

Students may observe that it is possible to wrap the rope around the wheel going around a diameter twice as opposed to going around the circumference.

5.2 Rolling, Rolling, Rolling

Optional: 15 minutes

Students measure the circumference of circles by rolling them like wheels. They relate this to what they previously learned about the relationship between the diameter of a circle and its circumference. The circular objects that students measured earlier can be reused for this activity, the difference being that rather than wrapping something around each circle, they will roll the circle on a flat surface in order to measure its circumference. If reusing the same set of circular objects, make sure that the groups do not get the objects that they did in the previous activity.

Watch for students who realize that the relationship between the distance the circle rolls and the diameter is similar to the relationship between the circumference of a circle and the diameter. Encourage them to explain why this might be the case and ask them to share during the discussion.

Addressing

- 7.G.B.4

- 7.RP.A.2.a

Instructional Routines

- MLR7: Compare and Connect

Launch

Demonstrate rolling a circle along a straight line, marking where it starts and stops one complete rotation. Arrange students in groups of 3. Distribute 3 circular objects to each group. Provide access to blank paper (which should be long enough to complete one full rotation of each object) and rulers.

Student Task Statement

Your teacher will give you a circular object.

1. Follow these instructions to create the drawing:
 - On a separate piece of paper, use a ruler to draw a line all the way across the page.
 - Roll your object along the line and mark where it completes one rotation.
 - Use your object to draw tick marks along the line that are spaced as far apart as the diameter of your object.
2. What do you notice?
3. Use your ruler to measure each distance. Record these values in the first row of the table:
 - a. the diameter of your object
 - b. how far your object rolled in one complete rotation
 - c. the quotient of how far your object rolled divided by the diameter of your object

object	diameter	distance traveled in one rotation	distance ÷ diameter

4. If you wanted to trace two complete rotations of your object, how long of a line would you need?
5. Share your results with your group and record their measurements in the table.

6. If each person in your group rolled their object along the entire length of the classroom, which object would complete the most rotations? Explain or show your reasoning.

Student Response

1. A line with 3 equally spaced tick marks and a little more length after the third tick mark.
2. The distance the circle rolled is a little more than three times the diameter.
3. Answers vary. Sample response: One row of the table filled in.

object	diameter	distance traveled in one rotation	distance \div diameter
soup can	6.8 cm	21.5 cm	3.2
tomato paste can	5.4 cm	17 cm	3.1
tuna can	8.5 cm	26.5 cm	3.1

4. Answers vary. Sample response: One rotation was about 21.5 cm so 2 rotations will require about 43 cm.
5. Answers vary. Sample response: Two more rows of the table filled in.
6. The smallest circular object, that is the one with the smallest diameter.

Activity Synthesis

The goal of this discussion is for students to understand that the distance a wheel travels in one complete rotation is equal to the circumference of the wheel.

Gather and display the quotients that students found in the table and emphasize that these values are close to π . Remind students of the activity from the other day when they measured the circumference of circular objects: "When we measure the circumference by wrapping a measuring tape around the circle, the circle stays in place while the measuring tape goes around it. When we roll the circle, we can imagine the measuring tape unwinding while the circle moves."

If desired, discuss which method of measuring the circumference was more precise (rolling the circle or wrapping a measuring tape around it)? Some reasons why measuring the circumference of the circle directly may be more precise include:

- When you roll the circular object, it is hard to keep it going in a straight line.
- It is difficult to mark one rotation precisely.

Support for English Language Learners

Representing, Conversing: MLR7 Compare and Connect. Once students are finished working, ask groups to choose a speaker who will remain at their seat and describe to visitors what was measured and discovered. Student groups will circulate the room, visiting each group. Provide students with the following format for speaking: show the three objects that were measured, describe the data found in your table, then explain what you discovered to the groups that visit. Listen for and amplify language that identifies measuring a rotation as being equal to measuring circumference. This routine will encourage conversation about explaining reasoning and methods for using rotations to find circumference.

Design Principle(s): Cultivate conversation; Maximize meta-awareness

5.3 Rotations and Distance

Optional: 15 minutes

In the previous activity, students saw that the distance a wheel travels in one rotation equals the circumference of the wheel. In this activity, students investigate proportional relationships between the number of rotations of a wheel and the distance that wheel travels. Students make repeated calculations with explicit numbers and then write an equation representing this proportional relationship (MP8).

Monitor for students who appropriately use their equation to answer the last part of each question, which also involves converting between inches and miles.

Addressing

- 7.G.B.4
- 7.RP.A.2.c

Instructional Routines

- MLR5: Co-Craft Questions
- Think Pair Share

Launch

Instruct students to use 3.14 as the approximation for π in these problems. Arrange students in groups of 3–4. Give students 6 minutes of quiet work time, 4 minutes of group discussion, followed by whole-class discussion.

Support for Students with Disabilities

Action and Expression: Internalize Executive Functions. Chunk this task into more manageable parts for students who benefit from support with organizational skills in problem solving. After the first 2–3 minutes of work time, invite 1–2 students to share their responses about the car wheel. Record their calculations on a display as they describe their reasoning.

Supports accessibility for: Organization; Attention

Support for English Language Learners

Writing, Conversing: MLR5 Co-craft Questions. Prior to revealing the task, show short video clips of a car wheel and a bicycle wheel rotating. Ask students to take a moment and think about what they have learned about “circumference” and “rotations” in previous lessons, and invite them to jot down at least two mathematical questions that could be asked about the video clips. Next, invite students to share their questions with a partner. Ask, “Do your questions share any language or ideas in common?”, “Can you combine your ideas into one strong mathematical question the class could answer?” This helps students make comparisons between the sizes and types of wheel rotations they saw and how that applies to the task.

Design Principle(s): Cultivate conversation; Optimize output (for comparison)

Anticipated Misconceptions

Some students may struggle to convert between inches and miles for answering the last part of each question. Remind students that there are 5,280 feet in a mile. Ask students how many inches are in 1 foot. Make sure students arrive at a final answer of 63,360 inches in one mile before calculating the number of rotations made by each wheel.

Student Task Statement

1. A car wheel has a diameter of 20.8 inches.
 - a. About how far does the car wheel travel in 1 rotation? 5 rotations? 30 rotations?
 - b. Write an equation relating the distance the car travels in inches, c , to the number of wheel rotations, x .
 - c. About how many rotations does the car wheel make when the car travels 1 mile? Explain or show your reasoning.
2. A bike wheel has a radius of 13 inches.
 - a. About how far does the bike wheel travel in 1 rotation? 5 rotations? 30 rotations?

- b. Write an equation relating the distance the bike travels in inches, b , to the number of wheel rotations, x .
- c. About how many rotations does the bike wheel make when the bike travels 1 mile? Explain or show your reasoning.

Student Response

- In one revolution, the car travels 20.8π inches or about 65.3 inches. In 5 revolutions, the car will travel 5 times as far or about 327 inches. In 30 revolutions of the wheel, the car will travel $30 \cdot (20.8\pi)$ feet or about or about 1,960 inches.
 - In x revolutions of the wheel, the car travels $20.8\pi x$ inches, $c = 20.8\pi x$.
 - One mile is 5,280 feet or 63,360 inches. Dividing this by 20.8π will give the number of wheel revolutions to go one mile, about 970.
- In one revolution, the bike travels 26π inches or about 81.7 inches. In 5 revolutions, the bike will travel 5 times as far or about 408 inches. In 30 revolutions of the wheel, the bike will travel $30 \cdot (26\pi)$ feet or about or about 2,450 inches.
 - In x revolutions of the wheel, the bike travels $26\pi x$ inches, $b = 26\pi x$.
 - One mile is 5,280 feet or 63,360. Dividing this by 26π will give the number of wheel revolutions to go one mile, about 776.

Are You Ready for More?

Here are some photos of a spring toy.

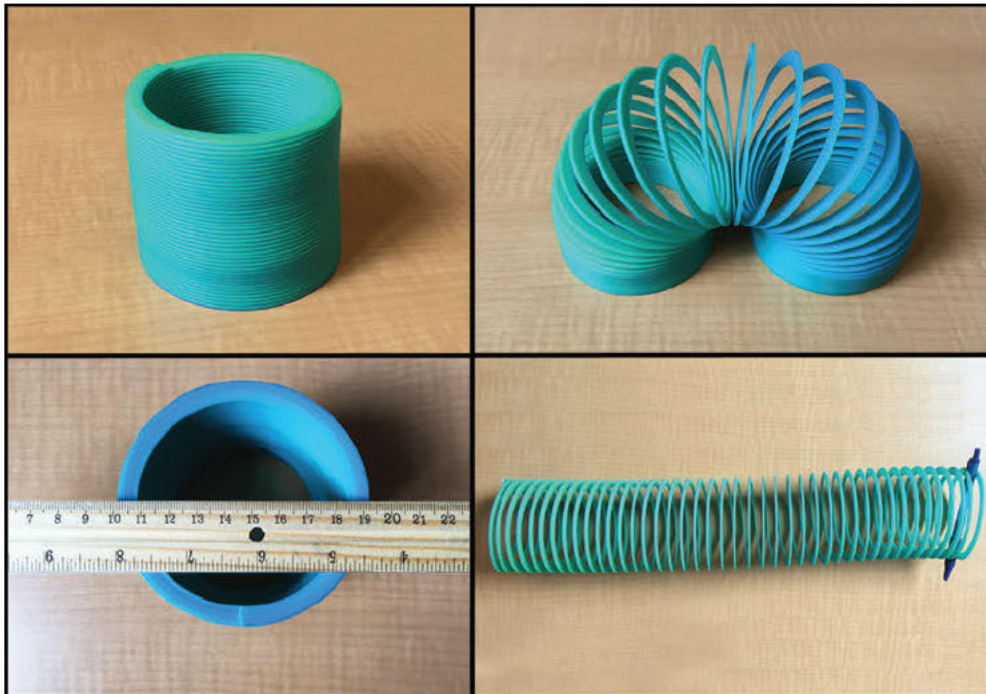

If you could stretch out the spring completely straight, how long would it be? Explain or show your reasoning.

Student Response

We can compute the approximate length if we know the diameter of the circle and the total number of loops. Diameter is ≈ 9.5 cm. There are 42 loops. Therefore, $(9.5)(\pi)(42) \approx 1252.86$. The length is about 1,253 cm, or about 12.5 meters.

Activity Synthesis

The majority of the discussion will occur in small groups, but here are some things to debrief with the whole class:

- “What is the constant of proportionality for each relationship? What does that tell you about the situation?” (65.3 and 81.7, the number of inches each wheel travels per rotation, which is also the circumference of each wheel.)
- “How do the two wheels compare? How can you see this in the equations?” (The bike wheel is larger. The constant of proportionality is larger in the equation representing the bike.)

Poll the class on which wheel makes fewer rotations to travel one mile (the bike). Invite students to explain why. (Its wheels are larger, so it moves farther in one rotation.)

5.4 Rotations and Speed

Optional: 15 minutes

In the previous activity, students relate the distance a wheel travels to the number of rotations the wheel has made. This activity introduces a new quantity, the *speed* the wheel travels. As long as the rate the wheel rotates does not change, there is a nice relationship between the distance the wheel travels, d , and the amount of time, t . With appropriate units, $d = rt$: here r is the speed the wheel travels, which can be calculated in terms of the rate at which the wheel spins. The goal of this activity is to develop and explore this relationship.

As they work on this activity, students will observe repeatedly that the distance the wheel travels is determined by the amount of time elapsed and the rate at which the wheel spins.

Watch for students who use the calculations that they have made in earlier problems as a scaffold for answering later questions. For example, when the car wheels rotate once per second, the car travels about 3.7 mph. When the wheels rotate 5 times per second, that means that the car will travel 5 times as fast or about 18.5 miles per hour. Ask these students to share their work during the discussion.

Addressing

- 7.G.B.4
- 7.RP.A.3

Instructional Routines

- MLR8: Discussion Supports

Launch

Remind students to be careful with units as they work through the problems. Also remind them that there are 5,280 feet in a mile and 12 inches in a foot.

Anticipated Misconceptions

Some students may do the calculations in feet but not know how to convert their answers to miles. Remind them that there are 5,280 feet in 1 mile.

Student Task Statement

The circumference of a car wheel is about 65 inches.

1. If the car wheel rotates once per second, how far does the car travel in one minute?
2. If the car wheel rotates once per second, about how many miles does the car travel in one hour?
3. If the car wheel rotates 5 times per second, about how many miles does the car travel in one hour?
4. If the car is traveling 65 miles per hour, about how many times per second does the wheel rotate?

Student Response

1. There are 60 seconds in a minute so if the car wheel rotates once per second, that's 60 rotations in a minute. At 65 inches per rotation that is 3,900 inches ($60 \cdot 65$). That's the same as 325 feet.
2. There are 60 minutes in an hour, and the car travels 325 feet in a minute so in one hour the car would travel 19,500 feet ($60 \cdot 325$) if the wheels rotate once per second. This is about 3.7 miles, because $19,500 \div 5,280 \approx 3.7$.
3. If the car wheel rotates 5 times per second, then the car will travel 5 times farther than it did when they rotated once per second. So that's about 97,500 feet ($5 \cdot 19500$). This is about 18.5 miles, because $97,500 \div 5,280 \approx 18.5$.
4. If the car travels 65 miles per hour that is 343,200 feet in an hour. Each rotation of the wheel per second amounts to 19,500 feet traveled in one hour. So to travel 343,200 feet in an hour the wheels will rotate $343200 \div 19500$ times per second. That is about 17.6 times.

Activity Synthesis

Have students share their solutions to the first question and emphasize the different ratios and rates that come up when solving this problem. There are

- 65 inches of distance traveled *per* rotation of the wheels

- 1 rotation of the wheel *per* second
- 60 seconds *per* minute

Finally, there are 12 inches *per* foot if students convert the answer to feet. While this is not essential, it is useful in the next problem as feet are a good unit for expressing both inches and miles.

For the last problem, different solutions are possible including:

- In the second question, students have found that the car travels 19,500 feet in an hour if the wheels rotate once per second. This is about 3.7 miles. The number of rotations per second is proportional to the speed. So one way to find how many times the wheels rotate at 65 miles per hour would be to calculate $65 \div 3.7$.
- Students could similarly use their answer to the third question, checking what multiple of 18.5 miles (the distance traveled in an hour at 5 rotations per second) gives 65.
- A calculation can be done from scratch, checking how many inches are in 65 miles, how many seconds are in an hour, and then finding how many rotations of the wheel per second result in traveling 65 miles.

The first of these approaches should be stressed in the discussion as it uses the previous calculations students have made in an efficient way.

Support for English Language Learners

Conversing: MLR8 Discussion Supports. To help students to compare and justify their methods for answering the problem about the car traveling 65 mph, ask them to compare their responses with a partner. Listen for and amplify any language that describes different methods for calculations. Invite students to zero in on “why” there are more differences here. Provide students with question stems to help them compare and contrast, such as: “Do you have the same answer? If not, then why?” (Students may have estimated or converted differently or incorrectly.), “Did you use the same conversions for units?”, and “Why do your answers differ?”
Design Principle(s): Maximize meta-awareness; Cultivate conversation

Lesson Synthesis

Key points in this lesson include:

- The circumference of a circle is how far the circle rolls in one complete revolution.
- If d is the distance a circular wheel rolls in x rotations, then $d = Cx$ where C is the circumference of the wheel.

5.5 Biking Distance

Cool Down: 5 minutes

Addressing

- 7.G.B.4
- 7.RP.A.3

Student Task Statement

The wheels on Noah's bike have a circumference of about 5 feet.

1. How far does the bike travel as the wheel makes 15 complete rotations?
2. How many times do the wheels rotate if Noah rides 40 feet?

Student Response

1. 75 feet, because $5 \cdot 15 = 75$
2. 8 rotations, because $40 \div 5 = 8$

Student Lesson Summary

The circumference of a circle is the distance around the circle. This is also how far the circle rolls on flat ground in one rotation. For example, a bicycle wheel with a diameter of 24 inches has a circumference of 24π inches and will roll 24π inches (or 2π feet) in one complete rotation. There is an equation relating the number of rotations of the wheel to the distance it has traveled. To see why, let's look at a table showing how far the bike travels when the wheel makes different numbers of rotations.

number of rotations	distance traveled (feet)
1	2π
2	4π
3	6π
10	20π
50	100π
x	?

In the table, we see that the relationship between the distance traveled and the number of wheel rotations is a proportional relationship. The constant of proportionality is 2π .

To find the missing value in the last row of the table, note that each rotation of the wheel contributes 2π feet of distance traveled. So after x rotations the bike will travel $2\pi x$ feet. If d is the distance, in feet, traveled when this wheel makes x rotations, we have the relationship:

$$d = 2\pi x$$

Lesson 5 Practice Problems

Problem 1

Statement

The diameter of a bike wheel is 27 inches. If the wheel makes 15 complete rotations, how far does the bike travel?

Solution

$405 \cdot \pi$ or about 1,272 inches (106 feet)

Problem 2

Statement

The wheels on Kiran's bike are 64 inches in circumference. How many times do the wheels rotate if Kiran rides 300 yards?

Solution

About 169 times. There are 36 inches in a yard so 10,800 inches in 300 yards and $10,800 \div 64 \approx 169$.

Problem 3

Statement

The numbers are measurements of radius, diameter, and circumference of circles A and B. Circle A is smaller than circle B. Which number belongs to which quantity?

2.5, 5, 7.6, 15.2, 15.7, 47.7

Solution

Circle A: radius 2.5, diameter 5, circumference 15.7 Circle B: radius 7.6, diameter 15.2, circumference 47.7

(From Unit 3, Lesson 4.)

Problem 4

Statement

Circle A has circumference $2\frac{2}{3}$ m. Circle B has a diameter that is $1\frac{1}{2}$ times as long as Circle A's diameter. What is the circumference of Circle B?

Solution

4 m. If the diameter of Circle B is $1\frac{1}{2}$ times larger than Circle A, its circumference must be as well. We can rewrite to calculate: $(\frac{8}{3})(\frac{3}{2}) = 4$.

(From Unit 3, Lesson 3.)

Problem 5

Statement

The length of segment AE is 5 centimeters.

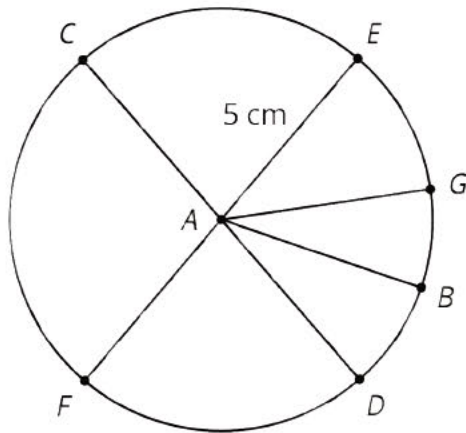

- What is the length of segment CD ?
- What is the length of segment AB ?
- Name a segment that has the same length as segment AB .

Solution

- 10 cm
- 5 cm
- Answers vary. Sample responses: CA , AF , AD , AG , AE

(From Unit 3, Lesson 2.)

Section: Area of a Circle

Lesson 6: Estimating Areas

Goals

- Estimate the area of a complex, real-world region, e.g., a state or province, by approximating it with an irregular polygon, and indicate that it is an approximation when expressing the answer (orally and in writing).
- Explain (orally and in writing) how to calculate the area of an irregular polygon by decomposing it.
- Interpret floor plans and maps in order to identify the information needed to calculate area.

Learning Targets

- I can calculate the area of a complicated shape by breaking it into shapes whose area I know how to calculate.

Lesson Narrative

The purpose of this lesson is for students to practice composing and decomposing irregular regions to calculate their area, in preparation for estimating the area of circles in the next lesson. In the first activity, the region is polygonal and students can calculate an exact answer for the area of the floorplan. In the second activity, students must approximate the area of the state.

Students use polygons to model regions on a map or floorplan (MP4). To complete each task, students need to identify relevant information, choose an appropriate strategy, and make simplifying assumptions. Students also have an opportunity to think about what factors affect the estimates. Students see that the nature of the information we have or could obtain, the assumptions we make, and the estimation methods we use affect how close our estimates are to the actual area measures. Adjust the length of lesson and the expectations on the depth of students' investigations depending on the time available.

Alignments

Building On

- 5.OA.A: Write and interpret numerical expressions.

Addressing

- 7.G.A.1: Solve problems involving scale drawings of geometric figures, including computing actual lengths and areas from a scale drawing and reproducing a scale drawing at a different scale.
- 7.G.B: Solve real-life and mathematical problems involving angle measure, area, surface area, and volume.

- 7.G.B.6: Solve real-world and mathematical problems involving area, volume and surface area of two- and three-dimensional objects composed of triangles, quadrilaterals, polygons, cubes, and right prisms.

Instructional Routines

- Anticipate, Monitor, Select, Sequence, Connect
- MLR5: Co-Craft Questions
- MLR7: Compare and Connect
- Notice and Wonder
- Number Talk
- Think Pair Share

Required Materials

Geometry toolkits

For grade 6: tracing paper, graph paper, colored pencils, scissors, and an index card to use as a straightedge or to mark right angles.

For grades 7 and 8: everything in grade 6, plus a ruler and protractor. Clear protractors with no holes and with radial lines printed on them are recommended.

Notes: (1) "Tracing paper" is easiest to use when it's a smaller size. Commercially-available "patty paper" is 5 inches by 5 inches and ideal for this. If using larger sheets of tracing paper, consider cutting them down for student use. (2) When compasses are required in grades 6-8 they are listed as a separate Required Material.

Required Preparation

Provide access to geometry toolkits.

Student Learning Goals

Let's estimate the areas of weird shapes.

6.1 Mental Calculations

Warm Up: 5 minutes

This warm-up encourages using different strategies to perform arithmetic operations mentally. One of these is the idea of compensation. These methods for performing mental math are arithmetic analogues of the composition and decomposition techniques students use in this lesson to calculate areas of shapes.

Building On

- 5.OA.A

Instructional Routines

- Number Talk

Launch

Display one problem at a time. Give students 1 minute of quiet think time per problem and ask them to give a signal when they have an answer and a strategy.

Student Task Statement

Find a strategy to make each calculation mentally:

$$599 + 87$$

$$254 - 88$$

$$99 \cdot 75$$

Student Response

- Taking one away from 87 and adding it to 599 turns this into $600 + 86$, which is 686.
- Instead of subtracting 88, it is easier to subtract 90. Since this is subtracting 2 more, 254 needs to be increased by 2: $256 - 90 = 166$.
- Since 99 is 1 short of 100, this is the same as 100 times 75 minus 75, or 7425.

Activity Synthesis

Ask students to share their ideas for how to perform these calculations mentally.

One key idea to bring out, for all three calculations, is the idea of compensation: identifying numbers close to the given ones for which the calculation can be done more efficiently. For $599 + 87$, since 599 is only one away from 600 (a nice round number), it is natural to change 599 to 600. Adding 1 to 599 means that we need to *subtract* one from 87 to keep the sum the same. So the answer is $600 + 86$, or 686. For $254 - 88$, students may identify 90 or 100 as a nice number near 88 which is simpler to subtract. Subtracting 100 would be subtracting 12 more than 88, so we need to add 12 to 254. So the answer is $266 - 100$, or 166. Finally for $99 \cdot 75$, 99 is 1 short of 100, so $99 \cdot 75$ is 75 short of 7500 or 7425.

Tell students that in this lesson they are going to use these kinds of strategies in a geometric context to find areas efficiently.

Support for English Language Learners

Speaking: MLR8 Discussion Supports: Display sentence frames to support students when they explain their strategy. For example, "First, I ____ because . . ." or "I noticed ____ so I . . ." Some students may benefit from the opportunity to rehearse what they will say with a partner before they share with the whole class.

Design Principle(s): Optimize output (for explanation)

6.2 House Floorplan

15 minutes

In this activity students calculate the area of an irregular shape presented in a scale drawing. In this case, students can calculate the area exactly by composing and decomposing triangles and parallelograms.

This activity draws upon MP7 in a geometric context much like the warm-up did in an arithmetic context. Choosing an appropriate way to compose and decompose the floor plan of the house in order to make calculations efficient is analogous to choosing how to rewrite numbers in order to make finding their sum, difference, or product as efficient as possible.

Monitor for students who focus on decomposing the floor plan and for students who compose the floor plan with additional shapes to make a rectangle. For students who focus on decomposing the floor plan, the biggest challenge will be the right side of the house.

Addressing

- 7.G.A.1
- 7.G.B.6

Instructional Routines

- Anticipate, Monitor, Select, Sequence, Connect
- MLR5: Co-Craft Questions

Launch

Given students 4–5 minutes of quiet work time followed by whole-class discussion.

Support for Students with Disabilities

Action and Expression: Internalize Executive Functions. Provide students with a graphic organizer to organize the information provided in the problem and to structure their problem-solving strategy. The graphic organizer should include the prompts: “What do I need to find out?”, “What do I need to do?”, “How I solved the problem.”, and “How I know my answer is correct.”
Supports accessibility for: Language; Organization

Support for English Language Learners

Conversing: MLR5 Co-Craft Questions. Display the diagram of the floor plan without revealing the task statement to students. Ask pairs of students to write a list of possible mathematical questions about the situation. Then, invite pairs to share their questions with the class. This will provide students with an opportunity to orient themselves to the context, ensuring that students understand the components of a floor plan, and also to produce the language of mathematical questions related to finding the area of irregular figures.

Design Principle(s): Cultivate conversation; Support sense-making

Anticipated Misconceptions

If students struggle getting started finding the area of the floor plan, consider suggesting that they use composition and decomposition to break the floor plan up into familiar shapes whose area can be calculated.

Student Task Statement

Here is a floor plan of a house. Approximate lengths of the walls are given. What is the approximate area of the home, including the balcony? Explain or show your reasoning.

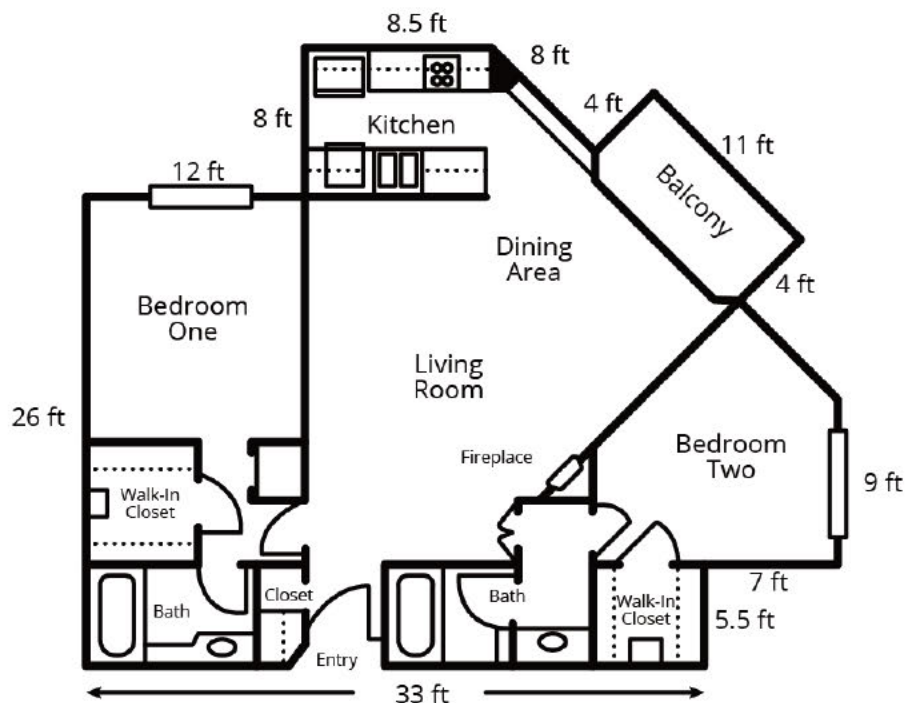

Student Response

About $1,080 \text{ ft}^2$. Sample reasoning: Enclose the house plan with a rectangle. One side of the rectangle is 40 ft because $33 + 7 = 33$. The other side is 34 ft because $26 + 8 = 34$. So the area of the enclosing rectangle is 1,360 sq ft, since $40 \cdot 34 = 1,360$. Next, find the areas of the two smaller rectangles outside the house (at upper left and lower right), then subtract those areas from 1,360 sq ft. The two rectangles are 96 sq ft and 38.5 sq ft because $12 \cdot 8 = 96$ and $(5.5) \cdot 7 = 38.5$. Next, find the area of the right triangle at upper right, and then subtract it: the triangle includes part of the balcony which will be added back in later. The area of the triangle is about 190 sq ft, because $\frac{1}{2} \cdot (19.5) \cdot (19.5) = 190.125$. The balcony is 44 sq ft, since $4 \cdot 11 = 44$. $1360 - 96 - 38.5 - 190 + 44 = 1,079.5$. Therefore, the area of the house is about 1,080 sq ft.

Activity Synthesis

Select students to share their reasoning in this sequence:

- decomposing the floorplan into various rectangles and triangles
- composing the floorplan with other shapes to create a large rectangle

Composing to make a bigger shape and then taking away the excess area is very much like finding $99 \cdot 75$ in the warm-up by first calculating the larger product $100 \cdot 75$ and then removing 75. In both cases, something is being added to facilitate the calculation and then an adjustment is made at the end to take away the excess that was added.

6.3 Area of Nevada

15 minutes

In this activity students first identify the information needed to estimate the area of the state of Nevada from a map. Next, they use strategies developed in earlier work to make an estimate. The area can only be estimated as the shape is more complex and not a polygon. Like in the previous activity, monitor for these two strategies:

- Enclosing the image of the state in a rectangle, finding the area of the rectangle, and subtracting the area of a right triangle
- Decomposing the image of the state into a rectangle and a right triangle, finding the area of each, and combining the two

These two methods work equally well for this shape. Also, some students may notice and account for the missing area in the southeast corner of the state and others may not. As students work, notice the approaches they use and select one or two students who use each strategy to share during the discussion.

Addressing

- 7.G.A.1
- 7.G.B

Instructional Routines

- MLR7: Compare and Connect
- Notice and Wonder
- Think Pair Share

Launch

Arrange students in groups of 2. Have students close their books or devices. Display this map of Nevada that does not have a scale, and invite students to share what they notice and wonder.



Some things students might notice:

- The shape of the state looks like a rectangle with a corner cut off and a bite taken out.
- The shape of the state could be decomposed into a rectangle and a triangle.

Some things students might wonder:

- How long are the side lengths of the state?
- What is the area of Nevada?



Ask students what information they would need to know to calculate the area of Nevada. If desired, show students the scale and ask them to estimate the needed measurements. Alternatively, instruct students to open their books or devices. Give students 5 minutes of quiet work time followed by partner discussion.

Support for Students with Disabilities

Engagement: Develop Effort and Persistence. Encourage and support opportunities for peer interactions. Invite students to talk about their ideas with a partner before writing them down. Display sentence frames to support students as they discuss and explain their strategies. For example, “We are trying to....”, “How did you get...?”, and “First, I ____ because....”
Supports accessibility for: Language; Social-emotional skills

Anticipated Misconceptions

If students decompose the image of the state into a rectangle and triangle, they may use the 270 miles for a side length of the rectangle instead of finding the difference of the 490 miles on the opposite side and 270 miles. Ask them to check their answer with a partner and reevaluate their calculations.

Student Task Statement

Estimate the area of Nevada in square miles. Explain or show your reasoning.



Student Response

Answers vary. Sample response: About 110,000 square miles. Possible strategies:

- Enclose Nevada with a 320 mi by 490 mi rectangle, and subtract the area of the right triangle in the lower left corner that has side lengths of 320 mi and 270 mi:
 $(320 \cdot 490) - \left(\frac{1}{2} \cdot 320 \cdot 270\right) = 113,600$. The area is about 110,000 square miles.
- Decompose Nevada into a rectangle and a right triangle:
 $(320 \cdot 220) + \left(\frac{1}{2} \cdot 320 \cdot 270\right) = 113,600$. The area is about 110,000 square miles.

Are You Ready for More?

The two triangles are equilateral, and the three pink regions are identical. The blue equilateral triangle has the same area as the three pink regions taken together. What is the ratio of the sides of the two equilateral triangles?

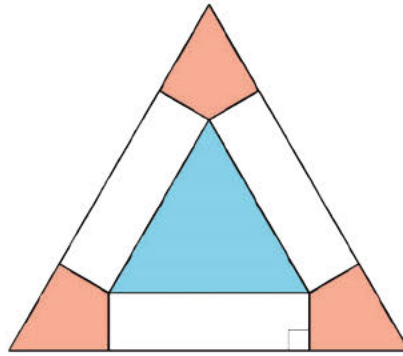

Student Response

2 : 1 or 1 : 2. Since both triangles are equilateral, the three pink regions are identical, and the pink regions have the same area as the blue region, they must fit inside as shown.

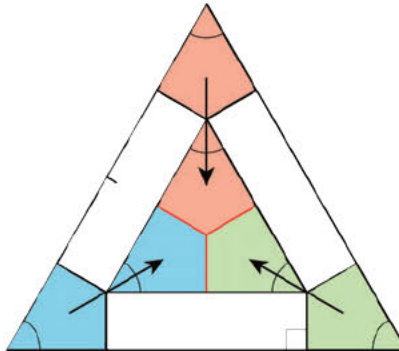

Activity Synthesis

The goal of this discussion is for students to understand the distinction between calculating the areas of geometric objects and estimating areas of regions on maps.

First, display these questions for students to discuss with their partners:

- How did you make your estimate?
- If your estimates are not the same, are they close? What accounted for the difference?

Ask students how finding the area of Nevada in this activity was the same as finding the area of the floorplan in the previous activity and how it was different.

- One way it was the same was that it was still helpful to decompose the region into rectangles and triangles. Strategies involving addition and strategies involving subtraction were both possible.
- An important difference is that the state is not a polygon. Some of the boundaries are not straight and the overall land is not completely flat. Assuming the state is flat and approximating the boundaries with line segments both lead to some error in the estimate.

Consider telling students that the actual area of Nevada is about 110,560 square miles.

Support for English Language Learners

Speaking: MLR7 Compare and Connect. Use this routine when students present their strategy for finding the area of Nevada. Ask students to consider what is the same and what is different about each approach. Draw students' attention to the language used to describe the different ways the area can be calculated (decompose, rearrange, enclose, area, etc.). These exchanges can strengthen students' mathematical language use and reasoning to make sense of strategies used to calculate the area of irregular figures.

Design Principle(s): Maximize meta-awareness; Support sense-making

Lesson Synthesis

Point out that students estimated areas of both large and small things in the world by approximating them with polygons. Go over the different strategies students used to estimate the area in this lesson and emphasize we can find the area of any polygon by decomposing it into triangles and rectangles and using formulas we know to find the area. In practice, it is important to be strategic when composing and decomposing, taking advantage of measurements that are known and avoiding measurements that are unknown or difficult to calculate.

Ask students to reflect on their recent work in finding area and discuss the following questions:

- "What things are important to think about when asked to find the area of a figure?"
- "What things do we know help us find area of any figure?"

It is important to consider the shape of the region, how polygons are helpful, and the ways polygons can be decomposed, rearranged or enclosed to find the area of the region.

6.4 The Area of Alberta

Cool Down: 5 minutes

Addressing

- 7.G.A.1
- 7.G.B.6

Launch

Consider telling students that Alberta is a province in Canada.

Student Task Statement

Estimate the area of Alberta in square miles. Show your reasoning.



Student Response

About 250,000 square miles. Sample reasoning: Alberta can be surrounded with a 410-mile-by-760-mile rectangle with a 290-mile-by-230-mile triangle removed in the lower left corner. The answer has been rounded because the part missing in the lower left is not exactly a triangle.

Student Lesson Summary

We can find the area of some complex polygons by surrounding them with a simple polygon like a rectangle. For example, this octagon is contained in a rectangle.

The rectangle is 20 units long and 16 units wide, so its area is 320 square units. To get the area of the octagon, we need to subtract the areas of the four right triangles in the corners. These triangles are each 8 units long and 5 units wide, so they each have an area of 20 square units. The area of the octagon is $320 - (4 \cdot 20)$ or 240 square units.

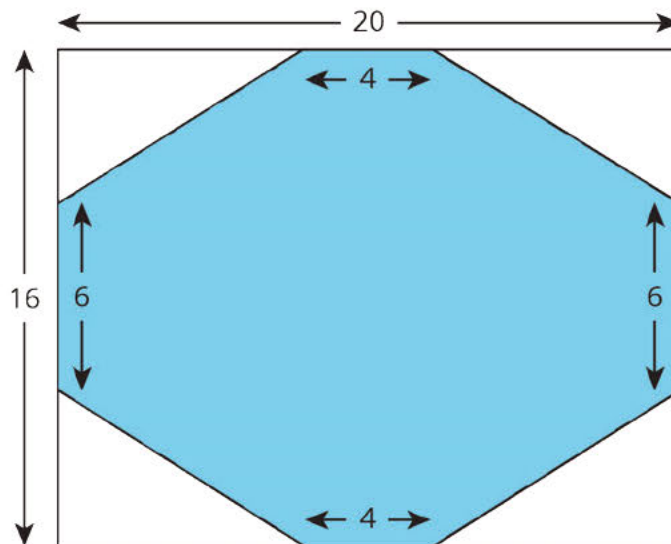

We can estimate the area of irregular shapes by approximating them with a polygon and finding the area of the polygon. For example, here is a satellite picture of Lake Tahoe with some one-dimensional measurements around the lake.

The area of the rectangle is 160 square miles, and the area of the triangle is 17.5 square miles for a total of 177.5 square miles. We recognize that this is an approximation, and not likely the exact area of the lake.

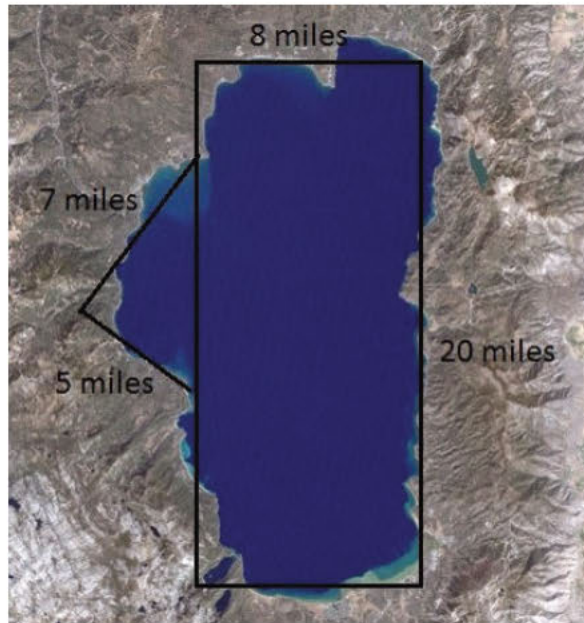

Lesson 6 Practice Problems

Problem 1

Statement

Find the area of the polygon.

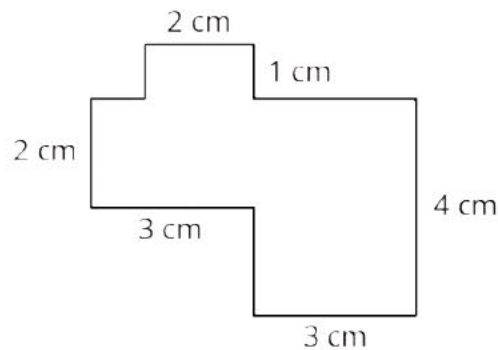

Solution

20 cm^2 since the shape can be divided (vertically) into rectangles of area 2, 6, and 12 square centimeters.

Problem 2

Statement

- a. Draw polygons on the map that could be used to approximate the area of Virginia.

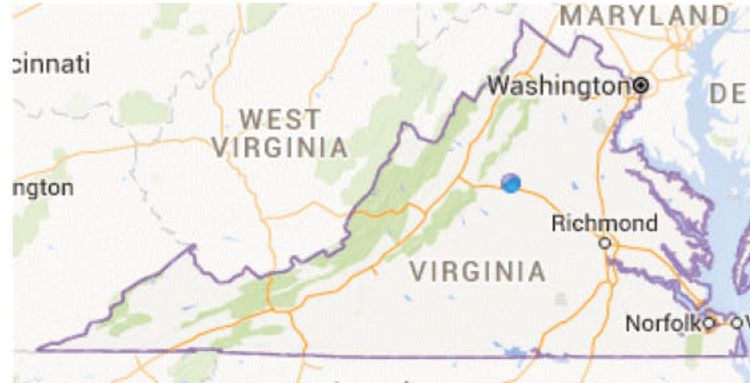

- b. Which measurements would you need to know in order to calculate an approximation of the area of Virginia? Label the sides of the polygons whose measurements you would need. (Note: You aren't being asked to calculate anything.)

Solution

- a. Answers vary. There are many possible ways to draw polygons that would approximate the area of Virginia. One sample response is shown below. Other choices could be made to yield a more or less precise approximation.

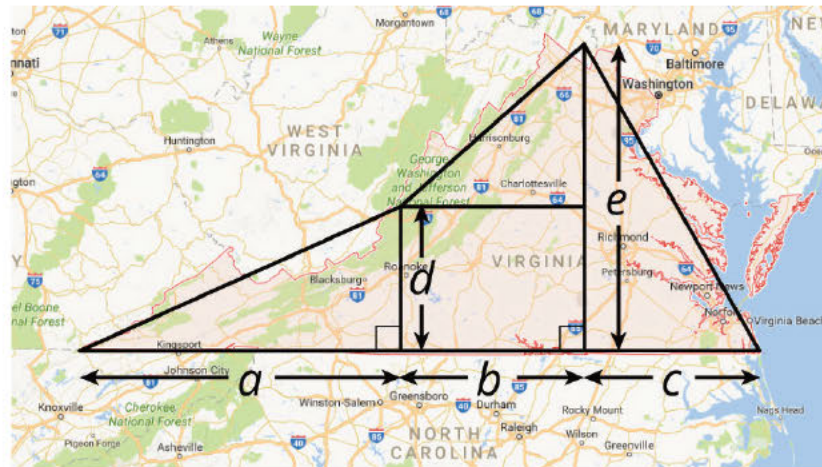

- b. Answers vary. For rectangles, parallelograms, and triangles, you need both base and height. In the example above, the variables represent measurements needed to find the area of the polygons.

Problem 3

Statement

Jada's bike wheels have a diameter of 20 inches. How far does she travel if the wheels rotate 37 times?

Solution

$37 \cdot 20 \cdot \pi$ or about 2,325 in.

(From Unit 3, Lesson 5.)

Problem 4

Statement

The radius of Earth is approximately 6,400 km. The equator is the circle around Earth dividing it into the northern and southern hemispheres. (The center of the earth is also the center of the equator.) What is the length of the equator?

Solution

$6,400 \cdot 2 \cdot \pi$ is about 40,000 km

(From Unit 3, Lesson 4.)

Problem 5

Statement

Here are several recipes for sparkling lemonade. For each recipe, describe how many tablespoons of lemonade mix it takes per cup of sparkling water.

- 4 tablespoons of lemonade mix and 12 cups of sparkling water
- 4 tablespoons of lemonade mix and 6 cups of sparkling water
- 3 tablespoons of lemonade mix and 5 cups of sparkling water
- $\frac{1}{2}$ tablespoon of lemonade mix and $\frac{3}{4}$ cups of sparkling water

Solution

- $\frac{4}{12}$ or $\frac{1}{3}$ tablespoons lemonade mix per cup of sparkling water
- $\frac{4}{6}$ or $\frac{2}{3}$ tablespoons lemonade mix per cup of sparkling water
- $\frac{3}{5}$ or 0.6 tablespoons of lemonade mix per cup of sparkling water
- $\frac{1}{2} \div \frac{3}{4}$ or $\frac{2}{3}$ tablespoon of lemonade mix per cup of sparkling water

(From Unit 2, Lesson 1.)

Lesson 7: Exploring the Area of a Circle

Goals

- Create a table and a graph that represent the relationship between the diameter and area of circles of various sizes, and justify (using words and other representations) that this relationship is not proportional.
- Estimate the area of a circle on a grid by decomposing and approximating it with polygons.

Learning Targets

- If I know a circle's radius or diameter, I can find an approximation for its area.
- I know whether or not the relationship between the diameter and area of a circle is proportional and can explain how I know.

Lesson Narrative

This lesson is the first of two lessons that develop the formula for the **area of a circle**. Students start by estimating the area inside different circles, deepening their understanding of the concept of area as the number of unit squares that cover a region, and discovering that area (unlike circumference) is not proportional to diameter.

Next, they investigate how the area of a circle compares to the area of a square that has side lengths equal to the circle's radius. Students may choose tools strategically from their geometry toolkits to help them make these comparisons (MP5). Students find an approximate formula: the area of a circle is a little bigger than $3r^2$, and they check their earlier estimates with this formula. At this point, it is a reasonable guess that the exact formula is $A = \pi r^2$, but the next lesson will focus on using informal dissection arguments to establish this formula.

When we say "area of a circle" we technically mean "area of the region enclosed by a circle." However, "area of a circle" is the phrase most commonly used.

Alignments

Addressing

- 7.G.A: Draw, construct, and describe geometrical figures and describe the relationships between them.
- 7.G.B: Solve real-life and mathematical problems involving angle measure, area, surface area, and volume.
- 7.G.B.4: Know the formulas for the area and circumference of a circle and use them to solve problems; give an informal derivation of the relationship between the circumference and area of a circle.

- 7.RP.A.2.a: Decide whether two quantities are in a proportional relationship, e.g., by testing for equivalent ratios in a table or graphing on a coordinate plane and observing whether the graph is a straight line through the origin.

Building Towards

- 7.G.B.4: Know the formulas for the area and circumference of a circle and use them to solve problems; give an informal derivation of the relationship between the circumference and area of a circle.

Instructional Routines

- Group Presentations
- MLR2: Collect and Display
- MLR7: Compare and Connect

Required Materials

Copies of blackline master

Geometry toolkits

For grade 6: tracing paper, graph paper, colored pencils, scissors, and an index card to use as a straightedge or to mark right angles.

For grades 7 and 8: everything in grade 6, plus a ruler and protractor. Clear protractors with no holes and with radial lines printed on them are recommended.

Notes: (1) "Tracing paper" is easiest to use when it's a smaller size. Commercially-available "patty paper" is 5 inches by 5 inches and ideal for this. If using larger sheets of tracing paper, consider cutting them down for student use. (2) When compasses are required in grades 6-8 they are listed as a separate Required Material.

Required Preparation

For the first activity, you will need the Estimating Areas of Circles blackline master. Prepare 1 copy for every 12 students. (Each group of 2 students gets one of the pages.)

For the second activity, make sure students have access to their geometry toolkits, especially tracing paper and scissors, if they so choose (but try not to influence students' choices about what tools to use).

Student Learning Goals

Let's investigate the areas of circles.

7.1 Estimating Areas

Warm Up: 5 minutes

The purpose of this warm-up is for students to estimate the area of a circle using what they know about the area of polygons. The first picture with no grid prompts students to visualize decomposing and rearranging pieces of the figures in order to compare their areas. Using the grid, students are able to estimate the areas and discuss their strategies.

Addressing

- 7.G.B

Instructional Routines

- MLR7: Compare and Connect

Launch

Arrange students in groups of 3. Display the first image with no grid for all to see.

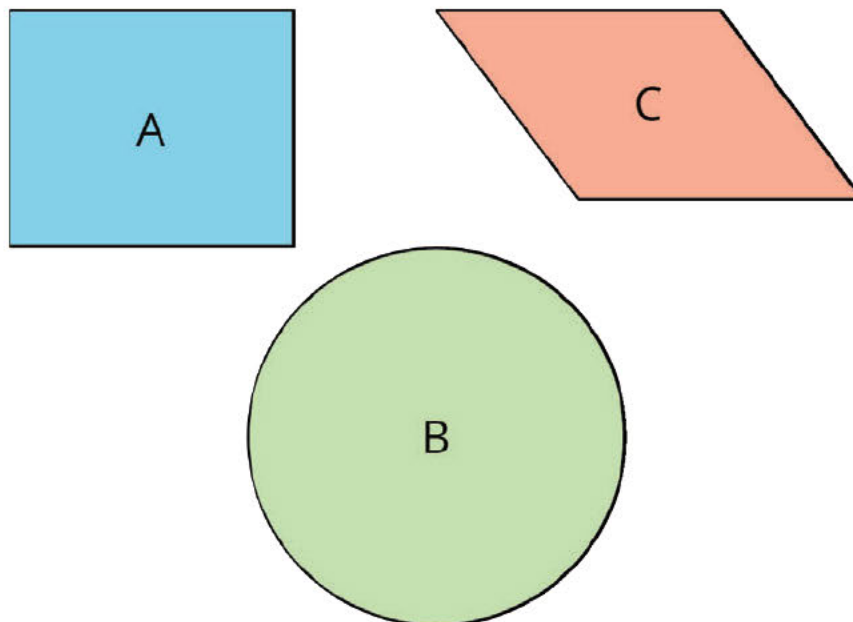

Ask students to give a signal when they have an idea which figure has the largest area. Give students 30 seconds of quiet think time followed by 1 minute to discuss their reasoning with a partner. Next display the image on a grid.

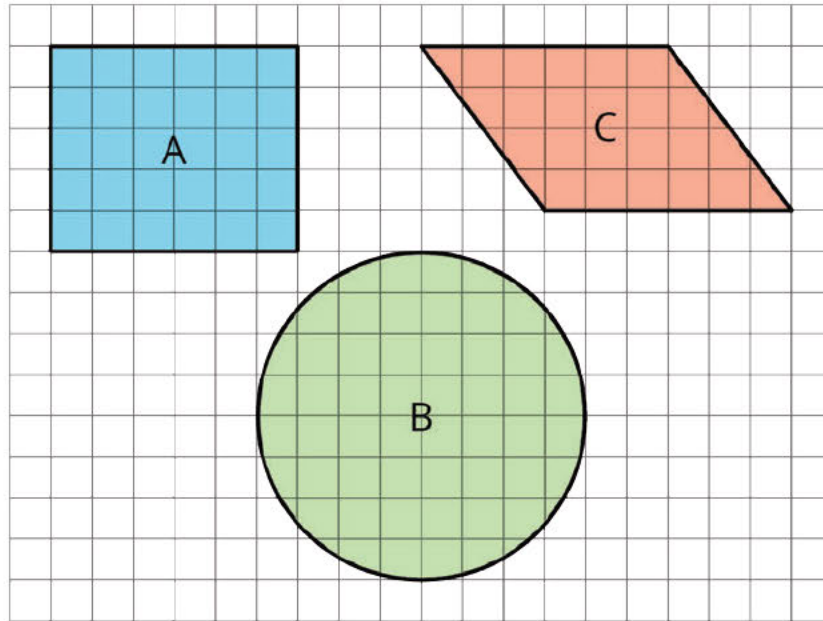

Ask students to discuss with their group how they would find or estimate the area of each of the figures. Tell them to share their ideas with their group.

Student Task Statement

Your teacher will show you some figures. Decide which figure has the largest area. Be prepared to explain your reasoning.

Student Response

Figure B appears to be the largest.

To find the area of Figure A, multiply the length and width. To find the area of Figure C, multiply the length of the base and its corresponding height. To estimate the area of Figure C, find the area of the rectangle in the middle, and then count partial squares. Or, find the enclosing rectangle and subtract the empty partial squares.

Activity Synthesis

Invite selected students to share their strategies and any information in the image that would inform their responses. After each explanation, solicit questions from the class that could help the student clarify his or her reasoning. Ask the whole class to discuss their strategies for finding or estimating the area. Ask them if they think it is possible to calculate the area of the circle *exactly*. Tell them that trying to find the area of a circle will be the main topic for this lesson.

Refer to MLR 7 (Compare and Connect). Prompt students with questions like: What information was useful for solving the problem? What formulas or prior knowledge did you use to approach the problem? What did you do that was similar to another student? How did you estimate when there was not a complete grid block?

7.2 Estimating Areas of Circles

20 minutes (there is a digital version of this activity)

In a previous lesson, students measured various circular objects and graphed the measurements to see that there appears to be a proportional relationship between the diameter and circumference of a circle. In this activity, students use a similar process to see that the relationship between the diameter and area of a circle is *not* proportional. This echoes the earlier exploration comparing the length of a diagonal of a square to the area of the square, which was also not proportional.

Each group estimates the area of one smaller circle and one larger circle. After estimating the area of their circles, students graph the class's data on a coordinate plane to notice that the data points curve upward instead of making a straight line through the origin. Watch for students who use different methods for estimating the area of the circles (counting full and partial grid squares inside the circle, surrounding the circle with a square and removing full and partial grid squares) and invite them to share in the discussion.

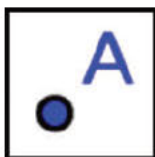

For classes using the digital version, students can record the class data in the spreadsheet and graph points directly on the grid using the Point tool. Note: you have to click on the graph side of the applet for the point tool to appear.

Addressing

- 7.RP.A.2.a

Building Towards

- 7.G.B.4

Instructional Routines

- Group Presentations
- MLR7: Compare and Connect

Launch

Arrange students in groups of 2.

For classes using the print version, distribute the grids with the circles already drawn—one set of circles to each group of students from the Estimating Areas of Circles blackline master.

For classes using the digital version of the activity, assign each group of students a pair of diameters from this set:

- 2 cm and 16 cm

- 5 cm and 10 cm
- 3 cm and 12 cm
- 6 cm and 18 cm
- 4 cm and 20 cm
- 7 cm and 14 cm

Encourage students to look for strategies that will help them efficiently count the area of their assigned circles. Give students 4–5 minutes of group work time.

After students have finished estimating the areas of their circles, display the blank coordinate grid from the activity statement and have students plot points for their measurements. Give students 3–4 minutes of quiet work time, followed by whole-class discussion.

Anticipated Misconceptions

Some students might be unsure on how to count the squares around the border of the circle that are only partially included. Let them come up with their own idea, but if they need additional support, suggest that they round up to a whole square when it looks like half or more of the square is within the circle and round down to no square when it looks like less than half the square is within the circle.

Student Task Statement

Your teacher will give your group two circles of different sizes.

1. For each circle, use the squares on the graph paper to measure the diameter and estimate the **area of the circle**. Record your measurements in the table.

diameter (cm)	estimated area (cm ²)

2. Plot the values from the table on the class coordinate plane. Then plot the class's data points on your coordinate plane.

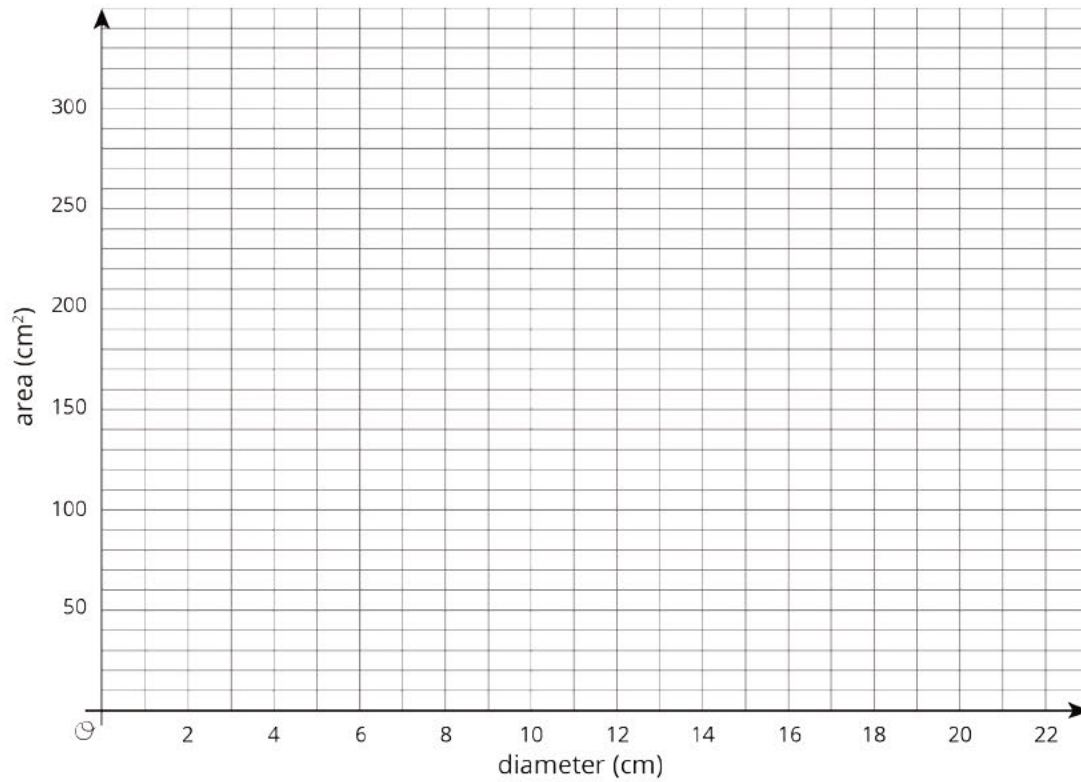

3. In a previous lesson, you graphed the relationship between the diameter and circumference of a circle. How is this graph the same? How is it different?

Student Response

1. Each group has 2 of the rows from this table (and the values in the right column are approximate):

diameter (cm)	estimated area (cm ²)
2	3
3	7
4	12
5	19
6	27
7	38
10	78
12	108
14	147
16	200
18	250
20	312

Possible solutions for a circle of radius 6:

- Count the number of squares that fit completely inside the circle to get an underestimate: 88 cm^2 . Next, count the number of squares that cover any part of the circle to get an overestimate: 128 cm^2 . Then, average the two: about 108 cm^2 .
- Count the number of squares that fit completely inside the circle: 88 cm^2 . Next, estimate the partial squares that make up the gaps: about 24 cm^2 . Then, add the two: about 112 cm^2 total.

2.

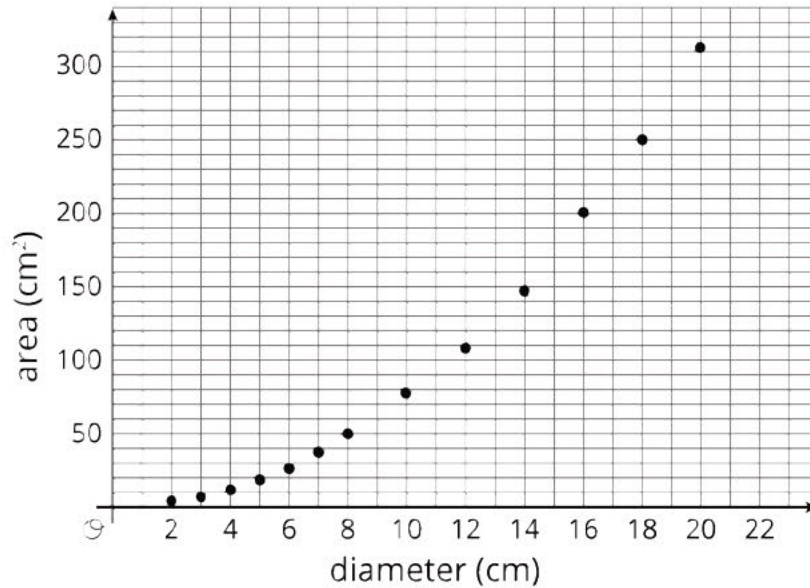

3. Both the graphs of circumference and area go up as the diameter increases. However, the area graph goes up faster the bigger the diameter, while the circumference goes up by about the same amount every time. That means the area graph curves upward instead of being a straight line through the origin, so it does not represent a proportional relationship.

Are You Ready for More?

How many circles of radius 1 unit can you fit inside each of the following so that they do not overlap?

1. a circle of radius 2 units?
2. a circle of radius 3 units?
3. a circle of radius 4 units?

If you get stuck, consider using coins or other circular objects.

Student Response

1. 2
2. 7
3. 11

Activity Synthesis

Invite selected students to share their strategies for estimating the area of their circle.

Next, ask "Is the relationship between the diameter and the area of a circle a proportional relationship?" (No.) Invite students to explain their reasoning. (The points do not lie on a straight line through $(0, 0)$.)

To help students see and express that the relationship is not proportional, consider adding a column to the table of measurements to record the quotient of the area divided by the diameter. Here is a table of sample values.

diameter (cm)	estimated area (cm ²)	area ÷ diameter
2	3	1.5
3	7	2.3
4	12	3.0
5	19	3.8
6	27	4.5
7	38	5.4
10	78	7.8
12	108	9.0
14	147	10.5
16	200	12.5
18	250	13.9
20	312	15.6

Remind students that there is a proportional relationship between diameter and circumference, even though there is not between diameter and area. Recall that students saw the same phenomenon when they examined the relationship between the diagonal of a square and its perimeter (proportional) and the diagonal of a square and its area (not proportional).

Support for English Language Learners

Speaking, Listening: MLR7 Compare and Connect. Ask students to prepare a visual display that shows how they estimated the area of their circle. As they work, look for students with different strategies that overestimate or underestimate the area. As students investigate each other's work, ask them to share what worked well in a particular approach. Listen for and amplify any comments that make the estimation of the area more precise. Then encourage students to make connections between the expressions and diagrams used to estimate the area of a circle. Listen for and amplify language students use to make sense of the area of a circle as the number of unit squares enclosed by the circle. This will foster students' meta-awareness and support constructive conversations as they compare strategies for estimating the area of a circle and make connections between expressions and diagrams used to estimate the area of a circle. *Design Principles(s): Cultivate conversation; Maximize meta-awareness*

7.3 Covering a Circle

Optional: 20 minutes

In this activity students compare the area of a circle of radius r with the area of a square of side length r through trying to cover the circle with different amounts of squares. The task is open-ended so the students can look for a very rough estimate or can look for a more precise estimate. In either case, they find that the circle has area greater than 2 times the square, less than 4 times the square, and that 3 times the square looks like a good estimate.

In the discussion, students will generalize their estimates for different values of r . An optional video shows how to cut up 3 squares and place them inside a circle. Since there is a little white space still showing around the cut pieces, that means that the area of a circle with radius r is close to, but a little bit more than, $3r^2$.

Watch for how students use the square and circle provided in the problem (MP5).

Addressing

- 7.G.A

Building Towards

- 7.G.B.4

Instructional Routines

- MLR2: Collect and Display

Launch

Keep students in the same groups. Provide access to geometry toolkits.

Support for Students with Disabilities

Action and Expression: Provide Access for Physical Action. Provide access to tools and assistive technologies such as physical cutouts of the square or a digital version that students can manipulate.

Supports accessibility for: Visual-spatial processing; Conceptual processing; Organization

Support for English Language Learners

Conversing, Reading: MLR2 Collect and Display. As students work in groups to make sense of the problem, circulate and listen to groups as they discuss the number of squares it would take to cover the circle exactly. Write down the words and phrases students use to justify why it definitely takes more than 2 squares and less than 4 squares to cover the circle exactly. As groups cut and reposition the squares in the circle, include a diagram or picture to show this in the visual display. As students review the language and diagrams collected in the visual display, encourage students to clarify the meaning of a word or phrase. This routine will provide feedback to students in a way that supports sense-making while simultaneously increasing meta-awareness of language.

Design Principle(s): Support sense-making; Maximize meta-awareness

Anticipated Misconceptions

Students may focus solely on the radius of the circle and side length of the square, not relating their work to area. As these students work, ask them what they find as they try to cover the circle each time. Reinforce the idea that as they cover the circle, they are comparing the area of the circle and squares.

If students arrive at the idea that 4 squares suffice to completely cover the circle, ask them if there is any excess. Could they cover the square with $3\frac{1}{2}$ squares, for example?

Student Task Statement

Here is a square whose side length is the same as the radius of the circle.

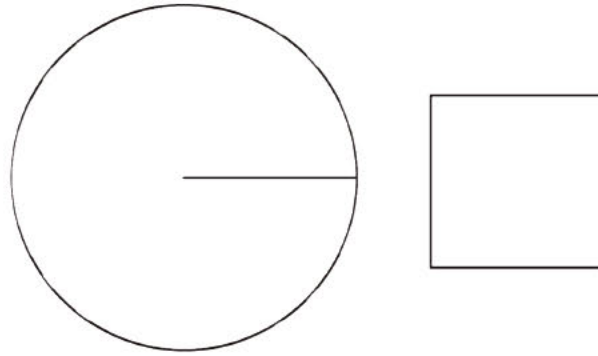

How many of these squares do you think it would take to cover the circle exactly?

Student Response

It definitely takes more than 2 squares and less than 4 squares. It would probably take somewhere close to 3 squares. Sample reasoning: I traced the square onto tracing paper 4 times and cut them out. I saw that only 3 of these would fit completely on the circle.

Activity Synthesis

The goal of this discussion is for students to recognize that the area of the circle with radius r is a little more than $3r^2$, for any size circle.

Ask the class:

- “Can two squares completely cover the circle?” (No.)
- “Can four squares completely cover the circle?” (Yes.)
- “Can three squares completely cover the circle?” (It's hard to tell for sure.)

Invite students to explain their reasoning. Consider displaying this image for students to refer to during their explanations.

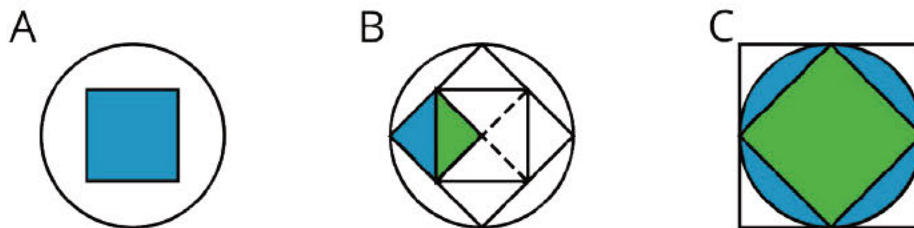

- Figure A shows that the area of the circle is larger than the area of the square, because the square can be placed inside the circle and more white space remains.
- Figure B shows that the area of the circle is larger than twice the area of the square, because the squares can be cut and repositioned to fit within the circle and some white space still remains.
- Figure C shows that the area of the circle is smaller than four times the area of the square, because the squares completely cover the circle and the corners go outside the circle.

- Figure C also shows that it is reasonable to conclude the the area of the circle is approximately equal to three times the area of the square, because it looks like the blue shaded regions (inside the circle) are close in area to the white shaded regions (outside the circle but inside the square).

Consider showing this video which makes it more apparent that three of these squares can be cut and repositioned to fit entirely within the circle.

Video 'Area of a Circle' available here: <https://player.vimeo.com/video/304137873>.

Since there is a little white space remaining around the cut pieces, that means it would take a little bit more than three squares to cover the circle. The area of the circle is a little bit more than three times the area of one of those squares. At this point, some students may suggest that it takes exactly π squares to cover the circle. This will be investigated in more detail in the next lesson. If not mentioned by students, it does *not* need to be brought up in this discussion.

Next, guide students towards the expression $3r^2$ by asking questions like these:

- “Does the size of the circle affect how many radius squares it takes to cover the circle?” (No, the entire picture can be scaled.)
- “If the radius of the circle were 4 units, what would be the area of the square? What would be the area of the circle?” (16 units² and a little more than $3 \cdot 16$, or 48 units²)
- “If the radius of the circle were 11 units, what would be the area of the square? What would be the area of the circle?” (121 units² and a little more than $3 \cdot 121$, or 363 units²)
- “If the circle has radius r , what would be the area of the square? What would be the area of the circle?” (r^2 units² and a little more than $3r^2$ units²)

Lesson Synthesis

Pose the following question: “If you have a square with side lengths equal to the radius of a circle, how many of these squares does it take to cover the circle?”

Tell students what approximation to use for this value. Have students use this approximation along with the area of such a square to calculate the *area* of each circle they were assigned at the beginning of class. Record their answers in a table displayed for all to see and discuss:

- “How many times larger is the diameter?”
- “Does the area increases by the same factor?”
- “Is the relationship between the diameter and area of a circle a proportional relationship? How do you know?”

Draw arrows with the scale factors to the left side of the table to illustrate the relationship between the diameters. Draw arrows on the right side of the table and label them with the factor the area is increasing by, such as “ $\cdot 64$ ” or just write “ $\cdot 8$ ”.

	diameter (cm)	area of circle (cm ²)	
	2	3.1415927	
$\cdot 8$	16	201.0619328	$\cdot 64$
$\cdot 4$	3	7.068583575	$\cdot 16$
$\cdot 12$	12	113.0973372	$\cdot 9$
$\cdot 4$	4	12.5663708	$\cdot 25$
$\cdot 20$	20	314.15927	$\cdot 100$

7.4 Areas of Two Circles

Cool Down: 5 minutes

Addressing

- 7.G.B.4

Anticipated Misconceptions

If students think that the diameter and area of a circle are proportional, they will likely choose C because $20 \cdot 3 = 60$ and $300 \cdot 3 = 900$.

Student Task Statement

- Circle A has a diameter of approximately 20 inches and an area of 300 in^2 .
- Circle B has a diameter of approximately 60 inches.

Which of these could be the area of Circle B? Explain your reasoning.

1. About 100 in^2
2. About 300 in^2
3. About 900 in^2
4. About $2,700 \text{ in}^2$

Student Response

D. About $2,700 \text{ in}^2$. The diameter of Circle B is 3 times bigger than the diameter of Circle A, so the area of Circle B is larger than the area of Circle A. The pattern shows that the area grew quickly, so

900 is probably not large enough. The radius of Circle B is 30 inches, so the area is about $3 \cdot 30^2 \text{ in}^2$ (and is definitely more than 30^2 because a square of side 30 inches fits inside the circle with a lot of space left).

Student Lesson Summary

The circumference C of a circle is proportional to the diameter d , and we can write this relationship as $C = \pi d$. The circumference is also proportional to the radius of the circle, and the constant of proportionality is $2 \cdot \pi$ because the diameter is twice as long as the radius. However, the **area of a circle** is *not* proportional to the diameter (or the radius).

The area of a circle with radius r is a little more than 3 times the area of a square with side r so the area of a circle of radius r is approximately $3r^2$. We saw earlier that the circumference of a circle of radius r is $2\pi r$. If we write C for the circumference of a circle, this proportional relationship can be written $C = 2\pi r$.

The area A of a circle with radius r is approximately $3r^2$. Unlike the circumference, the area is not proportional to the radius because $3r^2$ cannot be written in the form kr for a number k . We will investigate and refine the relationship between the area and the radius of a circle in future lessons.

Glossary

- area of a circle

Lesson 7 Practice Problems

Problem 1

Statement

The x -axis of each graph has the diameter of a circle in meters. Label the y -axis on each graph with the appropriate measurement of a circle:

radius (m), circumference (m), or area (m^2).

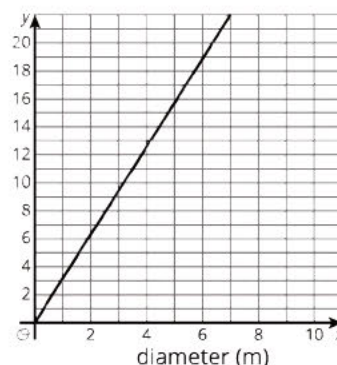
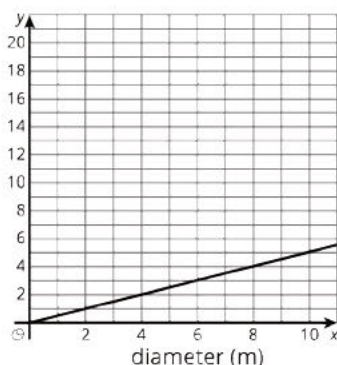
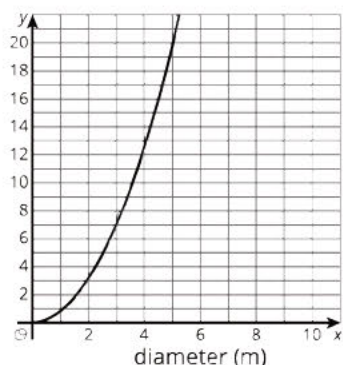

Solution

The first graph shows the relationship between the diameter and area of a circle, because it is not a proportional relationship. The second graph shows the relationship between the diameter and the radius, because it is proportional and the constant of proportionality is $\frac{1}{2}$. The third graph shows the relationship between the diameter and the circumference, because it is proportional and the constant of proportionality is π .

Problem 2

Statement

Circle A has area 500 in^2 . The diameter of circle B is three times the diameter of circle A. Estimate the area of circle B.

Solution

About $4,500 \text{ in}^2$. If the diameter is 3 times greater, the area must be 3^2 , or 9 times greater.

Problem 3

Statement

Lin's bike travels 100 meters when her wheels rotate 55 times. What is the circumference of her wheels?

Solution

About 1.82 meters because $100 \div 55 \approx 1.82$

(From Unit 3, Lesson 5.)

Problem 4

Statement

Priya drew a circle whose circumference is 25 cm. Clare drew a circle whose diameter is 3 times the diameter of Priya's circle. What is the circumference of Clare's circle?

Solution

75 cm

(From Unit 3, Lesson 3.)

Problem 5

Statement

- a. Here is a picture of two squares and a circle. Use the picture to explain why the area of this circle is more than 2 square units but less than 4 square units.

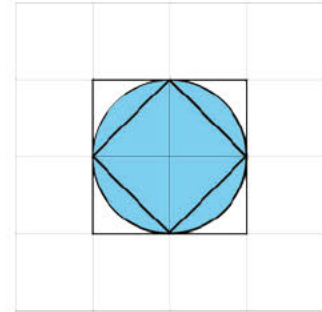

- b. Here is another picture of two squares and a circle. Use the picture to explain why the area of this circle is more than 18 square units and less than 36 square units.

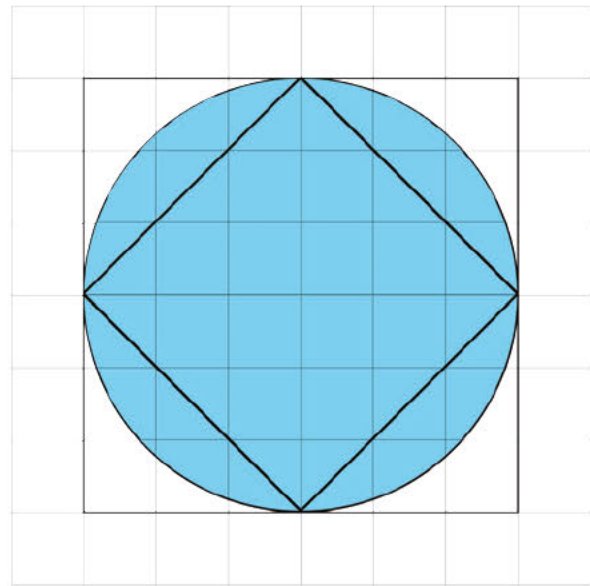

Solution

- a. The square inside the circle has an area of 2 square units because it is made of 4 triangles each with area $\frac{1}{2}$ square unit, and $\frac{4}{2} = 2$. The square outside the circle has an area of 4 square units, because $2^2 = 4$.
- b. The square inside the circle has an area of 18 square units because $12 + \frac{12}{2} = 18$ (the square inside the circle contains 12 full grid squares and 12 half grid squares). The square outside the circle has an area of 36 square units because $6^2 = 36$.

Problem 6

Statement

Point A is the center of the circle, and the length of CD is 15 centimeters. Find the circumference of this circle.

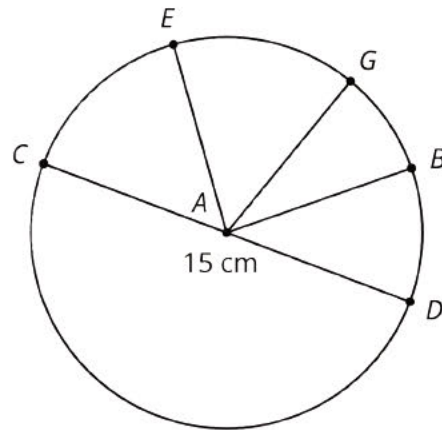

Solution

About 47 cm because $15 \cdot \pi \approx 47$

(From Unit 3, Lesson 3.)

Lesson 8: Relating Area to Circumference

Goals

- Generalize a process for finding the area of a circle, and justify (orally) why this can be abstracted as πr^2 .
- Show how a circle can be decomposed and rearranged to approximate a polygon, and justify (orally and in writing) that the area of this polygon is equal to half of the circle's circumference multiplied by its radius.

Learning Targets

- I can explain how the area of a circle and its circumference are related to each other.
- I know the formula for area of a circle.

Lesson Narrative

In the previous lesson, students found that it takes a little more than 3 squares with side lengths equal to the circle's radius to completely cover a circle. Students may have predicted that the area of a circle can be found by multiplying πr^2 . In this lesson students derive that relationship through informal dissection arguments. In the main activity they cut and rearrange a circle into a shape that approximates a parallelogram (MP 3). In an optional activity, they consider a different way to cut and rearrange a circle into a shape that approximates a triangle. In both arguments, one side of the polygon comes from the circumference of the circle, leading to the presence of π in the formula for the area of a circle.

Alignments

Addressing

- 7.G.B.4: Know the formulas for the area and circumference of a circle and use them to solve problems; give an informal derivation of the relationship between the circumference and area of a circle.

Instructional Routines

- MLR1: Stronger and Clearer Each Time
- MLR2: Collect and Display
- Notice and Wonder
- Think Pair Share

Required Materials

Blank paper

Cylindrical household items

Glue or glue sticks

Markers

Scissors

Required Preparation

You will need one cylindrical household item (like a can of soup) for each group of 2 students. The activity works best if the diameter of the item is between 3 and 5 inches.

If possible, it would be best to give each group 2 different colors of blank paper.

Student Learning Goals

Let's rearrange circles to calculate their areas.

8.1 Irrigating a Field

Warm Up: 5 minutes

The purpose of this activity is for students to estimate the area of a circle by comparing it to a surrounding square.

Addressing

- 7.G.B.4

Launch

Explain that some farms have circular fields because they use center-pivot irrigation. If desired, display these images to familiarize students with the context.

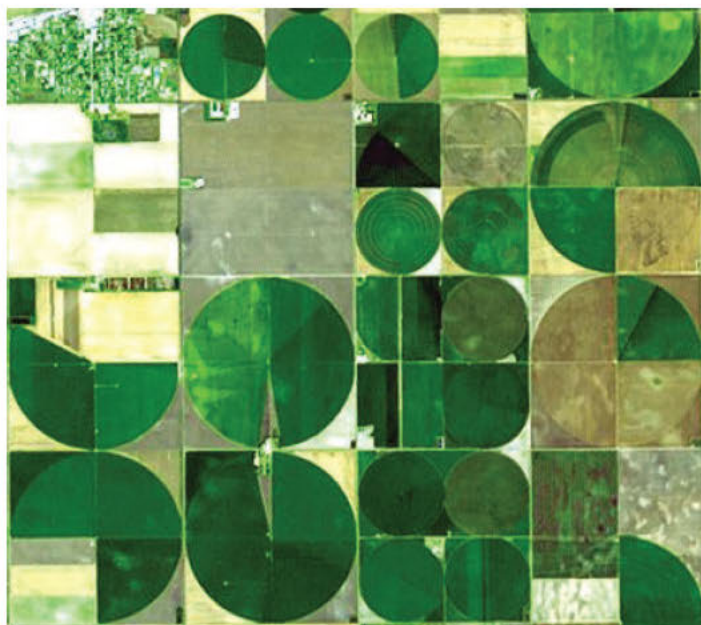



Provide quiet think time followed by whole-group discussion.

Anticipated Misconceptions

Students might think the answer should be $640,000 \text{ m}^2$ because that is the area of the square, not realizing that they are being asked to find the area of a circle. Ask them what shape is the region where the plants are growing.

Some students might incorrectly calculate the area of the square to be $6,400 \text{ m}^2$ and therefore estimate that the circle would be about $5,000 \text{ m}^2$.

Some students might try to use what they learned in the previous lessons about the relationship between the area of a circle and the area of a square with side length equal to the circle's radius. Point out that the question is asking for an estimate and answer choices all differ by a factor of 10.

Student Task Statement

A circular field is set into a square with an 800 m side length. Estimate the field's area.

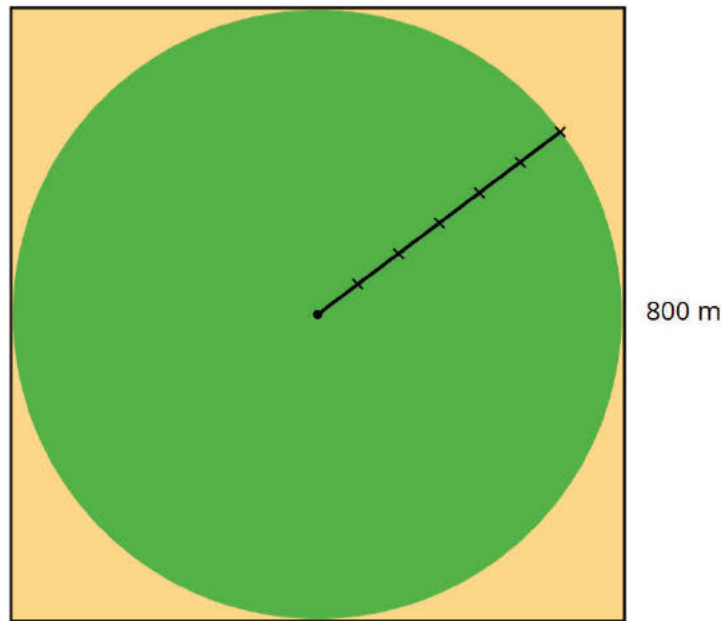

- About 5,000 m²
- About 50,000 m²
- About 500,000 m²
- About 5,000,000 m²
- About 50,000,000 m²

Student Response

C. The area of the circular field could be about 500,000 m² because it needs to be slightly less than the area of the square around it, which is 640,000 m², because $800 \cdot 800 = 640,000$.

Activity Synthesis

Discuss the estimation strategies students used to answer the question. Ask students what the area of the square is in square meters ($800 \cdot 800$, or 640,000). Ask them if the circle's area is greater than or less than the square's area (less). Then ask them to use the picture to determine the best estimate (500,000 since the circle is close in area to the square).

8.2 Making a Polygon out of a Circle

20 minutes

The purpose of this activity is for students to use what they know about finding the area of a parallelogram to develop the formula for the area of a circle. This activity builds on the work students did in grade 6 when cutting and rearranging shapes in order to calculate their areas. In this activity, students cut and rearrange parts of a circle to approximate a parallelogram. They see

that the area of the parallelogram would be calculated by multiplying half of the circle's circumference times its radius. Since students are not familiar with the process of writing proofs, it is necessary to walk them through writing the justification that uses the formula for the area of the parallelogram to develop the formula for the area of the circle.

The construction in this activity shows that the constructed parallelogram has a height at most the radius of the circle and a base at most half the circumference of the circle. Establishing equality is beyond grade level and will be addressed again in high school.

The process used to decompose the circle and recompose it into a shape resembling a parallelogram is a good example of MP8. The pie shaped wedges are successively cut in half and rearranged. Each time, the sides of the shape look more like line segments.

Watch for students who identify that the rearranged circle pieces resemble a parallelogram as the pieces get smaller. Also watch for how they estimate the width and height of this parallelogram and invite them to share during the discussion.

Addressing

- 7.G.B.4

Instructional Routines

- MLR2: Collect and Display

Launch

Arrange students in groups of 2. Each group needs a circular object, with a diameter between 3 and 5 inches, and a thick marker with which to trace it. Also provide each group a sheet of white paper, a sheet of colored paper, a pair of scissors, and glue or tape. Remind students that in the past they decomposed and rearranged a shape to figure out its area. Demonstrate how to do the first 4 steps of the activity, and invite students to follow along with your example. Ask how the area of the new shape differs from that of the circle. Solicit some ideas on what the new shape resembles and how the area of such a shape could be approximated. Without resolving this, ask students to continue the process.

Support for Students with Disabilities

Engagement: Develop Effort and Persistence. Provide prompts, reminders, guides, rubrics, or checklists that focus on increasing the length of on-task orientation in the face of distractions. For example, provide students with a task checklist which makes all the required components of the visual display explicit.

Supports accessibility for: Attention; Social-emotional skills

Support for English Language Learners

Conversing, Reading: MLR2 Collect and Display. As students work in groups to make sense of the shapes glued on the paper, circulate and listen to the language students use as they compare the shapes and discuss how to find the area of the shape that resembles a parallelogram. Write down the words and phrases students use to explain why the areas of both shapes are equal and why the area of the shape is half of the circumference multiplied by the radius. As students review the language collected in the visual display, encourage students to clarify the meaning of a word or phrase. For example, a phrase such as “the base is half of the circle” can be clarified with the phrase, “the base of the parallelogram is half of the circumference of the circle.” A phrase such as, “the height is the radius” can be clarified with the phrase, “the height of the parallelogram is equal to the radius of the circle.” This routine will provide feedback to students in a way that supports sense-making while simultaneously increasing meta-awareness of language.

Design Principle(s): Support sense-making; Maximize meta-awareness

Anticipated Misconceptions

Students might not fold the wedges accurately or make a straight cut. Remind them that the halves must be equal.

Student Task Statement

Your teacher will give you a circular object, a marker, and two pieces of paper of different colors.

Follow these instructions to create a visual display:

1. Using a thick marker, trace your circle in two separate places on the same piece of paper.
2. Cut out both circles, cutting around the marker line.
3. Fold and cut one of the circles into fourths.
4. Arrange the fourths so that straight sides are next to each other, but the curved edges are alternately on top and on bottom. Pause here so your teacher can review your work.
5. Fold and cut the fourths in half to make eighths. Arrange the eighths next to each other, like you did with the fourths.
6. If your pieces are still large enough, repeat the previous step to make sixteenths.
7. Glue the remaining circle and the new shape onto a piece of paper that is a different color.

After you finish gluing your shapes, answer the following questions.

1. How do the areas of the two shapes compare?
2. What polygon does the shape made of the circle pieces most resemble?
3. How could you find the area of this polygon?

Student Response

1. - 7. The shapes shown here, but without anything labeled.

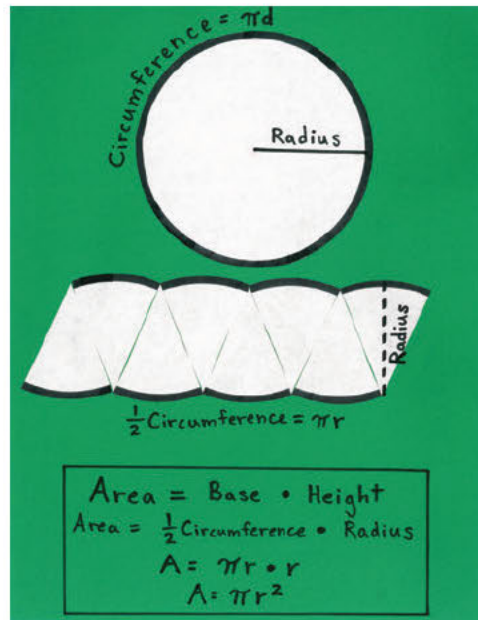

1. They are equal.
2. It is like a parallelogram but with a squiggly top and bottom.
3. Multiply base times height.

Activity Synthesis

Ask students which polygon resembles the shape they constructed of circle pieces and how they know. (A parallelogram or rectangle)

For a dynamic visualization, see <http://ggbm.at/RUqSMrjn>, created in GeoGebra by [Malin Christersson](#), or display this image.

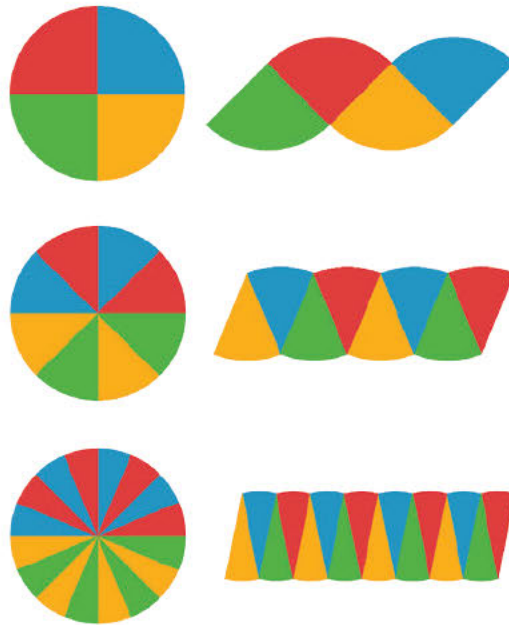

Ask, “If we could continue cutting the wedges in half, how would that affect the new shape?” (It would look even more like a parallelogram or rectangle. The bumpy top and bottom straighten out, and the slanted height becomes more vertical.)

Note that we are going to refer to the bumpy parallelogram-ish shape as the “parallelogram” (in quotes). Ask students to describe comparisons we can make between the measurements in the circle and the “parallelogram.” Record and display these ideas for all to see. It may be helpful to write over the actual images themselves. Students should notice the following measurements, but if they do not, prompt them to look for them:

- The base of the “parallelogram” is approximately equal to half of the circle’s circumference.
- The height of the “parallelogram” is approximately equal to the radius of the circle.
- The areas of the 2 shapes are equal.

Tell students to label these measurements on their visual display:

- “Circumference = πd ” around the circle
- “ $\frac{1}{2}$ Circumference = πr ” at the base of the “parallelogram”
- “Radius” on the radius of the circle (needs to be drawn in)
- “Radius” on the height of the “parallelogram” (needs to be drawn in)

If students struggle to understand these relationships through the abstract variables, consider measuring your example circle and using the numerical measurements to talk about these relationships.

Ask students to discuss the different ways we can calculate the area of the “parallelogram.” Students should share the following ways:

- Area = Base • Height
- Area = $\frac{1}{2}$ Circumference • Radius
- $A = \pi r \cdot r$
- $A = \pi r^2$

Tell students to record these ideas on their visual display. Display student work for all to see. If students do not bring up one of these ideas, make it explicit in the discussion.

8.3 Making Another Polygon out of a Circle

Optional: 10 minutes (there is a digital version of this activity)

The purpose of this activity is for students to consider a different way to cut and reassemble a circle into something resembling a polygon in order to calculate its area. This time the polygon is a triangle, but the area of the circle can still be found by multiplying $\frac{1}{2}$ times the circumference times the radius.

In the previous activity, students had experience following along as the teacher developed the justification. This time give students the opportunity to write their own justification for the area of a circle. As students work, monitor and select students who have clear, but different, explanations to share during the whole-group discussion. In particular, select students who use the following steps:

- Area = $\frac{1}{2} \cdot \text{base} \cdot \text{height}$
- Area = $\frac{1}{2} \cdot \text{circumference} \cdot \text{radius}$
- Area = $\frac{1}{2} \cdot (\pi d) \cdot r$
- Area = $\pi r \cdot r$
- Area = πr^2

If the bands making up the circle really did not stretch, then they would not form rectangles when they are unwound because the circumference of the inner circle is not the same as the circumference of the outer circle in each band. A rectangle is an appropriate approximation for the shape in terms of calculating its area.

Addressing

- 7.G.B.4

Instructional Routines

- MLR1: Stronger and Clearer Each Time

- Think Pair Share

Launch

Give students quiet work time followed by partner and whole-class discussion.

Support for Students with Disabilities

Representation: Internalize Comprehension. Activate or supply background knowledge about finding the area of triangles and circles. Allow students to use calculators to ensure inclusive participation in the activity.

Supports accessibility for: Memory; Conceptual processing

Anticipated Misconceptions

If students struggle to imagine the circle and how it is cut and rearranged, suggest a familiar material for the rings that bends but does not stretch (for example, a cord or chain).

Student Task Statement

Imagine a circle made of rings that can bend, but not stretch.



A circle is made of rings.



The rings are unrolled.



The circle has been made into a new shape.

1. What polygon does the new shape resemble?
2. How does the area of the polygon compare to the area of the circle?
3. How can you find the area of the polygon?
4. Show, in detailed steps, how you could find the polygon's area in terms of the circle's measurements. Show your thinking. Organize it so it can be followed by others.
5. After you finish, trade papers with a partner and check each other's work. If you disagree, work to reach an agreement. Discuss:
 - Do you agree or disagree with each step?
 - Is there a way to make the explanation clearer?
6. Return your partner's work, and revise your explanation based on the feedback you received.

Student Response

1. A triangle

2. The areas of the shapes are equal.
3. It looks like a triangle, so the area can be found with the formula $\text{Area} = \frac{1}{2} \cdot \text{base} \cdot \text{height}$.
4. The base of the “triangle” has length equal to the circumference of the circle, while its height is the radius of the circle. So:
 - $\text{Area} = \frac{1}{2} \cdot \text{circumference} \cdot \text{radius}$
 - $\text{Area} = \frac{1}{2} \cdot \pi d \cdot r$
 - $\text{Area} = \pi r \cdot r$
 - $\text{Area} = \pi r^2$

Activity Synthesis

Ask selected students to explain their steps for finding the area in terms of the circle’s measures. Ask the class whether they agree, disagree, or have questions after each student shares their reasoning.

Support for English Language Learners

Writing, Speaking, Listening: MLR1 Stronger and Clearer Each Time. After students have the opportunity to think about how to find the area of the triangle in terms of the circle’s measurements, ask students to write a brief explanation of their process. As students prepare their explanation, look for students who state that the area of the shape that resembles a triangle is half of the circumference multiplied by the radius of the circle. Ask each student to meet with 2–3 other partners for feedback. Provide students with prompts for feedback that will help them strengthen their ideas and clarify their language (e.g., “Can you explain how...,” “You should expand on...,” etc.). Students can borrow ideas and language from each partner to refine and clarify their original explanation. This will help students revise and refine both their ideas and their verbal and written output.

Design Principle(s): Optimize output (for explanation); Maximize meta-awareness

8.4 Tiling a Table

5 minutes

The purpose of this activity is for students to apply the formula for area of a circle to solve a problem in context. The diameter of the circle is given, so students must first determine the radius.

Addressing

- 7.G.B.4

Instructional Routines

- Notice and Wonder

Launch

Display this image of table top for all to see. Ask students, “What do you notice? What do you wonder?”

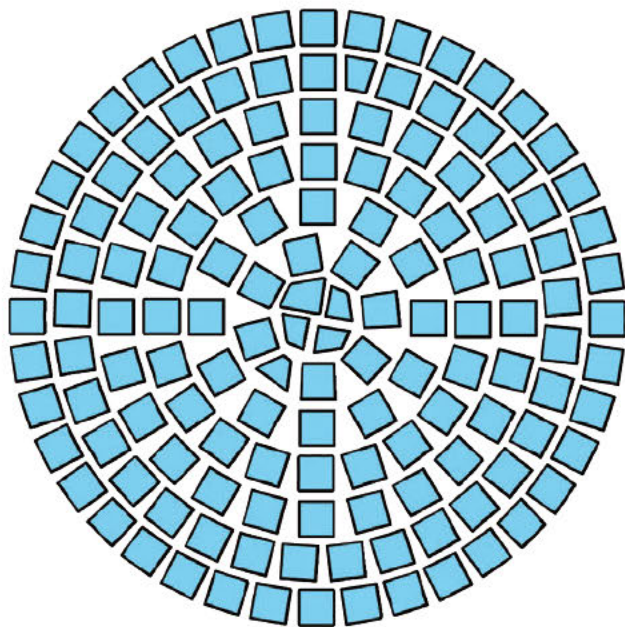

Quiet work time followed by a whole-class discussion.

Anticipated Misconceptions

Students may square the diameter, forgetting that they need to determine the radius first.

Student Task Statement

Elena wants to tile the top of a circular table. The diameter of the table top is 28 inches. What is its area?

Student Response

The area of the circular table is about 615 in^2 , because the diameter 28 in gives a radius of 14 in, and $\pi \cdot 14^2 \approx 615$.

Are You Ready for More?

A box contains 20 square tiles that are 2 inches on each side. How many boxes of tiles will Elena need to tile the table?

Student Response

$615 \div 20 = 30.75$. She would definitely have enough tiles from 8 boxes, and 7 boxes would probably be enough because of the space left in between the tiles for grout. It might be necessary to cut some of the tiles, especially near the boundary, so that they don't hang over the edge of the table.

Activity Synthesis

Invite students to share their strategies for finding the area of the tabletop. After 3 students have shared their strategies, ask the class what formula all of the students used for finding the area of a circle. Record and display this formula, $A = \pi r^2$, for all to see. Here, A is the area of the circle, and r is the radius of the circle.

Support for Students with Disabilities

Engagement: Develop Effort and Persistence. Encourage and support opportunities for peer interactions. Prior to the whole-class discussion, invite students to share their work with a partner. Display sentence frames to support student conversation such as: "First, I ____ because....", "I noticed ____ so I....", "Why did you...?", and "I agree/disagree because...."

Supports accessibility for: Language; Social-emotional skills

Lesson Synthesis

The main ideas are:

- We can find the area of a circle if we know the radius or the diameter.
- We know that the radius is half the length of the diameter.
- The formula for finding area of a circle is $A = \pi r^2$.

Discussion Questions:

- How would you find the area of a circle with a radius of 10? (Multiply π times 100, because $10^2 = 100$.)
- How would you find the area of a circle with a diameter of 10? (Multiply π times 25, because $10 \div 2 = 5$ and $5^2 = 25$.)

8.5 A Circumference of 44

Cool Down: 5 minutes

Addressing

- 7.G.B.4

Anticipated Misconceptions

Since the answers to questions 2 and 3 are dependent on the answer to question 1, check that students have accurately determined the diameter, and if necessary, remind them that since circumference is a little more than 3 times as long as the diameter, then the diameter is a little less than $\frac{1}{3}$ of the circumference.

Student Task Statement

A circle's circumference is approximately 44 cm. Complete each statement using one of these values:

7, 11, 14, 22, 88, 138, 154, 196, 380, 616.

1. The circle's diameter is approximately _____ cm.
2. The circle's radius is approximately _____ cm.
3. The circle's area is approximately _____ cm^2 .

Student Response

1. 14
2. 7
3. 154

Student Lesson Summary

If C is a circle's circumference and r is its radius, then $C = 2\pi r$. The area of a circle can be found by taking the product of half the circumference and the radius.

If A is the area of the circle, this gives the equation:

$$A = \frac{1}{2}(2\pi r) \cdot r$$

This equation can be rewritten as:

$$A = \pi r^2$$

(Remember that when we have $r \cdot r$ we can write r^2 and we can say " r squared.")

This means that if we know the radius, we can find the area. For example, if a circle has radius 10 cm, then the area is about $(3.14) \cdot 100$ which is 314 cm^2 .

If we know the diameter, we can figure out the radius, and then we can find the area. For example, if a circle has a diameter of 30 ft, then the radius is 15 ft, and the area is about $(3.14) \cdot 225$ which is approximately 707 ft^2 .

Glossary

- squared

Lesson 8 Practice Problems

Problem 1

Statement

The picture shows a circle divided into 8 equal wedges which are rearranged.

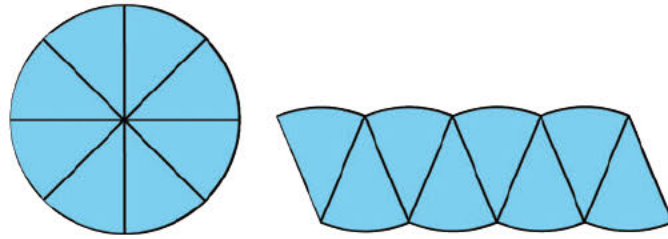

The radius of the circle is r and its circumference is $2\pi r$. How does the picture help to explain why the area of the circle is πr^2 ?

Solution

The rearranged shape looks more and more like a rectangle as the circle is cut into more pieces. The length of the rectangle is about half of the circumference of the circle or πr , and its height is roughly the radius r . So the area of the rectangle (and of the circle) is πr^2 .

Problem 2

Statement

A circle's circumference is approximately 76 cm. Estimate the radius, diameter, and area of the circle.

Solution

The radius is approximately 12 cm. The diameter is approximately 24 cm. The area is approximately 460 cm^2 .

Problem 3

Statement

Jada paints a circular table that has a diameter of 37 inches. What is the area of the table?

Solution

About $1,075 \text{ in}^2$

Problem 4

Statement

The Carousel on the National Mall has 4 rings of horses. Kiran is riding on the inner ring, which has a radius of 9 feet. Mai is riding on the outer ring, which is 8 feet farther out from the center than the inner ring is.

- In one rotation of the carousel, how much farther does Mai travel than Kiran?

- b. One rotation of the carousel takes 12 seconds. How much faster does Mai travel than Kiran?

Solution

- a. about $106.8 - 56.5$, or 50.3 feet farther
b. about $50.3 \div 12$, or 4.2 feet per second faster

(From Unit 3, Lesson 4.)

Problem 5

Statement

Here are the diameters of four coins:

coin	penny	nickel	dime	quarter
diameter	1.9 cm	2.1 cm	1.8 cm	2.4 cm

- a. A coin rolls a distance of 33 cm in 5 rotations. Which coin is it?
b. A quarter makes 8 rotations. How far did it roll?
c. A dime rolls 41.8 cm. How many rotations did it make?

Solution

- a. Nickel because $33 \div 5 \div \pi \approx 2.1$
b. About 60.3 cm because $2.4 \cdot \pi \cdot 8 \approx 60.3$
c. About 7 because $41.8 \div \pi \div 1.8 \approx 7$

(From Unit 3, Lesson 5.)

Lesson 9: Applying Area of Circles

Goals

- Calculate the area of a shape that includes circular or semi-circular parts, and explain (orally and in writing) the solution method.
- Comprehend and generate expressions in terms of π to express exact measurements related to a circle.

Learning Targets

- I can calculate the area of more complicated shapes that include fractions of circles.
- I can write exact answers in terms of π .

Lesson Narrative

In previous lessons, students estimated the area of circles on a grid and explored the relationship between the circumference and the area of a circle to see that $A = \pi r^2$. In this lesson, students apply this formula to solve problems involving the area of circles as well as shapes made up of parts of circles (MP 1 and 2) and other shapes such as rectangles. These calculations require composition and decomposition recalling work from grade 6.

Also, in this lesson students are introduced to the idea of expressing exact answers in terms of π .

Alignments

Addressing

- 7.G.B.4: Know the formulas for the area and circumference of a circle and use them to solve problems; give an informal derivation of the relationship between the circumference and area of a circle.

Instructional Routines

- Anticipate, Monitor, Select, Sequence, Connect
- MLR1: Stronger and Clearer Each Time
- MLR7: Compare and Connect
- Think Pair Share

Required Materials

Four-function calculators

Required Preparation

It is recommended that four-function calculators be made available to take the focus off computation.

Student Learning Goals

Let's find the areas of shapes made up of circles.

9.1 Still Irrigating the Field

Warm Up: 5 minutes

The purpose of this activity is for students to calculate a more exact answer to a problem from the previous lesson in which they estimated the area. Each answer choice listed results from using a different approximation of π .

Addressing

- 7.G.B.4

Launch

Remind students that the circular field is enclosed by a square that is 800 m on a side. If students ask what approximation they should use for π , tell them they can choose.

Give students 2 minutes of quiet work time followed by a whole-class discussion.

Student Task Statement

The area of this field is about $500,000 \text{ m}^2$. What is the field's area to the nearest square meter? Assume that the side lengths of the square are exactly 800 m.

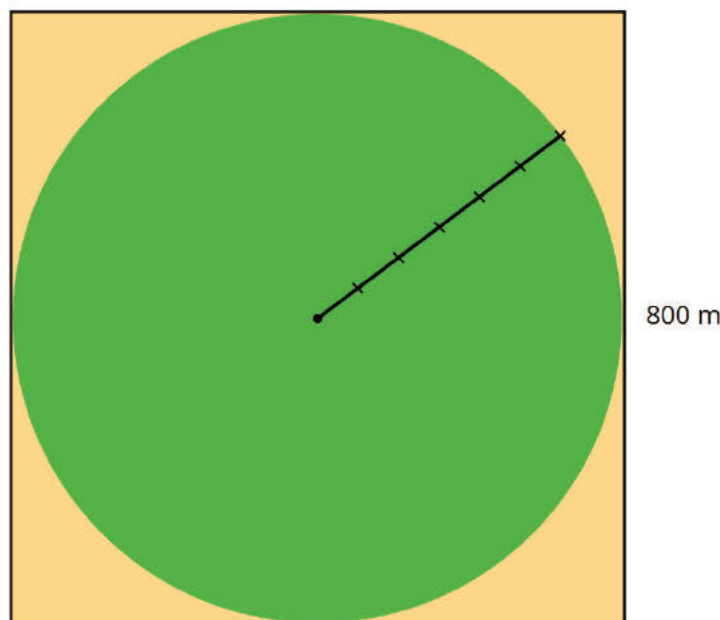

- $502,400 \text{ m}^2$
- $502,640 \text{ m}^2$
- $502,655 \text{ m}^2$

- $502,656 \text{ m}^2$
- $502,857 \text{ m}^2$

Student Response

Answers vary based on the chosen approximation for π . The most accurate answer is C, $502,655 \text{ m}^2$.

Activity Synthesis

All the answer choices are possible, but because the radius of the circle is so large, using a more approximate value for π can lead to a noticeable rounding error.

- $3.14 \cdot 400^2 = 502,400$
- $3.1415 \cdot 400^2 = 502,640$
- $3.1415927 \cdot 400^2 \approx 502,655$
- $3.1416 \cdot 400^2 = 502,656$
- $\frac{22}{7} \cdot 400^2 \approx 502,857$

The most accurate answer, $502,655 \text{ m}^2$, comes from using at least 6 decimal places for π .

9.2 Comparing Areas Made of Circles

20 minutes

The purpose of this activity is for students to find the areas of regions involving different-sized circles and compare the strategies used. The first question introduces subtraction as a strategy to find the area around the outside of a circle. The second question introduces division to find the area of fractions of a circle.

Monitor for students who use different strategies for finding the area, including:

- Calculating 30.96 square units for Figure A, $4 \cdot 7.74$ for Figure B, and $9 \cdot 3.44$ for Figure C
- Realizing that all 3 figures end up being $144 - 113.04$ so their areas had to be equal
- Noticing that Figure B is composed of 4 scaled copies of Figure A, each with a scale factor of $\frac{1}{2}$ and therefore $\frac{1}{4}$ as much area. Figure C is composed of 9 scaled copies of Figure A, each with a scale factor of $\frac{1}{3}$ and therefore $\frac{1}{9}$ as much area. (If a student does not make this realization, it is *not* necessary for the teacher to bring it up during the discussion.)
- Calculating 8.28 square units for Figure D and 8.71 square units for Figure E
- Realizing that Figure D has 2 fewer squares and 2 more quarter-circles (which are smaller than the squares) so it must have a smaller area

The task affords an opportunity for students to engage in MP6. Some students may leave the area expressions in terms of π , but others may use an approximation for π . It is very important, particularly for the first problem, that they use the *same* approximation for π in all 3 figures. Otherwise they will end up with numerically different answers.

Addressing

- 7.G.B.4

Instructional Routines

- Anticipate, Monitor, Select, Sequence, Connect
- MLR1: Stronger and Clearer Each Time
- Think Pair Share

Launch

Arrange students in groups of 2. Display the image in the first question and ask students to make a prediction before calculating. Give 30 seconds of quiet think time before sharing with their partner. Give students quiet work time followed by a whole-class discussion.

Anticipated Misconceptions

In the first question, students may not know how to find the radius of the circles. Suggest having them cut off the shaded regions and rearrange them to show that the length of each side fits half way across the circle (marking the radius).

In the second question, students might benefit from cutting and rearranging the figures. Some students might assume, based on previous activities, that the areas of both figures are equal. However, Figure D has more pieces that are parts of a circle, and Figure E has more units that are a full square. Ask students whether the fourth of the circle has the same area as the square.

Student Task Statement

1. Each square has a side length of 12 units. Compare the areas of the shaded regions in the 3 figures. Which figure has the largest shaded region? Explain or show your reasoning.

A

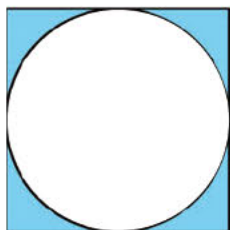

B

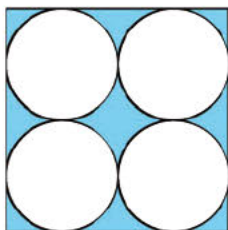

C

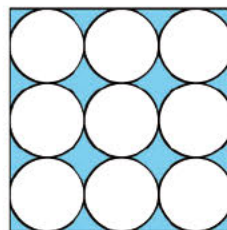

2. Each square in Figures D and E has a side length of 1 unit. Compare the area of the two figures. Which figure has more area? How much more? Explain or show your reasoning.

D

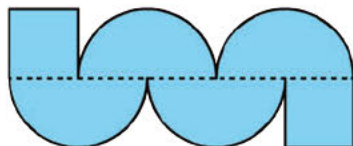

E

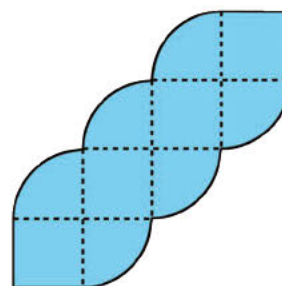

Student Response

- The areas of all 3 shaded regions are equal: about 30.96 square units ($144 - 36\pi$ square units). The area of the entire square is 144 square units, because $12 \cdot 12 = 144$. The area of the 1 large circle is approximately 113.04 square units, because $3.14 \cdot 6^2 = 113.04$. The area of the 4 medium circles is also 113.04 square units, because $3.14 \cdot 3^2 = 28.26$, and $28.26 \cdot 4 = 113.04$. The area of the 9 small circles is also 113.04 square units, because $3.14 \cdot 2^2 = 12.56$, and $12.56 \cdot 9 = 113.04$. The area of the shaded region in each figure is 30.96 square units, because $144 - 113.04 = 30.96$.
- Figure E's area is about 0.43 square units larger than Figure D's. Figure D consists of 2 squares and 4 half circles, giving it an area of about 8.28 square units, because $4 \cdot 1.57 + 2 = 8.28$. Figure E consists of 4 squares and 6 quarter circles, giving it an area of about 8.71 square units, because $6 \cdot 0.785 + 4 = 8.71$.

Are You Ready for More?

Which figure has a longer perimeter, Figure D or Figure E? How much longer?

Student Response

Figure D's perimeter is $\pi + 2$ units longer than Figure E's because $(4\pi + 6) - (3\pi + 4) = \pi + 2$.

Activity Synthesis

There are two main goals for this discussion: for students to notice ways to be more efficient when comparing the areas of the regions and to be introduced to expressing answers in terms of pi.

Display Figures A, B, and C for all to see. Ask selected students to share their reasoning. Sequence the strategies from most calculations to most efficient.

If there were selected students who determined the areas were equal before calculating, ask them to share how they could tell. If there were no selected students, ask the class how we could determine that the area of the shaded regions in Figures A, B, and C were equal before calculating the answer of 30.96.

Next, focus the discussion on leaving answers in terms of π for each figure. Explain to students that in Figure A, the radius of the circle is 6, so the area of the circular region is $\pi \cdot 6^2$. Instead of

multiplying by an approximation of π , we can express this answer as 36π . This is called answering *in terms of π* . Consider writing “ 36π ” inside the large circle of Figure A.

Discuss:

- In terms of π , what is the area of one of the circular regions in Figure B? (9π)
- What is the combined area of all four circles in Figure B? ($4 \cdot 9\pi$, or 36π)
- What is the area of one of the circular regions in Figure C? (4π)
- What is the combined area of all nine circles in Figure C? ($9 \cdot 4\pi$, or 36π)

Consider writing “ 9π ” and “ 4π ” inside some of the circles in Figures B and C. Explain that the area of the shaded region for each of these figures is $144 - 36\pi$.

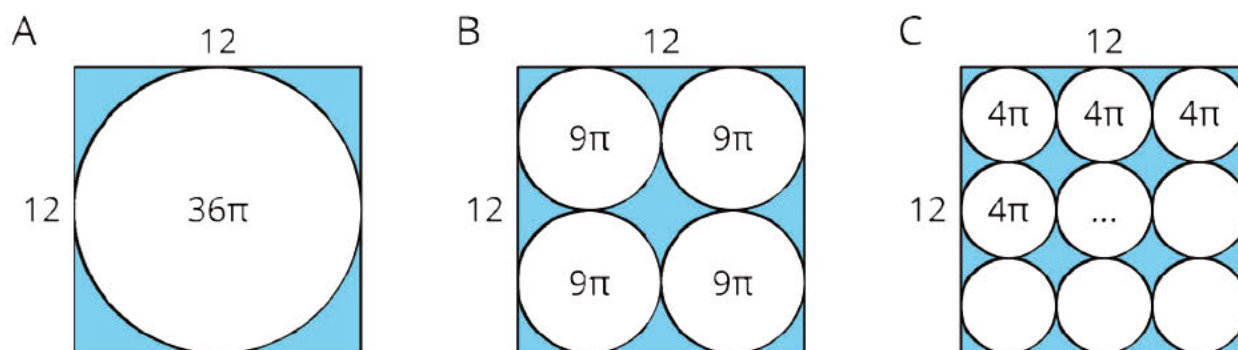

Discuss how students' strategies differed between the first problem (about Figures A, B, and C) and the second problem (about Figures D and E) and why.

Ask students to express the area of Figures D and E in terms of π . Record and display their answers of $2 + 2\pi$ and $4 + 1.5\pi$ for all to see. Ask students to discuss how they can tell Figure E's area is larger than Figure D's area when they are both written in terms of π .

Support for English Language Learners

Writing, Speaking, Listening: MLR1 Stronger and Clearer Each Time. After students have determined which figure has the largest shaded region, ask students to show their work and provide a brief explanation of their reasoning. Ask each student to meet with 2–3 other partners for feedback. Provide students with prompts for feedback that will help them strengthen their ideas and clarify their language (e.g., “How did you find the radius of each circle in the figure?”, “Why did you . . .?”, etc.). Students can borrow ideas and language from each partner to refine and clarify their original explanation. This will help students refine their own explanation and learn about different strategies to find area.

Design Principle(s): Optimize output (for explanation); Maximize meta-awareness

9.3 The Running Track Revisited

Optional: 10 minutes

Earlier in this lesson, students found the area of regions around circles and the area of fractions of circles in separate problems. In this activity, students combine these two strategies to find the area of a complex real-world object. Students engage in MP2 as they decide how to decompose the running track into measurable pieces and how to use the given information about the dimensions of the track to calculate areas.

Addressing

- 7.G.B.4

Instructional Routines

- MLR7: Compare and Connect

Launch

Arrange students in groups of 2. Give students 3–4 minutes of partner work time followed by small-group and whole-class discussions.

Support for Students with Disabilities

Action and Expression: Internalize Executive Functions. Provide students with a graphic organizer to organize the information provided in the problem and to structure their problem-solving strategy. The graphic organizer should include the prompts: “What do I need to find out?”, “What do I need to do?”, “How I solved the problem.”, and “How I know my answer is correct.”
Supports accessibility for: Language; Organization

Anticipated Misconceptions

Some students may think they can calculate the area of the running track by multiplying half of the perimeter times the radius, as if the shape were just a circle. Prompt them to see that they need to break the overall shape into rectangular and circular pieces.

Student Task Statement

The field inside a running track is made up of a rectangle 84.39 m long and 73 m wide, together with a half-circle at each end. The running lanes are 9.76 m wide all the way around.

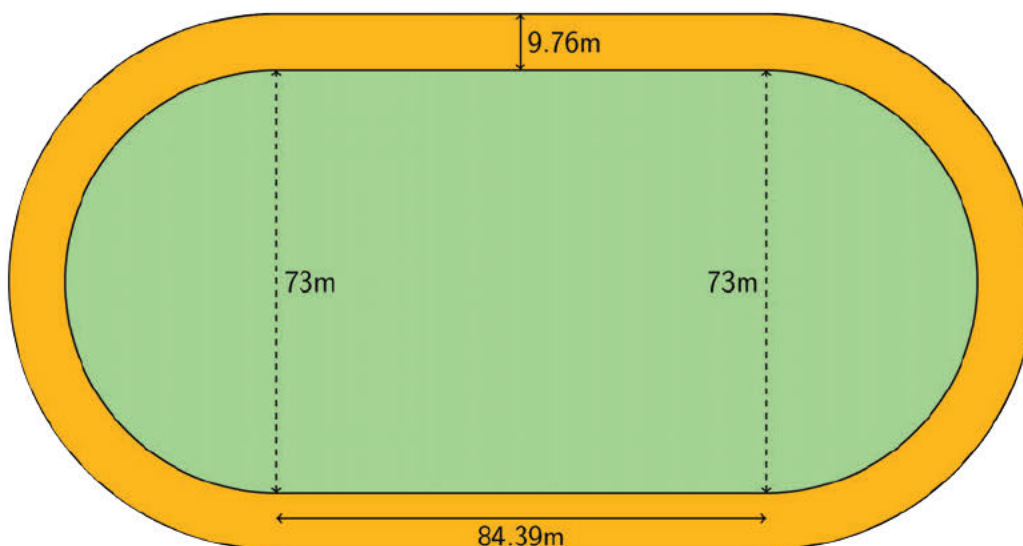

What is the area of the running track that goes around the field? Explain or show your reasoning.

Student Response

The area of the entire running track is $807.7376\pi + 823.6464$, or about $4,183.6 \text{ m}^2$. The area of the straight top and bottom of the running track are each 823.6464 m^2 because $84.39 \cdot 9.76 = 823.6464$. The left and right sides of the running track are half circles with a smaller half circle missing from the inside. The area of the inside circle is about $4,183.265 \text{ m}^2$ because $36.5^2 \cdot 3.14 = 4,183.265$. The area of the outside circle is about $6,719.561064 \text{ m}^2$ because $36.5 + 9.76 = 46.26$ and $46.26^2 \cdot 3.14 = 6,719.561064$. The area of each curved side of the running track is about $1,268.148032 \text{ m}^2$ because $(6,719.561064 - 4,183.265) \div 2 = 1,268.148032$. The area of the entire running track is about $4,183.6 \text{ m}^2$ because $2 \cdot 823.6464 + 2 \cdot 1,268.148032 = 4,183.588864$.

Activity Synthesis

Pair the groups of 2 to create groups of 4. Have students compare answers and explain their reasoning until they reach an agreement.

As a whole group, discuss how finding the area of the track in this activity was similar or different to solving the two area problems in the previous activity. Make sure to highlight these points:

- Like the first problem in the previous activity, finding the area of the track can be done by finding the area of the larger shape (the track and the field inside) and then taking away the area of the field inside.
- Like the second problem in the previous activity, there are semicircles whose area can be found by composing them to make a full circle or by taking half the area of the corresponding full circle.

Support for English Language Learners

Representing, Speaking, Listening: MLR7 Compare and Connect. Ask students to prepare a visual display that shows how they calculated the area of the running track that goes around the field, and look for students with different strategies for calculating the area of the curved parts of the track. As students investigate each other's work, ask students to share what worked well in a particular approach. During this discussion, listen for and amplify any comments that clarify that the curved parts of the running track are half circles with a smaller circle missing from the inside. Then encourage students to make connections between the quantities representing areas and the shapes in the diagram. Ask questions such as, "What does the quantity 6,719.561 represent in the diagram?" and "What does the quantity 4,183.265 represent in the diagram?" During this discussion, listen for and amplify language students use to reason that these quantities represent the areas of larger and smaller circles, respectively. This will foster students' meta-awareness and support constructive conversations as they compare strategies for finding the area of a complex real-world object.

Design Principle(s): Cultivate conversation; Maximize meta-awareness

Lesson Synthesis

Discussion Questions:

- What is the area, in terms of π , of a circle with a radius of 10? (100π , because $10^2 = 100$.)
- What is the area, in terms of π , of a circle with a diameter of 10? (25π , because $10 \div 2 = 5$ and $5^2 = 25$.)
- What is the area, in terms of π , of a half-circle with a diameter of 10? (12.5π , because $25 \div 2 = 12.5$.)

9.4 Area of an Arch

Cool Down: 5 minutes

This cool-down purposefully does not specify whether students should give an exact answer (in terms of pi) or use an approximation. This ambiguity provides an opportunity for teachers to assess whether students have internalized that leaving their answer in terms of pi is an acceptable way to express an answer when they aren't told what to round to or what approximation to use.

Addressing

- 7.G.B.4

Anticipated Misconceptions

Students may think the word side refers to the length of the outer sides in the block. Tell these students that side, in this context, refers to the face of the block they are given.

Students might correctly find the areas of the rectangle and the half-circle but add these values instead of subtracting.

Students might forget to divide the area of the circle by 2 to find the area of the half-circle.

Student Task Statement

Here is a picture that shows one side of a child's wooden block with a semicircle cut out at the bottom.

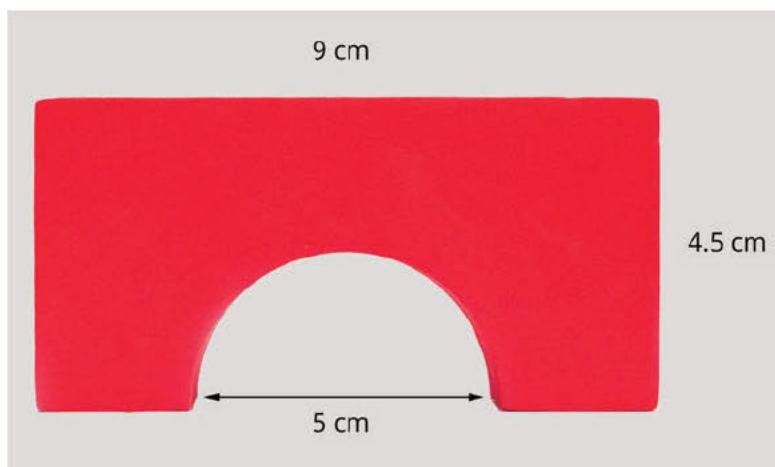

Find the area of the side. Explain or show your reasoning.

Student Response

The area of the side of the block is about 30.68 cm^2 . The area of the rectangle is $9 \cdot 4.5$, or 40.5 cm^2 . The area of a circle with a diameter of 5 cm is $6.25\pi \text{ cm}^2$. The front face of the wooden block is a rectangle missing half of circle with diameter 5 cm, so its area in cm^2 is $40.5 - 3.125\pi$ or about 30.68.

Student Lesson Summary

The relationship between A , the area of a circle, and r , its radius, is $A = \pi r^2$. We can use this to find the area of a circle if we know the radius. For example, if a circle has a radius of 10 cm, then the area is $\pi \cdot 10^2$ or $100\pi \text{ cm}^2$. We can also use the formula to find the radius of a circle if we know the area. For example, if a circle has an area of $49\pi \text{ m}^2$ then its radius is 7 m and its diameter is 14 m.

Sometimes instead of leaving π in expressions for the area, a numerical approximation can be helpful. For the examples above, a circle of radius 10 cm has area about 314 cm^2 . In a similar way, a circle with area 154 m^2 has radius about 7 m.

We can also figure out the area of a fraction of a circle. For example, the figure shows a circle divided into 3 pieces of equal area. The shaded part has an area of $\frac{1}{3}\pi r^2$.

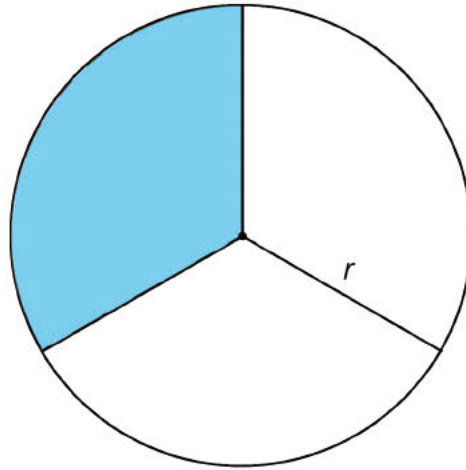

Lesson 9 Practice Problems

Problem 1

Statement

A circle with a 12-inch diameter is folded in half and then folded in half again. What is the area of the resulting shape?

Solution

$9\pi \text{ in}^2$, or about 28 in^2 , because $\frac{1}{4} \cdot 6^2 \pi = 9\pi$

Problem 2

Statement

Find the area of the shaded region. Express your answer in terms of π .

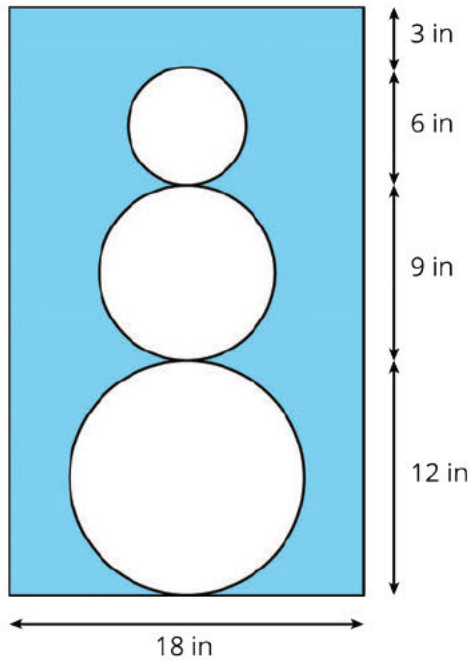

Solution

$540 - 65.25\pi \text{ in}^2$. Find the area of the rectangle by multiplying $18 \cdot 30 = 540$. Find the radii of the circles, square them, and add them together. $6^2 + 4.5^2 + 3^2 = 65.25$. Multiply 65.25 by π to get the total area of the circles. Subtract 65.25π from 540 to find the area of the shaded region.

Problem 3

Statement

The face of a clock has a circumference of 63 in. What is the area of the face of the clock?

Solution

About 316 in^2 . Divide 63 by π and by 2 to determine the radius of the clock. $63 \div 2 \div \pi \approx 10$. To find the area of the face of the clock multiply π by 10^2 .

(From Unit 3, Lesson 8.)

Problem 4

Statement

Which of these pairs of quantities are proportional to each other? For the quantities that are proportional, what is the constant of proportionality?

- Radius and diameter of a circle

- b. Radius and circumference of a circle
- c. Radius and area of a circle
- d. Diameter and circumference of a circle
- e. Diameter and area of a circle

Solution

- a. Yes. The diameter is twice the radius so the constant of proportionality is either 2 or $\frac{1}{2}$.
- b. Yes. The circumference is 2π times the radius so the constant of proportionality is either 2π or $\frac{1}{2\pi}$.
- c. No
- d. Yes. The circumference is π times the diameter so the constant of proportionality is either π or $\frac{1}{\pi}$.
- e. No

(From Unit 3, Lesson 7.)

Problem 5

Statement

Find the area of this shape in two different ways.

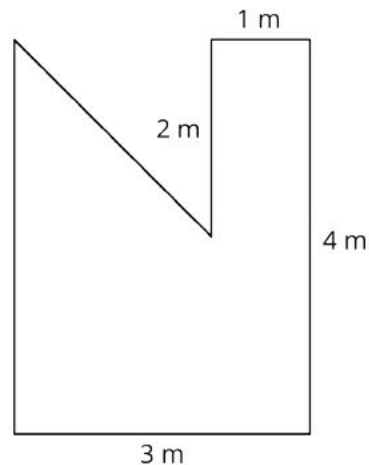

Solution

10 m^2 . Explanations vary. Sample responses:

- a. It is a rectangle of area 12 m^2 with a triangle of area 2 m^2 missing.

b. It is a rectangle of area 6 m^2 plus a rectangle of area 2 m^2 plus a triangle of area 2 m^2 .

(From Unit 3, Lesson 6.)

Problem 6

Statement

Elena and Jada both read at a constant rate, but Elena reads more slowly. For every 4 pages that Elena can read, Jada can read 5.

a. Complete the table.

pages read by Elena	pages read by Jada
4	5
1	
9	
e	
	15
	j

b. Here is an equation for the table: $j = 1.25e$. What does the 1.25 mean?

c. Write an equation for this relationship that starts $e = \dots$

Solution

a.

pages read by Elena	pages read by Jada
4	5
1	$\frac{5}{4}$ or 1.25
9	$\frac{45}{4}$ or 11.25
e	$\frac{5}{4}e$ or $1.25e$
12	15
$\frac{4}{5}j$ or $0.8j$	j

b. For every one page that Elena reads, Jada reads 1.25 pages.

c. $e = \frac{4}{5}j$ or $e = 0.8j$

(From Unit 2, Lesson 5.)

Section: Let's Put it to Work

Lesson 10: Distinguishing Circumference and Area

Goals

- Critique (orally and in writing) claims about the radius, diameter, circumference, or area of a circle in a real-world situation.
- Decide whether to calculate the circumference or area of a circle to solve a problem in a real-world situation, and justify (orally) the decision.
- Estimate measurements of a circle in a real-world situation, and explain (orally and in writing) the estimation strategy.

Learning Targets

- I can decide whether a situation about a circle has to do with area or circumference.
- I can use formulas for circumference and area of a circle to solve problems.

Lesson Narrative

Students have spent several lessons investigating circumference, and then several lessons investigating area, separately. In this lesson, both types of problems are mixed together so students have to distinguish which measurement is called for in each problem situation (MP 1 and 2). Also, in previous lessons students were always given one measurement of each circle, but in this lesson they must rely on their own estimations to solve the problems (MP 6). Students continue working with answers expressed in terms of π , which was introduced in the previous lesson.

Alignments

Addressing

- 7.G.B.4: Know the formulas for the area and circumference of a circle and use them to solve problems; give an informal derivation of the relationship between the circumference and area of a circle.

Instructional Routines

- Group Presentations
- MLR2: Collect and Display
- MLR7: Compare and Connect
- MLR8: Discussion Supports
- Take Turns

Required Materials

Pre-printed slips, cut from copies of the **blackline master**

Required Preparation

You will need the Card Sort: Circle Problems blackline master for this lesson. Prepare and cut one copy for every 2 students. These can be reused from one class to the next. If possible, copy each complete set of cards on a different color of paper, so that a stray card can quickly be put back.

Be prepared to explain or show images of any of the examples of circles in the sorting activity that may be unfamiliar to your students.

Student Learning Goals

Let's contrast circumference and area.

10.1 Filling the Plate

Warm Up: 5 minutes

This warm-up prompts students to apply what they have learned about finding the area of a circle to estimating the area of a circular plate in terms of a smaller circle. Students see a plate with a single cheese puff and from this information need to make a reasoned estimate for the number of cheese puffs that will cover the plate. As students discuss their estimates with a partner, monitor the discussions. Select students who use different estimation strategies to share during the discussion.

This activity was inspired by one created by Andrew Stadel. <http://www.estimated180.com/day-207.html>.

Addressing

- 7.G.B.4

Launch

Arrange students in groups of 2. Show them the picture of the plate with one cheese puff and ask them what they notice and wonder.



Let students share their observation and question with one another and invite a few students to share with the class. If the question “How many cheese puffs will fit on the plate” does not come up, ask if any one wondered how many cheese puffs can fit on the plate. Give students two minutes to make an estimate.

Student Task Statement

About how many cheese puffs can fit on the plate in a single layer? Be prepared to explain your reasoning.



Student Response

Answers vary. Sample response: The radius of the plate is about 7 cheese balls, so its area is about $3 \cdot 7^2$ times the area of a cheeseball. So about 150 cheeseballs should fit (as long as there is not too much space left between them).

Activity Synthesis

Invite selected students to share their estimates and any information in the image that informs their estimates. After each explanation, solicit questions from the class that could help the student clarify his or her reasoning. Record the estimates and strategies and display them for all to see.

10.2 Card Sort: Circle Problems

15 minutes

The purpose of this activity is for students to think about how circumference and area of circles apply to real-world situations. First, students sort slips based on whether the question is related to the circumference or area of a circle. Next, each group focuses on one of the questions (#1 through 5). They estimate appropriate measurements for the context, and use these measurements to calculate a reasonable answer (MP2). Questions 6 through 8 will be examined more closely in a future activity.

You will need the blackline master for this activity.

Addressing

- 7.G.B.4

Instructional Routines

- MLR2: Collect and Display
- Take Turns

Launch

Arrange students in groups of 2. Explain or show images of any of the contexts that may be unfamiliar to your students.

Distribute question slips. Give students 3–4 minutes of partner work time to sort the question slips. Pause to poll the class on how they sorted each card. After students have come to an agreement on the sorting, assign each group one card from #1–5 to investigate further. Give students quiet work time to make their estimates and calculations, followed by small-group and whole-class discussion.

Support for Students with Disabilities

Representation: Internalize Comprehension. Chunk this task into more manageable parts to differentiate the degree of difficulty or complexity by beginning with fewer cards. For example, give students a subset of the cards to start with, and introduce the remaining cards once students have completed their initial round of sorting.

Supports accessibility for: Conceptual processing; Organization

Support for English Language Learners

Conversing, Reading: MLR2 Collect and Display. As students sort the cards into two groups, write down the language students use to decide whether to use the circumference or area of the circle to answer the question. Sort the language into two columns labeled “circumference” and “area” of a circle. Listen for students who clarify that the circumference measures distance around a circle and uses linear units, while area measures the inside of a circle and uses square units. Display the language collected and encourage students to clarify the meaning of a word or phrase. For example, a phrase such as “We should use area because we want to know how big the pizza is” can be clarified by rephrasing it as “We should use area because we want to know how many square inches of cheese fit on the pizza.” This routine will provide feedback to students in a way that supports sense-making while simultaneously increasing meta-awareness of mathematical language.

Design Principle(s): Support sense-making; Maximize meta-awareness

Anticipated Misconceptions

If students are confused about the difference between circumference and area, remind them that circumference measures distance around a circle and uses linear units, while area measures the inside of a circle and uses square units.

Students might think they need to solve the problems on all 8 cards. Point out that the first question is only asking them to think about *how* they would solve the problems, not to do any actual calculations.

For the horse walker problem, students might not realize that they need to convert 1 mile to the same units as their estimated diameter, or that they need to divide by the circumference.

Student Task Statement

Your teacher will give you cards with questions about circles.

1. Sort the cards into two groups based on whether you would use the circumference or the area of the circle to answer the question. Pause here so your teacher can review your work.

2. Your teacher will assign you a card to examine more closely. What additional information would you need in order to answer the question on your card?
3. Estimate measurements for the circle on your card.
4. Use your estimates to calculate the answer to the question.

Student Response

1. Area: 1, 3, 4, 7; Circumference: 2, 5, 6, 8
2. For every card, knowing the radius or diameter of the circle would help solve the problem because the circumference and area can both be calculated from the radius or diameter. Additionally, for the Ferris wheel problem you would need to know the time it takes to go around the Ferris wheel once. For the pizza problem, you would need to know the number of slices the pizza is cut into (and that they are roughly the same size). For the horse walker problem, you would need to know how to convert 1 mile into a smaller unit of measure.
3. Answers vary. Possible solutions:
 - Question 1: A radius between 8 and 40 inches
 - Question 2: A diameter between 10 and 160 meters and about 1 to 30 minutes per rotation
 - Question 3: A radius between 5 and 25 yards
 - Question 4: A radius between 4 and 9 inches and 8 slices per pizza
 - Question 5: A diameter between 9 and 33 yards and 1,760 yards per mile
4. Answers vary. Possible solutions:
 - Question 1: Between 64π and 1600π in²
 - Question 2: From between 10π and 160π meters per minute (1 revolution per minute) to between $\frac{1}{3}\pi$ and $\frac{16}{3}\pi$ meters per minute (1 revolution per 30 minutes)
 - Question 3: Between 25π and 625π yd²
 - Question 4: Between 2π and $10\frac{1}{8}\pi$ in²
 - Question 5: Between $\frac{1760}{33\pi}$ and $\frac{1760}{9\pi}$ rotations

Activity Synthesis

The goal of this discussion is for students to articulate how they decide whether an answer is reasonable.

First, have the students who worked on the same question compare answers and strategies. Display these questions to guide their group discussions:

- Did you use the same units?

- How did you come up with your estimate for the size of the circle (radius or diameter)?
- Are your estimates very close? Are they reasonable?
- How did you calculate your answer to the question?
- Are your answers very close? Are they reasonable?

Next, invite students who have different answers to the same question to share their reasoning with the class. For each group, ask the rest of the class “Which of these answers do you think are reasonable? Why?” Make sure students understand that since estimates were called for, there is not one exact correct answer for each of these problems.

Some mistakes that could lead to an unreasonable answer include:

- Making too inaccurate of an initial estimate about the size of the circle
- Using the diameter as if it were the radius, or vice versa
- Using the wrong formula for circumference or area
- Forgetting to address an aspect of the question (such as finding the area of the entire pizza, not one slice)
- Labeling the units incorrectly, like using feet for a measure of area instead of square feet
- Reporting an answer with more decimal places than is reasonable given the level of precision of their initial estimates

If not mentioned by students, look for opportunities to bring these up, in preparation for a future activity in which students will analyze claims made about questions #6–8.

10.3 Visual Display of Circle Problem

Optional: 15 minutes

This activity asks students to create a visual display of the circle problem that they solved previously. They can practice explaining their reasoning more clearly on this display than they did in the previous activity. This gives them an opportunity to organize and record their information in a way that can be shared with others who worked on a different problem. The displays can also serve as a record of reasoning about circles which can be referred back to later in the year.

Addressing

- 7.G.B.4

Instructional Routines

- Group Presentations
- MLR7: Compare and Connect

Launch

Keep students in the same groups. Explain that they are going to create a visual display of the circle problem that they just worked on. Follow with discussion.

Support for Students with Disabilities

Engagement: Internalize Self Regulation. Provide a project checklist that chunks the various steps of the project into a set of manageable tasks.

Supports accessibility for: Organization; Attention

Student Task Statement

In the previous activity you estimated the answer to a question about circles.

Create a visual display that includes:

- The question you were answering
- A diagram of a circle labeled with your estimated measurements
- Your thinking, organized so that others can follow it
- Your answer, expressed in terms of π and also expressed as a decimal approximation

Student Response

Answers vary.

Activity Synthesis

Arrange for groups that are assigned the same problem to present their visual displays near one another. Give students a few minutes to visit the displays and to see the estimates others used to answer the question. Before students begin a gallery walk, ask them to be prepared to share a couple of observations about how their estimates and strategies are the same as or different from others'.

After the gallery walk, invite a couple of students to share their observations.

Support for English Language Learners

Representing, Speaking, Listening: MLR7 Compare and Connect. After groups have prepared a visual display that shows how they solved the circle problem on the card, arrange pairs of groups with different estimated measurements for the same problem. As groups investigate each other's work, ask them to share what worked well in a particular approach or what is especially clear in a particular diagram. Listen for and amplify any comments about what might make an approach or diagram more complete or easy to understand. Then encourage students to make connections between the radius and circumference or area of the circle. Listen for and amplify language students use to describe how their estimation for the radius affects the circumference or area of the circle. This will foster students' meta-awareness and support constructive conversations as they compare strategies for estimating the measurements of a circle and make connections between the radius and circumference or area of a circle. *Design Principle(s): Cultivate conversation; Maximize meta-awareness*

10.4 Analyzing Circle Claims

10 minutes

The purpose of this activity is for students to look more closely at the last three situations of the card sort activity (questions 6 through 8). They analyze and critique two claims about each situation, choosing or supplying the best response and explaining why (MP3). Students must recognize that in the first situation, one of the claims inaccurately estimates the size of the circle. In the second situation, one of the claims calculates the circumference instead of the area. In the third situation, both claims are inaccurate. One of the claims has the right number but uses square units, and the other has the right units but the wrong number.

As students work, monitor and select students who can explain why they agree with the correct claim and others who can explain why they disagree with the incorrect claim. For the third situation, select students who can explain why they disagree with both of the claims, even if they are unsure they are allowed to disagree with both.

Addressing

- 7.G.B.4

Instructional Routines

- MLR8: Discussion Supports

Launch

Keep students in same groups. Tell students they are going to look at how some other students solved the questions on cards 6, 7, and 8. For the first situation, make sure students realize we are referring to the type of merry-go-round at a playground (as pictured in their books or devices), not the larger type of carousel they might see at a fair.

Support for Students with Disabilities

Action and Expression: Develop Expression and Communication. To help get students started, display sentence frames such as: "I agree/disagree because....", "That could/couldn't be true because....", and "____'s idea reminds me of...."

Supports accessibility for: Language; Organization

Anticipated Misconceptions

Students might multiply by a decimal approximation, without recognizing that the answers in the claims are all given in terms of π .

Students might not realize there is an error with both of the claims in the third question.

Finally, students might not realize that they are supposed to analyze the reasonableness of the estimates, not just the mathematical correctness of the calculations.

Student Task Statement

Here are two students' answers for each question. Do you agree with either of them? Explain or show your reasoning.

1. How many feet are traveled by a person riding once around the merry-go-round?



- Clare says, "The radius of the merry-go-round is about 4 feet, so the distance around the edge is about 8π feet."
- Andre says, "The diameter of the merry-go-round is about 4 feet, so the distance around the edge is about 4π feet."

2. How much room is there to spread frosting on the cookie?



- Clare says "The radius of the cookie is about 3 centimeters, so the space for frosting is about 6π cm²."
- Andre says "The diameter of the cookie is about 3 inches, so the space for frosting is about 2.25π in²."

3. How far does the unicycle move when the wheel makes 5 full rotations?



- Clare says, "The diameter of the unicycle wheel is about 0.5 meters. In 5 complete rotations it will go about $\frac{5}{2}\pi \text{ m}^2$."
- Andre says, "I agree with Clare's estimate of the diameter, but that means the unicycle will go about $\frac{5}{4}\pi \text{ m}$."

Student Response

1. Clare's claim is more reasonable. Both people correctly calculated the circumference, given their estimated dimension for the circle. However, Andre's estimated diameter of 4 feet is too small, given the relative size of the child.
2. Andre's claim is more reasonable. Both estimated measurements for the circle are reasonable. However, Clare applied the circumference formula when the problem called for the area.
3. Neither claim is accurate. Clare has the correct number but answered with square units when the problem called for linear units. Andre has the correct units, but he squared the diameter when calculating the numerical value, as if he were using the radius to find the area. (It is also possible that Andre mistakenly used the radius instead of the diameter in the circumference formula.)

Are You Ready for More?

A goat (point G) is tied with a 6-foot rope to the corner of a shed. The floor of the shed is a square whose sides are each 3 feet long. The shed is closed and the goat can't go inside. The space all around the shed is flat, grassy, and the goat can't reach any other structures or objects. What is the area over which the goat can roam?

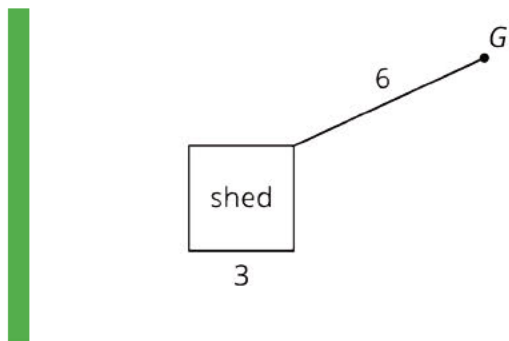

Student Response

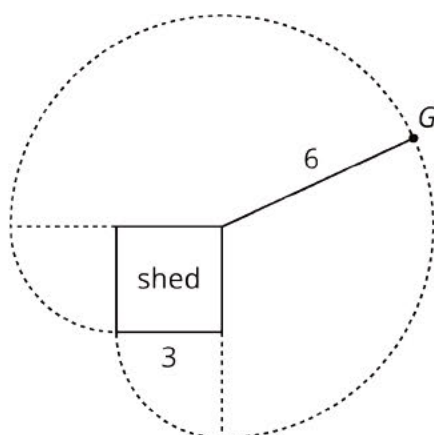

31.5π square feet (or approximately 99 square feet). The edge of the goat's roaming area is three quarters of a circle with radius 6 feet, until the rope gets caught on the corner of the shed, at which point the goat has two quarter-circles with radius 3 feet. Adding $\frac{3}{4}\pi \cdot 6^2$ and $2 \cdot \frac{1}{4}\pi \cdot 3^2$ gives 31.5π square feet.

Activity Synthesis

For each situation, poll the class on which person's claim is more accurate. Ask selected students to share their reasoning for each claim. If it does not come out during the discussion, point out that the formula for the area of a circle has a squared term and the units of the answer are square units, while the formula for the circumference does not have a squared term and the units of the answer are linear units.

Note: It is not possible to know for certain what Clare or Andre were thinking when they made their calculations. For example, it is likely in the second problem that Clare found the circumference of the cookie instead of its area, but it is not possible to know. Interpreting the work of others (to the extent possible) is an important skill and a fundamental part of MP3. A wide range of interpretations need to be considered, always keeping an open mind.

Support for English Language Learners

Speaking: MLR8 Discussion Supports. As students share whether they agree or disagree with each claim, press for details in students' reasoning by asking whether they should find the circumference or area of the circle in the problem. Also, ask students whether the estimates for the circumference or area are accurate given the estimated radius or diameter of the circle. Listen for and amplify comments that clarify when it is appropriate to use the formula for the circumference or area of a circle. Also, listen for language students use to describe Clare's or Andre's estimation errors or use of the incorrect formula. This will support rich and inclusive discussion about strategies for applying the formulas for the circumference and area of a circle to solve problems.

Design Principle(s): Support sense-making

Lesson Synthesis

Discussion Questions:

- When would we need to calculate the circumference of a circle?
- When would we need to calculate the area?
- What do you need to know to estimate or calculate the circumference of a circle? (radius or diameter)
- What do you need to know in order to estimate or calculate the area of a circle? (radius or diameter)

Consider posting the students' displays from the card sorting activity, grouped by circumference or area, so students can refer to them later.

10.5 Measuring a Circular Lawn

Cool Down: 5 minutes

Addressing

- 7.G.B.4

Student Task Statement

A circular lawn has a row of bricks around the edge. The diameter of the lawn is about 40 feet.

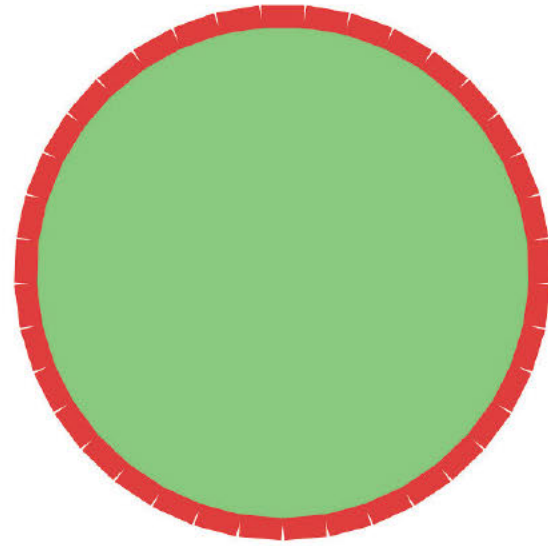

1. Which is the best estimate for the amount of grass in the lawn?
 - a. 125 feet
 - b. 125 square feet
 - c. 1,250 feet
 - d. 1,250 square feet
2. Which is the best estimate for the total length of the bricks?
 - a. 125 feet
 - b. 125 square feet
 - c. 1,250 feet
 - d. 1,250 square feet

Student Response

1. D. 1,250 square feet
2. A. 125 feet

Student Lesson Summary

Sometimes we need to find the circumference of a circle, and sometimes we need to find the area. Here are some examples of quantities related to the circumference of a circle:

- The length of a circular path.
- The distance a wheel will travel after one complete rotation.

- The length of a piece of rope coiled in a circle.

Here are some examples of quantities related to the area of a circle:

- The amount of land that is cultivated on a circular field.
- The amount of frosting needed to cover the top of a round cake.
- The number of tiles needed to cover a round table.

In both cases, the radius (or diameter) of the circle is all that is needed to make the calculation. The circumference of a circle with radius r is $2\pi r$ while its area is πr^2 . The circumference is measured in linear units (such as cm, in, km) while the area is measured in square units (such as cm^2 , in^2 , km^2).

Lesson 10 Practice Problems

Problem 1

Statement

For each problem, decide whether the circumference of the circle or the area of the circle is most useful for finding a solution. Explain your reasoning.

- a. A car's wheels spin at 1000 revolutions per minute. The diameter of the wheels is 23 inches. You want to know how fast the car is travelling.
- b. A circular kitchen table has a diameter of 60 inches. You want to know how much fabric is needed to cover the table top.
- c. A circular puzzle is 20 inches in diameter. All of the pieces are about the same size. You want to know about how many pieces there are in the puzzle.
- d. You want to know about how long it takes to walk around a circular pond.

Solution

- a. Circumference. The circumference of the wheels and the number of revolutions per minute tells you how far the car is traveling and this can be used to calculate the speed.
- b. Area. The fabric covers the surface of the table and it is this area that is needed.
- c. Area. The area of the puzzle divided by the area of a puzzle piece will give an estimate of the number of pieces.
- d. Circumference. You need to know the distance around the pond which is its circumference.

Problem 2

Statement

The city of Paris, France is completely contained within an almost circular road that goes around the edge. Use the map with its scale to:

- Estimate the circumference of Paris.
- Estimate the area of Paris.

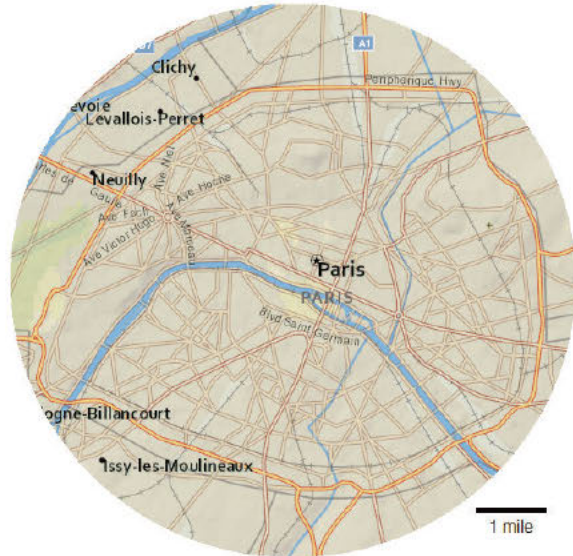

Solution

Answers vary. Sample response:

- About 6π miles (or about 20 miles)
- About $(3)^2\pi$ mi² (or about 30 mi²)

Problem 3

Statement

Here is a diagram of a softball field:

- a. About how long is the fence around the field?
- b. About how big is the outfield?

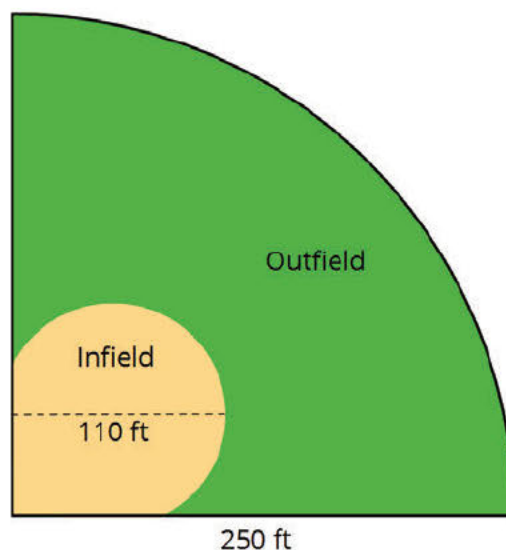

Solution

Answers vary. Sample responses:

- a. $500 + 125\pi$ (or about 893 ft): This estimate assumes that the curved boundary of the outfield is modeled by a quarter circle.
- b. $12,600\pi$ (or about $39,600 \text{ ft}^2$): The area of the full softball field, modeled by a quarter circle, is $\frac{1}{4} \cdot \pi \cdot 250^2$ or $15,625\pi$ square feet. The infield, which needs to be subtracted, has about the same area as a circle of radius 55 feet or $3,025\pi$ square feet. The difference is $12,600\pi$ square feet. Note that if we draw a circle with diameter 110 feet (where the 110 foot measurement is marked), it misses some of the lower left part of the infield but also contains some extra area below the softball field so this is a good estimate.

Problem 4

Statement

While in math class, Priya and Kiran come up with two ways of thinking about the proportional relationship shown in the table.

x	y
2	?
5	1750

Both students agree that they can solve the equation $5k = 1750$ to find the constant of proportionality.

- Priya says, "I can solve this equation by dividing 1750 by 5."
- Kiran says, "I can solve this equation by multiplying 1750 by $\frac{1}{5}$."

- a. What value of k would each student get using their own method?
- b. How are Priya and Kiran's approaches related?

- c. Explain how each student might approach solving the equation $\frac{2}{3}k = 50$.

Solution

- a. 350
- b. Priya divided each side of the equation by the same number. Seeing that 5 and k were multiplied in the equation, she used division to get k by itself. Meanwhile, Kiran multiplied by the reciprocal of 5.
- c. Priya divides by $\frac{2}{3}$ since k is being multiplied by $\frac{2}{3}$. Her equation is $k = 50 \div \frac{2}{3}$. Kiran multiplies by the reciprocal of $\frac{2}{3}$. His equation is $k = \frac{3}{2} \cdot 50$.

(From Unit 2, Lesson 5.)

Lesson 11: Stained-Glass Windows

Goals

- Apply circumference and area of circles to calculate the cost of a stained-glass window, and explain (orally and in writing) the solution method.
- Design a stained-glass window that could be built for a given dollar amount, and present (orally, in writing, and through other representations) a justification that it costs less than the limit.
- Make simplifying assumptions to solve problems about a stained-glass window.

Learning Targets

- I can apply my understanding of area and circumference of circles to solve more complicated problems.

Lesson Narrative

This culminating lesson is optional. In this lesson students work on several tasks that combine circumference and area ideas and computations. Students are given a design for a stained-glass window and the prices of the different components. They decide if it would be possible to produce the window for a certain amount of money. Students must make some assumptions about the shapes in the design and about how the different materials are sold.

The second task asks how scaling the window will affect the cost, bringing in ideas from a previous unit. Since measurements of both length and area are involved, the total cost does not simply increase by the scale factor nor by the square of the scale factor. In the last task, students invent their own design for a stained-glass window that could be produced given a cost constraint.

The series of tasks provides many opportunities to engage in different aspects of mathematical modeling (MP 4) and strategic use of tools (MP5).

Alignments

Addressing

- 7.EE.B.3: Solve multi-step real-life and mathematical problems posed with positive and negative rational numbers in any form (whole numbers, fractions, and decimals), using tools strategically. Apply properties of operations to calculate with numbers in any form; convert between forms as appropriate; and assess the reasonableness of answers using mental computation and estimation strategies. \$
- 7.G.A.1: Solve problems involving scale drawings of geometric figures, including computing actual lengths and areas from a scale drawing and reproducing a scale drawing at a different scale.

- 7.G.B.4: Know the formulas for the area and circumference of a circle and use them to solve problems; give an informal derivation of the relationship between the circumference and area of a circle.

Instructional Routines

- Group Presentations
- MLR3: Clarify, Critique, Correct
- MLR6: Three Reads
- MLR7: Compare and Connect
- MLR8: Discussion Supports
- Think Pair Share

Required Materials

Blank paper

Compasses

Four-function calculators

Geometry toolkits

For grade 6: tracing paper, graph paper, colored pencils, scissors, and an index card to use as a straightedge or to mark right angles.

For grades 7 and 8: everything in grade 6, plus a ruler and protractor. Clear protractors with no

holes and with radial lines printed on them are recommended.

Notes: (1) "Tracing paper" is easiest to use when it's a smaller size. Commercially-available "patty paper" is 5 inches by 5 inches and ideal for this. If using larger sheets of tracing paper, consider cutting them down for student use. (2) When compasses are required in grades 6-8 they are listed as a separate Required Material.

Required Preparation

Four-function calculators are optional but recommended to take the focus off computation.

Student Learning Goals

Let's use circumference and area to design stained-glass windows.

11.1 Cost of a Stained-Glass Window

Optional: 20 minutes

The purpose of this activity is for students to apply what they have learned about circles to solve a multi-step problem (MP1). Students find the area and perimeter of geometric figures whose boundaries are line segments and fractions of circles and use that information to calculate the cost of a project. The shape of the regions in the stained-glass window are left unspecified on purpose to give students an opportunity to engage in an important step of the mathematical modeling cycle - making simplifying assumptions (MP4). Assuming the curves in the design are arcs of a circle is not only reasonable, it is the most expedient assumption to make as well. As students work, prompt them to recognize that they are making this assumption and to make it explicit.

Another opportunity for mathematical modeling in this activity is to discuss if it is reasonable that a person only has to pay for the glass used in the final window and not for possible scraps of glass left over from cutting out the shapes. In reality, if they had to buy the glass at a store, the glass would likely come in square or rectangular sheets and they would need to buy more than they were going to use. If these issues come up, encourage students to keep note of the decisions they are making and to recognize that different choices would lead to different results.

Addressing

- 7.EE.B.3
- 7.G.B.4

Instructional Routines

- MLR6: Three Reads
- MLR8: Discussion Supports
- Think Pair Share

Launch

Arrange students in groups of 2. Give students 5 minutes of quiet work time followed by partner and whole-class discussions.

Support for Students with Disabilities

Action and Expression: Internalize Executive Functions. Provide students with a graphic organizer to organize the information provided in the problem and to structure their problem-solving strategy. The graphic organizer should include the prompts: “What do I need to find out?”, “What do I need to do?”, “How I solved the problem.”, and “How I know my answer is correct.”
Supports accessibility for: Language; Organization

Support for English Language Learners

Reading: MLR6 Three Reads. Use this routine to support reading comprehension of this problem, without solving it for students. In the first read, students read the problem with the goal of comprehending the situation (Students are designing a stained-glass window to hang in the school entryway.). In the second read, ask students to identify important quantities that can be counted or measured (the length and width of the window; the cost per square foot of colored glass; the cost per square foot of clear glass). In the third read, reveal the question, “Do they have enough money to cover the cost of making the window?” Ask students to brainstorm possible strategies to solve the problem. This will help students concentrate on making sense of the situation before rushing to a solution or method.

Design Principle(s): Support sense-making

Anticipated Misconceptions

Since there are multiple steps in solving this problem, some students may benefit from having their calculations checked along the way so one early error does not impact the final result.

Some students may struggle finding the diameter or radius lengths. Encourage these students to cut one individual panel, separate the clear glass from the colored glass, and rearrange the figures to see how to determine the length of the diameter and radius.

Student Task Statement

The students in art class are designing a stained-glass window to hang in the school entryway. The window will be 3 feet tall and 4 feet wide. Here is their design.

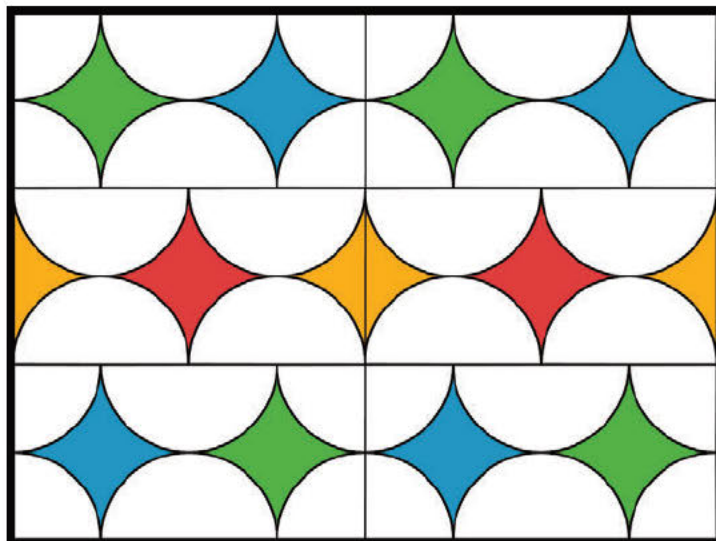

They have raised \$100 for the project. The colored glass costs \$5 per square foot and the clear glass costs \$2 per square foot. The material they need to join the pieces of glass together costs 10 cents per foot and the frame around the window costs \$4 per foot.

Do they have enough money to cover the cost of making the window?

Student Response

Yes, they need about \$93. Possible strategy:

Assume that the students only have to pay for the glass they use and not the scraps they cut away.

First, we need to find the area of the clear glass and the area of the colored glass. The entire window is 3 ft by 4 ft and has an area of 12 ft^2 . There are 6 smaller rectangles. Each of these rectangles has a total of 2 full circles of clear glass, because $\frac{4}{2} = 2$ and $\frac{2}{2} + \frac{4}{4} = 2$. In the entire window, there are 12 complete circles of clear glass. Each circle has diameter 1 ft, radius $\frac{1}{2}$ ft, and area $\frac{1}{4}\pi \text{ ft}^2$. The area of the clear glass is $12 \cdot \frac{1}{4}\pi$, or approximately 9.42 ft^2 . That means the area of colored glass is approximately $12 - 9.42$, or 2.58 ft^2 .

Next, we need to find the total length of the seams between the pieces of glass and the frame around the window. The 12 circles each have a circumference of 1π ft, which makes 12π ft or about 37.68 ft of curved seams. There are also 11 ft of straight seams, because $4 + 4 + 3 = 11$. All together there are about 48.68 ft of seams. Finally, there is 14 ft of frame all the way around the window.

Next, we can calculate how much each material will cost. The clear glass will cost $9.42 \cdot 2$, or \$18.84. The colored glass will cost $2.58 \cdot 5$, or \$12.90. The seams will cost $48.68 \cdot 0.10$, or \$4.87. The frame will cost $14 \cdot 4$, or \$56. The total cost of all the materials is about \$93, because $18.84 + 12.90 + 4.87 + 56.00 = 92.61$. If these assumptions are accurate, they have just enough money to buy the materials, but if they need to pay for the scraps they cut off or if accidentally they break pieces as they go, they don't have a lot of extra money.

Activity Synthesis

As groups complete the activity, combine groups of 2 to make groups of 4. If possible, combine groups who solved the problem in different ways. Display the following questions for all to see and tell the group of 4 to discuss:

- Did you get the same answer? Why or why not?
- Did you use the same strategy? What was the same or different in your work?
- Did you make any assumptions as you worked on the problem?

Ask groups to share the similarities and differences they found in their work. Use MLR 8 (Discussion Supports) to revoice comparison statements and assumptions; ask for details and examples. After each group shares, ask the students if they had any of the same conversations in their own group so as to not have repetitive explanations. Every group does not need to share if the same conversation was had.

Ask students to make explicit any assumptions they made in their work. If it does not come up, bring out the assumption that the shapes are parts of circles and that the total cost only takes into account the exact area and lengths shown in the figure.

11.2 A Bigger Window

Optional: 10 minutes

This is a continuation of the previous one. Students use their cost computations from the previous activity to find the cost of an enlarged version of the stained-glass window, which is now scaled by a factor of 3. Students recognize that the lengths of the frame and seams will increase by a factor of 3, while the area of the glass will increase by a factor of 3^2 .

If students observe that the material for the seams and the frame has width and the scale factor would need to be applied to this measurement, ask them if they can make a simplifying assumption. The width of the seams is never specified or taken into account in the calculations in the previous activity so it is appropriate to continue to put this to the side, as part of the modelling process.

As students work, monitor and select students who solved the problem in different ways to share during the whole-group discussion. If there is a student who quickly assumed they could just multiply their cost from the previous activity by 3, but then realized why they could not do that, select them to share their reasoning.

Addressing

- 7.G.A.1
- 7.G.B.4

Instructional Routines

- MLR3: Clarify, Critique, Correct
- MLR8: Discussion Supports

Launch

As students work in pairs, use MLR 3 (Clarify, Critique, Correct) with the "Critique a Partial or Flawed Response" strategy. Present students with a flawed solution method by a fictitious student. For example, "I learned that when you scale something by a factor, then you multiply things by that factor. If the people want a window three times as big, I multiply what the small window costs by three and get \$279. So \$450 dollars is more than enough."

After giving students some quiet think time, ask, "Why isn't \$450 enough, even though \$450 is more than three times the cost of the original window?" Have students work together to come up with a suggestion to fix the flawed response and possible rules for scaling areas.

Support for Students with Disabilities

Engagement: Develop Effort and Persistence. Encourage and support opportunities for peer interactions. Invite students to talk about their ideas with a partner before writing them down. Display sentence frames to support students when they discuss and explain strategies to solve the problem. For example: “Let’s try....”, “We are trying to....”, “We already know....”, and “We will need to know....”

Supports accessibility for: Language; Social-emotional skills

Anticipated Misconceptions

Some students might think they can multiply the original cost by 3. Encourage them to compute the lengths and areas of the new window, or remind them that while the side lengths in scaled copies increase by the scale factor, the area increases by the square of the scale factor.

Student Task Statement

A local community member sees the school’s stained-glass window and really likes the design. They ask the students to create a larger copy of the window using a scale factor of 3. Would \$450 be enough to buy the materials for the larger window? Explain or show your reasoning.

Student Response

No, \$450 is not enough money. They would need about \$468.27. The lengths of the seams and the frame are one-dimensional, so they scale by 3. The areas of the clear glass and the colored glass are two-dimensional, so they scale by 9.

$$18.84 \cdot 9 + 12.90 \cdot 9 + 4.87 \cdot 3 + 56.00 \cdot 3 = 468.27$$

Activity Synthesis

Ask selected students to share their reasoning. If there are students who still think \$450 is enough money, ask them to share their reasoning. Discuss why you cannot just multiply the price of the original design by 3 to find the price of the scaled stained-glass window.

Support for English Language Learners

Speaking: MLR8 Discussion Supports. As students share how they calculated the total cost of the larger window, press for details in students' explanations by asking how they know that the areas of the clear glass and the colored glass are scaled by 9. Also, ask students how they know the lengths of the seams and the frame are scaled by 3. Listen for and amplify comments that clarify how the scale factor affects the lengths and areas of shapes. For example, the lengths are scaled by the scale factor; however, the area is scaled by the square of the scale factor because the length and width are both scaled by the same scale factor. If necessary, draw a rectangle with a length of 4 units, width of 3 units, and area of 12 square units. Then draw a scaled rectangle by a scale factor of 3 with a length of 12 units and width of 9 units. The area of the scaled rectangle is 108 square units, which is the area of the original rectangle scaled by 9 or 3^2 . This will support rich and inclusive discussion about how the scale factor affects the lengths and area of shapes.

Design Principle(s): Support sense-making

11.3 Invent Your Own Design

Optional: 15 minutes

The purpose of this activity is for students to create their own stained-glass design for a given amount of money. The activity is purposefully left open to allow students to either tweak the previous design or create something completely new.

As students work, monitor and select students who either tweaked a previous design or created a new, interesting design to share during the whole-group discussion.

Addressing

- 7.G.B.4

Instructional Routines

- Group Presentations
- MLR7: Compare and Connect

Launch

Students in same groups. Remind students to include whole or partial circles in their designs.

Anticipated Misconceptions

Some students may think they need to create a new design and struggle getting started. Point these students to the designs in previous activities and ask how they could modify these designs to meet the cost requirement.

Student Task Statement

Draw a stained-glass window design that could be made for less than \$450. Show your thinking. Organize your work so it can be followed by others.

Student Response

Answers vary

Activity Synthesis

Display students' designs for all to see and ask students to explain how they knew their design met the cost requirement. Allow other students to ask questions of the student who is sharing their design.

Support for English Language Learners

Speaking, Listening: MLR7 Compare and Connect. As students prepare their stained-glass window designs, look for students with different solution methods. As students investigate each other's work, ask students to share what worked well in a particular approach. During this discussion, listen for and amplify any comments about what might make the calculation of the cost more precise. Then encourage students to make connections between the quantities used to calculate the cost of the glass and the circles in the stained-glass window design. During this discussion, listen for and amplify language students use to interpret quantities as the total area of the whole or partial circles in their design. This will foster students' meta-awareness and support constructive conversations as they compare strategies for calculating the cost of a stained-glass window and make connections between quantities and the area of circles.

Design Principle(s): Cultivate conversation; Maximize meta-awareness

CKMath[™]
Core Knowledge **MATHEMATICS**[™]



Family Support
Materials

Family Support Materials

Measuring Circles

Here are the video lesson summaries for Grade 7, Unit 3: Measuring Circles. Each video highlights key concepts and vocabulary that students learn across one or more lessons in the unit. The content of these video lesson summaries is based on the written Lesson Summaries found at the end of lessons in the curriculum. The goal of these videos is to support students in reviewing and checking their understanding of important concepts and vocabulary. Here are some possible ways families can use these videos:

- Keep informed on concepts and vocabulary students are learning about in class.
- Watch with their student and pause at key points to predict what comes next or think up other examples of vocabulary terms (the bolded words).
- Consider following the Connecting to Other Units links to review the math concepts that led up to this unit or to preview where the concepts in this unit lead to in future units.

Grade 7, Unit 3: Measuring Circles	Vimeo	YouTube
Video 1: Measuring Relationships (Lesson 1)	Link	Link
Video 2: Circumference of a Circle (Lessons 2-5)	Link	Link
Video 3: Area of a Circle (Lessons 7-9)	Link	Link
Video 4: Distinguishing Circumference and Area (Lesson 10)	Link	Link

Video 1

Video 'VLS G7U3V1 Measuring Relationships (Lesson 1)' available here:
<https://player.vimeo.com/video/469037534>.

Video 2

Video 'VLS G7U3V2 Circumference of a Circle (Lessons 2–5)' available here:
<https://player.vimeo.com/video/471194480>.

Video 3

Video 'VLS G7U3V3 Area of a Circle (Lessons 7–9)' available here: <https://player.vimeo.com/video/471419816>.

Video 4

Video 'VLS G7U3V4 Distinguishing Circumference and Area (Lesson 10)' available here:
<https://player.vimeo.com/video/469897330>.

Connecting to Other Units

- *Coming soon*

Circumference of a Circle

Family Support Materials 1

This week your student will learn why circles are different from other shapes, such as triangles and squares. Circles are perfectly round because they are made up of all the points that are the same distance away from a center.

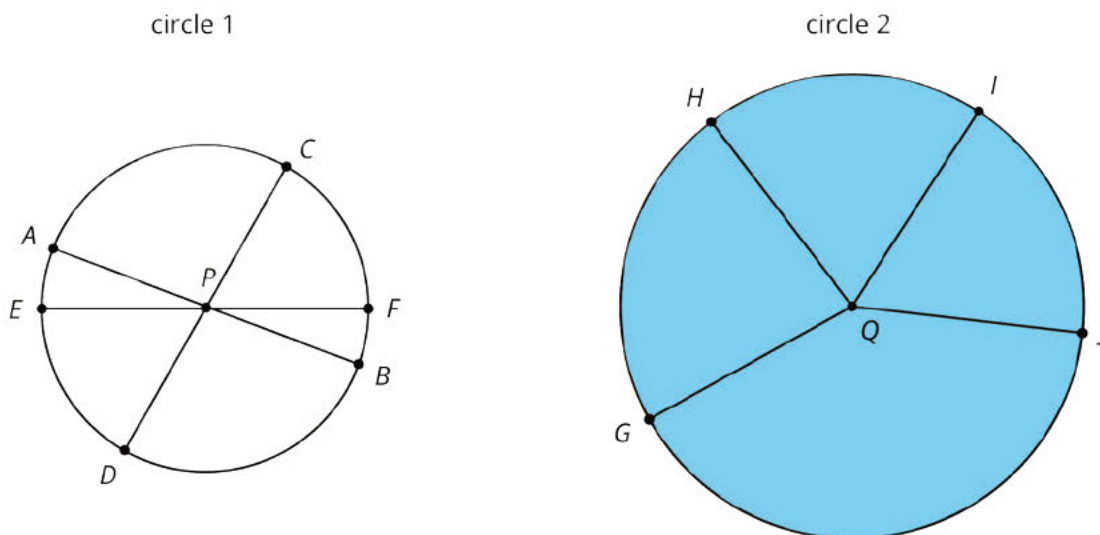

- This line segment from the center to a point on the circle is called the **radius**. For example, the segment from P to F is a radius of circle 1.
- The line segment between two points on the circle and through the center is called the **diameter**. It is twice the length of the radius. For example, the segment from E to F is a diameter of circle 1. Notice how segment EF is twice as long as segment PF.
- The distance around a circle is called the **circumference**. It is a little more than 3 times the length of the diameter. The exact relationship is $C = \pi d$, where π is a constant with infinitely many digits after the decimal point. One common approximation for π is 3.14.

We can use the proportional relationships between radius, diameter, and circumference to solve problems.

Here is a task to try with your student:

A cereal bowl has a diameter of 16 centimeters.

1. What is the *radius* of the cereal bowl?
 - a. 5 centimeters

- b. 8 centimeters
- c. 32 centimeters
- d. 50 centimeters

2. What is the *circumference* of the cereal bowl?

- a. 5 centimeters
- b. 8 centimeters
- c. 32 centimeters
- d. 50 centimeters

Solution:

1. B, 8 centimeters. The diameter of a circle is twice the length of the radius, so the radius is half the length of the diameter. We can divide the diameter by 2 to find the radius. $16 \div 2 = 8$.
2. D, 50 centimeters. The circumference of a circle is π times the diameter.
 $16 \cdot 3.14 \approx 50$.

Area of a Circle

Family Support Materials 2

This week your student will solve problems about the area inside circles. We can cut a circle into wedges and rearrange the pieces without changing the area of the shape. The smaller we cut the wedges, the more the rearranged shape looks like a parallelogram.

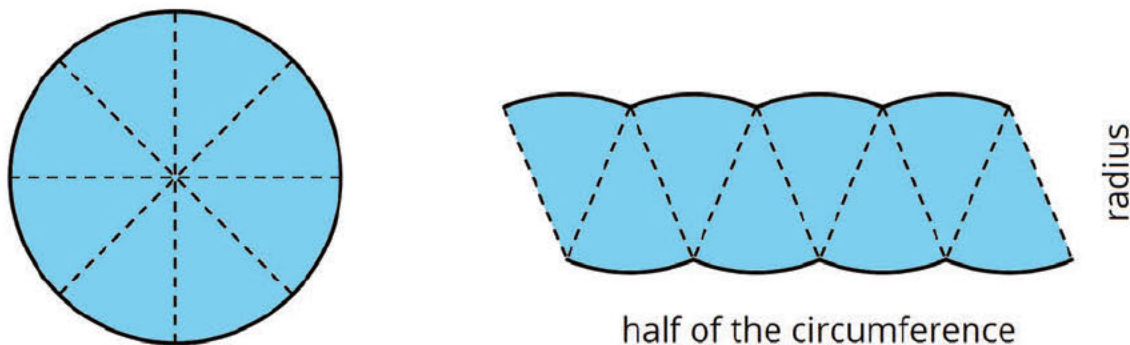

The area of a circle can be found by multiplying half of the circumference times the radius. Using $C = 2\pi r$ we can represent this relationship with the equation:

$$A = \frac{1}{2}(2\pi r) \cdot r$$

Or

$$A = \pi r^2$$

This means that if we know the radius, we can find the area. For example, if a circle has radius 10 cm, then the area is about 314 cm^2 , because $3.14 \cdot 10^2 = 314$. We can also say that the area is $100\pi \text{ cm}^2$.

Here is a task to try with your student:

A rectangular wooden board, 20 inches wide and 40 inches long, has a circular hole cut out of it.

1. The diameter of the circle is 6 inches. What is the area?
2. What is the area of the board after the circle is removed?

Solution:

1. 9π or about 28.26 in^2 . The radius of the hole is half of the diameter, so we can divide $6 \div 2 = 3$. The area of a circle can be calculated $A = \pi r^2$. For a radius of 3, we get $3^2 = 9$. We can write 9π or use 3.14 as an approximation of pi, $3.14 \cdot 9 = 28.26$.

2. $800 - 9\pi$ or about 771.74 in^2 . Before the hole was cut out, the entire board had an area of $20 \cdot 40$ or 800 in^2 . We can subtract the area of the missing part to get the area of the remaining board, $800 - 28.26 = 771.74$.

CKMath™
Core Knowledge **MATHEMATICS™**

Unit Assessments

Check Your Readiness A and B
End-of-Unit Assessment A and B

Measuring Circles: Check Your Readiness (A)

1. A kids' movie ticket costs \$5.25.
 - a. One day, 200 kids' tickets were purchased. What was the total cost of those tickets?

 - b. If t is the number of kids' tickets purchased, and c is the total cost of those tickets, write an equation that relates c to t .

 - c. Another day, the total cost of kids' tickets was \$813.75. How many tickets were purchased that day?

2. The sides of a square have length s .
 - a. Write a formula for the perimeter P of the square.

 - b. Write a formula for the area A of the square.

3. Priya measured the perimeter of a square desk and found 248 cm. Noah measured the perimeter of the same desk and found 2,468 mm.

a. By how many millimeters do these measurements differ?

b. Why do you think Priya and Noah may have found different measurements for the same desk?

4. Each small square in the graph paper represents 1 square unit. Find the area of the given figure in square units. Explain your reasoning.

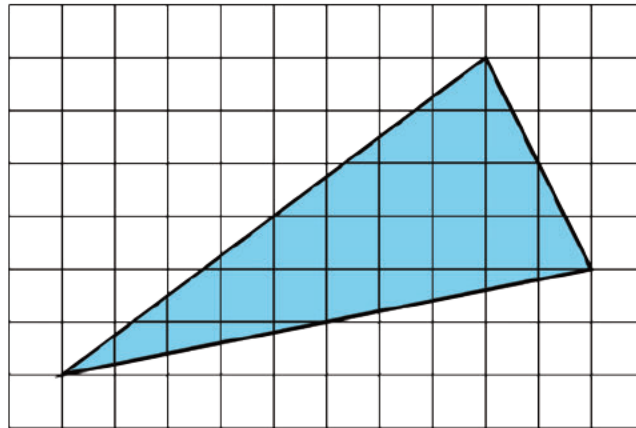

5. A map of Utah is shown. Which area is closest to the area of Utah?

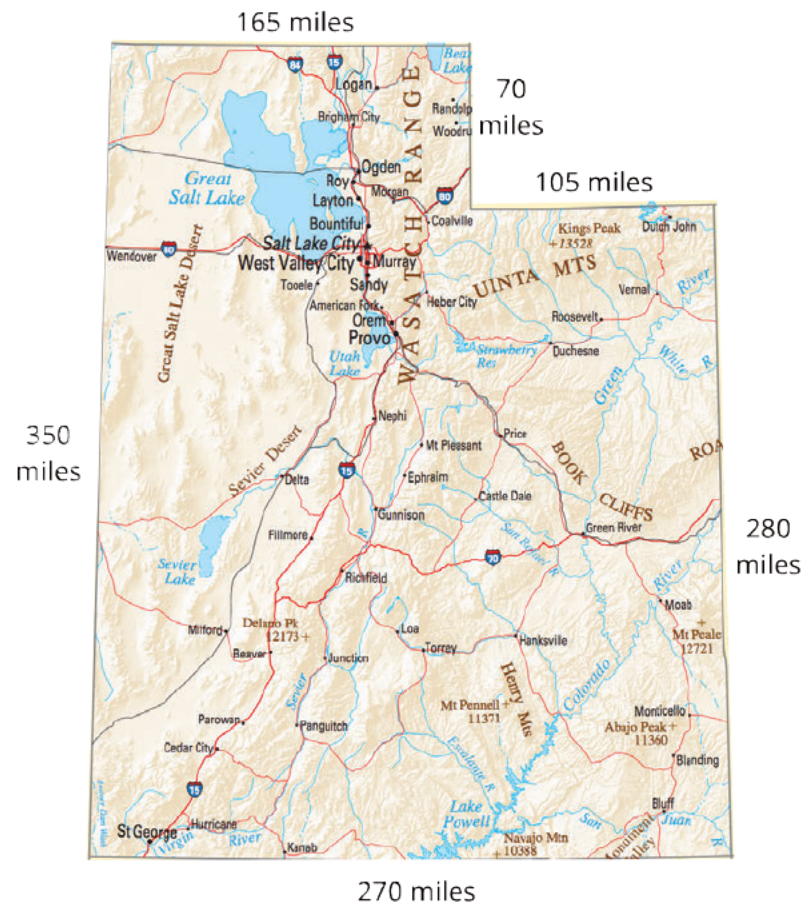

- A. 1,240 square miles
- B. 87,150 square miles
- C. 94,500 square miles
- D. 119,000 square miles

6. Here is a picture of a circle. Each square represents 1 square unit.

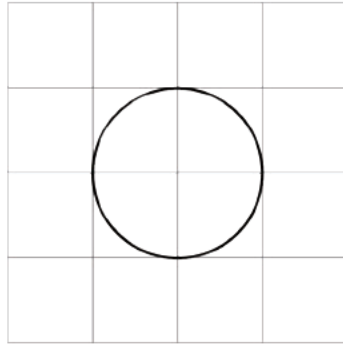

- a. Explain why the area of the circle is less than 4 square units.

- b. Explain why the area of the circle is more than 2 square units.

- c. Do you think the area of the circle is more or less than 3 square units?

Measuring Circles: Check Your Readiness (B)

1. A kid's movie ticket costs \$7.75.
 - a. One day, 300 kids' tickets were purchased. What was the total cost of those tickets?

 - b. If t is the number of kids' tickets purchased, and c is the cost of those tickets, write an equation that relates c to t .

 - c. Another day, the cost of kids' tickets was \$527. How many tickets were purchased that day?

2. Here are the dimensions of some rectangles. Which rectangle has an area of 12 square units and a perimeter of 14 units?
 - A. a length of 1 unit and a width of 12 units
 - B. a length of 6 units and a width of 1 unit
 - C. a length of 6 units and a width of 2 units
 - D. a length of 3 units and a width of 4 units

3. Elena measured the perimeter of a square desk and found 359 cm. Andre measured the perimeter of the same desk and found 3,579 mm.

a. By how many millimeters do these measurements differ?

b. Why do you think Elena and Andre may have found different measurements for the same desk?

4. Each small square in the grid represents 1 square unit. Find the area of the figure in square units. Explain your reasoning.

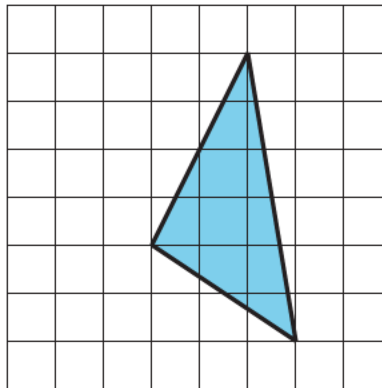

5. A map of Utah is shown. Which area is closest to the area of Utah in square kilometers?



- A. 274,963
- B. 244,905
- C. 225,808
- D. 1,997

6. This star was made by putting together arcs from four circles. Each small grid square represents one square unit.

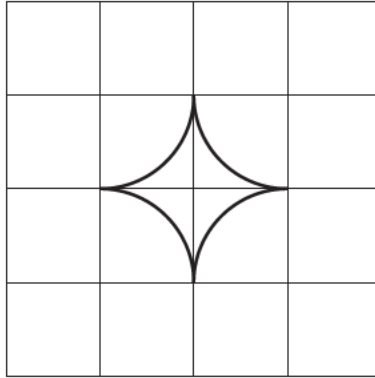

- a. Explain why the area of the star is less than 4 square units.
- b. Explain why the area of the star is less than 2 square units.
- c. Do you think the area of the star is more or less than 1 square unit?

Measuring Circles: End-of-Unit Assessment (A)

1. A circle has radius 50 cm. Which of these is *closest* to its area?
 - A. 157 cm^2
 - B. 314 cm^2
 - C. $7,854 \text{ cm}^2$
 - D. $15,708 \text{ cm}^2$
2. The shape is composed of three squares and two semicircles. Select **all** the expressions that correctly calculate the perimeter of the shape.

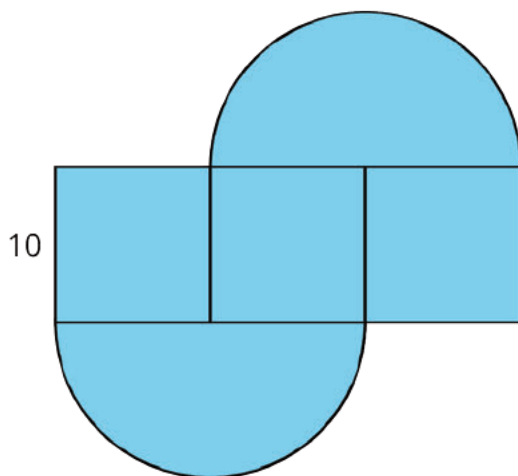

- A. $40 + 20\pi$
- B. $80 + 20\pi$
- C. $120 + 20\pi$
- D. $300 + 100\pi$
- E. $10 + 10 + 10\pi + 10 + 10 + 10\pi$

3. Select all of the true statements.

- A. π is the area of a circle of radius 1.
- B. π is the area of a circle of diameter 1.
- C. π is the circumference of a circle of radius 1.
- D. π is the circumference of a circle of diameter 1.
- E. π is the constant of proportionality relating the diameter of a circle to its circumference.
- F. π is the constant of proportionality relating the radius of a circle to its area.

4. A class measured the radius and circumference of various circular objects. The results are plotted on the graph.

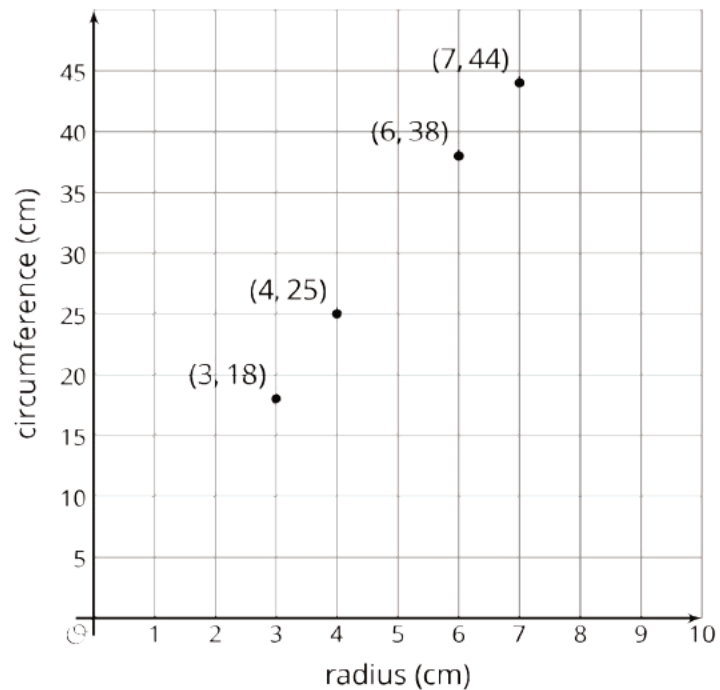

- a. Does there appear to be a proportional relationship between the radius and circumference of a circle? Explain or show your reasoning.

- b. Why might the measured radii and circumferences not be *exactly* proportional?

5. For each quantity, decide whether circumference or area would be needed to calculate it. Explain or show your reasoning.

- a. The distance around a circular track.
- b. The total number of equally-sized tiles on a circular floor.
- c. The amount of oil it takes to cover the bottom of a frying pan.
- d. The distance your car will go with one turn of the wheels.

6. This figure is made from a part of a square and a part of a circle.

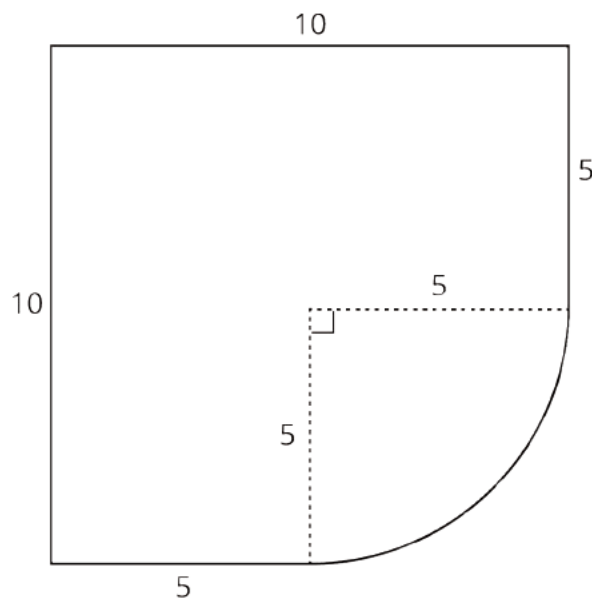

a. What is the perimeter of this figure, to the nearest unit?

b. What is the area of this figure, to the nearest square unit?

7. A groundskeeper needs grass seed to cover a circular field, 290 feet in diameter.

A store sells 50-pound bags of grass seed. One pound of grass seed covers about 400 square feet of field.

What is the smallest number of bags the groundskeeper must buy to cover the circular field? Explain or show your reasoning.

Measuring Circles: End-of-Unit Assessment (B)

1. A circle has radius 40 cm. Which of these is *closest* to its area?

A. $10,053 \text{ cm}^2$

B. $5,026 \text{ cm}^2$

C. 251 cm^2

D. 126 cm^2

2. The shape is composed of squares and quarter circles. Select all the expressions that represent its perimeter.

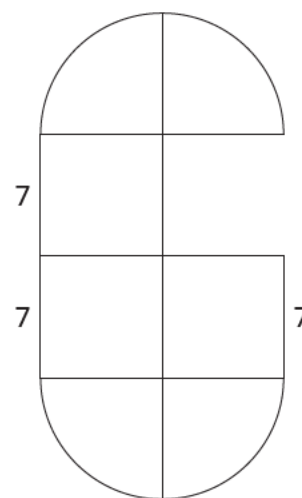

A. $42 + 14\pi$

B. $7 + 7 + 7 + 7 + 7 + 7 + 3.5\pi + 3.5\pi + 3.5\pi + 3.5\pi$

C. $91 + 14\pi$

D. $147 + 49\pi$

E. $7 + 7 + 7 + 7 + 7 + 7 + 7 + 7 + 7 + 7$

3. Select all true statements.

Circle A

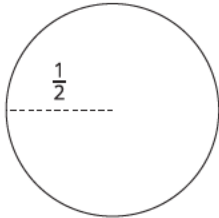

Circle B

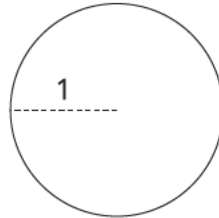

Circle C

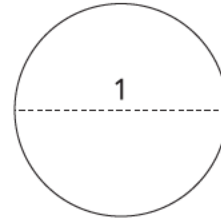

- A. Circle A has a circumference of π .
- B. Circle B has a circumference of π .
- C. Circle B has an area of π .
- D. Circle C has an area of π .
- E. π is the constant of proportionality relating the radius of a circle to its circumference.
- F. π is the constant of proportionality relating the diameter of a circle to its circumference.

4. For each quantity, decide whether circumference or area would be needed to calculate it. Explain or show your reasoning.

- a. The distance around a Ferris wheel.
- b. The amount of paint needed to paint a bullseye.
- c. The amount of whipped cream needed to go around the edge of a pie.
- d. The amount of material needed to make a drum head (the part of the drum you hit).

5. A class measured the radius r , circumference C , and area A of various circular objects. The results are recorded in this table.

r (cm)	C (cm)	A (cm ²)
4	25	50
5	31.5	78.5
8	50	201
12	75	452

- a. Does there appear to be a proportional relationship between circumference and area? Explain or show your reasoning.
- b. Does the equation $A = \frac{1}{2} \cdot r \cdot C$ describe the relationships in the table? Explain your reasoning.

6. This figure is made from part of a circle and part of a square.

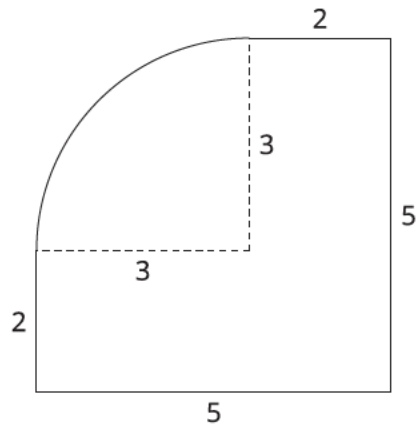

a. What is the perimeter of this figure, to the nearest unit?

b. What is the area of this figure, to the nearest square unit?

7. A painter needs to paint the bottom of a circular pool. The pool has a radius of 30 feet.

A store sells 5-gallon cans of paint. One gallon of paint covers 300 square feet.

What is the smallest number of 5-gallon cans the painter must buy to cover the bottom of the pool? Explain or show your reasoning.

CKMath™
Core Knowledge **MATHEMATICS™**

Assessment Answer Keys

Check Your Readiness A and B
End-of-Unit Assessment A and B

Assessments

Assessment : Check Your Readiness (A)

Problem 1

The content assessed in this problem is first encountered in Lesson 4: Applying Circumference.

Students find a linear equation to represent a ratio. Students may or may not use the equation in order to answer the question in part c. A ratio table would also be effective, but because the numbers are large, the equation may be more efficient. Since the unit rate is given, students might also answer part c by doing the relevant arithmetic without referring to the equation.

If most students do well with this item, plan to emphasize, in Lesson 3, the value of knowing that the circumference and diameter of a circle have a proportional relationship. Ask students, "If I know that the circumference is always about three times the diameter, what else can I figure out? What if the diameter is 10 units? 100 units? 1 unit? How do you know?" "What if I know the circumference is 60 units?" Make sure students understand the relationship between the patterns they noticed and the equation $C = (\pi)d$. The warm-up in Lesson 4 gives another opportunity to assess students' understanding of the value of knowing the relationship. Optional Lesson 5 gives students more opportunities to practice using the proportional relationship.

Statement

A kids' movie ticket costs \$5.25.

1. One day, 200 kids' tickets were purchased. What was the total cost of those tickets?
2. If t is the number of kids' tickets purchased, and c is the total cost of those tickets, write an equation that relates c to t .
3. Another day, the total cost of kids' tickets was \$813.75. How many tickets were purchased that day?

Solution

1. \$1050
2. $c = 5.25t$ (or equivalent)
3. 155 tickets ($813.75 \div 5.25 = 155$)

Aligned Standards

6.EE.C.9, 6.RP.A.3

Problem 2

The content assessed in this problem is first encountered in Lesson 1: How Well Can You Measure?.

The formula for the circumference and area of a circle build naturally on simpler formulas for perimeters and areas of polygons. This item recalls what students have done with perimeter and area of a square.

If most students struggle with this item, plan to incorporate these expressions into Activities 2 and 3 to connect how students used the squares' side lengths to find the perimeters and areas.

Statement

The sides of a square have length s .

1. Write a formula for the perimeter P of the square.
2. Write a formula for the area A of the square.

Solution

1. $P = 4s$ (or equivalent)
2. $A = s^2$ (or equivalent)

Aligned Standards

6.EE.A.2

Problem 3

The content assessed in this problem is first encountered in Lesson 1: How Well Can You Measure?.

In this unit, students will measure circles in order to discover a relationship between the circumference and the diameter. As a result, they will need to deal with measurement error. This problem asks students to explain a discrepancy in measurement.

If most students struggle with this item, plan to incorporate reporting the measures in Activity 2 as millimeters as well as to the nearest centimeter. Ask how using different levels of precision changes how we report measurements. This will be important as students measure parts of a circle. A lack of precision may hide the relationships that students need to notice and use, and not understanding that some error is inherent in human measuring may mean that students discount the overall patterns.

Statement

Priya measured the perimeter of a square desk and found 248 cm. Noah measured the perimeter of the same desk and found 2,468 mm.

1. By how many millimeters do these measurements differ?

2. Why do you think Priya and Noah may have found different measurements for the same desk?

Solution

- 12 because 248 cm is 2,480 mm and $2480 - 2468 = 12$.
- Answers vary. Sample response 1: Priya may have rounded her measurements of each side of the square to the nearest cm while Noah may have rounded to the nearest mm. Sample response 2: the measurements are not exact and so there may have been some error in Priya's measurement, Noah's measurement, or both.

Aligned Standards

4.MD.A.1, 4.MD.A.3

Problem 4

The content assessed in this problem is first encountered in Lesson 6: Estimating Areas.

In the second section of this unit, students decompose, rearrange, and enclose shapes while exploring different methods to find the area of a circle. If most students struggle with this item, plan to use it as the Warm-up for Lesson 6. Students learned a variety of strategies for finding areas in Unit 1 of Grade 6, and revisiting the strategies may be enough support. Be sure to call on students who used different strategies.

Statement

Each small square in the graph paper represents 1 square unit. Find the area of the given figure in square units. Explain your reasoning.

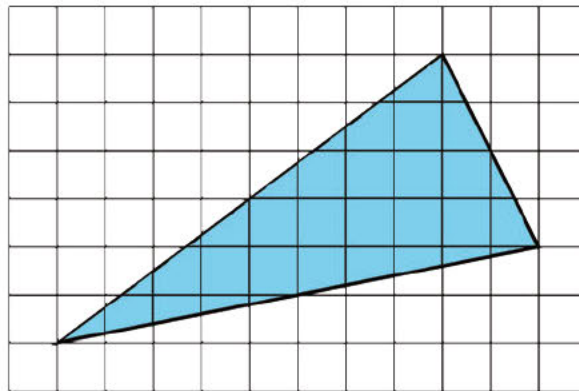

Solution

22 square units. Possible strategy: Draw a 10×6 box that just encloses the triangle, area 60 square units. The three triangles that are inside the rectangle but outside the blue triangle are each right triangles with area 24, 4, and 10. $60 - (24 + 4 + 10) = 22$.

Aligned Standards

6.G.A.1

Problem 5

The content assessed in this problem is first encountered in Lesson 6: Estimating Areas.

Students selecting A have calculated the perimeter instead of the area. Students selecting C calculated the area of the larger rectangle containing the state ($350 \cdot 270$). Students selecting D may have treated the sides of length 165, 70, and 105 miles as one long horizontal side, and multiplied their sum by 350.

If most students struggle with this item, plan to use it as part of the Warm-up for Lesson 6 as well. Ask about this item before asking about Item 4. In the other activities in the lesson, students practice decomposing figures to find areas. If students need more support, consider using activities from Unit 1 in Grade 6.

Statement

A map of Utah is shown. Which area is closest to the area of Utah?

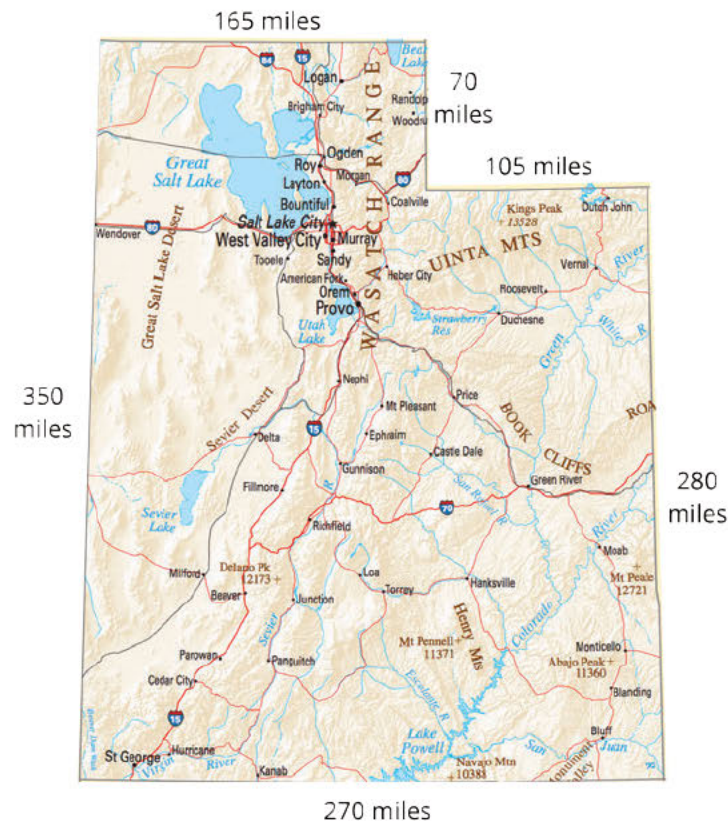

- A. 1,240 square miles
- B. 87,150 square miles
- C. 94,500 square miles
- D. 119,000 square miles

Solution

B

Aligned Standards

6.EE.B.7

Problem 6

The content assessed in this problem is first encountered in Lesson 7: Exploring the Area of a Circle.

Students estimate the area of an irregular shape by comparing with shapes composed of rectangles and triangles. Some students may have already encountered the formula for the area of a circle before and may use that as a response in part c. If not, students might cut up unit squares to see how many fit in the circle—but it will still be close! Encourage students who want to spend a long time on part c to do the rest of the assessment first, then come back to it. The idea of this problem is to get a sense of what strategies students use to compare areas.

If most students struggle with this item, it's not necessary to take action, but note their strategies as you prepare to teach lesson 7.

Statement

Here is a picture of a circle. Each square represents 1 square unit.

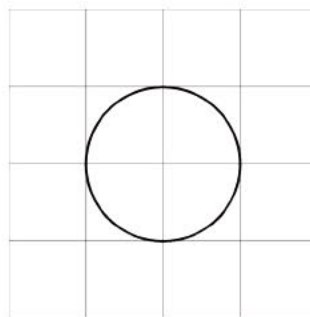

1. Explain why the area of the circle is less than 4 square units.
2. Explain why the area of the circle is more than 2 square units.
3. Do you think the area of the circle is more or less than 3 square units?

Solution

1. The circle fits inside a 2-by-2 square, so its area is less than 4 square units.

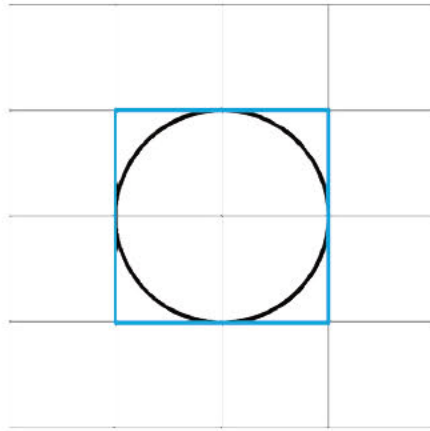

2. Answers vary. Sample response: Decompose two square units into 4 triangles that fit inside the circle.

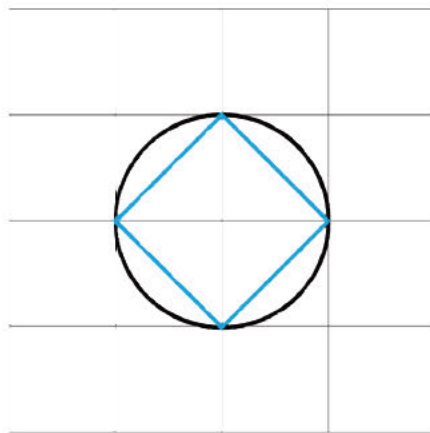

3. Answers vary. Sample response: It is difficult to tell from the picture. It looks like the area of the circle is close to 3 square units.

Aligned Standards

6.G.A.1

Assessment : Check Your Readiness (B)

Problem 1

The content assessed in this problem is first encountered in Lesson 4: Applying Circumference.

Students find an equation to represent a proportional relationship. Students may or may not use the equation in order to answer the question in part c. A table would also be effective, but because the numbers are large, the equation may be more efficient. Since the unit rate is given, students might also answer part c by doing the relevant arithmetic without referring to the equation.

If most students do well with this item, plan to emphasize, in Lesson 3, the value of knowing that the circumference and diameter of a circle have a proportional relationship. Ask students, "If I know that the circumference is always about three times the diameter, what else can I figure out? What if the diameter is 10 units? 100 units? 1 unit? How do you know?" "What if I know the circumference is 60 units?" Make sure students understand the relationship between the patterns they noticed and the equation $C = (\pi)d$. The warm-up in Lesson 4 gives another opportunity to assess students' understanding of the value of knowing the relationship. Optional Lesson 5 gives students more opportunities to practice using the proportional relationship.

Statement

A kid's movie ticket costs \$7.75.

1. One day, 300 kids' tickets were purchased. What was the total cost of those tickets?
2. If t is the number of kids' tickets purchased, and c is the cost of those tickets, write an equation that relates c to t .
3. Another day, the cost of kids' tickets was \$527. How many tickets were purchased that day?

Solution

1. \$2,325
2. $c = 7.75t$ (or equivalent)
3. 68 tickets ($527 \div 7.75 = 68$)

Aligned Standards

6.EE.C.9, 6.RP.A.3

Problem 2

The content assessed in this problem is first encountered in Lesson 1: How Well Can You Measure?.

The formula for the circumference and area of a circle build naturally on simpler formulas for perimeters and areas of polygons. This item recalls what students have done with perimeter and area of a square. Students selecting A or C have doubled only one side length of the rectangle to find the perimeter. Students selecting B may have been thinking of perimeter when computing area, using the incorrect formula $A = 2\ell w$.

If most students struggle with this item, plan to incorporate these expressions into Activities 2 and 3 to connect how students used the squares' side lengths to find the perimeters and areas.

Statement

Here are the dimensions of some rectangles. Which rectangle has an area of 12 square units and a perimeter of 14 units?

- A. a length of 1 unit and a width of 12 units
- B. a length of 6 units and a width of 1 unit
- C. a length of 6 units and a width of 2 units
- D. a length of 3 units and a width of 4 units

Solution

D

Aligned Standards

6.EE.A.2

Problem 3

The content assessed in this problem is first encountered in Lesson 1: How Well Can You Measure?.

In this unit, students will measure circles in order to discover a relationship between the circumference and the diameter. As a result, they will need to deal with measurement error. This problem asks students to explain a discrepancy in measurement.

If most students struggle with this item, plan to incorporate reporting the measures in Activity 2 as millimeters as well as to the nearest centimeter. Ask how using different levels of precision changes how we report measurements. This will be important as students measure parts of a circle. A lack of precision may hide the relationships that students need to notice and use, and not understanding that some error is inherent in human measuring may mean that students discount the overall patterns.

Statement

Elena measured the perimeter of a square desk and found 359 cm. Andre measured the perimeter of the same desk and found 3,579 mm.

1. By how many millimeters do these measurements differ?

2. Why do you think Elena and Andre may have found different measurements for the same desk?

Solution

- 11 because 359 cm is 3,590 mm and $3590 - 3579 = 11$.
- Answers vary. Sample responses:
 - Elena may have rounded her measurements of each side of the square to the nearest cm while Andre may have rounded to the nearest mm.
 - The measurements are not exact and so there may have been some error in Elena's measurement, Andre's measurement, or both.

Aligned Standards

4.MD.A.1, 4.MD.A.3

Problem 4

The content assessed in this problem is first encountered in Lesson 6: Estimating Areas.

In the second section of this unit, students decompose, rearrange, and enclose shapes while exploring different methods to find the area of a circle. If most students struggle with this item, plan to use it as the Warm-up for Lesson 6. Students learned a variety of strategies for finding areas in Unit 1 of Grade 6, and revisiting the strategies may be enough support. Be sure to call on students who used different strategies.

Statement

Each small square in the grid represents 1 square unit. Find the area of the figure in square units. Explain your reasoning.

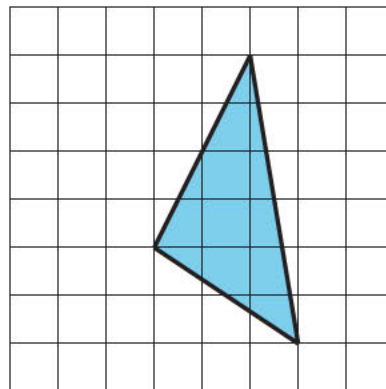

Solution

8 square units. Possible strategy: Draw a 3 by 6 box that just encloses the triangle, area 18 square units. The three triangles that are inside the rectangle but outside the original triangle are each right triangles with areas of 3, 3, and 4. $18 - (3 + 3 + 4) = 8$.

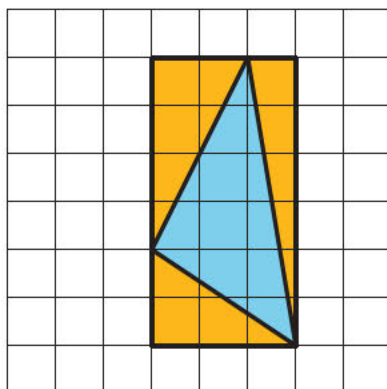

Aligned Standards

6.G.A.1

Problem 5

The content assessed in this problem is first encountered in Lesson 6: Estimating Areas.

Students selecting A found the area of the larger rectangle around the state plus the area of the tip of the decomposed state. Students selecting B calculated the area of the larger rectangle containing the state: $563 \cdot 435$. Students selecting D calculated the perimeter instead of the area.

If most students struggle with this item, plan to use it as part of the Warm-up for Lesson 6 as well. Ask about this item before asking about Item 4. In the other activities in the lesson, students practice decomposing figures to find areas. If students need more support, consider using activities from Unit 1 in Grade 6.

Statement

A map of Utah is shown. Which area is closest to the area of Utah in square kilometers?



- A. 274,963
- B. 244,905
- C. 225,808
- D. 1,997

Solution

C

Aligned Standards

6.EE.B.7

Problem 6

The content assessed in this problem is first encountered in Lesson 7: Exploring the Area of a Circle.

Students estimate the area of an irregular shape by comparing with shapes composed of rectangles and triangles. Some students may have already encountered the formula for the area of a circle before. These students may approach part c by realizing that the negative space in the 2-by-2 box around the star can be rearranged to form a circle. If not, students who are not satisfied by the visual might cut up unit squares to see how many fit in the star. Encourage students who want to spend a long time on part c to do the rest of the assessment first, then come back to it. The idea of this problem is to get a sense of what strategies students use to compare areas.

If most students struggle with this item, it's not necessary to take action, but note their strategies as you prepare to teach lesson 7.

Statement

This star was made by putting together arcs from four circles. Each small grid square represents one square unit.

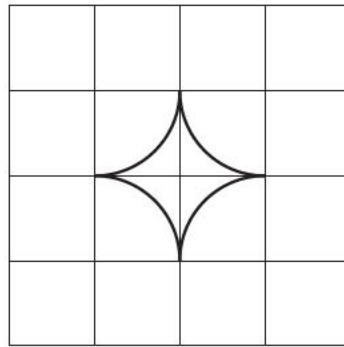

1. Explain why the area of the star is less than 4 square units.
2. Explain why the area of the star is less than 2 square units.
3. Do you think the area of the star is more or less than 1 square unit?

Solution

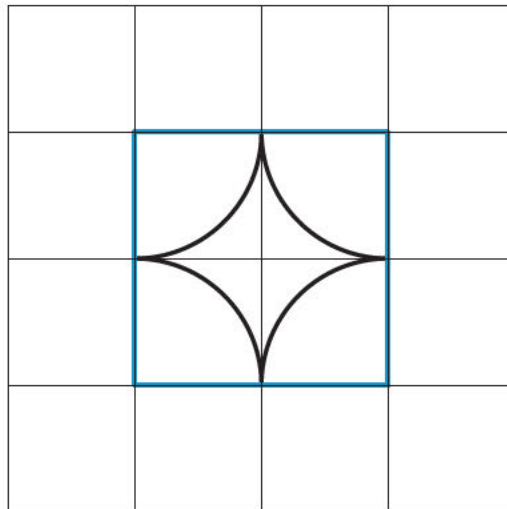

1. The star fits in a 2 by 2 square, so its area is less than 4 square units.

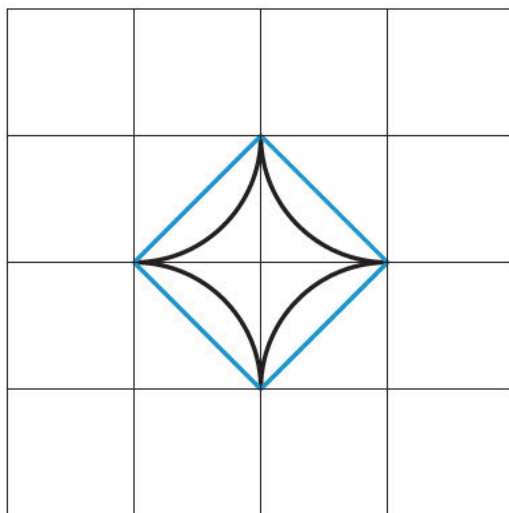

2. Answers vary. Sample response: Decompose two square units into four triangles that surround the star.
3. Answers vary. Sample response: It looks like each quadrant of the star takes up less than half of the area of the triangle from part b that surrounds it, so the star has area less than 1 square unit.

Aligned Standards

6.G.A.1

Assessment : End-of-Unit Assessment (A)

Teacher Instructions

Consider allowing access to a calculator.

Problem 1

This question is meant to be a straightforward check that students can calculate the area of a circle. Because different classes may use different approximations for π , students are not expected to find answers that precisely match the correct choice (C).

Students selecting A have calculated πr but have not squared the radius. Students selecting B have calculated the circumference, $2\pi r$. Students selecting C have calculated the area, πr^2 . Students selecting D have combined the formulas for circumference and area, calculating $2\pi r^2$.

Statement

A circle has radius 50 cm. Which of these is *closest* to its area?

- A. 157 cm²
- B. 314 cm²
- C. 7,854 cm²
- D. 15,708 cm²

Solution

C

Aligned Standards

7.G.B.4

Problem 2

In addition to having students work with perimeter and circumference, this problem assesses students' skill in partitioning a diagram into useful sections, another important strand in this unit.

Students failing to select A may not recognize this answer choice as a simplified version of their own work. Students selecting B have found the perimeter of the rectangle and added it to the circumference of the circle. Students selecting C have found the perimeter of the circle and the three squares. Students selecting D have calculated the area of the shape rather than the perimeter. Students failing to select E may have calculated the perimeter in a different way (say, by realizing they could treat the two semicircles as one full circle) not recognizing this approach, or they may simply have figured that A is the only correct answer.

Statement

The shape is composed of three squares and two semicircles. Select **all** the expressions that correctly calculate the perimeter of the shape.

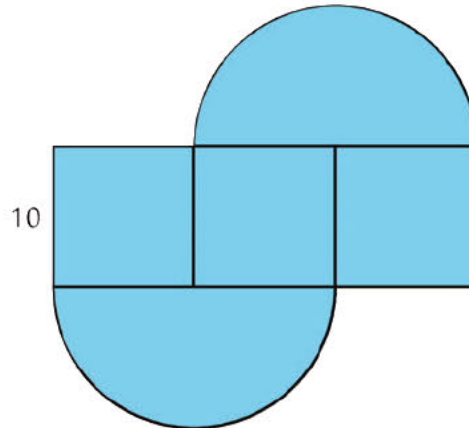

- A. $40 + 20\pi$
- B. $80 + 20\pi$
- C. $120 + 20\pi$
- D. $300 + 100\pi$
- E. $10 + 10 + 10\pi + 10 + 10 + 10\pi$

Solution

["A", "E"]

Aligned Standards

7.G.B.4

Problem 3

In this unit, π is defined as the constant of proportionality relating the diameter to the circumference of a circle. But π also appears in the formula for the *area* of a circle. This problem verifies students' understanding of the dual roles played by π in the study of circles. A student who cannot answer this question but can answer the previous two questions may be over-reliant on formula work.

Students selecting B instead of A, or selecting both A and B, need a review of how the area of a circle is determined. Students selecting C instead of D, or selecting both C and D, need a review of how the circumference of a circle is determined. Students failing to select E may need some additional practice with proportional relationships. Students selecting F may be confusing area with circumference or may need additional practice with proportional relationships.

Statement

Select **all** of the true statements.

- A. π is the area of a circle of radius 1.
- B. π is the area of a circle of diameter 1.
- C. π is the circumference of a circle of radius 1.
- D. π is the circumference of a circle of diameter 1.
- E. π is the constant of proportionality relating the diameter of a circle to its circumference.
- F. π is the constant of proportionality relating the radius of a circle to its area.

Solution

["A", "D", "E"]

Aligned Standards

7.G.B.4, 7.RP.A.2.b

Problem 4

This problem mimics the activity students did in Lesson 3, when they discovered that circumference and diameter are related by a constant of proportionality called π . There are a variety of approaches students can take to argue that the circumference and radius are proportional: for example, draw a line through the plotted points to show that the line comes very close to passing through each point and through $(0, 0)$, or divide each of the circumferences by its corresponding radius. Students who take the latter approach will find constants of proportionality in the 6 to 6.4 range, since the true constant of proportionality is 2π .

The second part of the question gets at another issue that came up during that activity: measurement error. In fact, the measured points are not in a true proportional relationship, though they are close enough that they are good evidence for the proportionality of radius and circumference.

Statement

A class measured the radius and circumference of various circular objects. The results are plotted on the graph.

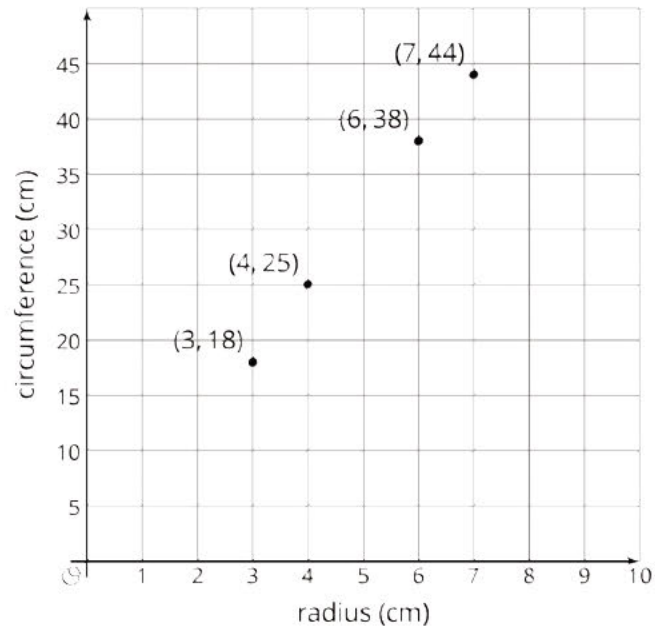

1. Does there appear to be a proportional relationship between the radius and circumference of a circle? Explain or show your reasoning.
2. Why might the measured radii and circumferences not be *exactly* proportional?

Solution

1. Yes. Explanations vary. Sample explanation: If you divide each circumference by its radius, you get the numbers 6, 6.25, approximately 6.33, and approximately 6.29. These numbers are close enough that they are evidence of a proportional relationship between circumference and radius.
2. The measurements were taken using rulers that only have so much accuracy. Students needed to round their answers to the nearest ruler marking, or perhaps rounded even less accurately than that. Also, students probably didn't hold the rulers perfectly still or perfectly straight.

Minimal Tier 1 response:

- Work is complete and correct.
- Acceptable errors: in part a, writing or implying that the points are collinear.
- Sample:
 1. (With accompanying line drawn in) Yes, because the points are on a line that goes through (0,0).
 2. The points are not exact because of error in measurement.

Tier 2 response:

- Work shows general conceptual understanding and mastery, with some errors.
- Sample errors: division errors make it look as if the ratios are not similar enough to indicate a constant of proportionality, explanation in part b does not appeal to measurement error in some way.

Tier 3 response:

- Significant errors in work demonstrate lack of conceptual understanding or mastery.
- Sample errors: errors types from Tier 2 response on both problem parts, explanation in part a does not appeal to facts students know about proportional relationships.

Aligned Standards

7.G.B.4

Problem 5

This problem has students distinguish area from circumference in various real-world contexts. It will likely be difficult for students to say precisely why each problem is about area or circumference. Look for responses that appeal to the exterior of a shape vs. the interior and to the fact that surfaces have to do with area.

Statement

For each quantity, decide whether circumference or area would be needed to calculate it. Explain or show your reasoning.

1. The distance around a circular track.
2. The total number of equally-sized tiles on a circular floor.
3. The amount of oil it takes to cover the bottom of a frying pan.
4. The distance your car will go with one turn of the wheels.

Solution

1. Circumference. The distance around the track is the circumference of the circular track.
2. Area. The number of tiles it takes to cover the floor times the area of each tile is the area of the floor.
3. Area. The pan is circular and the entire circular surface is being covered in oil. To know how much oil is used, we need to know the area of the circle (as well as the thickness of the layer of oil).
4. Circumference. The distance the car goes in one rotation is the distance around (circumference of) the tires.

Minimal Tier 1 response:

- Work is complete and correct.
- Acceptable errors: an illuminating drawing can take the place of a verbal explanation.
- Sample:
 1. Circumference, because around the track means around the circle.
 2. Area, because covering a surface is about area.
 3. Area, because you cover the inside of the pan with oil, not just the rim.
 4. Circumference, because when a tire rolls it's only the outside that counts.

Tier 2 response:

- Work shows general conceptual understanding and mastery, with some errors.
- Sample errors: correct answers with no explanation or misguided explanation, one incorrect answer.

Tier 3 response:

- Significant errors in work demonstrate lack of conceptual understanding or mastery.
- Sample errors: two or more incorrect answers, two or more answers with very poor explanation.

Aligned Standards

7.G.B.4

Problem 6

Watch for students accidentally using the inner 5-unit lengths as part of the perimeter of the figure. Some students may have trouble recognizing the bottom right as a quarter-circle. Direct these students to the phrasing “part of . . . a circle” in the problem.

Statement

This figure is made from a part of a square and a part of a circle.

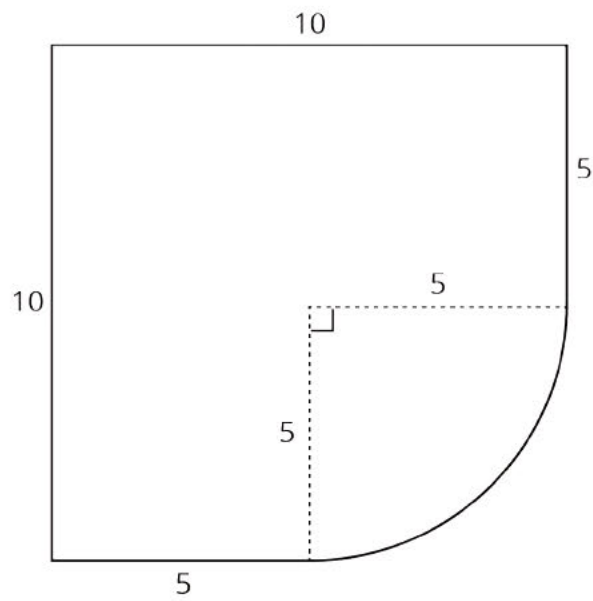

1. What is the perimeter of this figure, to the nearest unit?
2. What is the area of this figure, to the nearest square unit?

Solution

1. 38 units (The quarter-circle's perimeter is $\frac{1}{4} \cdot 2 \cdot \pi \cdot 5$ units. The rest of the perimeter is 30 units. The total perimeter is approximately 37.9 units.)
2. 95 square units (The quarter-circle's area is $\frac{1}{4} \cdot \pi \cdot 5^2$ square units. The rest of the area is 75 square units. The total area is approximately 94.6 square units.)

Aligned Standards

7.G.B.4

Problem 7

In this problem, students must identify the proportional relationship between pounds of grass seed and square feet of grass. Then the formula for the area of a circle is needed to calculate how many bags of seed cover the field. Finally, the student must interpret the result in context to determine the correct number of bags.

The same answer will come from any approximation students use for π .

Statement

A groundskeeper needs grass seed to cover a circular field, 290 feet in diameter.

A store sells 50-pound bags of grass seed. One pound of grass seed covers about 400 square feet of field.

What is the smallest number of bags the groundskeeper must buy to cover the circular field? Explain or show your reasoning.

Solution

4 bags. The field's size is $\pi \cdot 145^2$ square feet, just over 66,000 square feet. Each pound of seed covers 400 square feet; each 50-pound bag covers 20,000 square feet. The number of bags needed is given by:

$$\frac{\pi \cdot 145^2}{20,000} \approx 3.30$$

It is not possible to purchase 3.3 bags, and 3 bags is not enough. It takes 4 bags of grass seed to cover the field.

Minimal Tier 1 response:

- Work is complete and correct, with complete explanation or justification.
- Sample: The area of the field is $\pi \cdot 145^2$ square feet, and each bag covers 20,000 square feet. 3 bags covers 60,000 square feet and that's not enough. 4 bags covers 80,000 square feet and that is enough.

Tier 2 response:

- Work shows good conceptual understanding and mastery, with either minor errors or correct work with insufficient explanation or justification.
- Sample errors: correct calculation (about 3.3 bags) but incorrect use of context gives answers of 3 or 3.3 bags; incorrect calculation of the number of square feet per bag but otherwise correct work, including correct use of contextual rounding; calculation errors, but not errors in formula application, when determining the size of the field or the number of bags; incorrect calculations in determining the number of bags when using a strategy that does not involve dividing.

Tier 3 response:

- Work shows a developing but incomplete conceptual understanding, with significant errors.
- Sample errors: incorrectly determining the area of the field using circumference, or using 145 as the radius; incorrect type of calculation performed on the bags, such as dividing in reverse order; two or more error types from Tier 2 response.
- Acceptable errors: any response giving the correct area of the field earns at least a Tier 3 response, regardless of other work. Any response giving an incorrect area of the field, but correct work on the proportional relationship base on that incorrect area, earns at least a Tier 3 response.

Tier 4 response:

- Work includes major errors or omissions that demonstrate a lack of conceptual understanding and mastery.

- Sample errors: incorrectly determining the area of the field, along with incorrect work on the proportional or contextual relationship; answer without explanation, regardless of accuracy.

Aligned Standards

7.G.B.4, 7.RP.A.2, 7.RP.A.3

Assessment : End-of-Unit Assessment (B)

Teacher Instructions

Consider allowing access to a calculator.

Problem 1

This question is meant to be a straightforward check that students can calculate the area of a circle. Because different classes may use different approximations for π , students are not expected to find answers that precisely match B, the correct choice. Students selecting A have combined the formulas for circumference and area, calculating $2\pi r \cdot 2$ instead of squaring the radius. Students selecting C have calculated the circumference, $2\pi r$. Students selecting D have calculated πr but have not squared the radius.

Statement

A circle has radius 40 cm. Which of these is *closest* to its area?

- A. 10,053 cm²
- B. 5,026 cm²
- C. 251 cm²
- D. 126 cm²

Solution

B

Aligned Standards

7.G.B.4

Problem 2

In addition to having students work with perimeter and circumference, this problem assesses students' skill in partitioning a diagram into useful sections, another important strand in this unit. Students failing to select A may not recognize this answer choice as a simplified version of their own work. Students failing to select A may have calculated the perimeter in a different way (for example, by realizing they could treat the four quarter circles as one full circle) not recognizing this approach, or they may simply have figured that A is the only correct answer. Students selecting C have found the sum of all the lengths shown, including those on the interior of the shape. Students selecting D have calculated the area of the shape. Students selecting E have mistakenly assumed that the arcs of the quarter-circles also have length 7 units.

Statement

The shape is composed of squares and quarter circles. Select **all** the expressions that represent its perimeter.

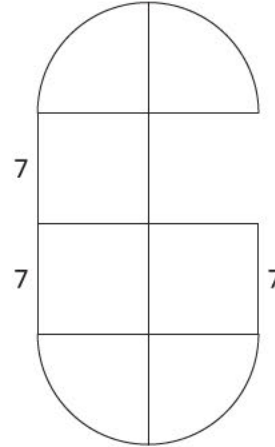

- A. $42 + 14\pi$
- B. $7 + 7 + 7 + 7 + 7 + 7 + 3.5\pi + 3.5\pi + 3.5\pi + 3.5\pi$
- C. $91 + 14\pi$
- D. $147 + 49\pi$
- E. $7 + 7 + 7 + 7 + 7 + 7 + 7 + 7 + 7 + 7 + 7$

Solution

["A", "B"]

Aligned Standards

7.G.B.4

Problem 3

In this unit, π is defined as the constant of proportionality relating the diameter to the circumference of a circle. But π also appears in the formula for the area of a circle. This problem verifies students' understanding of the dual roles played by π in the study of circles. A student who cannot answer this question but can answer the previous two questions may be over-reliant on formula work. Students selecting B instead of A, or selecting both A and B, need a review of how circumference is determined. Students selecting D instead of C, or selecting both C and D, may need a review of how area is determined, or may be confusing area with circumference. Students selecting E instead of F may be thinking of the area formula or may need additional practice with proportional relationships.

Statement

Select **all** true statements.

Circle A

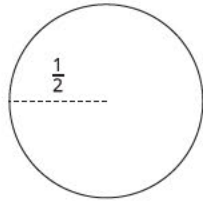

Circle B

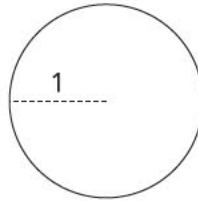

Circle C

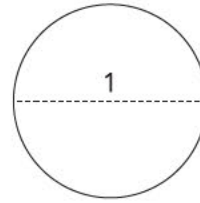

- A. Circle A has a circumference of π .
- B. Circle B has a circumference of π .
- C. Circle B has an area of π .
- D. Circle C has an area of π .
- E. π is the constant of proportionality relating the radius of a circle to its circumference.
- F. π is the constant of proportionality relating the diameter of a circle to its circumference.

Solution

["A", "C", "F"]

Aligned Standards

7.G.B.4, 7.RP.A.2.b

Problem 4

This problem has students distinguish area from circumference in various real-world contexts. It will likely be difficult for students to say precisely why each problem is about area or circumference. Look for responses that appeal to the exterior of a shape vs. the interior and to the fact that surfaces have to do with area.

Statement

For each quantity, decide whether circumference or area would be needed to calculate it. Explain or show your reasoning.

1. The distance around a Ferris wheel.
2. The amount of paint needed to paint a bullseye.
3. The amount of whipped cream needed to go around the edge of a pie.
4. The amount of material needed to make a drum head (the part of the drum you hit).

Solution

1. Circumference. The distance around a Ferris wheel is the circumference of the wheel.

2. Area. The bullseye is a flat surface, so how much paint it takes depends on the area of that surface.
3. Circumference. The whipped cream only goes around the edge of the pie, which is the circumference of the pie.
4. Area. The drum head is a surface.

Minimal Tier 1 response:

- Work is complete and correct.
- Acceptable errors: an illuminating drawing can take the place of a verbal explanation.
- Sample:
 1. Circumference, because the distance around a figure is the definition of the circumference.
 2. Area, because covering a surface is about area.
 3. Circumference, whipped cream goes on the outer edges of the pie.
 4. Area, because it's covering the round surface of the drum.

Tier 2 response:

- Work shows general conceptual understanding and mastery, with some errors.
- Sample errors: correct answers with no explanation or misguided explanation; one incorrect answer.

Tier 3 response:

- Significant errors in work demonstrate lack of conceptual understanding or mastery. Sample errors: two or more incorrect answers; two or more answers with very poor explanation.

Aligned Standards

7.G.B.4

Problem 5

This problem harkens back to an the activity students did in Lesson 3, when they discovered that circumference and diameter are related by a constant of proportionality called π . In this problem, students examine the relationship between circumference and area, which is not proportional. Some students may remember the relationship $\text{Area} = \frac{1}{2}\text{circumference} \cdot \text{radius}$ from Lesson 8, but the expectation is that students will use the values in the tables to verify it.

Statement

A class measured the radius r , circumference C , and area A of various circular objects. The results are recorded in this table.

r (cm)	C (cm)	A (cm ²)
4	25	50
5	31.5	78.5
8	50	201
12	75	452

1. Does there appear to be a proportional relationship between circumference and area? Explain or show your reasoning.
2. Does the equation $A = \frac{1}{2} \cdot r \cdot C$ describe the relationships in the table? Explain your reasoning.

Solution

1. No. Dividing the area by the circumference gives a different answer every time.
2. Yes. When I substitute in values of r , C , and A from the same row of the table, it makes the equation true, or at least it's very close. The measurements were made using rulers that only have so much accuracy. Students needed to round their answers to the nearest ruler marking, or perhaps rounded even less accurately than that. Also, students probably didn't hold the rulers perfectly still or perfectly straight.

Minimal Tier 1 response:

- Work is complete and correct.
- In verifying the equation, at least two sets of values are checked, or an argument is made about why $\frac{1}{2} \cdot r \cdot C$ is equivalent to πr^2
- Sample:
 1. No. $50 \div 25 = 2$, $201 \div 50 \approx 4$.
 2. Yes. Trying different sets of numbers, I get $50 = \frac{1}{2} \cdot 4 \cdot 25$ which is $50 = 50$, and $201 = \frac{1}{2} \cdot 8 \cdot 50$ which is $201 = 200$. Even though the two sides aren't exactly equal, this can be explained by slight measurement error.

Tier 2 response:

- Work shows general conceptual understanding and mastery, with some errors.

- Sample errors: reasoning in part a is not sufficiently explained; concluding that the equation does not describe the relationship because correctly substituting values results in equations that are technically not true like $201 = 200$.

Tier 3 response:

- Significant errors in work demonstrate lack of conceptual understanding or mastery.
- Sample errors: conclusion that the area and circumference are in a proportional relationship; no visible effort to check whether the given equation described the relationship.

Aligned Standards

7.G.B.4

Problem 6

Watch for students accidentally using the inner 3-unit lengths as part of the perimeter of the figure. Some students may have trouble recognizing the top left as a quarter-circle. Direct these students to the phrasing “part of a circle” in the problem.

Statement

This figure is made from part of a circle and part of a square.

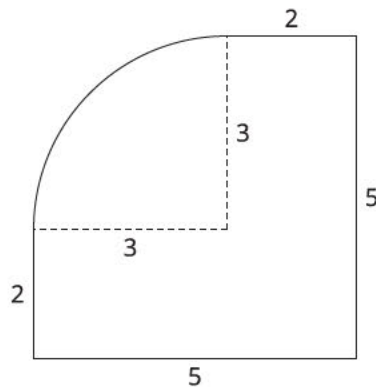

1. What is the perimeter of this figure, to the nearest unit?
2. What is the area of this figure, to the nearest square unit?

Solution

1. 19 units (The quarter-circle's perimeter is $\frac{1}{4} \cdot 2 \cdot \pi \cdot 3$ units. The rest of the perimeter is 14 units. The total perimeter, rounded to the nearest unit, is 19 units.)
2. 23 square units (The quarter-circle's area is $\frac{1}{4} \cdot \pi \cdot 3^2$ square units. The rest of the area is 16 square units. The total area is approximately 23 square units.)

Aligned Standards

7.G.B.4

Problem 7

In this problem, students must identify the proportional relationship between gallons of paint and area of a circular pool. Then the formula for the area of a circle is needed to calculate how much paint is needed to paint the floor of the pool. Finally, the student must interpret the result in context to determine the correct number of cans needed. The same answer will come from any approximation students use for π .

Statement

A painter needs to paint the bottom of a circular pool. The pool has a radius of 30 feet.

A store sells 5-gallon cans of paint. One gallon of paint covers 300 square feet.

What is the smallest number of 5-gallon cans the painter must buy to cover the bottom of the pool? Explain or show your reasoning.

Solution

2 cans. The pool's size is $\pi \cdot 30^2$, just over 2,827 square feet. Each gallon of paint covers 300 square feet; each can of paint covers 1,500 square feet. The number of gallons needed is given by

$$\frac{\pi \cdot 30^2}{1,500} \approx 1.9$$

Because you cannot buy 0.9 of a gallon, 2 cans will be needed.

Minimal Tier 1 response:

- Work is complete and correct, with complete explanation or justification.
- Sample: The area of the field is $\pi \cdot 30^2$, and each can of paint covers 1,500 square feet and that is not enough. 2 cans cover 3,000 square feet.

Tier 2 response:

- Work shows good conceptual understanding and mastery, with either minor errors or correct work with insufficient explanation or justification.
- Sample errors: correct calculation (about 1.9 cans) but incorrect use of context gives answers of 1 or 1.9 cans; incorrect calculation of the number of square feet per gallon but otherwise correct work, including correct use of contextual rounding; calculation errors, but not errors in formula application, when determining the size of the field or the number of bags; incorrect calculations in determining the number of bags when using a strategy that does not involve dividing.

Tier 3 response:

- Work shows a developing but incomplete conceptual understanding, with significant errors.

- Sample errors: incorrectly determining the area of the pool using circumference, or using 60 as the radius; incorrect type of calculation performed on the cans, such as dividing in reverse order; two or more error types from Tier 2 response.
- Acceptable errors: any response giving the correct area of the pool earns at least a Tier 3 response, regardless of other work. Any response giving an incorrect area of the pool, but correct work on the proportional relationship based on that incorrect area, earns at least a Tier 3 response.

Tier 4 response:

- Work includes major errors or omissions that demonstrate a lack of conceptual understanding and mastery.
- Sample errors: incorrectly determining the area of the pool, along with incorrect work on the proportional or contextual relationship; answer without explanation, regardless of accuracy.

Aligned Standards

7.G.B.4, 7.RP.A.2, 7.RP.A.3

CKMath™
Core Knowledge **MATHEMATICS™**



Lesson
Cool Downs

Lesson 1: How Well Can You Measure?

Cool Down: Examining Relationships

1. The graph shows the height of a plant after a certain amount of time measured in days.

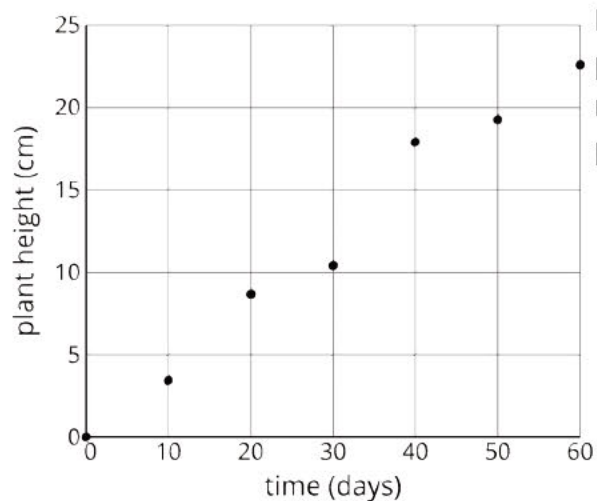

Do you think that there may be a proportional relationship between the number of days and the height of the plant? Explain your reasoning.

2. The graph shows how much snow fell after a certain amount of time measured in hours.

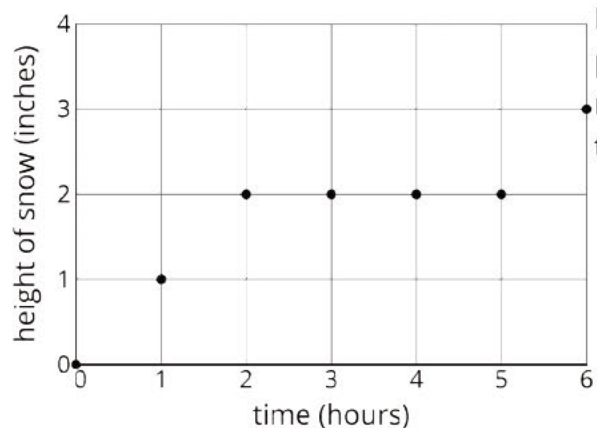

Do you think that there may be a proportional relationship between the number of hours and the amount of snow that fell? Explain your reasoning.

Lesson 2: Exploring Circles

Cool Down: Comparing Circles

Here are two circles. Their centers are A and F .

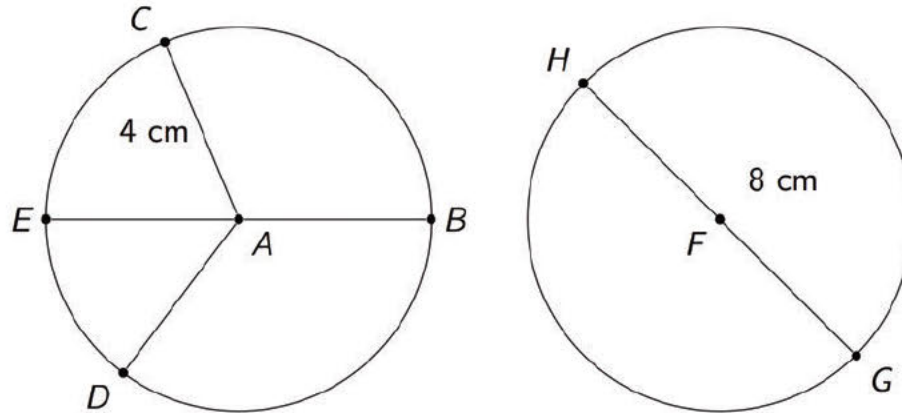

1. What is the same about the two circles? What is different?
2. What is the length of segment AD ? How do you know?
3. On the first circle, what segment is a diameter? How long is it?

Lesson 3: Exploring Circumference

Cool Down: Identifying Circumference and Diameter

Select **all** the pairs that could be reasonable approximations for the diameter and circumference of a circle. Explain your reasoning.

1. 5 meters and 22 meters.
2. 19 inches and 60 inches.
3. 33 centimeters and 80 centimeters.

Lesson 4: Applying Circumference

Cool Down: Circumferences of Two Circles

Circle A has a diameter of 9 cm. Circle B has a radius of 5 cm.

1. Which circle has the larger circumference?
2. About how many centimeters larger is it?

Lesson 6: Estimating Areas

Cool Down: The Area of Alberta

Estimate the area of Alberta in square miles. Show your reasoning.



Lesson 7: Exploring the Area of a Circle

Cool Down: Areas of Two Circles

- Circle A has a diameter of approximately 20 inches and an area of 300 in^2 .
- Circle B has a diameter of approximately 60 inches.

Which of these could be the area of Circle B? Explain your reasoning.

1. About 100 in^2
2. About 300 in^2
3. About 900 in^2
4. About $2,700 \text{ in}^2$

Lesson 8: Relating Area to Circumference

Cool Down: A Circumference of 44

A circle's circumference is approximately 44 cm. Complete each statement using one of these values:

7, 11, 14, 22, 88, 138, 154, 196, 380, 616.

1. The circle's diameter is approximately _____ cm.
2. The circle's radius is approximately _____ cm.
3. The circle's area is approximately _____ cm^2 .

Lesson 9: Applying Area of Circles

Cool Down: Area of an Arch

Here is a picture that shows one side of a child's wooden block with a semicircle cut out at the bottom.

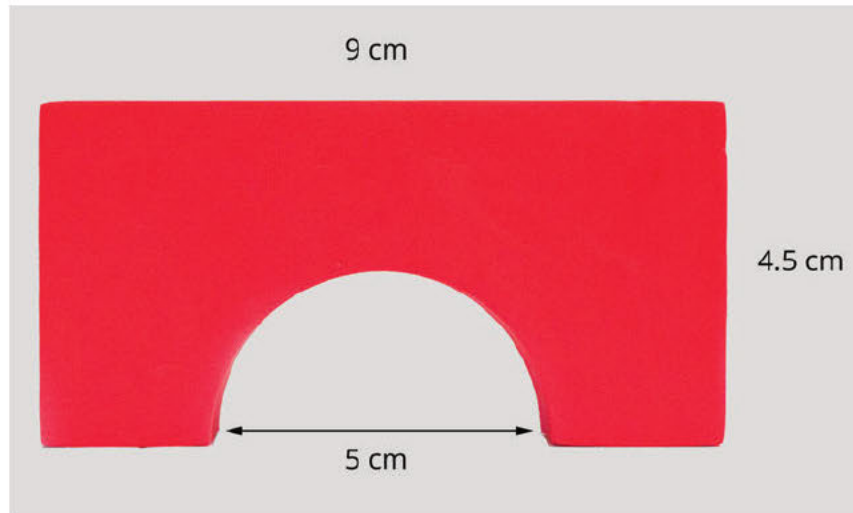

Find the area of the side. Explain or show your reasoning.

Lesson 10: Distinguishing Circumference and Area

Cool Down: Measuring a Circular Lawn

A circular lawn has a row of bricks around the edge. The diameter of the lawn is about 40 feet.

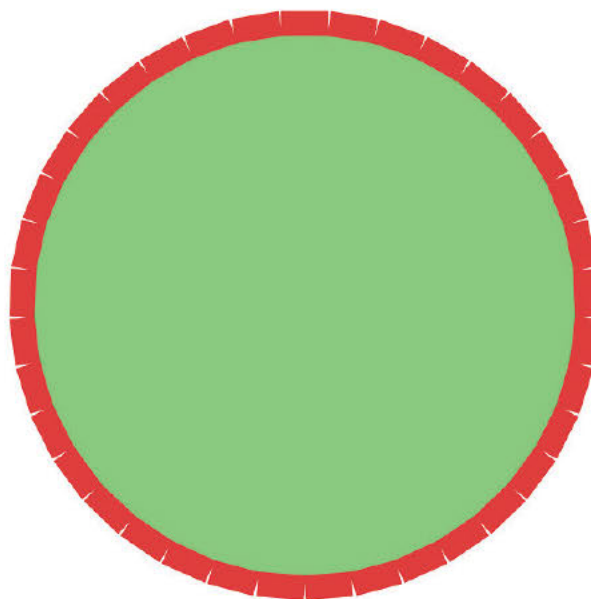

1. Which is the best estimate for the amount of grass in the lawn?
 - a. 125 feet
 - b. 125 square feet
 - c. 1,250 feet
 - d. 1,250 square feet
2. Which is the best estimate for the total length of the bricks?
 - a. 125 feet
 - b. 125 square feet
 - c. 1,250 feet
 - d. 1,250 square feet

CKMath™
Core Knowledge **MATHEMATICS™**



Instructional
Masters

Instructional Masters for Measuring Circles

address	title	students per copy	written on?	requires cutting?	card stock recommended?	color paper recommended?
Activity Grade7.3.7.2	Estimating Areas of Circles	12	yes	no	no	no
Activity Grade7.3.1.2	Perimeter of a Square	1	no	no	no	no
Activity Grade7.3.10.2	Card Sort: Circle Problems	2	no	yes	no	yes
Activity Grade7.3.2.2	Sorting Round Objects	2	no	yes	no	yes

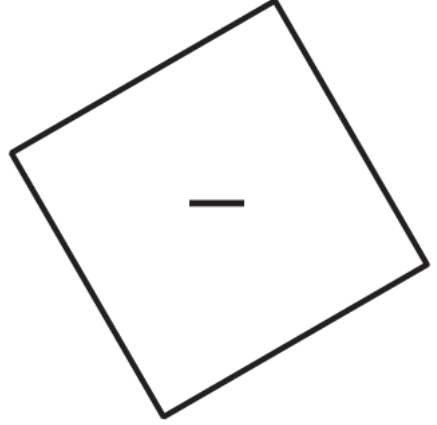
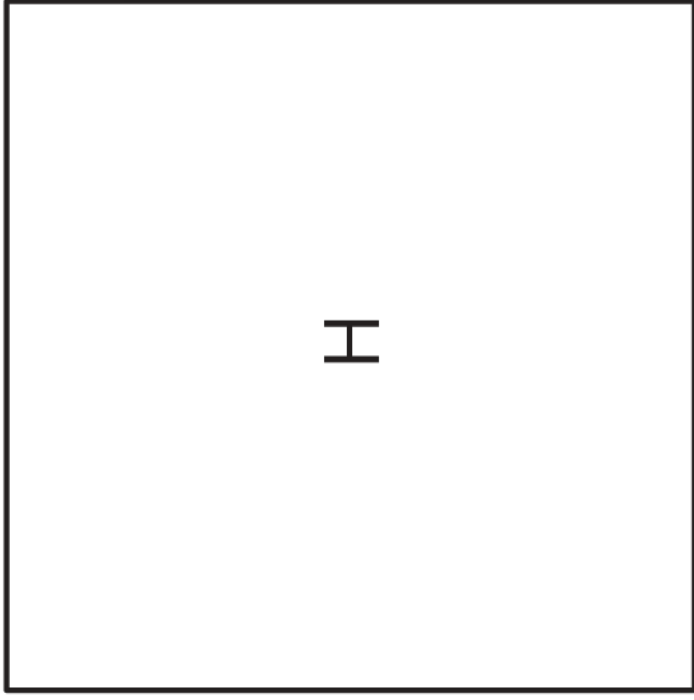
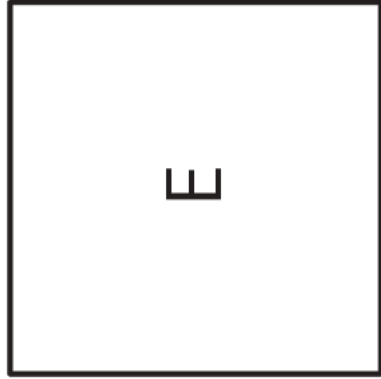
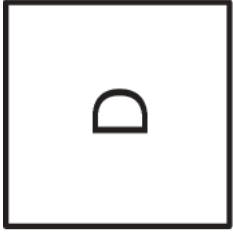
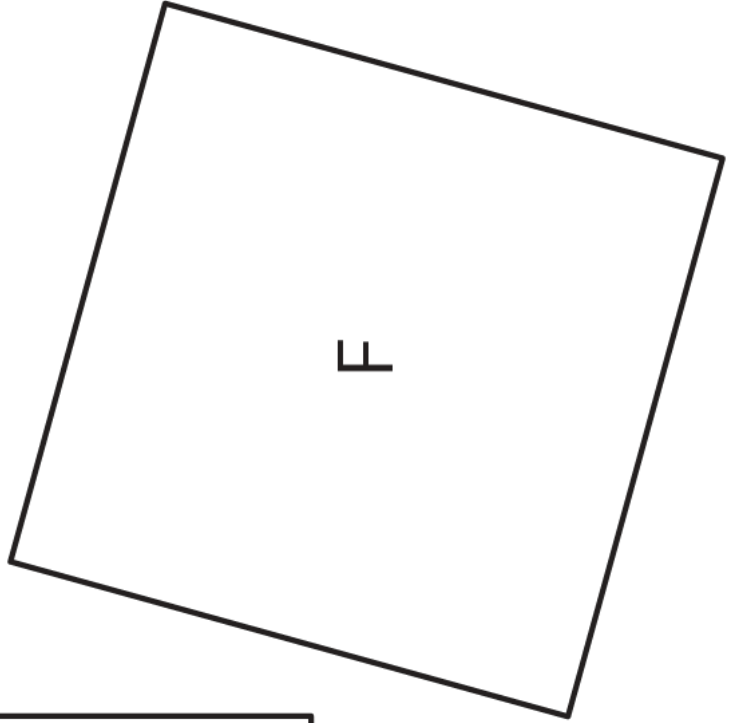
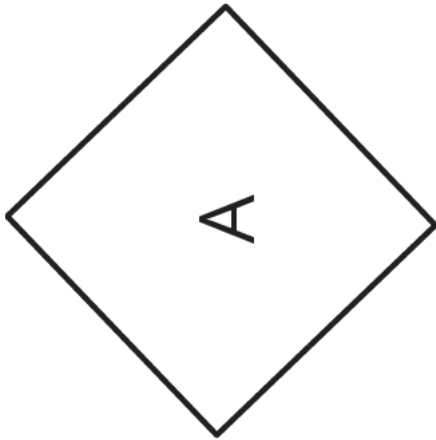

7.3.2.2 Sorting Round Objects.

Sorting Round Objects

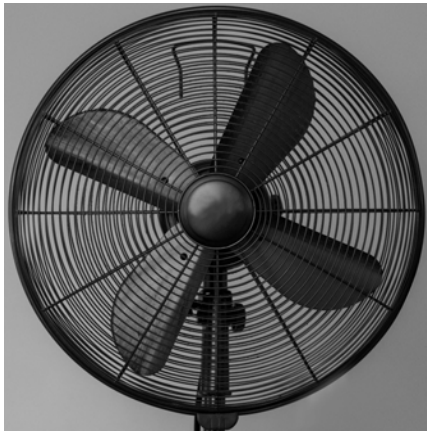

Fan Cover

Sorting Round Objects



Wagon Wheel

Sorting Round Objects



Utility Hole Cover

Sorting Round Objects



Airplane Propeller

Sorting Round Objects



Bike Wheel

Sorting Round Objects

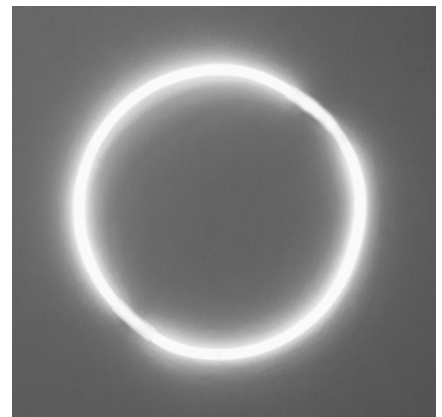

Glow Necklace

Sorting Round Objects

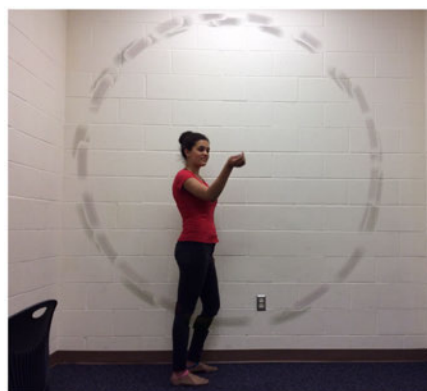

Yo-yo Trick

Sorting Round Objects



Dartboard

Sorting Round Objects



Grill

7.3.2.2 Sorting Round Objects.

Sorting Round Objects

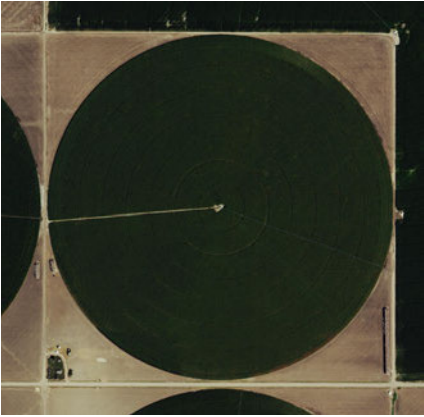

Center Pivot Irrigation

Sorting Round Objects



Boiled Egg

Sorting Round Objects



Basketball

Sorting Round Objects



Clock

Sorting Round Objects



Rug

Sorting Round Objects



Platter

Sorting Round Objects

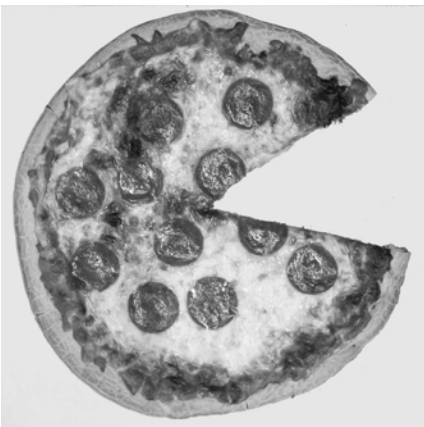

Pizza

Sorting Round Objects



Speedometer

Sorting Round Objects

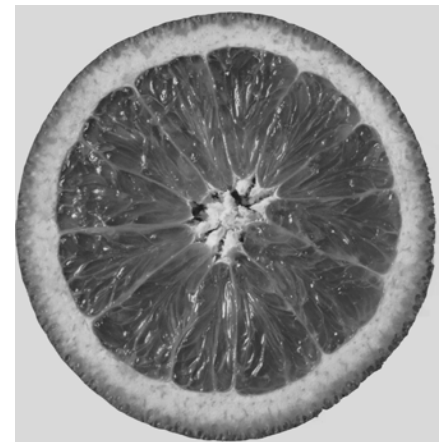

Orange Slice

7.3.7.2 Estimating Areas of Circles.

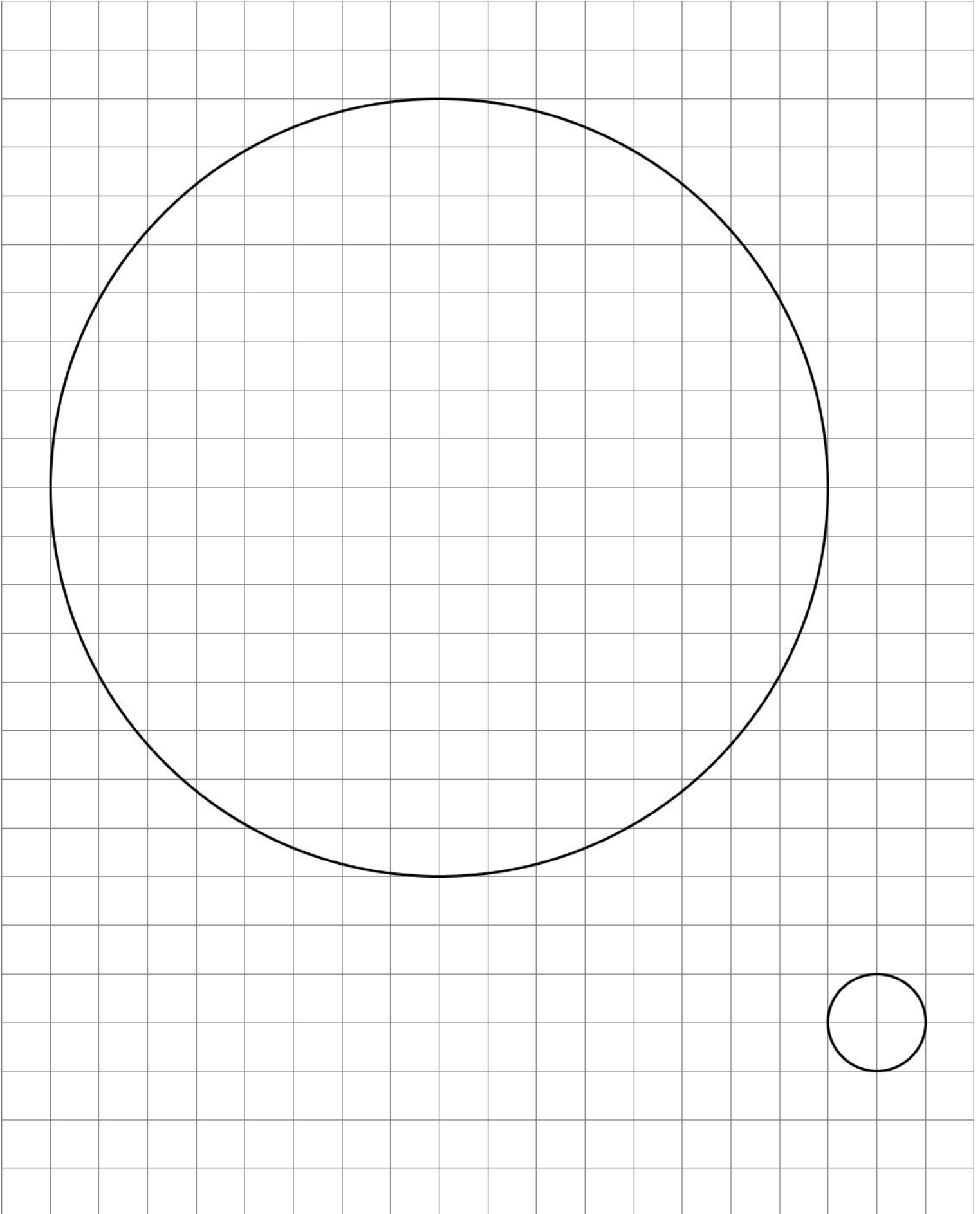

7.3.7.2 Estimating Areas of Circles.

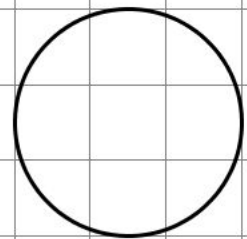
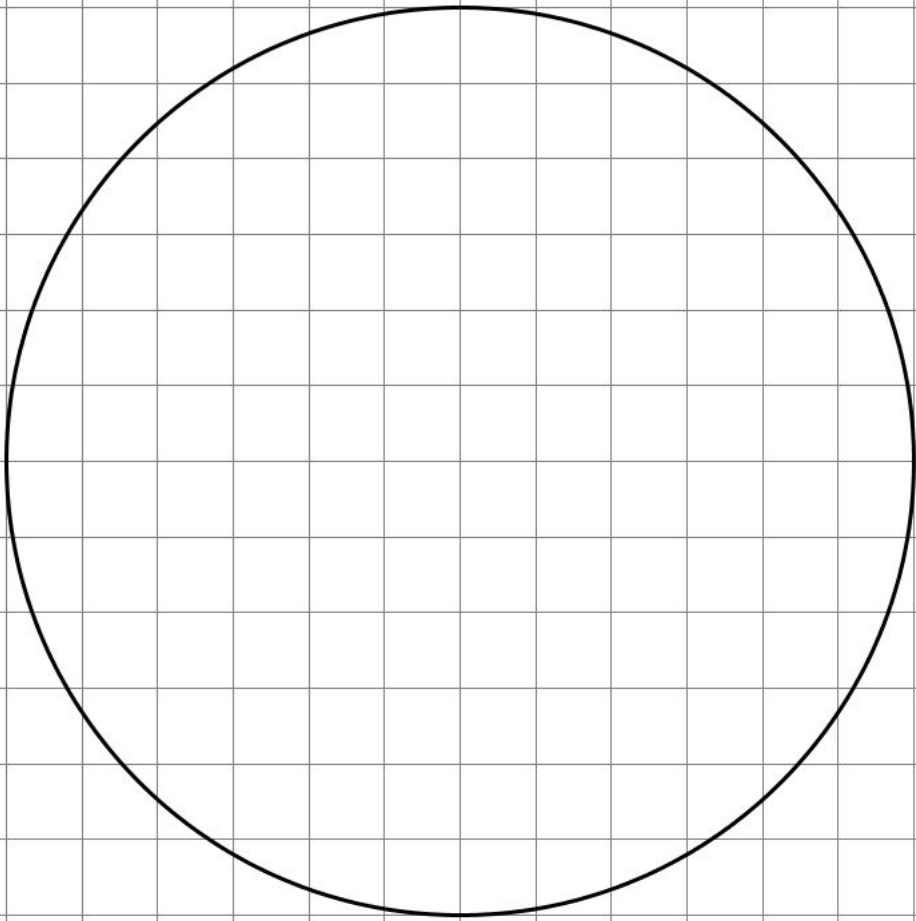

7.3.7.2 Estimating Areas of Circles.

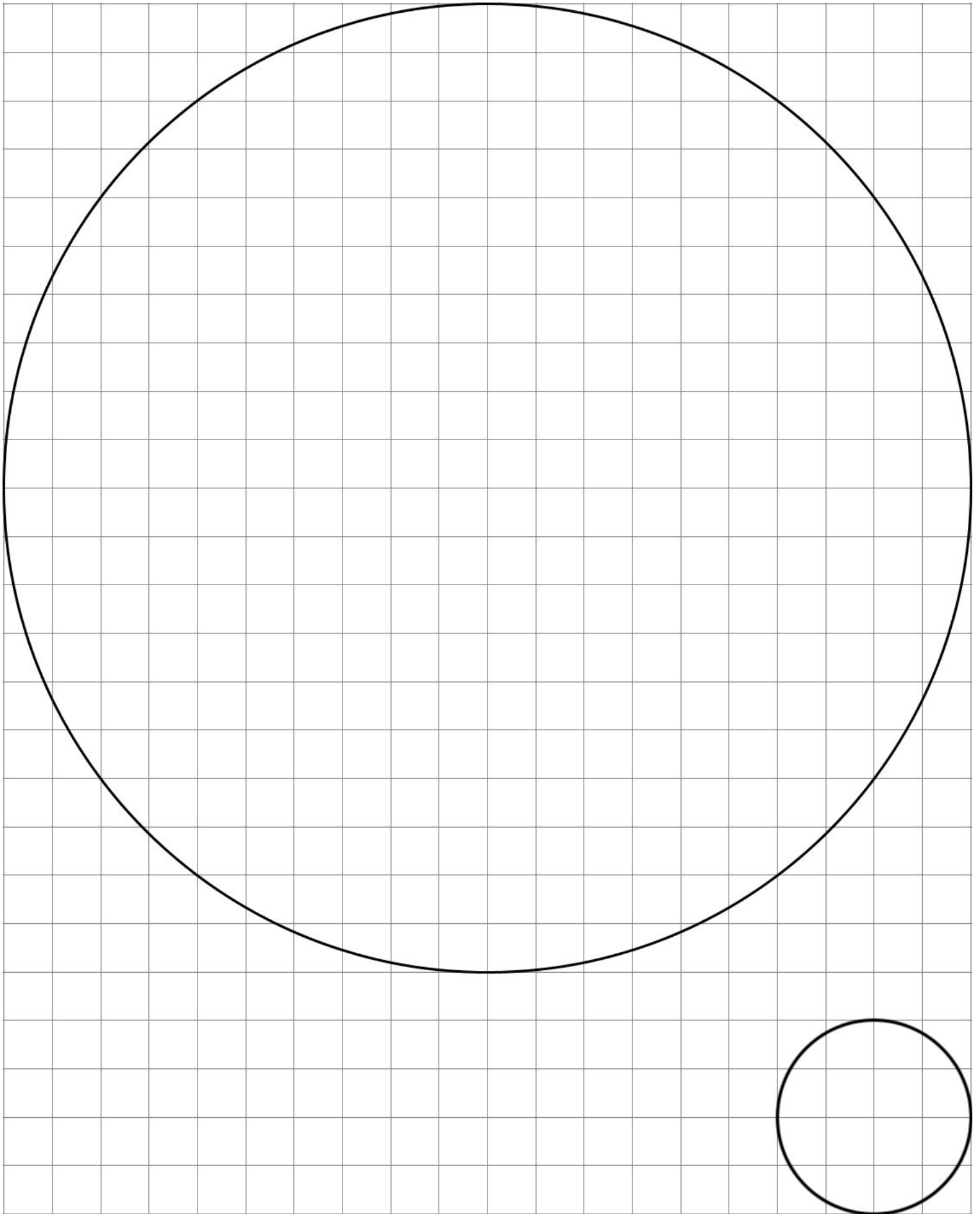

7.3.7.2 Estimating Areas of Circles.

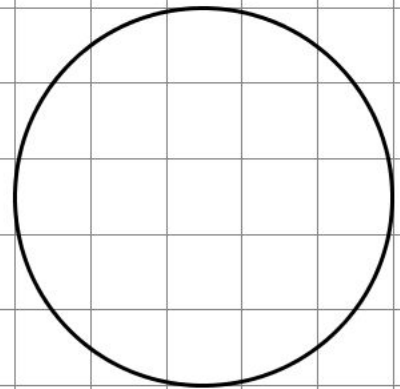
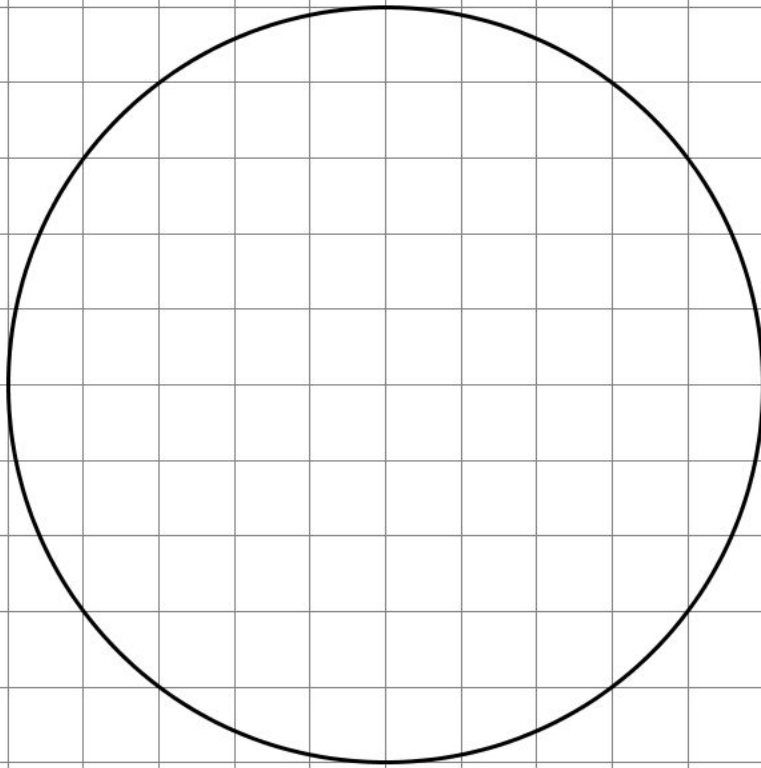

7.3.7.2 Estimating Areas of Circles.

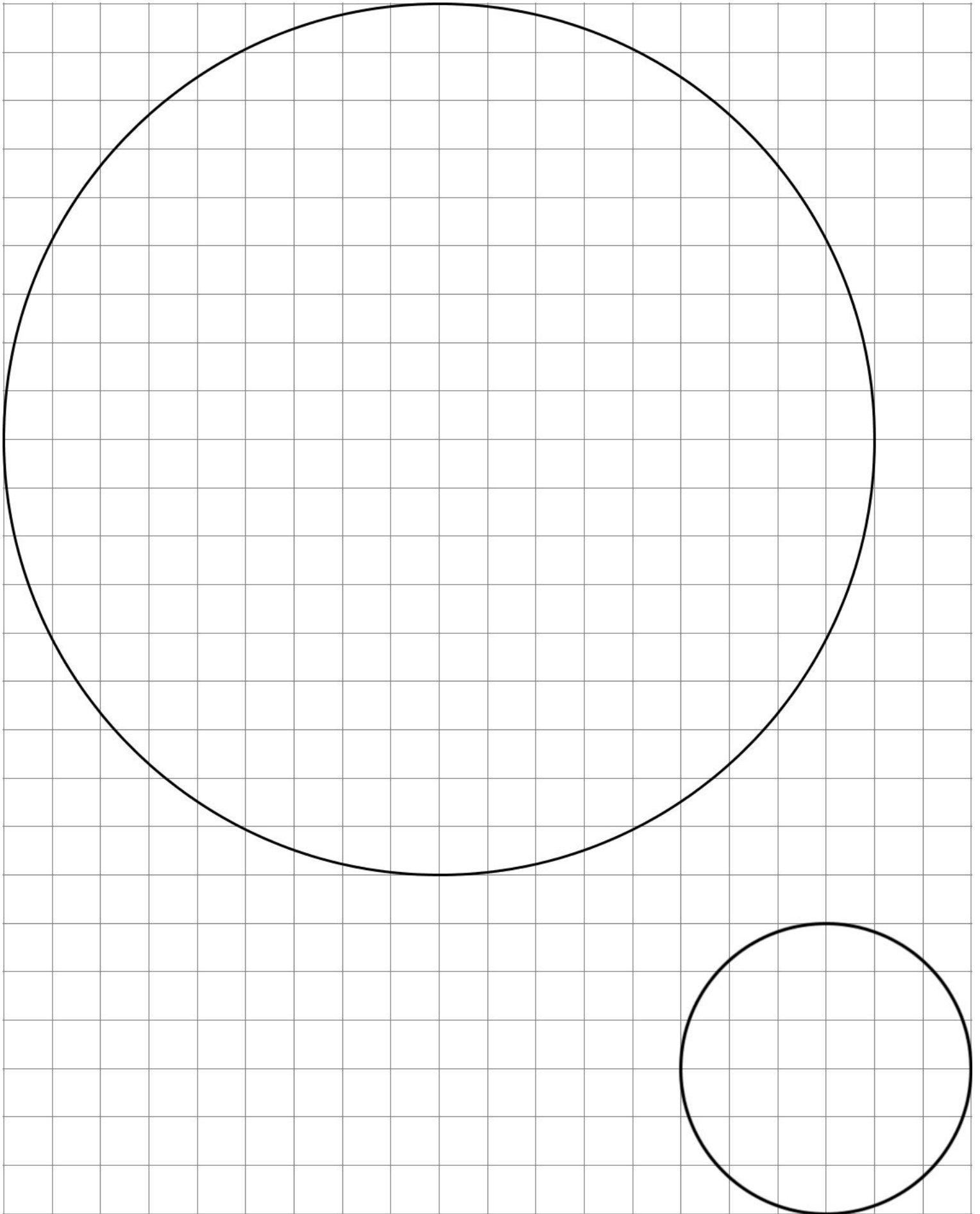

7.3.7.2 Estimating Areas of Circles.

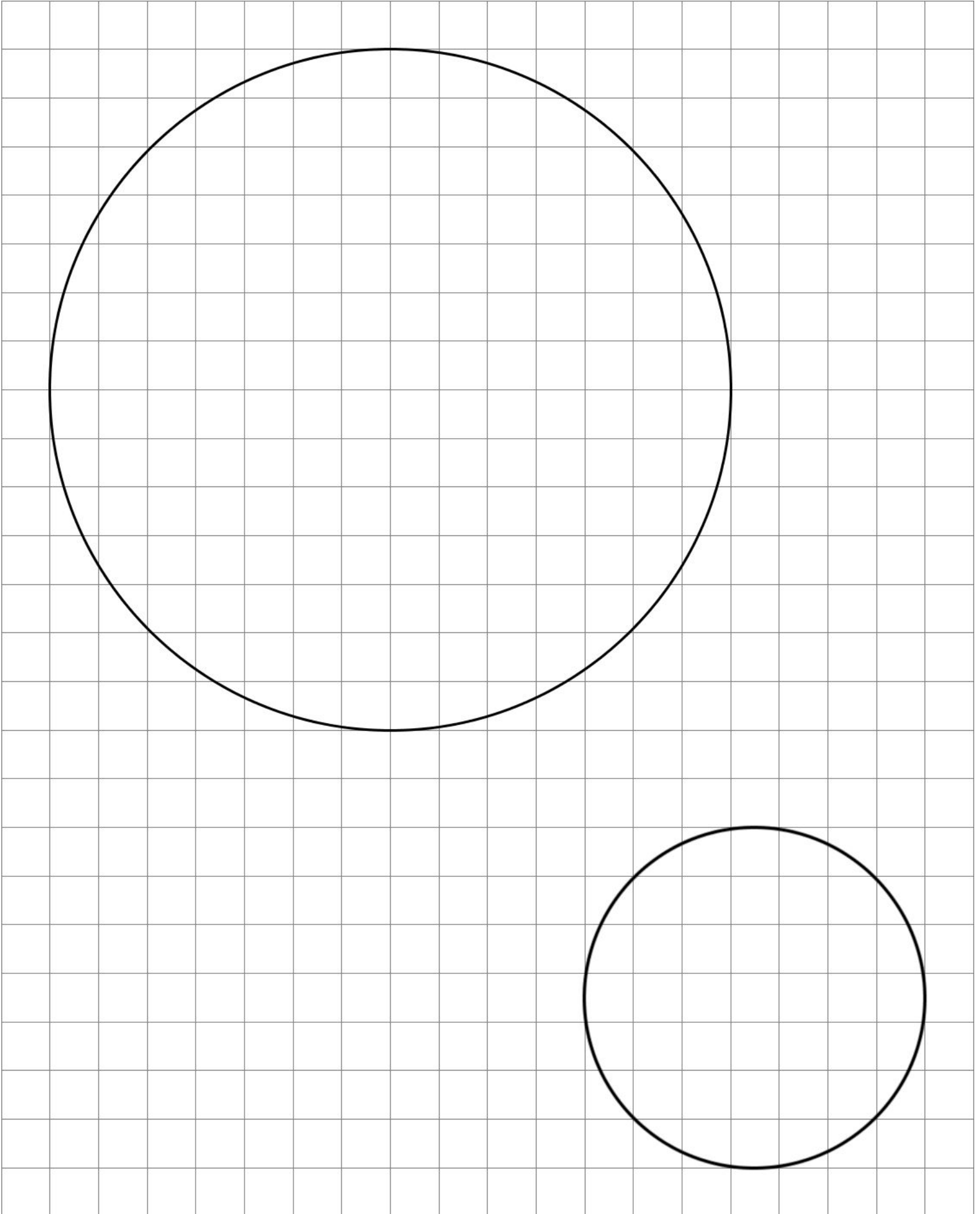

7.3.10.2 Card Sort: Circle Problems.

Card Sort: Circle Problems

Question 1

How much fabric is needed
for a round table cloth?

Card Sort: Circle Problems

Question 2

How fast do you go when
riding on a Ferris wheel?

Card Sort: Circle Problems

Question 3

How much green space is there
inside a traffic roundabout?

Card Sort: Circle Problems

Question 4

How many square inches of
cheese fit on a slice of pizza?

Card Sort: Circle Problems

Question 5

How many times must a horse go
around a horse walker to walk 1 mile?

Card Sort: Circle Problems

Question 6

How many feet are traveled by a person
riding once around a merry-go-round?

Card Sort: Circle Problems

Question 7

How much room is there
to spread frosting on a cookie?

Card Sort: Circle Problems

Question 8

How far does a unicycle move when
the wheel makes 5 full rotations?

Credits

CKMath K–8 was originally developed by Open Up Resources and authored by Illustrative Mathematics, <https://www.illustrativemathematics.org>, and is copyrighted as 2017–2019 by Open Up Resources. It is licensed under the Creative Commons Attribution 4.0 International License (CC BY 4.0). The Open Up Resources K–8 Math Curriculum is available at: <https://www.openupresources.org/math-curriculum/>.

Adaptations and updates to the IM K–8 Math English language learner supports are copyright 2019 by Open Up Resources and licensed under the Creative Commons Attribution 4.0 International License (CC BY 4.0),

Adaptations and updates to IM K–8 Math are copyright 2019 by Illustrative Mathematics, including the additional English assessments marked as "B", and the Spanish translation of assessments marked as "B". These adaptations and updates are licensed under the Creative Commons Attribution 4.0 International License (CC BY 4.0).

This particular work is based on additional work of the Core Knowledge® Foundation (www.coreknowledge.org) made available through licensing under a Creative Commons Attribution-NonCommercial-ShareAlike 4.0 International License.

Illustration and Photo Credits

Ivan Pestic / Cover Illustrations

Illustrative Math K–8 / Cover Image, all interior illustrations, diagrams, and pictures / Copyright 2019 / Licensed under the Creative Commons Attribution 4.0 International License (CC BY 4.0).

These materials include public domain images or openly licensed images that are copyrighted by their respective owners, unless otherwise noted/credited. Openly licensed images remain under the terms of their respective licenses.



CKMath™
Core Knowledge **MATHEMATICS™**

Editorial Director
Richard B. Talbot

CKMath™
Core Knowledge MATHEMATICS™

A comprehensive program for mathematical skills and concepts
as specified in the **Core Knowledge Sequence**
(content and skill guidelines for Grades K–8).

Core Knowledge MATHEMATICS™
units at this level include:

Scale Drawings
Introducing Proportional Relationships
Measuring Circles
Proportional Relationships and Percentages
Rational Number Arithmetic
Expressions, Equations, and Inequalities
Angles, Triangles, and Prisms
Probability and Sampling
Putting It All Together

www.coreknowledge.org

Core Knowledge Curriculum Series™