

Introducing Ratios

Teacher Guide

Using Recipes



Unit Prices

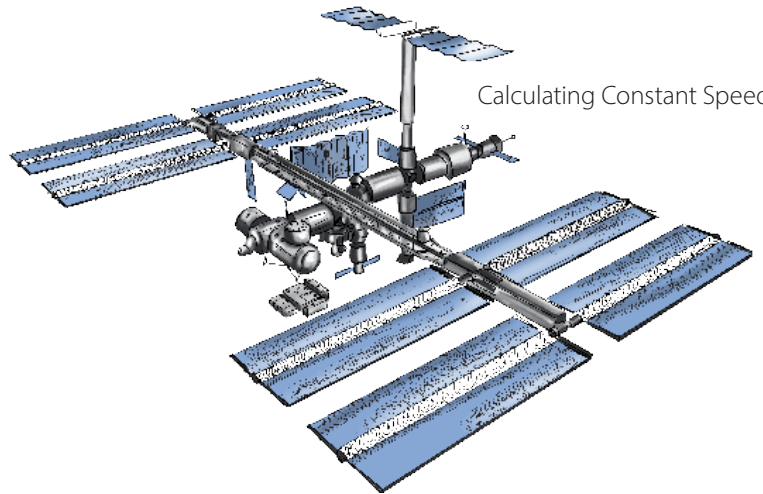

Calculating Constant Speed

Solving Fermi Problems



The Recipe



How do we fix our mistake?



Describing Ratios Using Illustrations

Creative Commons Licensing

This work is licensed under a Creative Commons Attribution-NonCommercial-ShareAlike 4.0 International License.



You are free:

to Share—to copy, distribute, and transmit the work

to Remix—to adapt the work

Under the following conditions:

Attribution—You must attribute the work in the following manner:

CKMath 6–8 was originally developed by Open Up Resources and authored by Illustrative Mathematics, <https://www.illustrativemathematics.org>, and is copyrighted as 2017–2019 by Open Up Resources. It is licensed under the Creative Commons Attribution 4.0 International License (CC BY 4.0). The Open Up Resources 6–8 Math Curriculum is available at: <https://www.openupresources.org/math-curriculum/>.

Adaptations and updates to the IM 6–8 Math English language learner supports and the additional English assessments marked as "B" are copyright 2019 by Open Up Resources and licensed under the Creative Commons Attribution 4.0 International License (CC BY 4.0).

Adaptations and updates to the IM K–8 Math Spanish translation of assessments marked as "B" are copyright 2019 by Illustrative Mathematics. These adaptations and updates are licensed under the Creative Commons Attribution 4.0 International License (CC BY 4.0).

This particular work is based on additional work of the Core Knowledge® Foundation (www.coreknowledge.org) made available through licensing under a Creative Commons Attribution-Non Commercial-Share Alike 4.0 International License. This does not in any way imply that the Core Knowledge Foundation endorses this work.

Noncommercial—You may not use this work for commercial purposes.

Share Alike—If you alter, transform, or build upon this work, you may distribute the resulting work only under the same or similar license to this one.

With the understanding that:

For any reuse or distribution, you must make clear to others the license terms of this work. The best way to do this is with a link to this web page:

<https://creativecommons.org/licenses/by-nc-sa/4.0/>

Copyright © 2023 Core Knowledge Foundation

www.coreknowledge.org

All Rights Reserved.

Core Knowledge®, Core Knowledge Curriculum Series™, Core Knowledge Math™ and CKMath™ are trademarks of the Core Knowledge Foundation.

Trademarks and trade names are shown in this book strictly for illustrative and educational purposes and are the property of their respective owners. References herein should not be regarded as affecting the validity of said trademarks and trade names.

ISBN: 979-8-88970-875-9

Introducing Ratios

Table of Contents

Introduction: Unit Narrative	1
Student Learning Targets	5
Terminology	9
Required Materials	10
Lesson Plans and Student Task Statements	
Section 1: Lessons 1–2 What are Ratios?	11
Section 2: Lessons 3–5 Equivalent Ratios	44
Section 3: Lessons 6–10 Representing Equivalent Ratios ...	90
Section 4: Lessons 11–14 Solving Ratio & Rate Problems ..	168
Section 5: Lessons 15–16 Part-part-whole Ratios	229
Let’s Put It to Work: Lesson 17 A Fermi Problem	264
Teacher Resources	274
Family Support Materials	
Unit Assessments	
Assessment Answer Keys	
Cool Downs (Lesson-level Assessments)	
Instructional Masters	



Introducing Ratios Teacher Guide

Core Knowledge Mathematics™

Introducing Ratios

Unit Narrative

Work with ratios in grade 6 draws on earlier work with numbers and operations. In elementary school, students worked to understand, represent, and solve arithmetic problems involving quantities with the same units. In grade 4, students began to use two-column tables, e.g., to record conversions between measurements in inches and yards. In grade 5, they began to plot points on the coordinate plane, building on their work with length and area. These early experiences were a brief introduction to two key representations used to study relationships between quantities, a major focus of work that begins in grade 6 with the study of ratios.

Starting in grade 3, students worked with relationships that can be expressed in terms of ratios and rates (e.g., conversions between measurements in inches and in yards), however, they did not use these terms. In grade 4, students studied multiplicative comparison. In grade 5, they began to interpret multiplication as scaling, preparing them to think about simultaneously scaling two quantities by the same factor. They learned what it means to divide one whole number by another, so they are well equipped to consider the quotients $\frac{a}{b}$ and $\frac{b}{a}$ associated with a ratio $a : b$ for non-zero whole numbers a and b .

In this unit, students learn that a ratio is an association between two quantities, e.g., “1 teaspoon of drink mix to 2 cups of water.” Students analyze contexts that are often expressed in terms of ratios, such as recipes, mixtures of different paint colors, constant speed (an association of time measurements with distance measurements), and uniform pricing (an association of item amounts with prices).

One of the principles that guided the development of these materials is that students should encounter examples of a mathematical concept in various contexts before the concept is named and studied as an object in its own right. The development of ratios, equivalent ratios, and unit rates in this unit and the next unit is in accordance with that principle. In this unit, equivalent ratios are first encountered in terms of multiple batches of a recipe and “equivalent” is first used to describe a perceivable sameness of two ratios, for example, two mixtures of drink mix and water taste the same or two mixtures of red and blue paint are the same shade of purple. Building on these experiences, students analyze situations involving both discrete and continuous quantities, and involving ratios of quantities with units that are the same and that are different. Several lessons later, *equivalent* acquires a more precise meaning (MP6): All ratios that are equivalent to $a : b$ can be made by multiplying both a and b by the same non-zero number (note that students are not yet considering negative numbers).

This unit introduces *discrete diagrams* and *double number line diagrams*, representations that students use to support thinking about equivalent ratios before their work with tables of equivalent ratios.

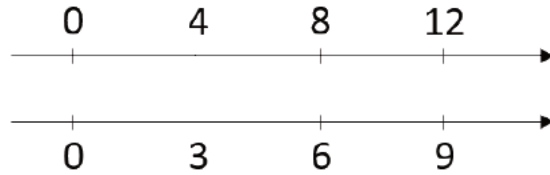
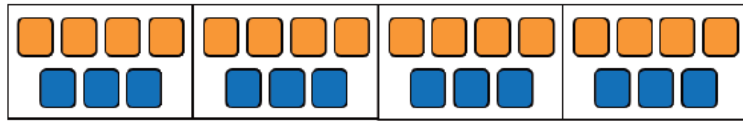

Initially, discrete diagrams are used because they are similar to the kinds of diagrams students might have used to represent multiplication in earlier grades. Next come double number line diagrams. These can be drawn more quickly than discrete diagrams, but are more similar to tables while allowing reasoning based on the lengths of intervals on the number lines. After some work with double number line diagrams, students use tables to represent equivalent ratios. Because equivalent pairs of ratios can be written in any order in a table and there is no need to attend to the distance between values, tables are the most flexible and concise of the three representations for equivalent ratios, but they are also the most abstract. Use of tables to represent equivalent ratios is an important stepping stone toward use of tables to represent linear and other functional relationships in grade 8 and beyond. Because of this, students should learn to use tables to solve all kinds of ratio problems, but they should always have the option of using discrete diagrams and double number line diagrams to support their thinking.

When a ratio involves two quantities with the same units, we can ask and answer questions about ratios of each quantity and the total of the two. Such ratios are sometimes called “part-part-whole” ratios and are often used to introduce ratio work. However, students often struggle with them so, in this unit, the study of part-part-whole ratios occurs at the end. (Note that tape diagrams are reserved for ratios in which all quantities have the same units.) The major use of part-part-whole ratios occurs with certain kinds of percentage problems, which comes in the next unit.

On using the terms ratio, rate, and proportion. In these materials, a *quantity* is a measurement that is or can be specified by a number and a unit, e.g., 4 oranges, 4 centimeters, “my height in feet,” or “my height” (with the understanding that a unit of measurement will need to be chosen). The term *ratio* is used to mean an association between two or more quantities and the fractions $\frac{a}{b}$ and $\frac{b}{a}$ are never called ratios. Ratios of the form $1 : \frac{b}{a}$ or $\frac{a}{b} : 1$ (which are equivalent to $a : b$) are highlighted as useful but $\frac{a}{b}$ and $\frac{b}{a}$ are not identified as *unit rates* for the ratio $a : b$ until the next unit. However, the meanings of these fractions in contexts is very carefully developed. The word “per” is used with students in interpreting a unit rate in context, as in “\$3 per ounce,” and “at the same rate” is used to signify a situation characterized by equivalent ratios.

In the next unit, students learn the term “unit rate” and that if two ratios $a : b$ and $c : d$ are equivalent, then the unit rates $\frac{a}{b}$ and $\frac{c}{d}$ are equal.

The terms *proportion* and *proportional relationship* are not used anywhere in the grade 6 materials. A proportional relationship is a collection of equivalent ratios, and such collections are objects of study in grade 7. In high school—after their study of ratios, rates, and proportional relationships—students discard the term “unit rate,” referring to a to b , $a : b$, and $\frac{a}{b}$ as “ratios.”

Progression of Disciplinary Language

In this unit, teachers can anticipate students using language for mathematical purposes such as interpreting, explaining, and comparing. Throughout the unit, students will benefit from routines designed to grow robust disciplinary language, both for their own sense-making and for building shared understanding with peers. Teachers can formatively assess how students are using language in these ways, particularly when students are using language to:

Interpret

- ratio notation (Lesson 1)
- different representations of ratios (Lesson 6)
- situations involving equivalent ratios (Lesson 8)
- situations with different rates (Lesson 9)
- tables of equivalent ratios (Lessons 11 and 12)
- questions about situations involving ratios (Lesson 17)

Explain

- features of ratio diagrams (Lesson 2)
- reasoning about equivalence (Lesson 4)
- reasoning about equivalent rates (Lesson 10)
- reasoning with reference to tables (Lesson 14)
- reasoning with reference to tape diagrams (Lesson 15)

Compare

- situations with and without equivalent ratios (Lesson 3)
- representations of ratios (Lessons 6 and 13)
- situations with different rates (Lessons 9 and 12)
- situations with same rates and different rates (Lesson 10)
- representations of ratio and rate situations (Lesson 16)

In addition, students are expected to describe and represent ratio associations, represent doubling and tripling of quantities in a ratio, represent equivalent ratios, justify whether ratios are or aren't equivalent and why information is needed to solve a ratio problem, generalize about equivalent ratios and about the usefulness of ratio representations, and critique representations of ratios.

The table shows lessons where new terminology is first introduced, including when students are expected to understand the word or phrase receptively and when students are expected to produce the word or phrase in their own speaking or writing. Terms from the glossary appear bolded. Teachers should continue to support students' use of a new term in the lessons that follow where it was first introduced.

Learning Targets

Introducing Ratios

Lesson 1: Introducing Ratios and Ratio Language

- I can write or say a sentence that describes a ratio.
- I know how to say words and numbers in the correct order to accurately describe the ratio.

Lesson 2: Representing Ratios with Diagrams

- I can draw a diagram that represents a ratio and explain what the diagram means.
- I include labels when I draw a diagram representing a ratio, so that the meaning of the diagram is clear.

Lesson 3: Recipes

- I can explain the meaning of equivalent ratios using a recipe as an example.
- I can use a diagram to represent a recipe, a double batch, and a triple batch of a recipe.
- I know what it means to double or triple a recipe.

Lesson 4: Color Mixtures

- I can explain the meaning of equivalent ratios using a color mixture as an example.
- I can use a diagram to represent a single batch, a double batch, and a triple batch of a color mixture.
- I know what it means to double or triple a color mixture.

Lesson 5: Defining Equivalent Ratios

- If I have a ratio, I can create a new ratio that is equivalent to it.
- If I have two ratios, I can decide whether they are equivalent to each other.

Lesson 6: Introducing Double Number Line Diagrams

- I can label a double number line diagram to represent batches of a recipe or color mixture.
- When I have a double number line that represents a situation, I can explain what it means.

Lesson 7: Creating Double Number Line Diagrams

- I can create a double number line diagram and correctly place and label tick marks to represent equivalent ratios.
- I can explain what the word per means.

Lesson 8: How Much for One?

- I can choose and create diagrams to help me reason about prices.
- I can explain what the phrase “at this rate” means, using prices as an example.
- If I know the price of multiple things, I can find the price per thing.

Lesson 9: Constant Speed

- I can choose and create diagrams to help me reason about constant speed.
- If I know an object is moving at a constant speed, and I know two of these things: the distance it travels, the amount of time it takes, and its speed, I can find the other thing.

Lesson 10: Comparing Situations by Examining Ratios

- I can decide whether or not two situations are happening at the same rate.
- I can explain what it means when two situations happen at the same rate.
- I know some examples of situations where things can happen at the same rate.

Lesson 11: Representing Ratios with Tables

- If I am looking at a table of values, I know where the rows are and where the columns are.
- When I see a table representing a set of equivalent ratios, I can come up with numbers to make a new row.
- When I see a table representing a set of equivalent ratios, I can explain what the numbers mean.

Lesson 12: Navigating a Table of Equivalent Ratios

- I can solve problems about situations happening at the same rate by using a table and finding a “1” row.
- I can use a table of equivalent ratios to solve problems about unit price.

Lesson 13: Tables and Double Number Line Diagrams

- I can create a table that represents a set of equivalent ratios.
- I can explain why sometimes a table is easier to use than a double number line to solve problems involving equivalent ratios.
- I include column labels when I create a table, so that the meaning of the numbers is clear.

Lesson 14: Solving Equivalent Ratio Problems

- I can decide what information I need to know to be able to solve problems about situations happening at the same rate.
- I can explain my reasoning using diagrams that I choose.

Lesson 15: Part-Part-Whole Ratios

- I can create tape diagrams to help me reason about problems involving a ratio and a total amount.
- I can solve problems when I know a ratio and a total amount.

Lesson 16: Solving More Ratio Problems

- I can choose and create diagrams to help think through my solution.
- I can solve all kinds of problems about equivalent ratios.
- I can use diagrams to help someone else understand why my solution makes sense.

Lesson 17: A Fermi Problem

- I can apply what I have learned about ratios and rates to solve a more complicated problem.
- I can decide what information I need to know to be able to solve a real-world problem about ratios and rates.

lesson	new terminology	
	receptive	productive
6.2.1	ratio __ to __ __ for every __	
6.2.2	diagram	
6.2.3	recipe batch same taste	ratio __ to __ __ for every __
6.2.4	mixture same color check (an answer)	batch
6.2.5	equivalent ratios	
6.2.6	double number line diagram tick marks representation	diagram
6.2.7	per	
6.2.8	unit price how much for 1 at this rate	double number line
6.2.9	meters per second constant speed	
6.2.10	same rate	equivalent ratios
6.2.11	table row column	
6.2.14	calculation	per table
6.2.15	tape diagram parts suppose	

lesson	new terminology	
	receptive	productive
6.2.16		tape diagram

Required Materials

Beakers

Colored pencils

Copies of blackline master

Drink mix

A powder that is mixed with water to create a fruit-flavored or chocolate-flavored drink. Using a sugar-free drink mix is recommended, but *not* a mix that calls for adding a separate sweetener when mixing up the drink.

Empty containers

Food coloring

Graduated cylinders

Graph paper

Markers

Masking tape

Meter sticks

Paper cups

Pre-printed slips, cut from copies of the blackline master

Rulers

Snap cubes

Stopwatches

String

Students' collections of objects

Teacher's collection of objects

Teaspoon

Tools for creating a visual display

Any way for students to create work that can be easily displayed to the class. Examples: chart paper and markers, whiteboard space and markers, shared online drawing tool, access to a document camera.

Water

Section: What are Ratios?

Lesson 1: Introducing Ratios and Ratio Language

Goals

- Comprehend the word “ratio” (in written and spoken language) and the notation $a : b$ (in written language) to refer to an association between quantities.
- Describe (orally and in writing) associations between quantities using the language “For every a of these, there are b of those” and “The ratio of these to those is $a : b$ (or a to b).”

Learning Targets

- I can write or say a sentence that describes a ratio.
- I know how to say words and numbers in the correct order to accurately describe the ratio.

Lesson Narrative

In this lesson, students use collections of objects to make sense of and use **ratio** language. Students see that there are several different ways to describe a situation using ratio language. For example, if we have 12 squares and 4 circles, we can say the ratio of squares to circles is $12 : 4$ and the ratio of circles to squares is 4 to 12. We may also see a structure that prompts us to regroup them and say that there are 6 squares for every 2 circles, or 3 squares for every one circle (MP7).

Expressing associations of quantities in a context—as students will be doing in this lesson—requires students to use ratio language with care (MP6). Making groups of physical objects that correspond with “for every” language is a concrete way for students to make sense of the problem (MP1).

It is important that in this first lesson students have physical objects they can move around. Later, they will draw diagrams that reflect the same structures and learn to reason with and interpret abstract representations like double number line diagrams and tables. Working with objects that can be physically rearranged in the beginning of the unit can help students make sense of increasingly abstract representations they will encounter as the unit progresses. Students will continue to develop ratio language throughout the unit and will learn about equivalent ratios in a future lesson.

Alignments

Building On

- 3.MD.C.6: Measure areas by counting unit squares (square cm, square m, square in, square ft, and improvised units).

Addressing

- 6.RP.A.1: Understand the concept of a ratio and use ratio language to describe a ratio relationship between two quantities. For example, “The ratio of wings to beaks in the bird house at the zoo was 2 : 1, because for every 2 wings there was 1 beak.” “For every vote candidate A received, candidate C received nearly three votes.”

Instructional Routines

- Anticipate, Monitor, Select, Sequence, Connect
- Group Presentations
- MLR7: Compare and Connect
- Think Pair Share

Required Materials

Students’ collections of objects

Teacher’s collection of objects

Tools for creating a visual display

Any way for students to create work that can be easily displayed to the class. Examples: chart

paper and markers, whiteboard space and markers, shared online drawing tool, access to a document camera.

Required Preparation

A few days before this lesson, ask students to bring a personal collection of 10–50 small objects. Examples include rocks, seashells, trading cards, or coins. Bring in your personal collection and display it ahead of time. Think of possible ways to sort your collection. (See the Launch section of the first activity for details.) Prepare a few extra collections for students who don’t bring one.

Student Learning Goals

Let’s describe two quantities at the same time.

1.1 What Kind and How Many?

Warm Up: 5 minutes

In this warm-up, students compare figures and sort them into categories.

Building On

- 3.MD.C.6

Instructional Routines

- Think Pair Share

Launch

Display the image for all to see. Give students 1 minute of quiet think time followed by 2 minutes of partner discussion.

Anticipated Misconceptions

If students struggle to create their own categories, prompt them to consider a specific attribute of the figures, such as the size, color, or shape.

Student Task Statement

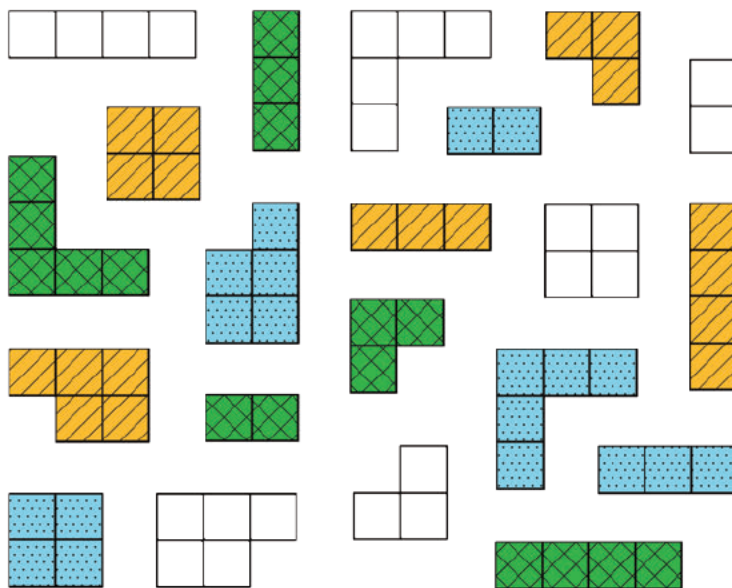

Think of different ways you could sort these figures. What categories could you use? How many groups would you have?

Student Response

Answers vary. Sample responses:

By area: Four groups: 2, 3, 4, and 5 square units

By color: Four groups: blue, green, yellow, and white

By pattern: Four groups: striped, dotted, cross-hatch, and blank

By shape:

- Two groups: rectangles and non-rectangles.
- Three groups: rectangles, two different squares glued together, and L-shapes.
- Four groups: squares, rectangles, two different squares glued together, and L-shapes.
- Seven groups: small, medium, and large rectangles, 2 by 2 squares, small L, big L, and a small and a big square glued together.

Activity Synthesis

Record all the ways students answered the question for all to see. Ask a student to explain how they sorted the figures. Ask if anyone saw it a different way until all the different ways of seeing the

shapes have been shared. Emphasize that the important thing is to describe the way they sorted them clearly enough that everyone agrees that it is a reasonable way to sort them. Tell students we will be looking at different ways of seeing the same set of objects in the next activity.

1.2 The Teacher's Collection

10 minutes

This activity introduces students to ratio language and notation through examples based on a collection of everyday objects. Students learn that a ratio is an association between quantities, and that this association can be expressed in multiple ways.

After discussing examples of ratio language and notation for one way of categorizing the objects in the collection, students write ratios to describe the quantities for another way of categorizing objects in the collection.

As students work, circulate and identify those who:

- Create different categories from the given collection.
- Create categories whose quantities can be rearranged into smaller groups (e.g. 6 A's and 4 B's can be expressed as "for every 3 A's there are 2 B's").
- Express the same ratio in opposite order or by using different words (e.g. "the ratio of A to B is 7 to 3," and "for every 7 A's there are 3 B's").

Have a collection of objects ready to display for the launch. Make sure there are different ways the collection can be sorted. For example, the dinosaurs below can be categorized by color (green, orange, and purple), by the number of legs they stand on (standing on 4 legs or on 2 legs), or by the features along their backs (crest, white stripe, or nothing).



Familiar classroom objects such as binder clips or pattern blocks can also be used to form collections. This picture shows a collection of binder clips that could be categorized by size (small, medium, and large) or by color (black, green, and blue) .

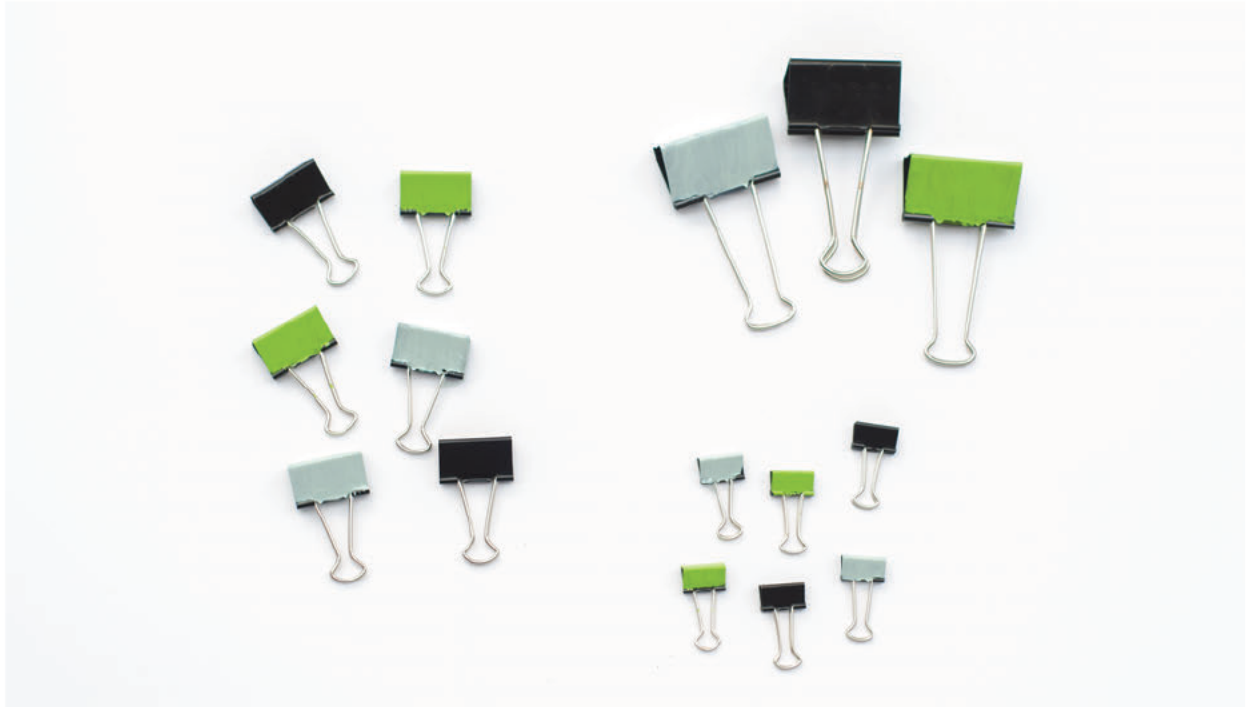

Addressing

- 6.RP.A.1

Instructional Routines

- Anticipate, Monitor, Select, Sequence, Connect

Launch

Display a collection of objects for all to see. Give students 2 minutes of quiet think time to come up with as many different categories for sorting the collection as they can think of. Record students' categories for all to see. Sort the collection into one of the student-suggested categories and count the number of items in each. Record the number of objects in each category and display for all to see. For example:

category A: green	category B: orange	category C: purple
3	2	4

Explain that we can talk about the quantities in the different categories using something called **ratios**. Tell students: "A **ratio** is an association between two or more quantities." We use a colon, or the word "to," between two values we are associating.

Share the following examples (adapt them to suit your collection) and display them for all to see. Keep the examples visible for the duration of the lesson.

- The ratio of purple to orange dinosaurs is 4 to 2.
- The ratio of purple to orange dinosaurs is 4 : 2.
- The ratio of orange to purple dinosaurs is 2 to 4.
- The ratio of orange to purple dinosaurs is 2 : 4

Explain that we can also associate two quantities using the phrase “for every a of these, there are b of those.” Add the following examples to the display.

- For every 3 green dinosaurs there are 4 purple dinosaurs.
- There are 4 purple dinosaurs for every 2 orange dinosaurs.

Finally, find two categories whose items can be rearranged into smaller groups, e.g. 4 purple dinosaurs to 2 orange dinosaurs. Point out that in some cases we can associate the same categories using different numbers. Share the following example and add it to the display.

- For every 2 purple dinosaurs, there is 1 orange dinosaur.



Have students write two or three sentences to describe ratios between the categories they suggested.

Support for Students with Disabilities

Representation: Develop Language and Symbols. Create a display of important terms and vocabulary. Invite students to suggest language or diagrams to include that will support their understanding of: ratio and category.

Supports accessibility for: Conceptual processing; Language

Anticipated Misconceptions

Students may write ratios with no descriptive words. $8 : 2$ is a good start, but part of writing a ratio is stating what those numbers mean. Draw students' attention to the sentence stems in the task statement; encourage them to use those words.

Student Task Statement

1. Think of a way to sort your teacher's collection into two or three categories. Count the items in each category, and record the information in the table.

category name			
category amount			

Pause here so your teacher can review your work.

2. Write at least two sentences that describe **ratios** in the collection. Remember, there are many ways to write a ratio:
 - The ratio of *one category* to *another category* is _____ to _____.
 - The ratio of *one category* to *another category* is _____ : _____.
 - There are _____ of *one category* for every _____ of *another category*.

Student Response

Answers vary depending on the particulars of the teacher's collection and the choices made by students.

Activity Synthesis

Invite several students to share their categories and sentences. Display them for all to see, attending to correct ratio language. Be sure to include students who express the same categories in reverse order, in different words, or with a different set of numbers (which students will later call an equivalent ratio). Leave several sentences displayed for students to see and use as a reference while working on the next task.

1.3 The Student's Collection

20 minutes

In this activity, students write ratios to describe objects in their own collection. They create a display of objects and circulate to look at their classmates' work. Students see that there are several ways to write ratios to describe the same situation.

Addressing

- 6.RP.A.1

Instructional Routines

- Group Presentations
- MLR7: Compare and Connect

Launch

Invite students to share what types of items are in their personal collections. If students did not bring in a collection, pair them with another student, or provide them with an extra collection that you have brought in for that purpose.

Provide access to tools for creating a visual display. Tell students they will pause their work before creating a visual display to get their sentences approved.

Support for English Language Learners

Representing, Conversing: MLR7 Compare and Connect. Use this routine to help students consider audience when preparing to display their work. Display the list of items that should be included on the display and ask students, "what kinds of details could you include on your display to help a reader understand the ratios you've used to describe the objects in your collection?" Record ideas and display for all to see. Examples of these types of details or annotations include: the order in which representations are organized on the display, attaching written notes or details to certain representations, using specific vocabulary or phrases, or using color or arrows to show connections between representations. If time allows, ask students to describe specific examples of additional details that other groups used that helped them to interpret and understand their displays.

Design Principle(s): Maximize meta-awareness; Optimize output

Anticipated Misconceptions

Watch for students simply writing a numerical ratio, such as $3 : 7$, without any descriptive words. Draw their attention to the sentence stems in the task statement.

Student Task Statement

- Sort your collection into three categories. You can experiment with different ways of arranging these categories. Then, count the items in each category, and record the information in the table.

category name			
category amount			

- Write at least two sentences that describe **ratios** in the collection. Remember, there are many ways to write a ratio:

- The ratio of *one category* to *another category* is _____ to _____.
- The ratio of *one category* to *another category* is _____ : _____.
- There are _____ of *one category* for every _____ of *another category*.

Pause here so your teacher can review your sentences.

- Make a visual display of your items that clearly shows one of your statements. Be prepared to share your display with the class.

Student Response

Answers vary.

Are You Ready for More?

- Use two colors to shade the rectangle so there are 2 square units of one color for every 1 square unit of the other color.
- The rectangle you just colored has an area of 24 square units. Draw a different shape that does *not* have an area of 24 square units, but that can also be shaded with two colors in a 2 : 1 ratio. Shade your new shape using two colors.

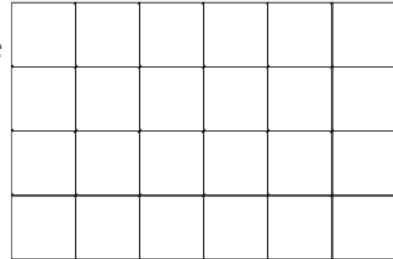

Student Response

- A correct answer will have 16 square units of one color and 8 square units of the other color. Here's one way:

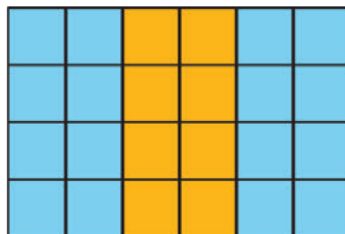

2. Answers vary.

Activity Synthesis

Once students have had enough time to create their displays, circulate through each display and listen to how students describe their ratios.

As students present their displays, point out the various ways that students chose to showcase their work, including different ways to say the same ratio. Ask students who used two sets of numbers to describe the same categories (e.g., 8 to 2 and “4 for every 1”) to demonstrate the two ways of grouping the objects.

Lesson Synthesis

This lesson is all about how to use **ratio** language and notation to describe an association between two or more quantities. Wrap up the lesson by drawing a diagram for all to see of, say, 6 squares and 3 circles.

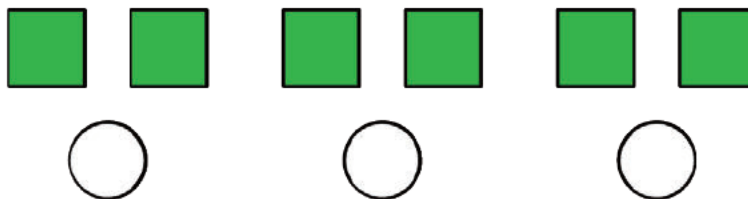

Say, “One way to write this ratio is, there are 6 squares for every 3 circles. What are some other ways to write this ratio?” Some correct options might be:

- The ratio of squares to circles is 6 : 3.
- The ratio of circles to squares is 3 to 6.
- There are 2 squares for every 1 circle.

Display this diagram and the associated sentences the class comes up with somewhere in the classroom so students can refer back to the correct ratio and rate language during subsequent lessons.

Consider posing some more general questions, such as:

- Explain what a ratio is in your own words.
- What things must you pay attention to when writing a ratio?
- What are some words and phrases that are used to write a ratio?

1.4 A Collection of Animals

Cool Down: 5 minutes

Addressing

- 6.RP.A.1

Student Task Statement

Here is a collection of dogs, mice, and cats:

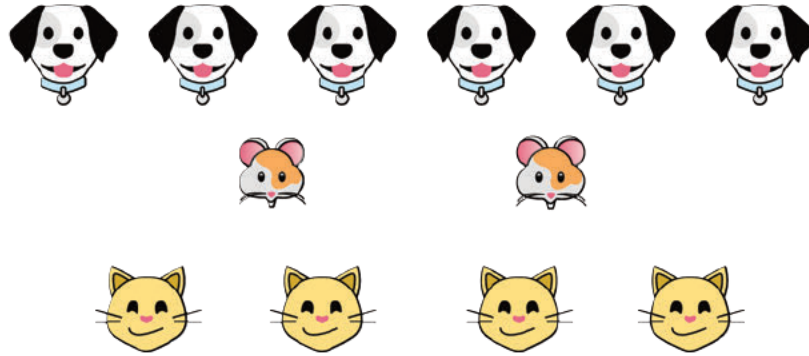

Write *two* sentences that describe a ratio of types of animals in this collection.

Student Response

Answers vary. Sample responses:

- The ratio of dogs to cats is 6 : 4.
- There are 3 dogs for every 2 cats.
- There is 1 mouse for every 2 cats.
- The ratio of cats to mice is 4 : 2.

Student Lesson Summary

A **ratio** is an association between two or more quantities. There are many ways to describe a situation in terms of ratios. For example, look at this collection:

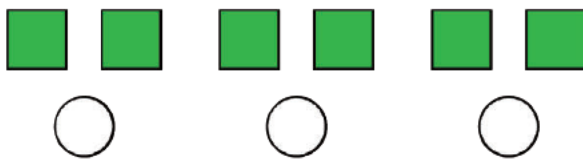

Here are some correct ways to describe the collection:

- The ratio of squares to circles is 6 : 3.
- The ratio of circles to squares is 3 to 6.

Notice that the shapes can be arranged in equal groups, which allow us to describe the shapes using other numbers.

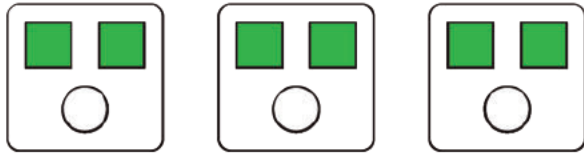

- There are 2 squares for every 1 circle.
- There is 1 circle for every 2 squares.

Glossary

- ratio

Lesson 1 Practice Problems

Problem 1

Statement

In a fruit basket there are 9 bananas, 4 apples, and 3 plums.

- The ratio of bananas to apples is _____ : _____.
- The ratio of plums to apples is _____ to _____.
- For every _____ apples, there are _____ plums.
- For every 3 bananas there is one _____.

Solution

- 9, 4
- 3, 4
- 4, 3
- plum

Problem 2

Statement

Complete the sentences to describe this picture.

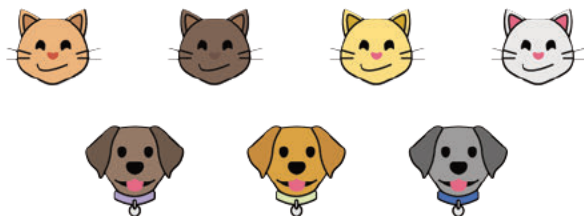

- The ratio of dogs to cats is _____.
- For every _____ dogs, there are _____ cats.

Solution

- a. 3 to 4
- b. 3, 4

Problem 3

Statement

Write two different sentences that use ratios to describe the number of eyes and legs in this picture.

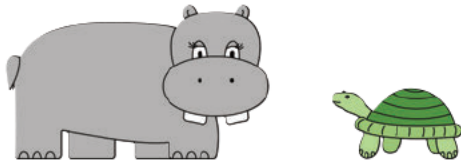

Solution

Answers vary. Sample responses:

- The ratio of legs to eyes is 8 to 4.
- The ratio of eyes to legs is 4 : 8.
- There are 2 legs for every eye.
- There are 4 legs for every 2 eyes.

Problem 4

Statement

Choose an appropriate unit of measurement for each quantity.

- a. area of a rectangle ◦ cm
- b. volume of a prism ◦ cm^3
- c. side of a square ◦ cm^2
- d. area of a square
- e. volume of a cube

Solution

- a. cm^2

- b. cm^3
- c. cm
- d. cm^2
- e. cm^3

(From Unit 1, Lesson 17.)

Problem 5

Statement

Find the volume and surface area of each prism.

- a. Prism A: 3 cm by 3 cm by 3 cm



- b. Prism B: 5 cm by 5 cm by 1 cm



- c. Compare the volumes of the prisms and then their surface areas. Does the prism with the greater volume also have the greater surface area?

Solution

- a. Volume: 27 cubic inches, surface area: 54 square inches
- b. Volume: 25 cubic inches, surface area: 70 square inches
- c. Prism A has a greater volume, but Prism B has a greater surface area.

(From Unit 1, Lesson 16.)

Problem 6

Statement

Which figure is a triangular prism? Select **all** that apply.

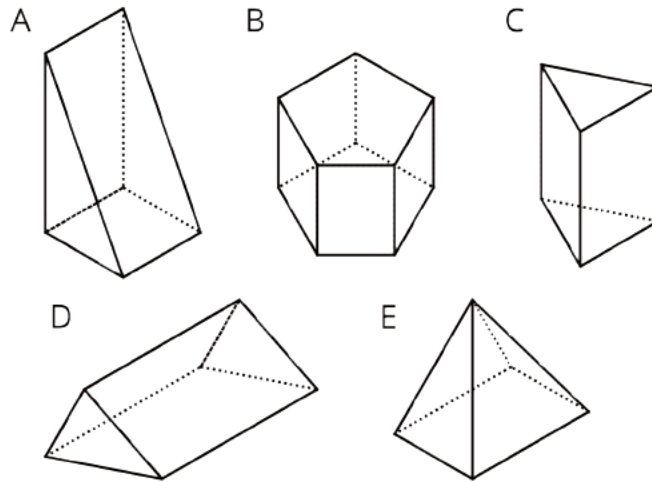

- A. A
- B. B
- C. C
- D. D
- E. E

Solution

["A", "C", "D"]

(From Unit 1, Lesson 13.)

Lesson 2: Representing Ratios with Diagrams

Goals

- Coordinate discrete diagrams and multiple written sentences describing the same ratios.
- Draw and label discrete diagrams to represent situations involving ratios.
- Practice reading and writing sentences describing ratios, e.g., “The ratio of these to those is $a : b$. The ratio of these to those is a to b . For every a of these, there are b of those.”

Learning Targets

- I can draw a diagram that represents a ratio and explain what the diagram means.
- I include labels when I draw a diagram representing a ratio, so that the meaning of the diagram is clear.

Lesson Narrative

Students used physical objects to learn about ratios in the previous lesson. Here they use diagrams to represent situations involving ratios and continue to develop ratio language. The use of diagrams to represent ratios involves some care so that students can make strategic choices about the tools they use to solve problems. Both the visual and verbal descriptions of ratios demand careful interpretation and use of language (MP6).

Students should see diagrams as a useful and efficient ways to represent ratios. There is not really a right or wrong way to draw a diagram; what is important is that it represents the mathematics and makes sense to the student, and the student can explain how the diagram is being used. However, a goal of this lesson is to help students draw useful diagrams efficiently.

For example, here is a diagram to show 6 cups of juice and 3 cups of soda water in a recipe.

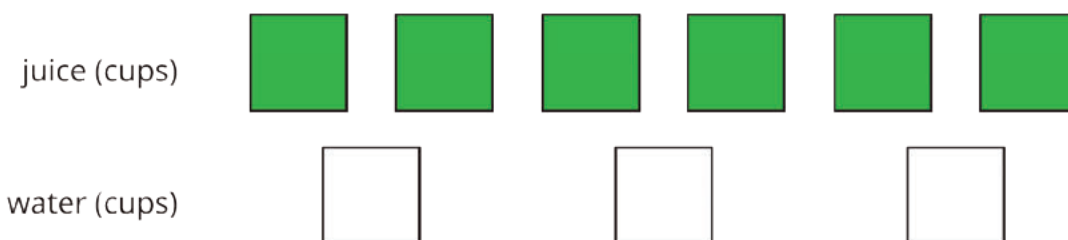

When students are asked to draw diagrams, they often include unnecessary details such as making each cup look like an actual cup, which makes the diagrams inefficient to use for solving problems. Examples of very simple diagrams help guide students toward more abstract representations while still relying on visual or spatial cues to support reasoning.

Diagrams can also help students see associations between quantities in different ways. For example, we can see there are 2 cups of juice for 1 cup of soda water by grouping the items as shown below.

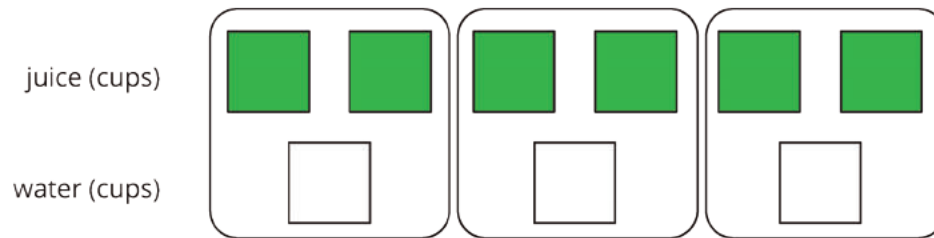

While students may say “for every 2 cups of juice there is 1 cup of soda,” note that for now, we will not suggest writing the association as $2 : 1$. Equivalent ratios will be carefully developed in upcoming lessons. Diagrams like the one above are referred to as “discrete diagrams” in these materials, but students do not need to know this term. In student-facing materials they are simply called “diagrams.”

The discrete diagrams in this lesson are meant to reflect the parallel structure of double number lines that students will learn later in the unit. But for now, students do not need to draw them this way as long as they can explain their diagrams and interpret discrete diagrams like the ones shown in the lesson.

Alignments

Building On

- 5.NF.B.3: Interpret a fraction as division of the numerator by the denominator ($a/b = a \div b$). Solve word problems involving division of whole numbers leading to answers in the form of fractions or mixed numbers, e.g., by using visual fraction models or equations to represent the problem. For example, interpret $3/4$ as the result of dividing 3 by 4, noting that $3/4$ multiplied by 4 equals 3, and that when 3 wholes are shared equally among 4 people each person has a share of size $3/4$. If 9 people want to share a 50-pound sack of rice equally by weight, how many pounds of rice should each person get? Between what two whole numbers does your answer lie?

Addressing

- 6.RP.A.1: Understand the concept of a ratio and use ratio language to describe a ratio relationship between two quantities. For example, “The ratio of wings to beaks in the bird house at the zoo was $2 : 1$, because for every 2 wings there was 1 beak.” “For every vote candidate A received, candidate C received nearly three votes.”

Instructional Routines

- Anticipate, Monitor, Select, Sequence, Connect
- Group Presentations
- MLR2: Collect and Display
- MLR8: Discussion Supports
- Number Talk
- Take Turns

Required Materials

Colored pencils

Copies of blackline master

Pre-printed slips, cut from copies of the blackline master

Tools for creating a visual display

Any way for students to create work that can be easily displayed to the class. Examples: chart paper and markers, whiteboard space and markers, shared online drawing tool, access to a document camera.

Required Preparation

For the Card Sort: Spaghetti Sauce activity, make 1 copy of the blackline master for each group of 2 students, plus a few extras. The blackline master shows the correct matches. Keep the extra copies whole to serve as answer keys. Cut up the rest of the slips for students to use, and throw away the cut slips that say “The above diagram also matches this sentence.” It may be helpful to copy each group’s slips on a different color of paper, so that misplaced slips can quickly be put back.

Student Learning Goals

Let’s use diagrams to represent ratios.

2.1 Number Talk: Dividing by 4 and Multiplying by $\frac{1}{4}$

Warm Up: 10 minutes

This number talk helps students recall that dividing by a number is the same as multiplying by its reciprocal. Four problems are given, however, they do not all require the same amount of time. Consider spending 6 minutes on the first three questions and 4 on the fourth question.

In grade 4, students multiplied a fraction by a whole number, using their understanding of multiplication as groups of a number as the basis for their reasoning. In grade 5, students multiply fractions by whole numbers, reasoning in terms of taking a part of a part, either by using division or partitioning a whole. In both grade levels, the context of the problem played a significant role in how students reasoned and notated the problem and solution. Two important ideas that follow from this work and that will be relevant to future work should be emphasized during discussions:

- Dividing by a number is the same as multiplying by its reciprocal.
- We can multiply numbers in any order if it makes it easier to find the answer.

Building On

- 5.NF.B.3

Instructional Routines

- MLR8: Discussion Supports
- Number Talk

Launch

Display one problem at a time. Give students 1 minute of quiet think time per problem and ask them to give a signal when they have an answer and a strategy. Allow students to share their answers with a partner and note any discrepancies. Pause after the third question and ask, “What do you notice about the first three questions? Do you notice the same thing if we divide 5 by 4? Why?”

Support for Students with Disabilities

Representation: Internalize Comprehension. To support working memory, provide students with sticky notes or mini whiteboards.

Supports accessibility for: Memory; Organization

Student Task Statement

Find the value of each expression mentally.

$$24 \div 4$$

$$\frac{1}{4} \cdot 24$$

$$24 \cdot \frac{1}{4}$$

$$5 \div 4$$

Student Response

- $24 \div 4 = 6$; Possible strategies: Divide 24 into 4 equal groups or know that $4 \cdot 6 = 24$.
- $\frac{1}{4} \cdot 24 = 6$; Possible strategies: Divide 24 into 4 equal groups or know that $4 \cdot 6 = 24$.
- $24 \cdot \frac{1}{4} = 6$; Possible strategies: Divide 24 into 4 equal groups or know that $4 \cdot 6 = 24$ or Commutative Property from the second question.
- $5 \div 4 = \frac{5}{4}$ or equivalent; Possible strategies: Distributive Property
 $(4 + 1) \div 4 = (4 \div 4) + (1 \div 4)$ or know that $5 \cdot \frac{1}{4} = \frac{5}{4}$.

Activity Synthesis

Ask students to share what they noticed about the first three problems. Record student explanations that connect dividing by a number with multiplying by its reciprocal. Revisit the meaning of “reciprocal” when the term comes up (or bring it up if it's not mentioned by students). Help students recall that the product of a number and its reciprocal is 1.

Discuss how students could use their observations on the first three questions to divide 5 by 4, and then any two whole numbers.

Support for English Language Learners

Speaking: MLR8 Discussion Supports.: Display sentence frames to support students when they explain their strategy. For example, "First, I ____ because . . ." or "I noticed ____ so I" Some students may benefit from the opportunity to rehearse what they will say with a partner before they share with the whole class.

Design Principle(s): Optimize output (for explanation)

2.2 A Collection of Snap Cubes

Optional: 10 minutes

Here students read ratio information from a picture and represent it as a diagram. The activity serves two purposes: to reinforce ratio language introduced in the previous lesson, and to better understand the meaning of the term "diagram."

As students work, check that they use ratios in their sentences and draw appropriate diagrams. Examples of sentences with ratios (from the previous lesson) should be posted in the room. Draw students' attention to these existing examples as needed.

Look for students who write ratios involving the same values, e.g., "the ratio of blue to white is 1 to 1," or make note if no one does so. If all examples of ratios students have come across so far involve pairs or sets with different numbers for their values, students may mistakenly conclude that quantities that have the same values cannot be expressed as a ratio.

For non-sighted or color-blind students, this activity can be adapted by giving them blocks of different shapes.



Addressing

- 6.RP.A.1

Instructional Routines

- MLR8: Discussion Supports

Launch

Orient students to the picture (if you have real cubes, use them). Review the meaning of “diagram.” For example, to represent two green snap cubes, you might draw two green squares on the board, or two squares labeled “G” if colors are not available.



Arrange students in groups of 2. Provide access to colored pencils.

Support for Students with Disabilities

Representation: Develop Language and Symbols. Use virtual or concrete manipulatives to connect symbols to concrete objects or values. Provide students with snap cubes or blocks or different shapes.

Supports accessibility for: Conceptual processing

Anticipated Misconceptions

Students might not draw discrete diagrams at first. They might be inclined to draw more detailed drawings. Emphasize that a diagram represents the number and type of objects, and does not need to represent details about the shapes of the snap cubes.

Student Task Statement

Here is a collection of snap cubes.



1. Choose two of the colors in the image, and draw a diagram showing the number of snap cubes for these two colors.
2. Trade papers with a partner. On their paper, write a sentence to describe a ratio shown in their diagram. Your partner will do the same for your diagram.
3. Return your partner's paper. Read the sentence written on your paper. If you disagree, explain your thinking.

Student Response

Answers vary. Sample response:

- The ratio of green cubes to black cubes is 2 : 1.
- The ratio of black cubes to green cubes is 1 to 2.
- For every two green cubes, there is one black cube.

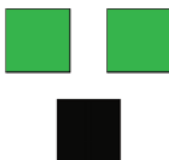

Activity Synthesis

Invite one or two pairs of students to share their sentences. Press for details as they explain, asking them to clarify, elaborate, or give examples. Revoice student ideas to demonstrate mathematical language. Discuss whether or not students were able to interpret one another's drawings accurately. If not, what may have led to confusion?

If no one wrote ratios in which all numbers are the same (e.g., 1 to 1, or 3 : 3), ask if the following sentence is acceptable and why or why not: "The ratio of green cubes to blue cubes is 2 to 2." If

students suspect that ratios are only used to associate quantities with different values, clarify that this is not the case.

Support for English Language Learners

Representing: MLR8 (Discussion Supports). Clarify mathematical use of the term “to” (as in 1 to 1 or 2 to 2) highlighting its use to compare the quantities. Listen for any misunderstanding about the use of the word “to”.

Design Principle: Maximize meta-awareness

2.3 Blue Paint and Art Paste

10 minutes

In this activity, students continue to draw connections between a diagram and the ratios it represents. Students work in pairs to discuss different ways to use ratio language to describe discrete diagrams. They first identify statements that would correctly describe a given diagram. Then, they create both a diagram and corresponding statements to represent a new situation involving ratio.

As students work, monitor for different ways in which students draw and discuss diagrams of the paste recipe. Identify a few pairs who draw different diagrams and use ratio language differently to share later. A few things to anticipate:

- Some students may draw very literal drawings of cups and pints. Encourage them to use simpler representations.
- Students may choose to draw letters (X's) or other symbols or marks instead of squares and rectangles.
- Students may use equivalent ratios to describe a situation, even though these have not been explicitly taught (e.g., they may say the ratio of cups of flour to pints of water is 4 : 1 instead of 8 : 2). Though this is correct, be careful here. We have previously regrouped objects and might say, for example, that with a ratio 8 : 2, “for every 4 cups of flour there is 1 cup of water,” but we have not asserted that this ratio can be written as 4 : 1 yet. The idea of equivalent ratios is sophisticated and will be developed over the next several lessons.
- Correct descriptions may include fractions (e.g., for every tablespoon of blue paint, there is $\frac{1}{3}$ cup of white paint). Although students are not expected to work with fractions in this lesson, responses involving fractions are fine.

Addressing

- 6.RP.A.1

Instructional Routines

- Anticipate, Monitor, Select, Sequence, Connect
- Group Presentations
- MLR2: Collect and Display

Launch

Arrange students in groups of 2. Provide them with the tools needed for creating a large visual display for the second part of the task. Ensure students understand they are supposed to select more than one statement for the first question. Consider having students take turns reading each statement and deciding whether they think it describes the situation or not.

Support for English Language Learners

Speaking, Writing: MLR2 Collect and Display. Circulate and listen to student talk during partner or group work, and display publicly common or important words and phrases (e.g., for every, the ratio of, for each) students are using. Refer back to this list, and ask students to clarify their meaning, explain how they are useful, and to reflect on which words and phrases help to communicate ideas more precisely. This will provide access to important language for students to use as they are needed.

Design Principle(s): Support sense-making

Anticipated Misconceptions

Some students may think all of the statements about the paint mixture are accurate descriptions. If so, suggest that there are two false statements. Have students discuss the statements again in determining which two are false.

Student Task Statement

Elena mixed 2 cups of white paint with 6 tablespoons of blue paint.

Here is a diagram that represents this situation.

white paint (cups)



blue paint (tablespoons)



1. Discuss each statement, and circle **all** those that correctly describe this situation. Make sure that both you and your partner agree with each circled answer.
 - a. The ratio of cups of white paint to tablespoons of blue paint is 2 : 6.
 - b. For every cup of white paint, there are 2 tablespoons of blue paint.

- c. There is 1 cup of white paint for every 3 tablespoons of blue paint.
 - d. There are 3 tablespoons of blue paint for every cup of white paint.
 - e. For each tablespoon of blue paint, there are 3 cups of white paint.
 - f. For every 6 tablespoons of blue paint, there are 2 cups of white paint.
 - g. The ratio of tablespoons of blue paint to cups of white paint is 6 to 2.
2. Jada mixed 8 cups of flour with 2 pints of water to make paste for an art project.
- a. Draw a diagram that represents the situation.
 - b. Write at least two sentences describing the ratio of flour and water.

Student Response

1. The following statements describe the paint mixture:
- A. The ratio of cups of white paint to tablespoons of blue paint is 2 : 6.
 - C. There is 1 cup of white paint for every 3 tablespoons of blue paint.
 - D. There are 3 tablespoons of blue paint for every cup of white paint.
 - F. For every 6 tablespoons of blue paint, there are 2 cups of white paint.
 - G. The ratio of tablespoons of blue paint to cups of white paint is 6 to 2.

The following statements do *not* describe the paint mixture:

- B. For every cup of white paint there are 2 tablespoons of blue paint.
- E. For each tablespoon of blue paint there are 3 cups of white paint.

2. Answers vary. Sample responses:
- The ratio of cups of flour to pints of water is 8 : 2.
 - The ratio of pints of water to cups of flour is 2 to 8.
 - For each pint of water, there are 4 cups of flour.
 - For every 8 cups of flour, there are 2 pints of water.
 - For every 4 cups of flour, there is 1 pint of water.
 - There are 2 pints of water for every 8 cups of flour.

Activity Synthesis

Select students to share their paste diagrams and sentences with the class. Sequence the diagrams from most elaborate to most simple. Connect the many ways in which the paste can be represented and described. Compare more detailed pictures with a discrete diagram; point out how the discrete diagram is a more efficient way of showing the paste recipe.

2.4 Card Sort: Spaghetti Sauce

15 minutes

Writing and using ratio language requires attention to detail. This task further develops students' ability to describe ratio situations precisely by attending carefully to the quantities, their units, and their order in the ratio.

Students work in pairs to match ratios of sauce ingredients to discrete diagrams and to explain reasoning (MP3).

Addressing

- 6.RP.A.1

Instructional Routines

- MLR8: Discussion Supports
- Take Turns

Launch

Arrange students in groups of 2. Place two copies of uncut blackline masters in envelopes to serve as answer keys.

Demonstrate how to set up and play the matching game. Choose a student to be your partner. Discuss what all the symbols mean. Mix up the cards and place them face-up. Point out that the cards contain either diagrams or sentences. Select one of each style of card and then explain to your partner why you think the cards do or do not match. Demonstrate productive ways to agree or disagree, e.g., by explaining your mathematical thinking, asking clarifying questions, etc.

Give each group cut-up cards for matching. Tell students to check their matches after they complete the activity using the answer keys.

Support for Students with Disabilities

Action and Expression: Develop Expression and Communication. To help get students started, display sentence frames such as, "_____ and _____ are a match because"

Supports accessibility for: Language; Organization

Anticipated Misconceptions

If students disagree about a match, encourage them to figure out the correct answer through discussion and use of the answer key. Make sure that when students use the answer key, they discuss any errors rather than just make changes.

Students may think the shapes in the diagram need to be drawn in the same order the ingredients appear in the description. This is not the case. You could turn a diagram card upside down and it

would still represent the same situation. The diagram just shows ingredients that get mixed together in a pot. It *is* the case, however, that within the description, the order of the words in the sentence must correspond with the terms within the ratio.

Student Task Statement

Your teacher will give you cards describing different recipes for spaghetti sauce. In the diagrams:

- a circle represents a cup of tomato sauce
- a square represents a tablespoon of oil
- a triangle represents a teaspoon of oregano



1. Take turns with your partner to match a sentence with a diagram.
 - a. For each match that you find, explain to your partner how you know it's a match.
 - b. For each match that your partner finds, listen carefully to their explanation. If you disagree, discuss your thinking and work to reach an agreement.
2. After you and your partner have agreed on all of the matches, check your answers with the answer key. If there are any errors, discuss why and revise your matches.
3. There were two diagrams that each matched with two different sentences. Which were they?
 - Diagram _____ matched with both sentences _____ and _____.
 - Diagram _____ matched with both sentences _____ and _____.
4. Select one of the other diagrams and invent another sentence that could describe the ratio shown in the diagram.

Student Response

1.
 - Diagram A matches with sentence 4.
 - Diagram B matches with sentences 2 and 8.
 - Diagram C matches with sentence 1.
 - Diagram D matches with sentence 5.
 - Diagram E matches with sentences 3 and 7.
 - Diagram F matches with sentence 6.
2. No answer necessary.
3.
 - a. Diagram B matches with sentences 2 and 8.
 - b. Diagram E matches with sentences 3 and 7.

4. Answers vary. Sample responses:

- For diagram A, the ratio of cups of tomato sauce to tablespoons of oil is 3 : 1.
- For diagram D, the ratio of tablespoons of oil to cups of tomato sauce is 2 to 5.

Are You Ready for More?

Create a diagram that represents any of the ratios in a recipe of your choice. Is it possible to include more than 2 ingredients in your diagram?

Student Response

Answers vary.

Activity Synthesis

Once all groups have completed the matching, discuss the following:

- Which matches were tricky? Explain why.
- Did any pairs need to make adjustments in their matches? What might have caused an error? What adjustments were made?
- What if you were making this tasty sauce and got the ratios wrong? What would happen?

Support for English Language Learners

Speaking: MLR8 Discussion Supports. To demonstrate mathematical language and to help students with communicating their reasoning clearer, revoice students' ideas and press for details in explanations. Request that students challenge an idea, elaborate on an idea. For example, if a student says that they matched D with 5 ask, "What did you see in Diagram D that matched with the words of Sentence 5?"

Design Principle(s): Optimize output (for explanation)

Lesson Synthesis

This lesson used diagrams to represent ratios. These diagrams omit details that are not necessary for understanding and solving the problem at hand. Discuss:

- What are some good things to remember when you draw a diagram of a ratio? (You only need necessary information. You could include shapes, color-coded boxes, or initials to represent each object within the set. It is helpful to organize the types of items in rows, and to arrange smaller groups so they are easier to see.)
- How can a diagram help you make sense of a situation involving a ratio? (It is easier to write correct statements about them. Also, you can see how the objects can be grouped.)

2.5 Paws, Ears, and Tails

Cool Down: 5 minutes

Addressing

- 6.RP.A.1

Anticipated Misconceptions

In the second question, students may not realize that the order of the words in the sentence must correspond with the terms within the ratio. Ears : paws : tails must correspond with 6 : 12 : 3. In the fourth question, students may not write the sentence for every *one* ear. If this is the case, prompt them to draw a circle around each set of two paws and one ear to help them see this relationship.

Student Task Statement

There are 3 cats in a room and no other creatures. Each cat has 2 ears, 4 paws, and 1 tail.

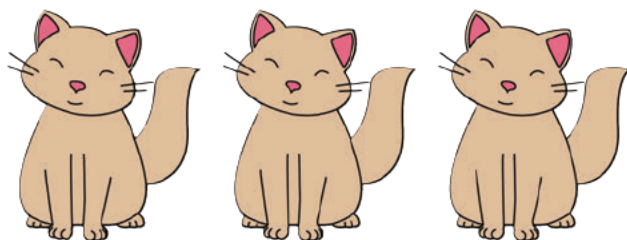

1. Draw a diagram that shows an association between numbers of ears, paws, and tails in the room.
2. Complete each statement:
 - a. The ratio of _____ to _____ to _____ is _____ : _____ : _____.
 - b. There are _____ paws for every tail.
 - c. There are _____ paws for every ear.

Student Response

1. Answers vary. Sample response:

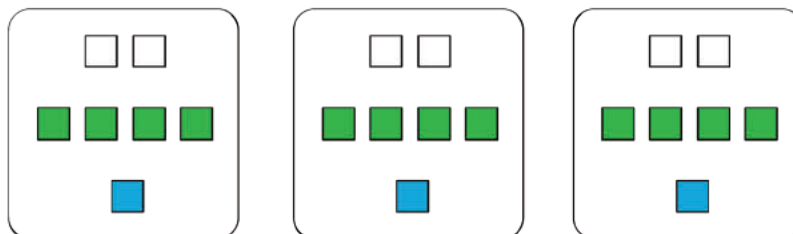

2.
 - a. The ratio of ears to paws to tails is 6 : 12 : 3.
 - b. There are 4 paws for every tail.

c. There are 4 paws for every 2 ears. This means that there are 2 paws for every ear.

Student Lesson Summary

Ratios can be represented using diagrams. The diagrams do not need to include realistic details. For example, a recipe for lemonade says, "Mix 2 scoops of lemonade powder with 6 cups of water."

Instead of this:

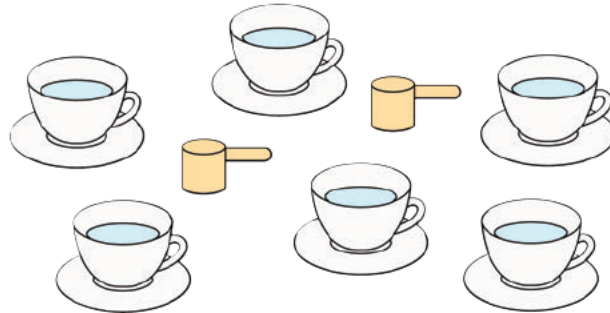

We can draw something like this:

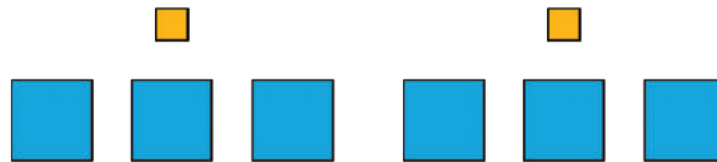

This diagram shows that the ratio of cups of water to scoops of lemonade powder is 6 to 2. We can also see that for every scoop of lemonade powder, there are 3 cups of water.

Lesson 2 Practice Problems

Problem 1

Statement

Here is a diagram that describes the cups of green and white paint in a mixture.

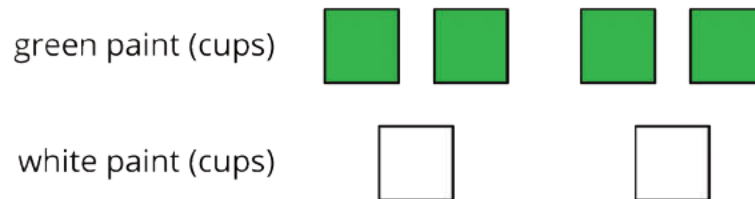

Select **all** the statements that correctly describe this diagram

- A. The ratio of cups of white paint to cups of green paint is 2 to 4.
- B. For every cup of green paint, there are two cups of white paint.
- C. The ratio of cups of green paint to cups of white paint is 4 : 2.
- D. For every cup of white paint, there are two cups of green paint.
- E. The ratio of cups of green paint to cups of white paint is 2 : 4.

Solution

["A", "C", "D"]

Problem 2

Statement

To make a snack mix, combine 2 cups of raisins with 4 cups of pretzels and 6 cups of almonds.

- a. Create a diagram to represent the quantities of each ingredient in this recipe.
- b. Use your diagram to complete each sentence.
 - The ratio of _____ to _____ to _____ is _____ : _____ : _____.
 - There are _____ cups of pretzels for every cup of raisins.
 - There are _____ cups of almonds for every cup of raisins.

Solution

- a. Answers vary. Sample response:

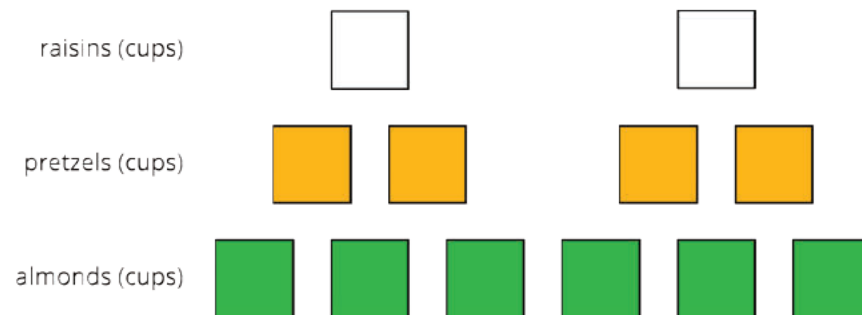

- b. Statements:

- Answers vary. Sample response: cups of raisins, cups of pretzels, cups of almonds, 2, 4, 6
- 2
- 3

Problem 3

Statement

- A square is 3 inches by 3 inches. What is its area?
- A square has a side length of 5 feet. What is its area?
- The area of a square is 36 square centimeters. What is the length of each side of the square?

Solution

- 9 square inches ($3 \cdot 3 = 9$)
- 25 square feet ($5 \cdot 5 = 25$)
- 6 centimeters ($6 \cdot 6 = 36$)

(From Unit 1, Lesson 17.)

Problem 4

Statement

Find the area of this quadrilateral. Explain or show your strategy.

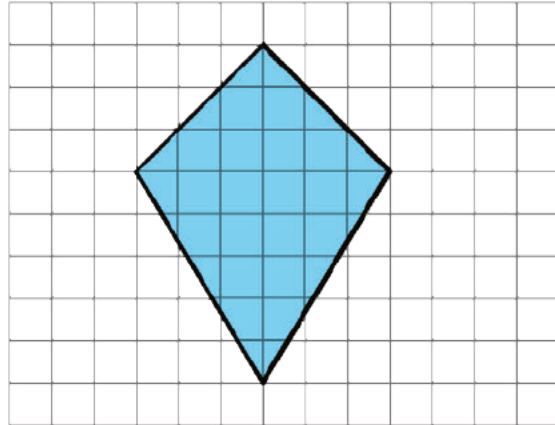

Solution

24 square units. Possible strategy: Decompose the quadrilateral into two triangles with a horizontal cut. The top triangle has a base of 6 units and a height of 3 units. Its area is 9 square units, as $(6 \cdot 3) \div 2 = 9$. The bottom triangle has a base of 6 units and a height of 5 units. Its area is 15 square units, as $(6 \cdot 5) \div 2 = 15$. $9 + 15 = 24$. The area of the quadrilateral is then 24 square units.

(From Unit 1, Lesson 11.)

Problem 5

Statement

Complete each equation with a number that makes it true.

a. $\frac{1}{8} \cdot 8 = \underline{\hspace{2cm}}$

a. $\frac{1}{8} \cdot 7 = \underline{\hspace{2cm}}$

b. $\frac{3}{8} \cdot 8 = \underline{\hspace{2cm}}$

b. $\frac{3}{8} \cdot 7 = \underline{\hspace{2cm}}$

Solution

- a. 1 (or equivalent)
- b. 3 (or equivalent)
- c. $\frac{7}{8}$ (or equivalent)
- d. $\frac{21}{8}$ (or equivalent, $2\frac{5}{8}$ for example)

(From Unit 2, Lesson 1.)

Section: Equivalent Ratios

Lesson 3: Recipes

Goals

- Draw and label a discrete diagram with circled groups to represent multiple batches of a recipe.
- Explain equivalent ratios (orally and in writing) in terms of different sized batches of the same recipe having the same taste.
- Understand that doubling or tripling a recipe involves multiplying the amount of each ingredient by the same number, yielding something that tastes the same.

Learning Targets

- I can explain the meaning of equivalent ratios using a recipe as an example.
- I can use a diagram to represent a recipe, a double batch, and a triple batch of a recipe.
- I know what it means to double or triple a recipe.

Lesson Narrative

This is the first of two lessons that develop the idea of **equivalent ratios** through physical experiences. A key understanding is that if we scale a recipe up (or down) to make multiple batches (or a fraction of a batch), the result will still be “the same” in some meaningful way. Students see this idea in two contexts, taste and color:

- In this lesson, a mixture containing two batches of a recipe *tastes the same* as a mixture containing one batch. For example, 2 cups of water mixed thoroughly with 8 teaspoons of powdered drink mix tastes the same as 1 cup of water mixed with 4 teaspoons of powdered drink mix.
- In the next lesson, a mixture containing two batches of a recipe for colored water will produce the *same shade* of the color as a mixture containing one batch. For example, 10 ml of blue mixed with 30 ml of yellow produces the same shade of green as 5 ml of blue mixed with 15 ml of yellow.

The fact that two equivalent ratios yield the same taste or produce the same color is a physical manifestation of the equivalence of the ratios.

Students see that scaling a recipe up (or down) requires multiplying the amount of each ingredient by the same factor, e.g., doubling a recipe means doubling the amount of each ingredient (MP7). They also gain more experience using a discrete diagram as a tool to represent a situation.

Alignments

Addressing

- 6.RP.A.1: Understand the concept of a ratio and use ratio language to describe a ratio relationship between two quantities. For example, “The ratio of wings to beaks in the bird house at the zoo was 2 : 1, because for every 2 wings there was 1 beak.” “For every vote candidate A received, candidate C received nearly three votes.”

Instructional Routines

- MLR8: Discussion Supports
- Think Pair Share

Required Materials

Drink mix

A powder that is mixed with water to create a fruit-flavored or chocolate-flavored drink. Using a sugar-free drink mix is recommended, but *not* a mix that calls for adding a separate sweetener when mixing up the drink.

Empty containers

Markers

Paper cups

Teaspoon

Water

Required Preparation

Create two separate drink mixtures. Container A has one cup of water and one teaspoon of powdered drink mix. Container B has one cup of water and four teaspoons of powdered drink mix. You might have to stir the mixtures vigorously for a minute or more to ensure all the powder dissolves.

Get 6 small paper cups. Do not mark the cups. Put a small amount of mixture A in three of the cups and a small amount of mixture B in the other three cups. (Keep track of which is which, as you will give each of three volunteers one of each cup.) Discard the rest of the mixtures for now. (You will do a dramatic performance creating each mixture during class.)

During class, you will need three empty mixing containers with at least a 2-cup capacity each. One marked A, one marked B, and one marked C. You will also need a supply of water, a supply of drink mix, a measuring cup, and a teaspoon.

Student Learning Goals

Let’s explore how ratios affect the way a recipe tastes.

3.1 Flower Pattern

Warm Up: 5 minutes

The purpose of this warm-up is to quickly remind students of different ways to write ratios. They also have an opportunity to multiply the number of each type of shape by 2 to make two copies of the flower, which previews the process introduced in this lesson for making a double batch of a recipe.

Addressing

- 6.RP.A.1

Instructional Routines

- Think Pair Share

Launch

Arrange students in groups of 2. Ensure students understand there are 6 hexagons, 2 trapezoids, and 9 triangles in the picture, and that their job is to write ratios about the numbers of shapes. Give 2 minutes of quiet work time and then invite students to share their sentences with their partner, followed by whole-class discussion.

Anticipated Misconceptions

Students might get off track by attending to the area each shape covers. Clarify that this task is only concerned with the number of each shape and not the area covered.

Student Task Statement

This flower is made up of yellow hexagons, red trapezoids, and green triangles.

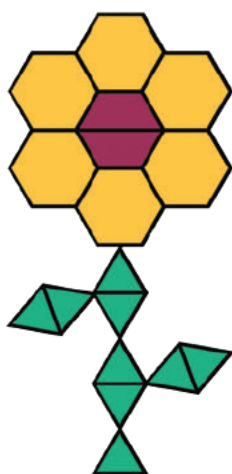

1. Write sentences to describe the ratios of the shapes that make up this pattern.
2. How many of each shape would be in two copies of this flower pattern?

Student Response

1. Answers vary. Sample responses:
 - For every 2 hexagons there are 3 triangles.
 - There are 3 hexagons for every trapezoid.
 - The ratio of trapezoids to triangles is 2 to 9.
 - The ratio of hexagons to trapezoids to triangles is 6 : 2 : 9.
2. There would be 12 yellow hexagons, 4 red trapezoids and 18 green triangles.

Activity Synthesis

Invite a student to share a sentence that describe the ratios of shapes in the picture. Ask if any students described the same relationship a different way. For example, three ways to describe the same ratio are: The ratio of hexagons to trapezoids is $6 : 2$. The ratio of trapezoids to hexagons is 2 to 6. There are 3 hexagons for every trapezoid.

Ask a student to describe why two copies of the picture would have 12 hexagons, 4 trapezoids, and 18 triangles. If no student brings it up, be sure to point out that each number in one copy of the picture can be multiplied by 2 to find the number of each shape in two copies.

3.2 Powdered Drink Mix

15 minutes

In this activity, three student volunteers participate in a taste test of two drink mixtures. Mixture A is made with 1 cup of water and 1 teaspoon of drink mix. Mixture B is made with 1 cup of water and 4 teaspoons of drink mix. The taste testers match diagrams with each mixture and explain their reasoning.

After the taste test, in front of students, recreate mixture A (1 cup water with 1 teaspoon of drink mix) and mixture B (1 cup water with 4 teaspoons of drink mix). Ask students to describe how the diagrams correspond with these mixtures. Then, conduct a demonstration in which 3 teaspoons of drink mix are added to Mixture A and a new diagram is drawn. Once Mixture A and Mixture B both contain one cup of water and 4 teaspoons of drink mix, both mixtures are combined in a third container labeled Mixture C.

As part of their work on the task, students reason that this combined mixture tastes the same as each individual batch. Students then conclude that a mixture containing two batches tastes the same as the mixture that contains just one batch, because mixing two things together that taste the same will produce a mixture that tastes the same. They should also note that each ingredient was doubled in the mixture.

Addressing

- 6.RP.A.1

Instructional Routines

- MLR8: Discussion Supports

Launch

Display the diagram for all to see:

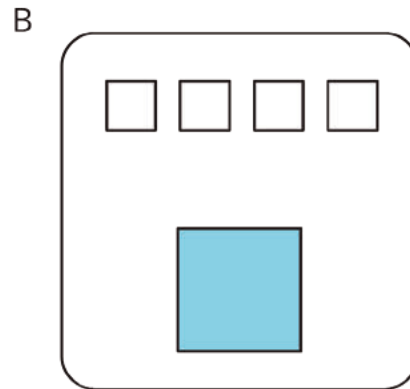
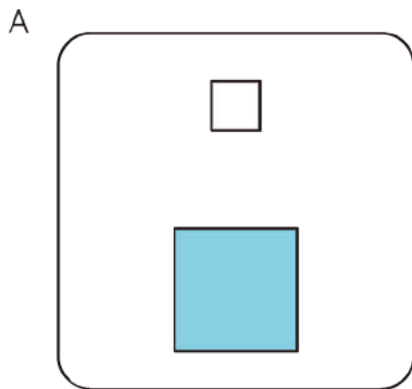

Taste test: Recruit three volunteers for a taste test. Give each volunteer two unmarked cups—one each of a small amount of Mixture A and Mixture B. Explain that their job is to take a tiny sip of each sample, match the diagrams to the samples, and explain their matches.

Demonstration: Conduct a dramatic demonstration of mixing powdered drink mix and water. Start with two empty containers labeled A and B. To Container A, add 1 cup of water and 1 teaspoon of drink mix. To Container B, add 1 cup of water and 4 teaspoons of drink mix. Mix them both thoroughly. The first diagram should still be displayed.

Discuss:

- Which mixture has a stronger flavor? (B has more drink mix in the same quantity of water).
- How can we make Mixture A taste like Mixture B? (Put 3 more teaspoons of drink mix into Container A.)

Add 3 more teaspoons of drink mix to Container A. Display a new diagram to represent the situation:

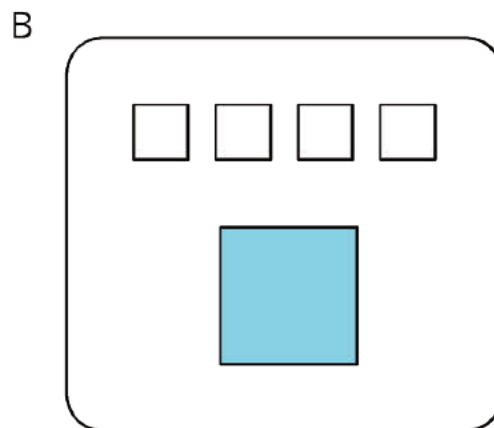
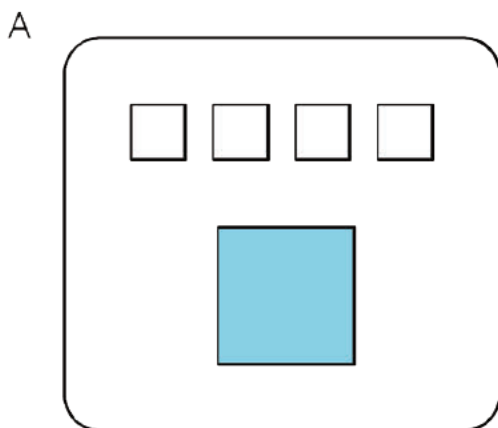

Discuss:

- Describe the ratio of ingredients that is now in Container A. (The ratio of cups of water to teaspoons of drink mix is 1 : 4.)

- Describe the ratio of ingredients that is in Container B. (The ratio of cups of water to teaspoons of drink mix is also 1 to 4.)
- How do you think they compare in taste? (They taste the same. If desired, you can have volunteers verify that they taste the same, but this might not be necessary.)

Pour the contents of both A and B into a larger container labeled C and mix them thoroughly.

Discuss:

- How would the taste of Mixture C compare to the taste of Mixture A and Mixture B? (The new mixture would taste the same as each component mixture.)

Following this demonstration, students individually interpret the drink mixture diagrams. The work in the task will reiterate what happened in the demonstration.

Support for English Language Learners

Conversing: MLR8 Discussion Supports. Use this routine to support whole-class discussion. Ask “What if I add a half cup of water to C?” or “What if I add a teaspoon of drink mix to B?” To help students justify their reasoning, display a sentence frame such as: “Mixtures B and C will taste ___ because”

Design Principle(s): Support sense-making

Anticipated Misconceptions

Students may not initially realize that Mixtures C and B taste the same. You could ask them to imagine ordering a smoothie from a takeout window. Would a small size smoothie taste the same as a size that is double that amount? If you double the amount of each ingredient, the mixture tastes the same.

Student Task Statement

Here are diagrams representing three mixtures of powdered drink mix and water:

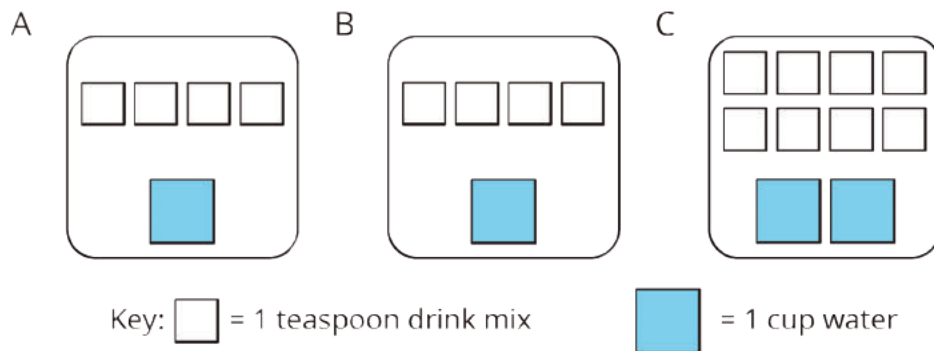

1. How would the taste of Mixture A compare to the taste of Mixture B?

2. Use the diagrams to complete each statement:

- a. Mixture B uses _____ cups of water and _____ teaspoons of drink mix. The ratio of cups of water to teaspoons of drink mix in Mixture B is _____.
- b. Mixture C uses _____ cups of water and _____ teaspoons of drink mix. The ratio of cups of water to teaspoons of drink mix in Mixture C is _____.

3. How would the taste of Mixture B compare to the taste of Mixture C?

Student Response

1. Mixtures A and B will taste the same because they have the same amount of water and drink mix.
2. Mixture B uses 1 cup of water and 4 teaspoons of drink mix. The ratio of cups of water to teaspoons of drink mix in Mixture B is 1 : 4.
3. Mixture C uses 2 cups of water and 8 teaspoons of drink mix. The ratio of cups of water to teaspoons of drink mix in mixture C is 2 : 8.
4. Mixtures B and C will taste the same. This is because Mixture C was made by doubling Mixture B or by mixing A and B together, which taste the same, so the mixture would still taste the same.

Are You Ready for More?

Sports drinks use sodium (better known as salt) to help people replenish electrolytes. Here are the nutrition labels of two sports drinks.

A

Nutrition Facts		
Serving Size 8 fl oz (240 mL)		
Serving Per Container 4		
Amount Per Serving		
Calories 50		
		% Daily Value*
Total Fat	0 g	0%
Sodium	110 mg	5%
Potassium	30 mg	1%
Total Carbohydrate	14 g	5%
Sugars 14 g		
Protein	0 g	
% Daily Value are based on a 2,000 calorie diet.		

B

Nutrition Facts		
Serving Size 12 fl oz (355 mL)		
Serving Per Container about 2.5		
Amount Per Serving		
Calories 80		
		% Daily Value*
Total Fat	0 g	0%
Sodium	150 mg	6%
Potassium	35 mg	1%
Total Carbohydrate	21 g	7%
Sugars 20 g		
Protein	0 g	
% Daily Value are based on a 2,000 calorie diet.		

1. Which of these drinks is saltier? Explain how you know.
2. If you wanted to make sure a sports drink was less salty than both of the ones given, what ratio of sodium to water would you use?

Student Response

1. Drink A. Sample reasoning: Drink A has 110 mg of sodium in an 8 ounce serving. Drink B has 150 mg of sodium in a 12 ounce serving. If we had 24 ounces of each drink, drink A would have 330 mg of sodium and drink B would have 300 mg of sodium. Therefore, drink A is saltier.
2. To be less salty than both drinks, the new drink would have to be less salty than drink B. So, for a 12-ounce serving, you would have to use less than 150 mg of sodium. For example, the ratio of ounces of drink to milligrams of sodium could be 12 to 100.

Activity Synthesis

Mixing 1 cup of water with 4 teaspoons of powdered drink mix makes a mixture that tastes exactly the same as mixing 2 cups of water with 8 teaspoons of powdered drink mix. We say that 1 : 4 and 2 : 8 are **equivalent ratios**. Ask students to discuss what they think “equivalent” means. Some ways they might respond are:

- Mixtures that taste the same use equivalent ratios.
- A double batch of a recipe—doubling each ingredient—is an equivalent ratio to a single batch.

3.3 Batches of Cookies

15 minutes

Students continue to use diagrams to represent the ratio of ingredients in a recipe as well as mixtures that contain multiple batches. They come to understand that a change in the number of batches changes the quantities of the ingredients, but the end product tastes the same. They then use this observation to come up with a working definition for equivalent ratio.

Addressing

- 6.RP.A.1

Launch

Launch the task with a scenario and a question: “Let’s say you are planning to make cookies using your favorite recipe, and you’re going to ‘double the recipe.’ What does it mean to double a recipe?”

There are a few things you want to draw out in this conversation:

- If we double a recipe, we need to double the amount of *every ingredient*. If the recipe calls for 3 eggs, doubling it means using 6 eggs. If the recipe calls for $\frac{1}{3}$ teaspoon of baking soda, we use $\frac{2}{3}$ teaspoon of baking soda, etc.
- We expect to end up with twice as many cookies when we double the recipe as we would when making a single batch.
- However, we expect the cookies from 2 batches of a recipe to taste *exactly the same* as those from a single batch.

Tell students they will now think about making different numbers of batches of a cookie recipe.

Support for Students with Disabilities

Engagement: Develop Effort and Persistence. Encourage and support opportunities for peer interactions. Invite students to talk about their ideas with a partner before writing them down. Display sentence frames to support students when they explain their strategy. For example, "I noticed ____, so I . . .", "In my diagram, ____ represents . . .", and "To find an equivalent ratio, first I ____ because . . ." This will help students produce mathematical language as they make sense of equivalent ratios using diagrams.

Supports accessibility for: Language; Social-emotional skills

Anticipated Misconceptions

For the fourth question, students may not multiply both the amount of flour and the amount of vanilla by the same number. If this happens, refer students to the previous questions in noting that the amount of each ingredient was changed in the same way.

Student Task Statement

A recipe for one batch of cookies calls for 5 cups of flour and 2 teaspoons of vanilla.

1. Draw a diagram that shows the amount of flour and vanilla needed for *two* batches of cookies.
2. How many batches can you make with 15 cups of flour and 6 teaspoons of vanilla? Show the additional batches by adding more ingredients to your diagram.
3. How much flour and vanilla would you need for 5 batches of cookies?
4. Whether the ratio of cups of flour to teaspoons of vanilla is $5 : 2$, $10 : 4$, or $15 : 6$, the recipes would make cookies that taste the same. We call these **equivalent ratios**.
 - a. Find another ratio of cups of flour to teaspoons of vanilla that is equivalent to these ratios.
 - b. How many batches can you make using this new ratio of ingredients?

Student Response

1. Diagrams may look different, but should clearly show two groups of 5 and 2. Here are two ways that students might circle the batches.
If they see each batch individually, they might draw something like this:

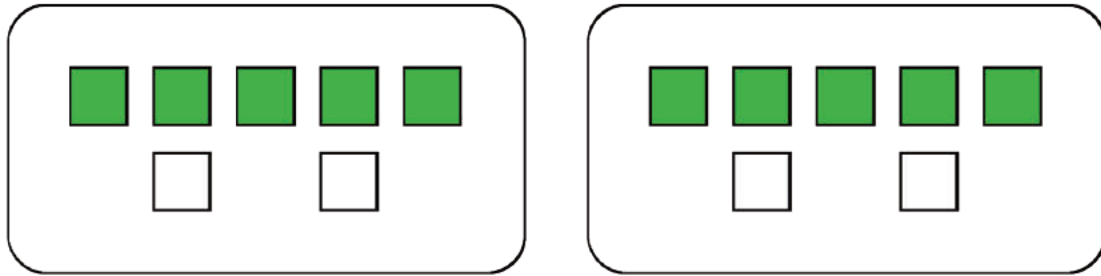

If they think of a “double batch” as a single thing, they might circle it like this:

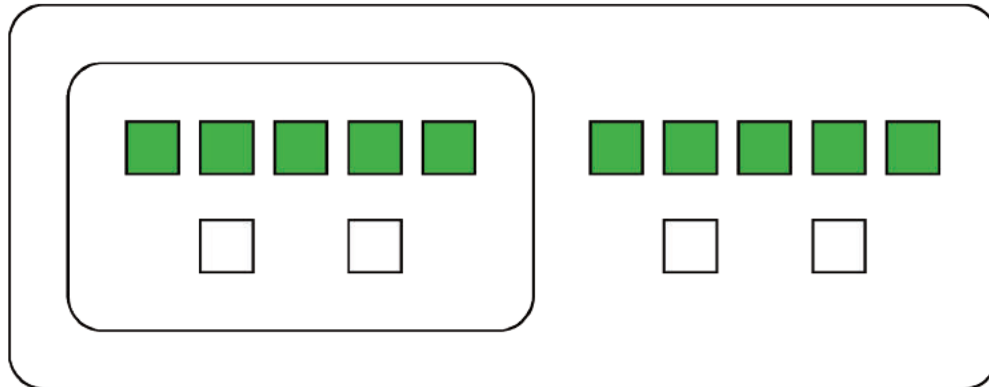

2. You can make 3 batches. Sample diagram:

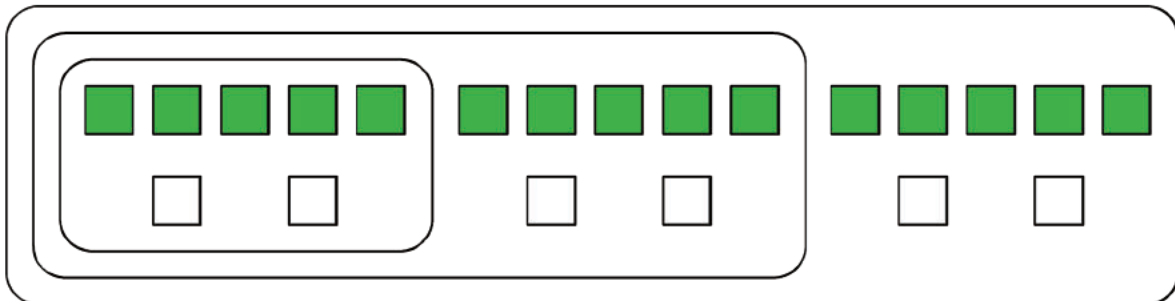

3. You would need 25 cups of flour and 10 teaspoons of vanilla. (The diagram may be expanded to reflect this.)

4. Answers vary. Sample responses:

a. 20 : 8

b. 4 batches

Activity Synthesis

Invite a few students to share their responses and diagrams with the class. A key point to emphasize during discussion is that when we double (or triple) a recipe, we also have to double (or triple) each ingredient. Record a working (but not final) definition for equivalent ratio that can be displayed for at least the next several lessons. Here is an example: “Cups of flour and teaspoons of vanilla in the ratio 5 : 2, 10 : 4, or 15 : 6 are equivalent ratios because they describe different numbers of batches of the same recipe.” Include a diagram in this display.

Lesson Synthesis

The four main ideas you want to draw out to conclude the lesson are:

- To double a recipe, you need to double the amount of each ingredient.
- To scale a recipe generally, you need to multiply each ingredient by the same number.
- Scaling a recipe results in a substance that tastes the same as the original recipe.
- We say that a ratio that represents a recipe is *equivalent* to a ratio that represents multiple batches of the same recipe.

Discuss:

- When doubling a recipe, how does the amount of each individual ingredient change? (Each ingredient is doubled. We call the new ratio of ingredients an **equivalent ratio**.)
- When tripling a recipe, how does the amount of each individual ingredient change? (Each ingredient is tripled. We call the new ratio of ingredients an equivalent ratio.)
- How do different numbers of batches of the same recipe taste? (They taste exactly the same.)

3.4 A Smaller Batch of Bird Food

Cool Down: 5 minutes

Addressing

- 6.RP.A.1

Launch

If necessary, explain that some people like to observe birds. These people might put bird food in a bird feeder outside their homes to attract birds, so they can watch them through a window.

Student Task Statement

Usually when Elena makes bird food, she mixes 9 cups of seeds with 6 tablespoons of maple syrup. However, today she is short on ingredients. Think of a recipe that would yield a smaller batch of bird food but still taste the same. Explain or show your reasoning.

Student Response

Two likely valid answers are:

- 3 cups of seeds and 2 tablespoons of syrup
- 6 cups of seeds and 4 tablespoons of syrup

Explanations and diagrams vary. Here are some possibilities:

3 : 2 represents the cups of seeds to the tablespoons of syrup.

3 : 2 is equivalent to 9 : 6.

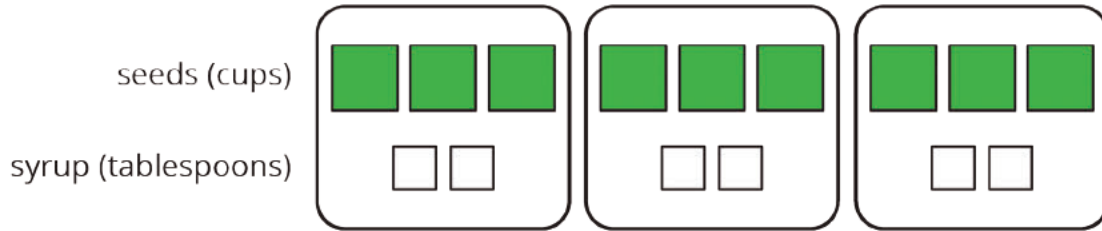

Student Lesson Summary

A recipe for fizzy juice says, “Mix 5 cups of cranberry juice with 2 cups of soda water.”

To double this recipe, we would use 10 cups of cranberry juice with 4 cups of soda water. To triple this recipe, we would use 15 cups of cranberry juice with 6 cups of soda water.

This diagram shows a single batch of the recipe, a double batch, and a triple batch:

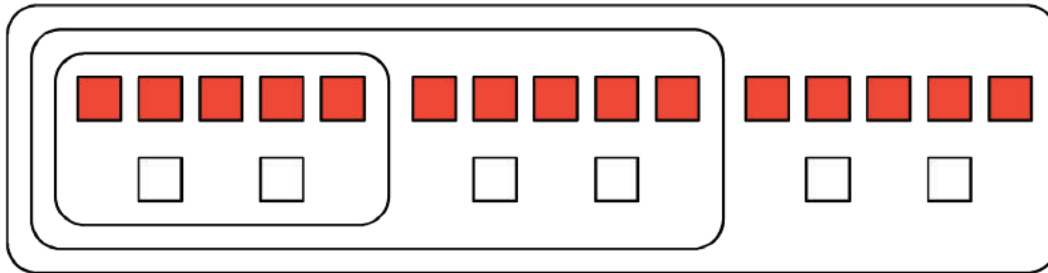

We say that the ratios 5 : 2, 10 : 4, and 15 : 6 are **equivalent**. Even though the amounts of each ingredient within a single, double, or triple batch are not the same, they would make fizzy juice that tastes the same.

Lesson 3 Practice Problems

Problem 1

Statement

A recipe for 1 batch of spice mix says, “Combine 3 teaspoons of mustard seeds, 5 teaspoons of chili powder, and 1 teaspoon of salt.” How many batches are represented by the diagram? Explain or show your reasoning.

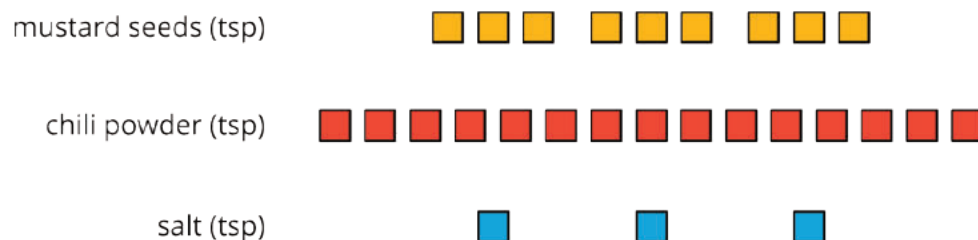

Solution

The diagram represents 3 batches of spice mix. It shows 3 times the amount of each ingredient in the recipe: 9 teaspoons of mustard ($3 \cdot 3$), 15 teaspoons of chili powder ($3 \cdot 5$), and 3 teaspoons of salt ($3 \cdot 1$).

Problem 2

Statement

Priya makes chocolate milk by mixing 2 cups of milk and 5 tablespoons of cocoa powder. Draw a diagram that clearly represents two batches of her chocolate milk.

Solution

Answers vary. Sample response:

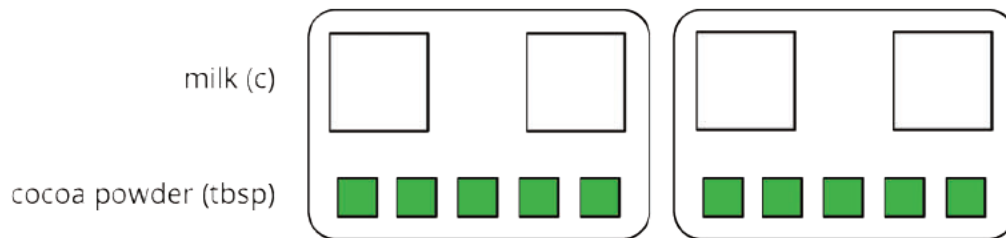

Problem 3

Statement

In a recipe for fizzy grape juice, the ratio of cups of sparkling water to cups of grape juice concentrate is 3 to 1.

- Find two more ratios of cups of sparkling water to cups of juice concentrate that would make a mixture that tastes the same as this recipe.
- Describe another mixture of sparkling water and grape juice that would taste different than this recipe.

Solution

Answers vary. Sample responses:

- 6 to 2
- 6 to 3

Problem 4

Statement

Write the missing number under each tick mark on the number line.

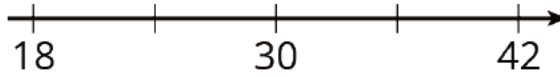

Solution

24, 36 (intervals of 6)

(From Unit 2, Lesson 1.)

Problem 5

Statement

At the kennel, there are 6 dogs for every 5 cats.

- The ratio of dogs to cats is ____ to ____.
- The ratio of cats to dogs is ____ to ____.
- For every ____ dogs there are ____ cats.
- The ratio of cats to dogs is ____ : ____.

Solution

- 6 to 5
- 5 to 6
- 6, 5
- 5 : 6

(From Unit 2, Lesson 1.)

Problem 6

Statement

Elena has 80 unit cubes. What is the volume of the largest cube she can build with them?

Solution

64 cubic units (from a 4 by 4 by 4 cube)

(From Unit 1, Lesson 17.)

Problem 7

Statement

Fill in the blanks to make each equation true.

a. $3 \cdot \frac{1}{3} = \underline{\hspace{2cm}}$

b. $10 \cdot \frac{1}{10} = \underline{\hspace{2cm}}$

c. $19 \cdot \frac{1}{19} = \underline{\hspace{2cm}}$

d. $a \cdot \frac{1}{a} = \underline{\hspace{2cm}}$

(As long as a does not equal 0.)

a. $5 \cdot \underline{\hspace{2cm}} = 1$

b. $17 \cdot \underline{\hspace{2cm}} = 1$

c. $b \cdot \underline{\hspace{2cm}} = 1$

Solution

a. 1 (or equivalent)

b. 1 (or equivalent)

c. 1 (or equivalent)

a. 1 (or equivalent)

b. $\frac{1}{5}$ (or equivalent)

c. $\frac{1}{17}$ (or equivalent)

a. $\frac{1}{b}$ (or equivalent)

(From Unit 2, Lesson 1.)

Lesson 4: Color Mixtures

Goals

- Comprehend and respond (orally and in writing) to questions asking whether two ratios are equivalent, in the context of color mixtures.
- Draw and label a discrete diagram with circled groups to represent multiple batches of a color mixture.
- Explain equivalent ratios (orally and in writing) in terms of the amounts of each color in a mixture being multiplied by the same number to create another mixture that is the same shade.

Learning Targets

- I can explain the meaning of equivalent ratios using a color mixture as an example.
- I can use a diagram to represent a single batch, a double batch, and a triple batch of a color mixture.
- I know what it means to double or triple a color mixture.

Lesson Narrative

This is the second of two lessons that help students make sense of equivalent ratios through physical experiences. In this lesson, students mix different numbers of batches of a recipe for green water by combining blue and yellow water (created ahead of time with food coloring) to see if they produce the same shade of green. They also change the ratio of blue and yellow water to see if it changes the result. The activities here reinforce the idea that scaling a recipe up (or down) requires scaling the amount of each ingredient by the same factor (MP7). Students continue to use discrete diagrams as a tool to represent a situation.

For students who do not see color, the lesson can be adapted by having students make batches of dough with flour and water. 1 cup of flour to 5 tablespoons of water makes a very stiff dough, and 1 cup of flour to 6 tablespoons of water makes a soft (but not sticky) dough. In this case, doubling a recipe yields dough with the same tactile properties, just as doubling a colored-water recipe yields a mixture with the same color. The invariant property is stiffness rather than color. The principle that equivalent ratios yield products that are identical in some important way applies to both types of experiments.

Alignments

Building On

- 4.NBT.B.5: Multiply a whole number of up to four digits by a one-digit whole number, and multiply two two-digit numbers, using strategies based on place value and the properties of operations. Illustrate and explain the calculation by using equations, rectangular arrays, and/or area models.

Addressing

- 6.RP.A.1: Understand the concept of a ratio and use ratio language to describe a ratio relationship between two quantities. For example, “The ratio of wings to beaks in the bird house at the zoo was 2 : 1, because for every 2 wings there was 1 beak.” “For every vote candidate A received, candidate C received nearly three votes.”

Instructional Routines

- Anticipate, Monitor, Select, Sequence, Connect
- MLR3: Clarify, Critique, Correct
- MLR8: Discussion Supports
- Number Talk
- Think Pair Share

Required Materials

Beakers

Food coloring

Graduated cylinders

Markers

Paper cups

Required Preparation

Mix blue water and yellow water; each group of 2 students will need 1 cup of each. To make colored water, add 1 teaspoon of food coloring to 1 cup of water. It would be best to give each mixture to students in a beaker or another container with a pour spout. If possible, conduct this lesson in a room with a sink.

Note that a digital version of this activity is available at this link: <https://ggbm.at/Hcz2rDHc>. It is embedded in the digital version of the student materials, but if classrooms using the print version of materials have access to enough student devices, it could be used in place of mixing actual colored water.

Student Learning Goals

Let’s see what color-mixing has to do with ratios.

4.1 Number Talk: Adjusting a Factor

Warm Up: 10 minutes

This number talk encourages students to use the structure of base ten numbers and the properties of operations to find the product of two whole numbers (MP7).

While many strategies may emerge, the focus of this string of problems is for students to see how adjusting a factor impacts the product, and how this insight can be used to reason about other problems. Four problems are given, however, it may not be possible to share every possible strategy. Consider gathering only two or three different strategies per problem. Each problem was

chosen to elicit a slightly different reasoning, so as students explain their strategies, ask how the factors impacted how they approached the problem.

Building On

- 4.NBT.B.5

Instructional Routines

- MLR8: Discussion Supports
- Number Talk

Launch

Display one problem at a time. Give students 1 minute of quiet think time per problem and ask them to give a signal when they have an answer and a strategy. Follow with a whole-class discussion.

Support for Students with Disabilities

Representation: Internalize Comprehension. To support working memory, provide students with sticky notes or mini whiteboards.

Supports accessibility for: Memory; Organization

Student Task Statement

Find the value of each product mentally.

$$6 \cdot 15$$

$$12 \cdot 15$$

$$6 \cdot 45$$

$$13 \cdot 45$$

Student Response

- 90. Possible strategy: $(6 \cdot 10) + (6 \cdot 5) = 90$
- 180. Possible strategy: Since the 6 from the first question doubled to 12, and the 15 stayed the same, the product doubles to 180. This is because there are twice as many groups of 15 than in the first question.
- 270. Possible strategy: Since the 6 is the same as the in the first question, and the 15 tripled to 45, the product triples to 270. This is because the number of groups stayed the same, but the amount in each group got three times as large.

- 585. Possible strategy: Since the 45 is the same as the previous question, we can double the 6 and the product to get 540. We need one more group of 45, and $540 + 45 = 585$.

Activity Synthesis

Ask students to share their strategies for each problem. Record and display their explanations for all to see. Ask students if or how the factors in the problem impacted the strategy choice. To involve more students in the conversation, consider asking:

- “Who can restate ___’s reasoning in a different way?”
- “Did anyone solve the problem the same way but would explain it differently?”
- “Did anyone solve the problem in a different way?”
- “Does anyone want to add on to ___’s strategy?”
- “Do you agree or disagree? Why?”

Support for English Language Learners

Speaking: MLR8 Discussion Supports: Display sentence frames to support students when they explain their strategy. For example, “First, I ___ because . . .” or “I noticed ___ so I . . .” Some students may benefit from the opportunity to rehearse what they will say with a partner before they share with the whole class.

Design Principle(s): Optimize output (for explanation)

4.2 Turning Green

35 minutes (there is a digital version of this activity)

In this activity, students mix different numbers of batches of a color recipe to obtain a certain shade of green. They observe how multiple batches of the same recipe produce the same shade of green as a single batch, which suggests that the ratios of blue to yellow for the two situations are equivalent. They also come up with a ratio that is not equivalent to produce a mixture that is a different shade of green.

As students make the mixtures, ensure that they measure accurately so they will get accurate outcomes. As students work, note the different diagrams students use to represent their recipes. Select a few examples that could be highlighted in discussion later.

Addressing

- 6.RP.A.1

Instructional Routines

- MLR8: Discussion Supports

Launch

Arrange students in groups of 2–4. (Smaller groups are better, but group size might depend on available equipment.) Each group needs a beaker of blue water and one of yellow water, one graduated cylinder, a permanent marker, a craft stick, and 3 opaque white cups (either styrofoam, white paper, or with a white plastic interior).

For classes using the print-only version: Show students the blue and yellow water. Demonstrate how to pour from the beakers to the graduated cylinder to measure and mix 5 ml of blue water with 15 ml of yellow water. Demonstrate how to get an accurate reading on the graduated cylinder by working on a level surface and by reading the measurement at eye level. Tell students they will experiment with different mixtures of green water and observe the resulting shades.

For classes using the digital version: Display the dynamic color mixing cylinders for all to see. Tell students, “The computer mixes colors when you add colored water to each cylinder. You can add increments of 1 or 5. You can’t remove water (once it’s mixed, it’s mixed), but you can start over. The computer mixes yellow and blue.” Ask students a few familiarization questions before they start working on the activity:

- What happens when you mix yellow and blue? (A shade of green is formed.)
- What happens if you add more blue than yellow? (Darker green, blue green, etc.)

If necessary, demonstrate how it works by adding some yellows and blues to both the left and the right cylinder. Show how the “Reset” button lets you start over.

Support for Students with Disabilities

Representation: Internalize Comprehension. Provide appropriate reading accommodations and supports to ensure students access to written directions, word problems and other text-based content.

Supports accessibility for: Language; Conceptual processing

Anticipated Misconceptions

If any students come up with an incorrect recipe, consider letting this play out. A different shade of green shows that the ratio of blue to yellow in their mixture is not equivalent to the ratio of blue to yellow in the other mixtures. Rescuing the incorrect mixture to display during discussion may lead to meaningful conversations about what equivalent ratios mean.

Student Task Statement

Your teacher mixed milliliters of blue water and milliliters of yellow water in the ratio 5 : 15.

1. Doubling the original recipe:

- a. Draw a diagram to represent the amount of each color that you will combine to double your teacher's recipe.
 - b. Use a marker to label an empty cup with the ratio of blue water to yellow water in this double batch.
 - c. Predict whether these amounts of blue and yellow will make the same shade of green as your teacher's mixture. Next, check your prediction by measuring those amounts and mixing them in the cup.
 - d. Is the ratio in your mixture equivalent to the ratio in your teacher's mixture? Explain your reasoning.
2. Tripling the original recipe:
- a. Draw a diagram to represent triple your teacher's recipe.
 - b. Label an empty cup with the ratio of blue water to yellow water.
 - c. Predict whether these amounts will make the same shade of green. Next, check your prediction by mixing those amounts.
 - d. Is the ratio in your new mixture equivalent to the ratio in your teacher's mixture? Explain your reasoning.
3. Next, invent your own recipe for a *bluer* shade of green water.
- a. Draw a diagram to represent the amount of each color you will combine.
 - b. Label the final empty cup with the ratio of blue water to yellow water in this recipe.
 - c. Test your recipe by mixing a batch in the cup. Does the mixture yield a bluer shade of green?
 - d. Is the ratio you used in this recipe equivalent to the ratio in your teacher's mixture? Explain your reasoning.

Student Response

1. Doubling the recipe.
 - a. Here is one example of a diagram. Students may arrange the groups differently or use different symbols to represent 1 ml of water.

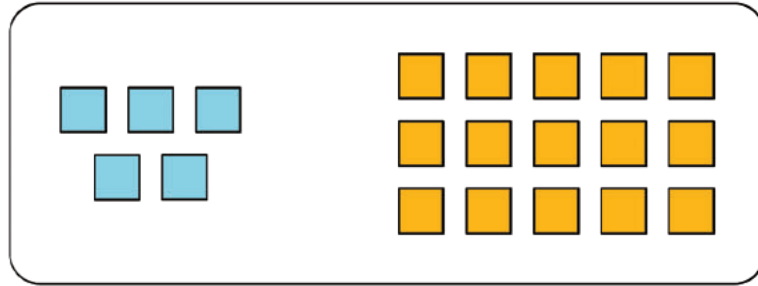
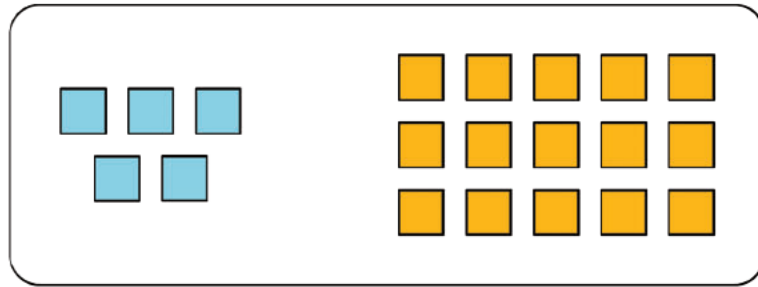

- b. A cup is labeled 10 : 30 or "10 to 30."
 - c. If the recipe is correct, the shade of green is identical to the teacher's.
 - d. 10 : 30 is equivalent to 5 : 15 because it is 2 batches of the same recipe. It creates an identical shade of green.
2. Tripling the recipe.
- a. Like the previous diagram, except showing 3 batches.
 - b. A cup is labeled 15 : 45 or "15 to 45."
 - c. If the recipe is correct, the shade of green is identical to the teacher's.
 - d. 15 : 45 is equivalent to 5 : 15 because it is 3 batches of the same recipe. It creates an identical shade of green.

3. A bluer shade of green.

- a. Answers vary. You might use more blue for the same amount of yellow, or less yellow for the same amount of blue. Sample response:

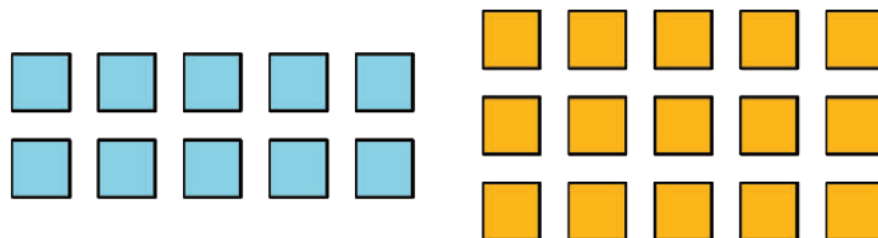

- b. Answers vary. Sample responses: 10 : 15 (more blue for the same amount of yellow) or 5 : 10 (less yellow for the same amount of blue).

- c. If a correct ratio is used, the mixture should be a bluer shade of green than the other mixtures.
- d. No, it was not the same shade of green. The first and second parts were not, respectively, obtained by multiplying 5 and 15 by the same number.

Are You Ready for More?

Someone has made a shade of green by using 17 ml of blue and 13 ml of yellow. They are sure it cannot be turned into the original shade of green by adding more blue or yellow. Either explain how more can be added to create the original green shade, or explain why this is impossible.

Student Response

You could add 3 ml of blue to get 20 ml of blue, and 47 ml of yellow to get 60 ml of yellow. The blue to yellow ratio of 20 : 60 will make the same shade of green as 5 : 15. It's a quadruple batch.

Activity Synthesis

After each group has completed the task, have the students rotate through each group's workspace to observe the mixtures and diagrams. As they circulate, pose some guiding questions. (For students using the digital version, these questions refer to the mixtures on their computers.)

- Are each group's results for the first two mixtures the same shade of green?
- Are the ratios representing the double batch, the triple batch, and your new mixture all equivalent to each other? How do you know?
- What are some different ways groups drew diagrams to represent the ratios?

Highlight the idea that a ratio is equivalent to another if the two ratios describe different numbers of batches of the same recipe.

Support for English Language Learners

Conversing: MLR8 Discussion Supports. Assign one member from each group to stay behind to answer questions from students visiting from other groups. Provide visitors with question prompts such as, "These look like the same shade, how can we be sure the ratios are equivalent?", "If you want a smaller amount with the same shade, what can you do?" or "What is the ratio for your new mixture?"

Design Principle(s): Cultivate conversation

4.3 Perfect Purple Water

Optional: 10 minutes

Students revisit color mixing—this time by producing purple-colored water—to further understand equivalent ratios. They recall that doubling, tripling, or halving a recipe for colored water yields the same resulting color, and that equivalent ratios can represent different numbers of batches of the same recipe.

As students work, monitor for students who use different representations to answer both questions, as well as students who come up with different ratios for the second question.

Addressing

- 6.RP.A.1

Instructional Routines

- Anticipate, Monitor, Select, Sequence, Connect
- MLR3: Clarify, Critique, Correct
- Think Pair Share

Launch

Arrange students in groups of 2. Remind students of the previous “Turning Green” activity. Ask students to discuss the following questions with a partner. Then, discuss responses together as a whole class:

- Why did the different mixtures of blue and yellow water result in the same shade of green? (If mixed correctly, the amount of the ingredients were all doubled or all tripled. The ratio of blue water to yellow water was equivalent within each recipe.)
- How were you able to get a darker shade of green? (We changed the ratio of ingredients, so there was more blue for the same amount of yellow.)

Explain to students that the task involves producing purple-colored water, but they won’t actually be mixing colored water. Ask students to use the ideas just discussed from the previous activity to predict the outcomes of mixing blue and red water.

Ensure students understand the abbreviation for milliliters is ml.

Support for Students with Disabilities

Representation: Develop Language and Symbols. Use virtual or concrete manipulatives to connect symbols to concrete objects or values. Provide students with snap cubes, blocks or printed representations.

Supports accessibility for: Conceptual processing

Anticipated Misconceptions

At a quick glance, students may think that since Andre is mixing a multiple of 8 with a multiple of 3, it will also result in Perfect Purple Water. If this happens, ask them to take a closer look at how the values are related or draw a diagram showing batches.

Student Task Statement

The recipe for Perfect Purple Water says, "Mix 8 ml of blue water with 3 ml of red water."

Jada mixes 24 ml of blue water with 9 ml of red water. Andre mixes 16 ml of blue water with 9 ml of red water.

1. Which person will get a color mixture that is the same shade as Perfect Purple Water? Explain or show your reasoning.
2. Find another combination of blue water and red water that will also result in the same shade as Perfect Purple Water. Explain or show your reasoning.

Student Response

1. Jada's mixture will result in the same shade of purple, because both ingredients were tripled. $8 \cdot 3 = 24$ and $3 \cdot 3 = 9$. Andre's mixture will not result in the same shade of purple, because the amount of red water is doubled, but the amount of blue water was tripled.
2. Answers vary. One possible answer is 16 : 6 (each ingredient is doubled or multiplied by 2. $8 \cdot 2 = 16$, there are 16 ml blue. $3 \cdot 2 = 6$, there are 6 ml red.)

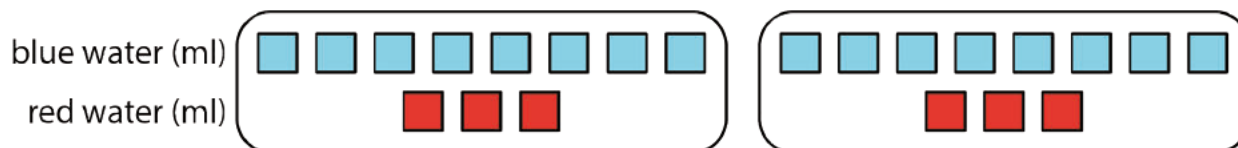

Activity Synthesis

Select students to share their answers to the questions.

- For the first question, emphasize that not only did Jada triple each amount of red and blue, but this means that amount of each color is being *multiplied by the same value*, in this case, 3.
- For the second question, list all the different ratios students brought up for all to see. Discuss how each ratio differed from that for the original mixture. Point out that as long as both terms are multiplied by the same quantity, the resulting ratio will be *equivalent* and will yield the same shade of purple.

Support for English Language Learners

Reading, Writing, Speaking: MLR3 Clarify, Critique, Correct. Before students share their combination of blue water and red water that will make the same shade as Perfect Purple Water, present a flawed response. For example, “Mixing 18 ml of blue water with 13 ml of red water would result in the same shade of purple because I added 10 ml of each color.” Ask students to identify the error, critique the reasoning, and write a correct explanation. Invite students to share their critiques and corrected combinations and explanations with the class. Listen for and amplify the language students use to justify the ratios are equivalent. This may include such language as multiply by the same quantity or represent the same shade. This helps students evaluate, and improve upon, the written mathematical arguments of others, as they clarify their understanding of equivalent ratios.

Design Principle(s): Optimize output (for explanation); Maximize meta-awareness

Lesson Synthesis

The important take-aways from this lesson are:

- To create more batches of a color recipe that will come out to be the same shade of the color, multiply each ingredient by the same number.
- We can think of equivalent ratios as representing different numbers of batches of the same recipe.

Remind students of the work done and observations made in this lesson. Some questions to guide the discussion might include:

- How did you decide that 10 ml blue and 30 ml yellow would make 2 batches of 5 ml blue and 15 ml yellow? (Multiply each part by 2.)
- How did you decide that 15 ml blue and 45 ml yellow would make 3 batches? (Multiply each part by 3.)
- How did we know that $5 : 15$, $10 : 30$, and $15 : 45$ were equivalent? (They created the same shade of green. Also, $10 : 30$ has both parts of the original recipe multiplied by 2, and $15 : 45$ has both parts of the original recipe multiplied by 3.)

4.4 Orange Water

Cool Down: 5 minutes

Addressing

- 6.RP.A.1

Student Task Statement

A recipe for orange water says, "Mix 3 teaspoons yellow water with 1 teaspoon red water." For this recipe, we might say: "The ratio of teaspoons of yellow water to teaspoons of red water is 3 : 1."

1. Write a ratio for 2 batches of this recipe.
2. Write a ratio for 4 batches of this recipe.
3. Explain why we can say that any two of these three ratios are equivalent.

Student Response

1. The ratio of teaspoons of yellow to teaspoons of red is 6 : 2 (or any sentence that accurately states this ratio). Note: a statement like "The ratio of yellow to red is 6 : 2" describes the association between the colors but does not indicate the amount of stuff in the mixture.
2. The ratio of teaspoons of yellow to teaspoons of red is 12 : 4 (or any sentence that accurately states this ratio).
3. These are equivalent ratios because they describe different numbers of batches of the same recipe. To make 2 batches, multiply the amount of each color by 2. To make 4 batches, multiply the amount of each color by 4. As long as you multiply the amounts for both colors by the same number, you will get a ratio that is equivalent to the ratio in the recipe.

Student Lesson Summary

When mixing colors, doubling or tripling the amount of each color will create the same shade of the mixed color. In fact, you can always multiply the amount of *each* color by *the same number* to create a different amount of the same mixed color.

For example, a batch of dark orange paint uses 4 ml of red paint and 2 ml of yellow paint.

- To make two batches of dark orange paint, we can mix 8 ml of red paint with 4 ml of yellow paint.
- To make three batches of dark orange paint, we can mix 12 ml of red paint with 6 ml of yellow paint.

Here is a diagram that represents 1, 2, and 3 batches of this recipe.

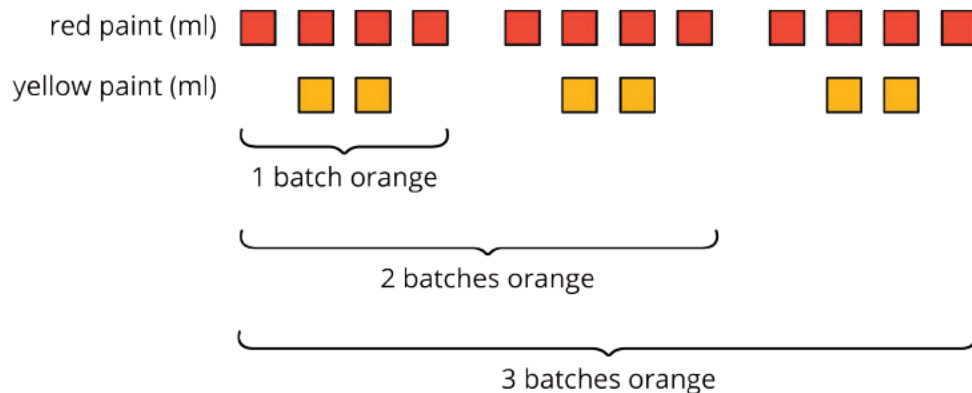

We say that the ratios $4 : 2$, $8 : 4$, and $12 : 6$ are *equivalent* because they describe the same color mixture in different numbers of batches, and they make the same shade of orange.

Lesson 4 Practice Problems

Problem 1

Statement

Here is a diagram showing a mixture of red paint and green paint needed for 1 batch of a particular shade of brown.



Add to the diagram so that it shows 3 batches of the same shade of brown paint.

Solution

Answers vary. Sample response:

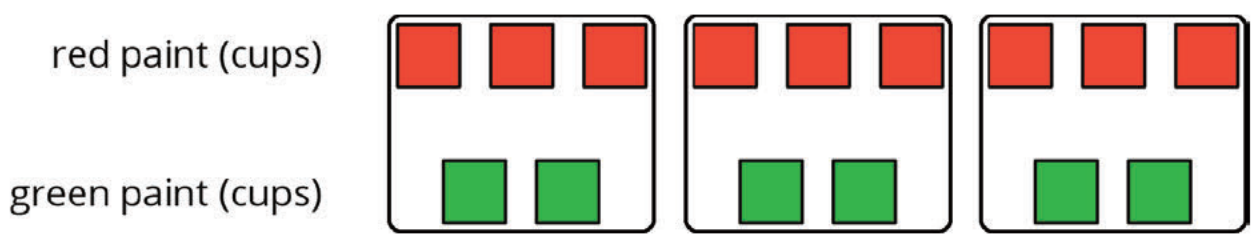

Problem 2

Statement

Diego makes green paint by mixing 10 tablespoons of yellow paint and 2 tablespoons of blue paint. Which of these mixtures produce the same shade of green paint as Diego's mixture? Select **all** that apply.

- A. For every 5 tablespoons of blue paint, mix in 1 tablespoon of yellow paint.
- B. Mix tablespoons of blue paint and yellow paint in the ratio 1 : 5.
- C. Mix tablespoons of yellow paint and blue paint in the ratio 15 to 3.
- D. Mix 11 tablespoons of yellow paint and 3 tablespoons of blue paint.
- E. For every tablespoon of blue paint, mix in 5 tablespoons of yellow paint.

Solution

["B", "C", "E"]

Problem 3

Statement

To make 1 batch of sky blue paint, Clare mixes 2 cups of blue paint with 1 gallon of white paint.

- a. Explain how Clare can make 2 batches of sky blue paint.
- b. Explain how to make a mixture that is a darker shade of blue than the sky blue.
- c. Explain how to make a mixture that is a lighter shade of blue than the sky blue.

Solution

- a. Mix 4 cups of blue paint and 2 gallons of white paint.
- b. Answers vary. Sample response: 3 cups of blue paint and 1 gallon of white paint. Mixing the same amount of white paint with *more* blue paint will make a darker shade of blue.
- c. Answers vary. Sample response: 2 cups of blue paint and 2 gallons of white paint. Mixing the same amount of blue paint with *more* white paint will make a lighter shade of blue.

Problem 4

Statement

A smoothie recipe calls for 3 cups of milk, 2 frozen bananas and 1 tablespoon of chocolate syrup.

- a. Create a diagram to represent the quantities of each ingredient in the recipe.
- b. Write 3 different sentences that use a ratio to describe the recipe.

Solution

- a. Answers vary. Sample response:

cups of milk

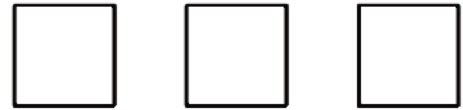

number of bananas



tablespoons of chocolate syrup



2. Answers vary. Sample response: The ratio of cups of milk to number of bananas is 3 : 2, the ratio of bananas to tablespoons of chocolate syrup is 2 to 1, for every tablespoon of chocolate syrup, there are 3 cups of milk.

(From Unit 2, Lesson 2.)

Problem 5

Statement

Write the missing number under each tick mark on the number line.

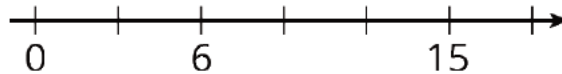

Solution

0, 3, 6, 9, 12, 15, 18 (intervals of 3)

(From Unit 2, Lesson 1.)

Problem 6

Statement

Find the area of the parallelogram. Show your reasoning.

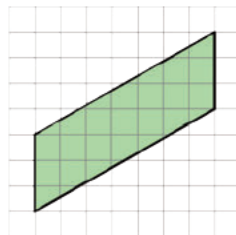

Solution

21 square units. Reasoning varies. Sample reasoning: Draw a square around the parallelogram; its area is 49 square units, because $7 \cdot 7 = 49$. Rearrange the triangles above and below the parallelogram to form a rectangle; the area of this rectangle is 28 square units, because $4 \cdot 7 = 28$. Subtracting the area of the triangles from the area of the square, we have 21 square units. $49 - 28 = 21$.

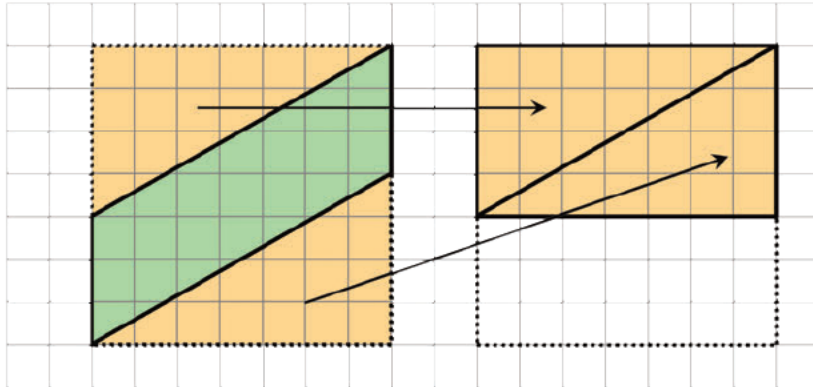

(From Unit 1, Lesson 4.)

Problem 7

Statement

Complete each equation with a number that makes it true.

a. $11 \cdot \frac{1}{4} = \underline{\hspace{2cm}}$

b. $7 \cdot \frac{1}{4} = \underline{\hspace{2cm}}$

c. $13 \cdot \frac{1}{27} = \underline{\hspace{2cm}}$

a. $13 \cdot \frac{1}{99} = \underline{\hspace{2cm}}$

b. $x \cdot \frac{1}{y} = \underline{\hspace{2cm}}$

(As long as y does not equal 0.)

Solution

a. $\frac{11}{4}$ (or equivalent)

b. $\frac{7}{4}$ (or equivalent)

c. $\frac{13}{27}$ (or equivalent)

d. $\frac{13}{99}$ (or equivalent)

e. $\frac{x}{y}$ (or equivalent)

(From Unit 2, Lesson 1.)

Lesson 5: Defining Equivalent Ratios

Goals

- Generate equivalent ratios and justify that they are equivalent.
- Present (in words and through other representations) a definition of equivalent ratios, including examples and non-examples.

Learning Targets

- If I have a ratio, I can create a new ratio that is equivalent to it.
- If I have two ratios, I can decide whether they are equivalent to each other.

Lesson Narrative

Previously, students understood equivalent ratios through physical perception of different batches of recipes. In this lesson, they work with equivalent ratios more abstractly, both in the context of recipes and in the context of abstract ratios of numbers. They understand and articulate that all ratios that are **equivalent** to $a : b$ can be generated by multiplying both a and b by the same number (MP6).

By connecting concrete quantitative experiences to abstract representations that are independent of a context, students develop their skills in reasoning abstractly and quantitatively (MP2). They continue to use diagrams, words, or a combination of both for their explanations. The goal in subsequent lessons is to develop a general definition of **equivalent ratios**.

Alignments

Building On

- 3.OA: Grade 3 - Operations and Algebraic Thinking

Addressing

- 6.RP.A.1: Understand the concept of a ratio and use ratio language to describe a ratio relationship between two quantities. For example, “The ratio of wings to beaks in the bird house at the zoo was 2 : 1, because for every 2 wings there was 1 beak.” “For every vote candidate A received, candidate C received nearly three votes.”

Instructional Routines

- Group Presentations
- MLR1: Stronger and Clearer Each Time
- MLR8: Discussion Supports

Required Materials

Tools for creating a visual display

Any way for students to create work that can be easily displayed to the class. Examples: chart

paper and markers, whiteboard space and markers, shared online drawing tool, access to a document camera.

Student Learning Goals

Let's investigate equivalent ratios some more.

5.1 Dots and Half Dots

Warm Up: 10 minutes

In this warm-up, students are asked to determine the number of dots in an image and explain how they arrived at that answer. The goal is to prompt students to visualize and articulate different ways in which they can decompose the dots, using what they know about arrays, symmetry, and multiplication to arrive at the total number of dots. To encourage students to refer to the image in their explanation but not count every dot, this image is flashed for a few seconds and then hidden. It is flashed once more for students to check their thinking. Ask students how they *saw* the dots instead of how they *found* the number of dots, so they focus on the structure of the dots in the image.

As students share how they saw the dots, ask how the expressions they used to describe the arrangements and grouping of the dots in the two problems are similar. This prompts students to make connections between the properties of multiplication.

Building On

- 3.OA

Launch

Tell students you will show them an image made up of dots for 3 seconds. Their job is to find how many dots are in the image and explain how they saw them. Display the image for all to see for 3 seconds and then hide it. Do this twice. Give students 1 minute of quiet think time between each flash of the image. Encourage students who have one way of seeing the dots to think of another way while they wait.

Support for Students with Disabilities

Representation: Internalize Comprehension. Guide information processing and visualization. To support working memory, show the image for a longer period of time or repeat the image flash as needed. Students may also benefit from being explicitly told not to count the dots, but instead to look for helpful structure within the image.

Supports accessibility for: Memory; Organization

Student Task Statement

Dot Pattern 1:

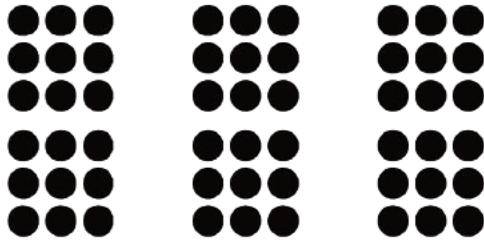

Dot Pattern 2:

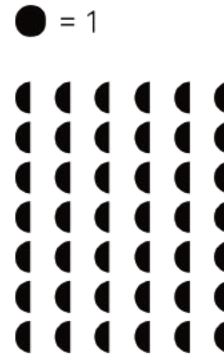

Student Response

Dot pattern 1: 54 dots. Answers vary. Possible strategies:

6 groups with a 3 by 3 array in each group $6 \cdot 3 \cdot 3 = 54$

3 groups with two group of 9 in each group $3 \cdot 2 \cdot 9 = 54$

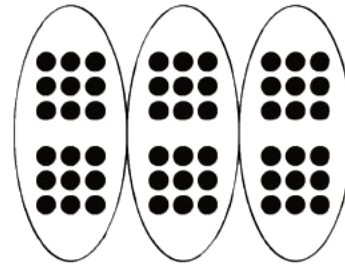
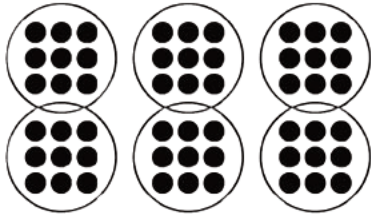

Dot pattern 2: 21 dots. Answers vary. Possible strategies:

6 groups with 3 and a half in each group $6 \cdot 3\frac{1}{2} = 21$

3 groups with 7 in each group $3 \cdot 7 = 21$

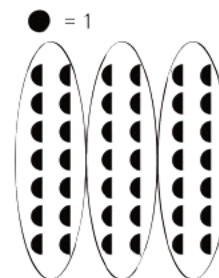
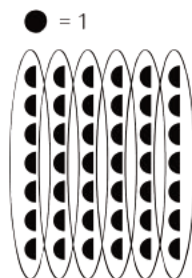

Activity Synthesis

Ask students to share how many dots they saw and how they saw them. Record and display student explanations for all to see. (Consider re-displaying the image for reference while students are explaining what they saw.) To involve more students in the conversation, consider asking:

- “Who can restate the way ___ saw the dots in different words?”
- “Did anyone see the dots the same way but would explain it differently?”
- “Does anyone want to add an observation to the way ___ saw the dots?”
- “Who saw the dots differently?”
- “Do you agree or disagree? Why?”

5.2 Tuna Casserole

15 minutes

Students use a realistic food recipe to find equivalent ratios that represent different numbers of batches. Students use the original recipe to form ratios of ingredients that represent double, half, five times, and one-fifth of the recipe. Then they examine given ratios of ingredients and determine how many batches they represent.

Addressing

- 6.RP.A.1

Instructional Routines

- MLR8: Discussion Supports

Launch

Ask students if they have ever cooked something by following a recipe. If so, ask them what they made and what some of the ingredients were.

Ask: “How might we use ratios to describe the ingredients in your recipe?” (The ratios could associate the quantities of each ingredient being used.)

Explain to students that in this task, they will think about the ratios of ingredients for a tuna casserole and how to adjust them for making different numbers of batches.

Support for Students with Disabilities

Action and Expression: Internalize Executive Functions. To support development of organizational skills in problem solving, chunk this task into more manageable parts. For example, provide students with a task checklist which makes all the required components of the activity explicit.
Supports accessibility for: Memory; Organization

Support for English Language Learners

Listening: MLR8 Discussion Supports. When asking the question, "How might we use ratios to describe the ingredients in your recipe?", act out or use images that demonstrate the meaning of the terms "ratio", "recipe", and "ingredients" in the context of cooking. Demonstrate combining specific ingredients in their stated ratios. This will help students connect the language found in a recipe with the ratio reasoning needed for different batches of that recipe.
Design Principle(s): Support sense-making

Anticipated Misconceptions

Students who are not yet fluent in fraction multiplication from grade 5 may have difficulty understanding how to find half or one-fifth of the recipe ingredient amounts. Likewise, they may have difficulty identifying one-third of a batch. Suggest that they draw a picture of $\frac{1}{2}$ of 10, remind them that finding $\frac{1}{2}$ of a number is the same as dividing it by 2, or remind them that $\frac{1}{2}$ of a number means $\frac{1}{2}$ times that number.

Student Task Statement

Here is a recipe for tuna casserole.

Ingredients

- 3 cups cooked elbow-shaped pasta
- 6 ounce can tuna, drained
- 10 ounce can cream of chicken soup
- 1 cup shredded cheddar cheese
- $1\frac{1}{2}$ cups French fried onions

Instructions



Combine the pasta, tuna, soup, and half of the cheese. Transfer into a 9 inch by 18 inch baking dish. Put the remaining cheese on top. Bake 30 minutes at 350 degrees. During the last 5 minutes, add the French fried onions. Let sit for 10 minutes before serving.

1. What is the ratio of the ounces of soup to the cups of shredded cheese to the cups of pasta in one batch of casserole?
2. How much of each of these 3 ingredients would be needed to make:
 - a. twice the amount of casserole?
 - b. half the amount of casserole?
 - c. five times the amount of casserole?
 - d. one-fifth the amount of casserole?
3. What is the ratio of cups of pasta to ounces of tuna in one batch of casserole?
4. How many batches of casserole would you make if you used the following amounts of ingredients?
 - a. 9 cups of pasta and 18 ounces of tuna?
 - b. 36 ounces of tuna and 18 cups of pasta?
 - c. 1 cup of pasta and 2 ounces of tuna?

Student Response

1. The ratio of the ounces of soup to cups of shredded cheese to cups of pasta is 10 : 1 : 3.
2. The ratio of these ingredients for different numbers of batches are:
 - a. 20 ounces, 2 cups, 6 cups
 - b. 5 ounces, $\frac{1}{2}$ cup, $1\frac{1}{2}$ cups
 - c. 50 ounces, 5 cups, 15 cups
 - d. 2 ounces, $\frac{1}{5}$ cup, $\frac{3}{5}$ cup
3. The ratio of cups of pasta to ounces of tuna is 3 : 6.
4.
 - a. 3 batches
 - b. 6 batches
 - c. $\frac{1}{3}$ batch

Are You Ready for More?

The recipe says to use a 9 inch by 18 inch baking dish. Determine the length and width of a baking dish with the same height that could hold:

1. Twice the amount of casserole
2. Half the amount of casserole
3. Five times the amount of casserole
4. One-fifth the amount of casserole

Student Response

Answers vary. Sample responses:

1. 18 inch by 18 inch
2. 9 inch by 9 inch
3. 45 inch by 18 inch
4. 9 inch by $\frac{18}{5}$ inch

Activity Synthesis

Display the recipe for all to see. Ask students to share and explain their responses. List their responses—along with the specified number of batches—for all to see. Ask students to analyze the list and describe how the ratio of quantities relate to the number of batches in each case. Draw out the idea that each quantity within the recipe was *multiplied* by a number to obtain each batch size, and that each ingredient amount is multiplied by the *same* value.

In finding one-half and one-fifth of a batch, students may speak in terms of dividing by 2 and dividing by 5. Point out that “dividing by 2” has the same outcome as “multiplying by one-half,” and “dividing by 5” has the same outcome as “multiplying by one-fifth.” (Students multiplied a whole number by a fraction in grade 5.) Later, we will want to state our general definition of equivalent ratios as simply as possible: as *multiplying* both a and b in the ratio $a : b$ by the same number (not “multiplying or dividing”).

5.3 What Are Equivalent Ratios?

15 minutes

In this activity, students identify what equivalent ratios have in common (a ratio equivalent to $a : b$ can be generated by multiplying both a and b by the same number) and generate equivalent ratios (MP8). It is at this point in the unit where students will explicitly define the term equivalent ratios (MP6).

Addressing

- 6.RP.A.1

Instructional Routines

- Group Presentations
- MLR1: Stronger and Clearer Each Time

Launch

Arrange students in groups of 3–4. Provide each group with tools for creating a visual display.

Summarize what we know so far about equivalent ratios. When we double or triple a color recipe, the ratios of the amount of ingredients in the mixtures are equivalent to those in the original recipe. For example, $24 : 9$ and $8 : 3$ are equivalent ratios, because we can think of $24 : 9$ as a mixture that contains three batches of purple water where a single batch is $8 : 3$.

When we make multiple batches of a food recipe, we say the ratios of the amounts of the ingredients are equivalent to the ratios in a single batch. For example, $3 : 6$, $1 : 2$, and $9 : 18$ are equivalent ratios because they correspond to the amount of the ingredients in different numbers of batches of tuna noodle casserole, and they all taste the same.

In this activity, we'll write a definition for **equivalent ratios**.

When students pause after question 5, have a whole class discussion about the first five questions. Then assign each group a different ratio to use as their example for their visual display. Some possibilities:

$4 : 5$

$3 : 2$

$5 : 6$

$3 : 4$

$2 : 5$

Support for English Language Learners

Writing and speaking: Math Language Routine 1 Stronger and Clearer Each Time. This is the first time Math Language Routine 1 is suggested as a support in this course. In this routine, students are given a thought-provoking question or prompt and asked to create a first draft response. Students meet together in 2–3 partners to share and refine their response through conversation. While meeting, listeners ask questions such as: “What did you mean by . . .?” and “Can you say that another way?” Finally, students write a second draft of their response that reflects ideas from their partners, and improvement on their writing. The purpose of this routine is to provide a structured and interactive opportunity for students to revise and refine their ideas through verbal and written means.

Design Principle(s): Optimize output (for generalization)

How It Happens:

1. Use this routine to provide students a structured opportunity to revise and refine their response to “How do you know when ratios are equivalent and when they are not equivalent?” Allow students 2–3 minutes to individually create first draft responses.
2. Invite students to meet with 2–3 other partners for feedback.
Instruct the speaker to begin by sharing their ideas without looking at their written draft, if possible. Provide the listener with these prompts for feedback that will help teams strengthen their ideas and clarify their language: “Can you explain how...?”, “You should expand on...”, “Can you give an example of equivalent ratios?”, and “Could you justify that differently?” Be sure to have the partners switch roles. Allow 1–2 minutes to discuss.
3. Signal for students to move on to their next partner and repeat this structured meeting.
4. Close the partner conversations and invite students to revise and refine their writing in a second draft. Students can borrow ideas and language from each partner to strengthen the final product.
Provide these sentence frames to help students organize their thoughts in a clear, precise way: “I know when ratios are equivalent/not equivalent when....” and “An example of this is...because....”

Here is an example of a second draft:

“I know when ratios are equivalent when I multiply both parts of one ratio by the same number and I get the other ratio. For example, I know that $5 : 3$ is equivalent to $30 : 18$ because when I multiply 5 by 6, I get 30, and when I multiply 3 by 6, I get 18, so 6 is the same number used to multiply both parts. But $5 : 3$ is not equivalent to $15 : 12$ because when I multiply 5 by 3, I get 15, and when I multiply 3 by 4, I get 12. So since a different number is used to multiply to get the second ratio, they’re not equivalent.”

-
5. If time allows, instruct students to compare their first and second drafts. If not, the students can continue on with the lesson by returning to their first partner and creating the visual.
-

Anticipated Misconceptions

Students may incorporate recipes, specific examples, or batch thinking into their definitions. These are important ways of thinking about equivalent ratios, but challenge them to come up with a definition that only talks about the numbers involved and not what the numbers represent.

If groups struggle to get started thinking generally about a definition, give them a head start with: “A ratio is equivalent to $a : b$ when . . .”

If students include “or divide” in their definition, remind them that, for example, dividing by 5 gives the same result as multiplying by one-fifth. Therefore, we can just use “multiply” in our definition.

Student Task Statement

The ratios $5 : 3$ and $10 : 6$ are **equivalent ratios**.

1. Is the ratio $15 : 12$ equivalent to these? Explain your reasoning.
2. Is the ratio $30 : 18$ equivalent to these? Explain your reasoning.
3. Give two more examples of ratios that are equivalent to $5 : 3$.
4. How do you know when ratios are equivalent and when they are *not* equivalent?
5. Write a definition of *equivalent ratios*.

Pause here so your teacher can review your work and assign you a ratio to use for your visual display.

6. Create a visual display that includes:

- the title “Equivalent Ratios”
- your best definition of *equivalent ratios*
- the ratio your teacher assigned to you
- at least two examples of ratios that are equivalent to your assigned ratio
- an explanation of how you know these examples are equivalent
- at least one example of a ratio that is *not* equivalent to your assigned ratio
- an explanation of how you know this example is *not* equivalent

Be prepared to share your display with the class.

Student Response

1. $15 : 12$ is not equivalent to $5 : 3$ because 15 is $5 \cdot 3$ but 12 is $3 \cdot 4$.
2. $30 : 18$ is equivalent to $5 : 3$ because 30 is $5 \cdot 6$ and 18 is $3 \cdot 6$.
3. Answers vary and might include $15 : 9$, $20 : 12$, and $50 : 30$.
4. Answers vary and should include some version of “multiply both parts by the same number.”
5. Answers vary. Sample response: A ratio is equivalent to $a : b$ when both a and b are multiplied by the same number.
6. Answers vary.

Activity Synthesis

Each group will share their visual display as they explain their definitions. Highlight phrases or explanations that are similar in each display. Make one class display that incorporates all valid definitions. This display should be kept posted in the classroom for the remaining lessons within this unit. It should look something like:

Equivalent Ratio A ratio is equivalent to $a : b$ when both a and b are multiplied by the same number.

Lesson Synthesis

In this lesson you came to an understanding of what **equivalent ratios** are.

Discuss:

- How do you make different amounts of a colored-water mixture that have the same color? (The amount of each color being mixed must be multiplied by the same value.)
- If you want to make a different amount of a food recipe, how can you ensure that the resulting food will taste the same? (Each ingredient in the recipe must be multiplied by the same value.)

- What are equivalent ratios and how are they generated? (Each number is multiplied by the same value.)

5.4 Why Are They Equivalent?

Cool Down: 5 minutes

Addressing

- 6.RP.A.1

Anticipated Misconceptions

If students are not clear about the meaning of equivalent ratios, refer them to the visual displays created in the previous activity.

Student Task Statement

1. Write another ratio that is equivalent to the ratio 4 : 6.
2. How do you know that your new ratio is equivalent to 4 : 6? Explain or show your reasoning.

Student Response

1. Answers vary. Sample responses: 2 : 3, 16 : 24, 400 : 600.
2. Answers vary. 2 : 3 is equivalent to 4 : 6 because both 4 and 6 are multiplied by $\frac{1}{2}$. 16 : 24 is equivalent because both 4 and 6 are multiplied by 4. 400 : 600 is equivalent because both 4 and 6 are multiplied by 100.

Student Lesson Summary

All ratios that are **equivalent** to $a : b$ can be made by multiplying both a and b by the same number.

For example, the ratio 18 : 12 is equivalent to 9 : 6 because both 9 and 6 are multiplied by the same number: 2.

3 : 2 is also equivalent to 9 : 6, because both 9 and 6 are multiplied by the same number: $\frac{1}{3}$.

Is 18 : 15 equivalent to 9 : 6?

No, because 18 is $9 \cdot 2$, but 15 is *not* $6 \cdot 2$.

$$\begin{array}{c} 9 : 6 \\ \cdot 2 \downarrow \downarrow \cdot 2 \\ 18 : 12 \end{array}$$

$$\begin{array}{c} 9 : 6 \\ \cdot \frac{1}{3} \downarrow \downarrow \cdot \frac{1}{3} \\ 3 : 2 \end{array}$$

$$\begin{array}{c} 9 : 6 \\ \cdot 2 \downarrow \downarrow \text{Nope.} \\ 18 : 15 \end{array}$$

Glossary

- equivalent ratios

Lesson 5 Practice Problems

Problem 1

Statement

Each of these is a pair of equivalent ratios. For each pair, explain why they are equivalent ratios or draw a diagram that shows why they are equivalent ratios.

a. $4 : 5$ and $8 : 10$

a. $2 : 7$ and $10,000 : 35,000$

b. $18 : 3$ and $6 : 1$

Solution

Answers vary. Sample response:

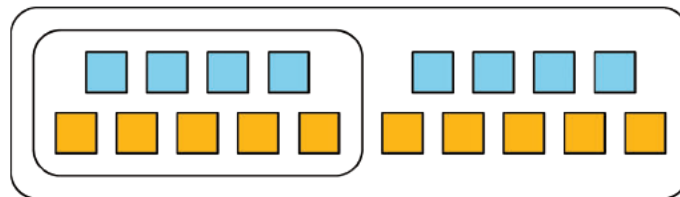

a. The diagram shows that 8 to 10 is the same as 2 groups of 4 to 5 so these are equivalent ratios.

b. $18 \cdot \frac{1}{3} = 6$ and $3 \cdot \frac{1}{3} = 1$.

c. $2 \cdot (5,000) = 10,000$ and $7 \cdot (5,000) = 35,000$.

Problem 2

Statement

Explain why $6 : 4$ and $18 : 8$ are not equivalent ratios.

Solution

Answers vary. Sample response: $6 : 4$ is not equivalent to $18 : 8$ because 18 is $6 \cdot 3$, but 8 is not $4 \cdot 3$.

Problem 3

Statement

Are the ratios $3 : 6$ and $6 : 3$ equivalent? Why or why not?

Solution

Answers vary. Sample response: No, the ratio 3 : 6 is not equivalent to 6 : 3. The ratio 3 : 6 represents 3 of one type of object for every 6 of another type of object while the ratio 6 : 3 represents 6 of the first type of object for every 3 of the second type of object.

Problem 4

Statement

This diagram represents 3 batches of light yellow paint. Draw a diagram that represents 1 batch of the same shade of light yellow paint.

white paint (cups)



yellow paint (cups)



Solution

white paint (cups)



yellow paint (cups)



(From Unit 2, Lesson 4.)

Problem 5

Statement

In the fruit bowl there are 6 bananas, 4 apples, and 3 oranges.

- For every 4 _____, there are 3 _____.
- The ratio of _____ to _____ is 6 : 3.
- The ratio of _____ to _____ is 4 to 6.
- For every 1 orange, there are _____ bananas.

Solution

- apples, oranges
- bananas, oranges
- apples, bananas
- 2

(From Unit 2, Lesson 1.)

Problem 6

Statement

Write fractions for points A and B on the number line.

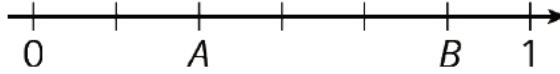

Solution

$$A = \frac{2}{6} \text{ or } \frac{1}{3} \quad B = \frac{5}{6}$$

(From Unit 2, Lesson 1.)

Section: Representing Equivalent Ratios

Lesson 6: Introducing Double Number Line Diagrams

Goals

- Compare and contrast (orally and in writing) discrete diagrams and double number line diagrams representing the same situation.
- Explain (orally) how to use a double number line diagram to find equivalent ratios.
- Label and interpret a double number line diagram that represents a familiar context.

Learning Targets

- I can label a double number line diagram to represent batches of a recipe or color mixture.
- When I have a double number line that represents a situation, I can explain what it means.

Lesson Narrative

This lesson introduces the **double number line diagram**, a useful, efficient, and sophisticated tool for reasoning about equivalent ratios.

The lines in a double number line diagram are similar to the number lines students have seen in earlier grades in that:

- Numbers correspond to distances on the line (so that the distance between, say, 0 and 12 is three times the distance between 0 and 4);
- We can choose what scale to use (i.e., whether each interval represents 1 unit, 2 units, 5 units, etc.);
- The lines can be extended as needed.

In a double number line diagram we use two parallel number lines—one line for each quantity in the ratio—and choose a scale on each line so equivalent ratios line up vertically.

For example, if the ratio of number of eggs to cups of milk in a recipe is 4 to 1, we can draw a number line for the number of eggs and one for the cups of milk. On the number lines, the quantity of 4 for the number of eggs and the 1 for cups of milk would line up vertically, as would 8 eggs and 2 cups of milk, and so on.

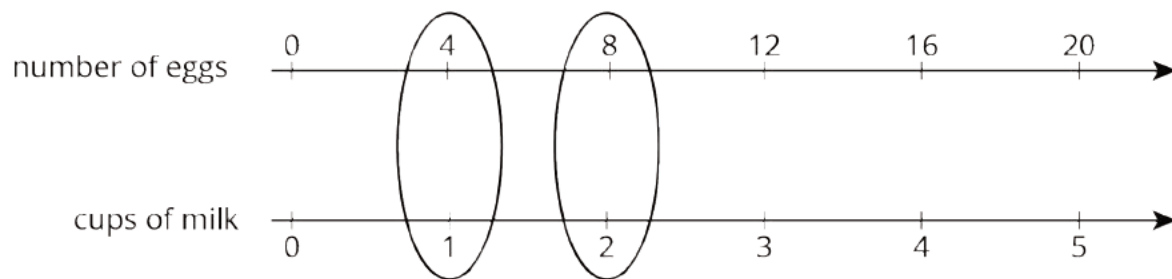

Because they represent quantities with length on a number line rather than with counts of objects, double number lines are both more abstract and more general than discrete diagrams. Later in this unit, students will learn an even more abstract representation of equivalent ratios—the table of values. Connecting the concrete to the abstract helps students connect quantitative reasoning to abstract reasoning (MP2). Though some activities are designed to hone students' facility with particular representations, students should continue to have autonomy in choosing representations to solve problems (MP5), as long as they can explain their meaning (MP3).

Alignments

Building On

- 5.NBT: Grade 5 - Number and Operations in Base Ten

Addressing

- 6.RP.A.3: Use ratio and rate reasoning to solve real-world and mathematical problems, e.g., by reasoning about tables of equivalent ratios, tape diagrams, double number line diagrams, or equations.

Instructional Routines

- Anticipate, Monitor, Select, Sequence, Connect
- MLR1: Stronger and Clearer Each Time
- MLR8: Discussion Supports
- Number Talk
- Think Pair Share

Required Materials

Rulers

Student Learning Goals

Let's use number lines to represent equivalent ratios.

6.1 Number Talk: Adjusting Another Factor

Warm Up: 10 minutes

This Number Talk encourages students to think about the numbers in computation problems and rely on what they know about structure, patterns, whole-number multiplication, and properties of operations to mentally solve a problem.

While many strategies may emerge, the focus of this string of problems is for students to see how adjusting a factor impacts the product, and how this insight can be used to reason about other problems. Four problems are given, however, given limited time, it may not be possible to share every strategy. Consider gathering only two or three different strategies per problem. Each problem was chosen to elicit slightly different reasoning, so as students explain their strategies, ask how the factors impacted their product.

Building On

- 5.NBT

Instructional Routines

- MLR8: Discussion Supports
- Number Talk

Launch

Display one problem at a time. Give students 1 minute of quiet think time per problem and ask them to give a signal when they have an answer and a strategy. Follow with a whole-class discussion.

Support for Students with Disabilities

Representation: Internalize Comprehension. To support working memory, provide students with sticky notes or mini whiteboards.

Supports accessibility for: Memory; Organization

Student Task Statement

Find the value of each product mentally.

$$(4.5) \cdot 4$$

$$(4.5) \cdot 8$$

$$\frac{1}{10} \cdot 65$$

$$\frac{2}{10} \cdot 65$$

Student Response

- $(4.5) \cdot 4 = 18$. Possible strategies: $(4 \cdot 4) + [(0.5) \cdot 4]$, double and halve $9 \cdot 2$.

- $(4.5) \cdot 8 = 36$. Possible strategies: double the product from the first question because a factor doubled; $(8 \cdot 4) + [(0.5) \cdot 8]$.
- $\frac{1}{10} \cdot 65 = 6.5$. Possible strategies: $65 \div 10$, $65 \cdot (0.1)$.
- $\frac{2}{10} \cdot 65 = 13$. Possible strategies: double the product from the previous question because a factor doubled; $65 \div 10 \cdot 2$.

Activity Synthesis

Ask students to share their strategies for each problem. Record and display their explanations for all to see. Ask students if or how the factors in the problem impacted the strategy choice. To involve more students in the conversation, consider asking:

- "Who can restate ___'s reasoning in a different way?"
- "Did anyone solve the problem the same way but would explain it differently?"
- "Did anyone solve the problem in a different way?"
- "Does anyone want to add on to ___'s strategy?"
- "Do you agree or disagree? Why?"

Support for English Language Learners

Speaking: MLR8 Discussion Supports: Display sentence frames to support students when they explain their strategy. For example, "First, I ___ because . . ." or "I noticed ___ so I . . ." Some students may benefit from the opportunity to rehearse what they will say with a partner before they share with the whole class.

Design Principle(s): Optimize output (for explanation)

6.2 Drink Mix on a Double Number Line

15 minutes

In this activity, a double number line, a new representation, is presented and interpreted alongside the more familiar discrete diagrams and in the familiar context of recipes.

Students learn that, just like discrete diagrams, double number lines represent equivalent ratios. They see that alignment between the numbers of the two lines matters; that it is through the alignment that the association of two quantities are shown. Students notice pairs of numbers that "line up" vertically are equivalent ratios.

Because double number lines are quicker to draw and can be extended easily to show many more equivalent ratios, they are more efficient than discrete diagrams, especially for dealing with larger quantities.

As students work, monitor for those who contrast the two representations in terms of using graphic symbols versus numbers, and those who think about equivalent ratios in terms of the alignment of numbers in the double number line diagram.

Addressing

- 6.RP.A.3

Instructional Routines

- MLR8: Discussion Supports
- Think Pair Share

Launch

Ask students to recall the mixture of powdered drink mix and water from a previous lesson. Ask: “How much drink mix and water was in one batch?” (4 teaspoons of drink mix and 1 cup of water.) “What would you need to mix a double batch?” (8 teaspoons of drink mix and 2 cups of water.) Explain that they are going to show batches of a mixture using a **double number line diagram**.

Give students 5 minutes of quiet think time to make sense of the new representation and answer the questions, followed by time to share their response with a partner and a whole-class discussion afterwards.

Support for Students with Disabilities

Engagement: Develop Effort and Persistence. Encourage and support opportunities for peer interactions. Invite students to talk about their ideas with a partner before writing them down. Display sentence frames to support students when they explain their strategy. For example, “The representations are the same/different because ...”

Supports accessibility for: Language; Social-emotional skills

Support for English Language Learners

Reading, Writing: MLR8 Discussion Supports. If necessary, remind students of the meaning of these terms; recipe, batch, mixture, and diagram. This will support student understanding of the context so that they can make sense of the double number line.

Design Principle(s): Support sense-making; Optimize output (for explanation)

Anticipated Misconceptions

While the double number line diagram is given here, some students may not feel comfortable with seeing the same numbers (the 4’s) in different positions. Remind students that each number line represents a different quantity, and that the two 4’s have different meanings.

Student Task Statement

The other day, we made drink mixtures by mixing 4 teaspoons of powdered drink mix for every cup of water. Here are two ways to represent multiple batches of this recipe:

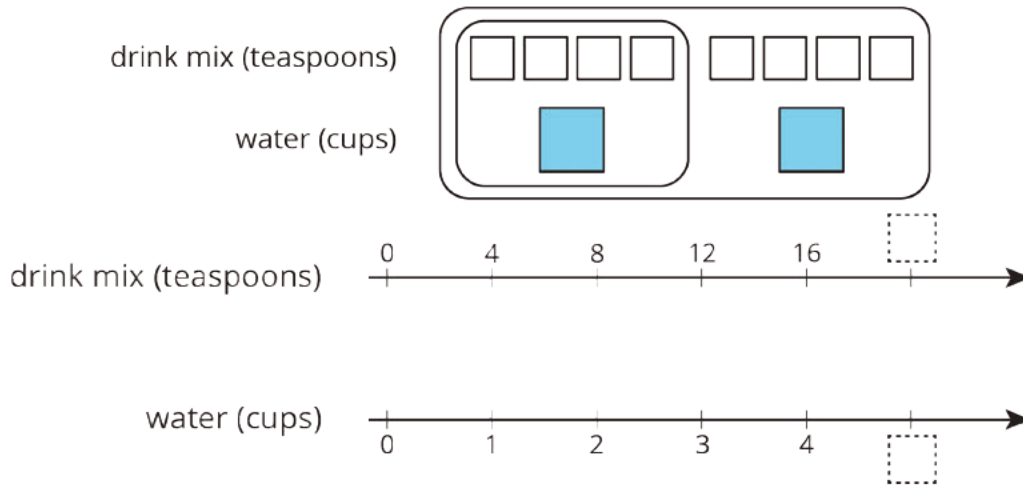

1. How can we tell that $4 : 1$ and $12 : 3$ are equivalent ratios?
2. How are these representations the same? How are these representations different?
3. How many teaspoons of drink mix should be used with 3 cups of water?
4. How many cups of water should be used with 16 teaspoons of drink mix?
5. What numbers should go in the empty boxes on the **double number line diagram**?
What do these numbers mean?

Student Response

1. 12 and 3 are 3 times 4 and 1, respectively. On the number line diagram, you can see that 4 and 1 line up vertically, as do 12 and 3.
2. Same: Each representation shows the amount of drink mix and water for one batch and two batches. They each show teaspoons of drink mix along the top and cups of water along the bottom.
Different: The first diagram uses squares to represent each teaspoon of drink mix and cup of water, but the number line diagram has these amounts written with numbers. The first diagram shows only two batches and the number line diagram shows 0, 1, 2, 3, and 4 batches (with space for 5 batches).
3. 12 teaspoons
4. 4 cups
5. The numbers 20 and 5 should go in the missing places. These numbers mean that the result of mixing 20 teaspoons of drink mix with 5 cups of water would taste the same as the other mixtures, or that these amounts would make 5 batches of the recipe.

Are You Ready for More?

Recall that a *perfect square* is a number of objects that can be arranged into a square. For example, 9 is a perfect square because 9 objects can be arranged into 3 rows of 3. 16 is also a perfect square, because 16 objects can be arranged into 4 rows of 4. In contrast, 12 is not a perfect square because you can't arrange 12 objects into a square.

1. How many whole numbers starting with 1 and ending with 100 are perfect squares?
2. What about whole numbers starting with 1 and ending with 1,000?

Student Response

1. There are 10 perfect squares between 1 and 100, because $1^2 = 1$ and $10^2 = 100$.
2. There are 31 perfect squares between 1 and 1,000, because $31^2 = 961$, but $32^2 = 1,024$.

Activity Synthesis

Select students to share their observations about how the two representations are alike and how they differ. As students discuss solutions to the questions, circle pairs of associated quantities on the double number line. Help students connect information as it is represented in the different diagrams.

On the last question, ask students how they knew that 20 was the next number on the line representing teaspoons of drink mix? (Skip counting by 4; multiply the next number of cups of water by 4.)

Ask students to think more generally for a minute about the representations at hand:

- What is a **double number line diagram**? What do they do? What do the numbers on the tick marks represent and how should they be scaled?
- What might be some benefits of using double number lines instead of diagrams? (We can use them to show many more batches; they are quicker to draw.)

6.3 Blue Paint on a Double Number Line

15 minutes

The purpose of this activity is for students to practice labeling the tick marks on a double number line diagram with equivalent ratios. This activity revisits a familiar context from a previous lesson so students can apply reasoning about different sized batches of a recipe to help them understand the more abstract representation of a double number line diagram.

Some students may interpret the diagram as showing 3 tablespoons of blue paint for every 1 cup of white paint and may choose to label the top line of the double number line diagram counting by 1s instead of 2s and the bottom line counting by 3s instead of 6s. This is also an acceptable correct answer. There are two reasons to monitor for students using this alternate representation. First, when students are comparing their diagrams with their partner if one partner counter by 2s and

the other partner counted by 1s, they may need guidance in determining that these are both correct answers. Second, during the whole-class discussion, consider selecting a student with the less common representation to share their solution at the end.

Addressing

- 6.RP.A.3

Instructional Routines

- Anticipate, Monitor, Select, Sequence, Connect
- MLR1: Stronger and Clearer Each Time

Launch

Give students 4 minutes of quiet work time, followed by time to share their response with a partner and then a whole-class discussion afterwards.

Student Task Statement

Here is a diagram showing Elena's recipe for light blue paint.

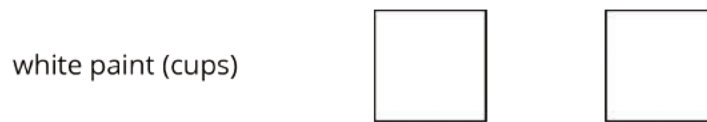

1. Complete the double number line diagram to show the amounts of white paint and blue paint in different-sized batches of light blue paint.

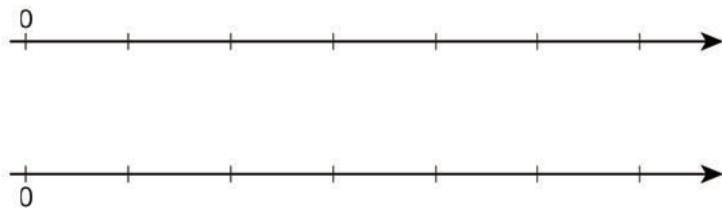

2. Compare your double number line diagram with your partner. Discuss your thinking. If needed, revise your diagram.
3. How many cups of white paint should Elena mix with 12 tablespoons of blue paint? How many batches would this make?
4. How many tablespoons of blue paint should Elena mix with 6 cups of white paint? How many batches would this make?

- Use your double number line diagram to find another amount of white paint and blue paint that would make the same shade of light blue paint.
- How do you know that these mixtures would make the same shade of light blue paint?

Student Response

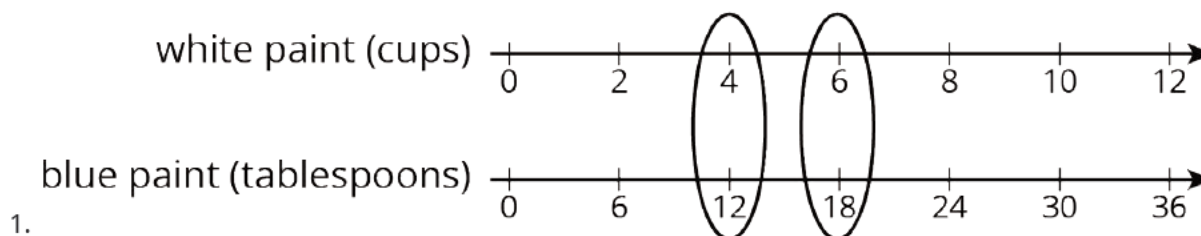

-
- Answers vary.
- 4 cups of white paint, because that is the number on the top line that lines up with the 12 on the bottom line. This would make 2 batches of paint.
- 18 tablespoons of blue paint, because that is the number on the bottom line that lines up with the 6 on the top line. This would make 3 batches of paint.
- Answers vary. Sample responses:
 - 8 cups of white paint and 24 tablespoons of blue paint
 - 10 cups of white paint and 30 tablespoons of blue paint
 - 3 cups of white paint and 9 tablespoons of blue paint
 - 1 cup of white paint and 3 tablespoons of blue paint
- I know these mixtures would make the same shade of light blue paint because the ratios of the amounts of each paint color are equivalent to the ratio in the original recipe.

Activity Synthesis

Select students to present their solutions. Help them connect the different ways in which the information is represented in the different diagrams. Emphasize the importance of labeling everything clearly so the interpretation is easy to make.

Support for English Language Learners

Writing, Conversing: MLR1 Stronger and Clearer Each Time. Use this routine to prepare students for the whole-class discussion by providing them with multiple opportunities to clarify their reasoning through conversation. Before the whole-class discussion begins, give students time to meet with 2–3 partners to share their response to the final question. Display prompts for feedback such as, "Can you explain how you used your double number line diagram?" or "You should expand on" Invite listeners to press for details and mathematical language.

Design Principle(s): Optimize output (for justification); Cultivate conversation

Lesson Synthesis

The main ideas to draw out of this lesson are the reasons for using a **double number line diagram**.

- Double number lines easily display equivalent ratios, with the numbers in each equivalent ratio lining up vertically.
- A double number line diagram can be used when a discrete diagram would be cumbersome or even impossible.

The other major goal of this lesson is building up students' fluency in creating double number lines. Students will have further opportunities in upcoming lessons, but watch for common errors such as inconsistent labeling and failing to align the equivalent ratios.

6.4 Batches of Cookies on a Double Number Line

Cool Down: 5 minutes

Addressing

- 6.RP.A.3

Student Task Statement

A recipe for one batch of cookies uses 5 cups of flour and 2 teaspoons of vanilla.

1. Complete the double number line diagram to show the amount of flour and vanilla needed for 1, 2, 3, 4, and 5 batches of cookies.

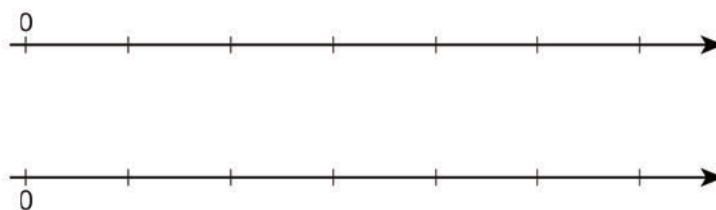

2. If you use 20 cups of flour, how many teaspoons of vanilla should you use?
3. If you use 6 teaspoons of vanilla, how many cups of flour should you use?

Student Response

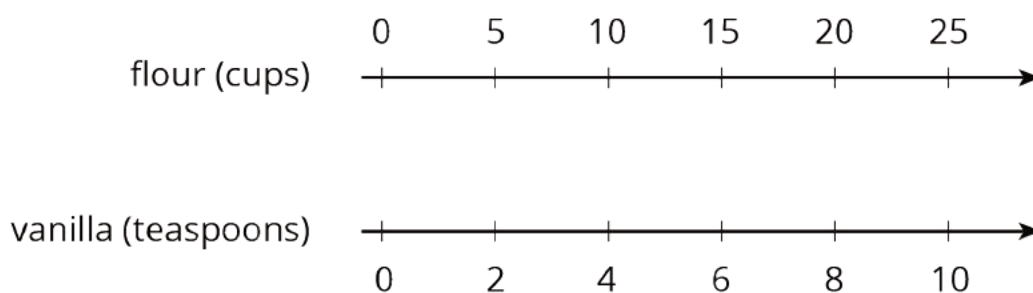

1. See diagram.
2. You should use 8 teaspoons of vanilla.
3. You should use 15 cups of flour.

Student Lesson Summary

You can use a **double number line diagram** to find many equivalent ratios. For example, a recipe for fizzy juice says, "Mix 5 cups of cranberry juice with 2 cups of soda water." The ratio of cranberry juice to soda water is $5 : 2$. Multiplying both ingredients by the same number creates equivalent ratios.

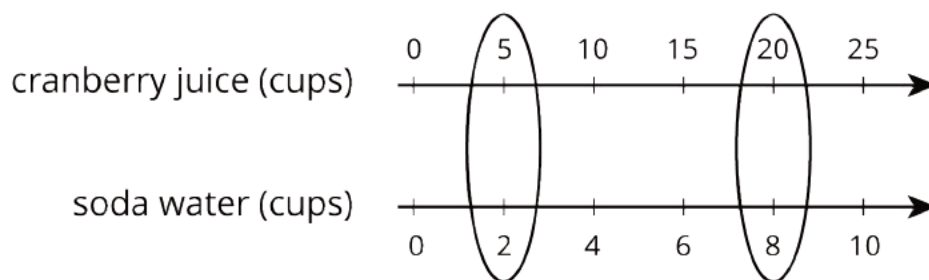

This double number line shows that the ratio $20 : 8$ is equivalent to $5 : 2$. If you mix 20 cups of cranberry juice with 8 cups of soda water, it makes 4 times as much fizzy juice that tastes the same as the original recipe.

Glossary

- double number line diagram

Lesson 6 Practice Problems

Problem 1

Statement

A particular shade of orange paint has 2 cups of yellow paint for every 3 cups of red paint. On the double number line, circle the numbers of cups of yellow and red paint needed for 3 batches of orange paint.

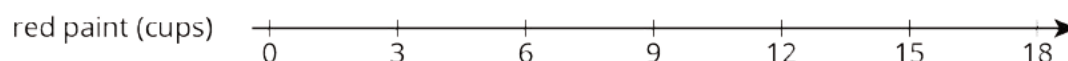
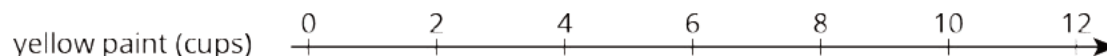

Solution

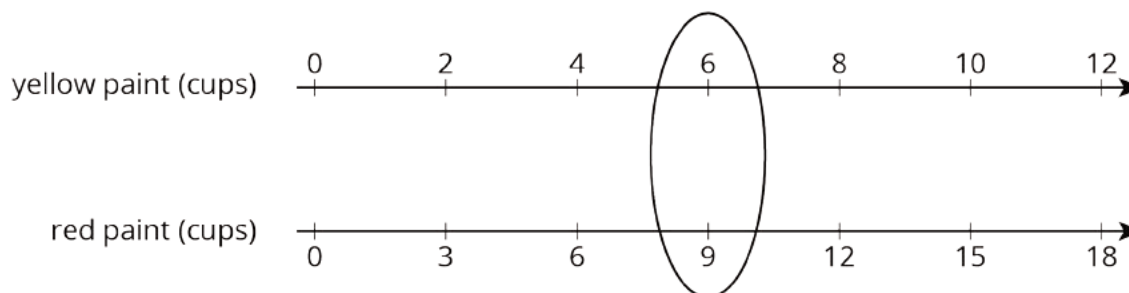

Problem 2

Statement

This double number line diagram shows the amount of flour and eggs needed for 1 batch of cookies.

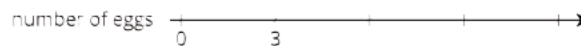

- Complete the diagram to show the amount of flour and eggs needed for 2, 3, and 4 batches of cookies.
 - What is the ratio of cups of flour to eggs?
 - How much flour and how many eggs are used in 4 batches of cookies?
- How much flour is used with 6 eggs?
 - How many eggs are used with 15 cups of flour?

Solution

- a. Flour in cups: 5, 10, 15, 20. Number of eggs: 3, 6, 9, 12.
- b. 5 : 3 or equivalent
- c. 20 cups of flour and 12 eggs
- d. 10 cups
- e. 9 eggs

Problem 3

Statement

Here is a representation showing the amount of red and blue paint that make 2 batches of purple paint.

- a. On the double number line, label the tick marks to represent amounts of red and blue paint used to make batches of this shade of purple paint.

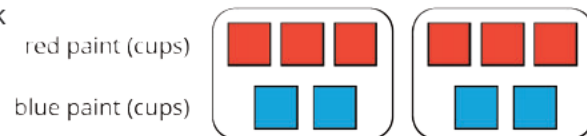

- a. How many batches are made with 12 cups of red paint?



- b. How many batches are made with 6 cups of blue paint?



Solution

- a. Red (cups): 0, 3, 6, 9, 12; Blue (cups): 0, 2, 4, 6, 8
- b. 4 batches
- c. 3 batches

Problem 4

Statement

Diego estimates that there will need to be 3 pizzas for every 7 kids at his party. Select **all** the statements that express this ratio.

- A. The ratio of kids to pizzas is 7 : 3.
- B. The ratio of pizzas to kids is 3 to 7.
- C. The ratio of kids to pizzas is 3 : 7.
- D. The ratio of pizzas to kids is 7 to 3.
- E. For every 7 kids there need to be 3 pizzas.

Solution

["A", "B", "E"]

(From Unit 2, Lesson 1.)

Problem 5

Statement

- a. Draw a parallelogram that is not a rectangle that has an area of 24 square units. Explain or show how you know the area is 24 square units.

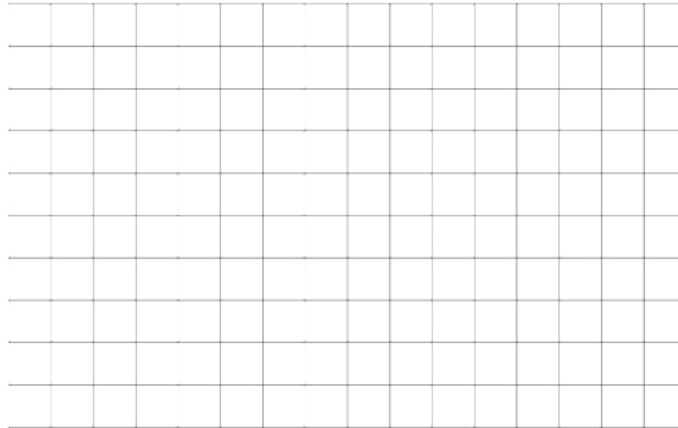

- b. Draw a triangle that has an area of 24 square units. Explain or show how you know the area is 24 square units.



Solution

Answers vary. There are many possible pairs of base and height lengths to make an area of 24 square units.

(From Unit 1, Lesson 6.)

Lesson 7: Creating Double Number Line Diagrams

Goals

- Comprehend and use the word “per” (orally and in writing) to mean “for each.”
- Draw and label a double number line diagram from scratch, with parallel lines and equally-spaced tick marks.
- Use double number line diagrams to find a wider range of equivalent ratios.

Learning Targets

- I can create a double number line diagram and correctly place and label tick marks to represent equivalent ratios.
- I can explain what the word per means.

Lesson Narrative

In this lesson, students create double number line diagrams from scratch. They see that it is important to use parallel lines, equally-spaced tick marks, and descriptive labels. They are also introduced to using the word **per** to refer to how much of one quantity there is for every one unit of the other quantity.

Double number lines are included in the first few activity statements to help students find an equivalent ratio involving one item or one unit. In later activities and lessons, students make their own strategic choice of an appropriate representation to support their reasoning (MP5). Regardless of method, students indicate the units that go with the numbers in a ratio, in both verbal statements and diagrams.

Note that students are not expected to use or understand the term “unit rate” in this lesson.

Alignments

Building On

- 4.NF: Grade 4 - Number and Operations---Fractions

Addressing

- 6.RP.A.3: Use ratio and rate reasoning to solve real-world and mathematical problems, e.g., by reasoning about tables of equivalent ratios, tape diagrams, double number line diagrams, or equations.

Instructional Routines

- Anticipate, Monitor, Select, Sequence, Connect
- MLR1: Stronger and Clearer Each Time
- MLR7: Compare and Connect

- MLR8: Discussion Supports
- Think Pair Share

Required Materials

Rulers

Required Preparation

It may be helpful—but not required—to bring back the blue and yellow water mixtures.

Student Learning Goals

Let's draw double number line diagrams like a pro.

7.1 Ordering on a Number Line

Warm Up: 10 minutes

In this warm-up, students partition a number line and locate fraction and decimal equivalents in preparation for working with double number lines in this unit. Students are purposely not asked to locate 1 on the number line to see how they reason about locating the $\frac{1}{2}$ and $\frac{1}{4}$. It is important for students to be able to identify the fractions or decimals and label tick marks correctly, interpreting the distance between tick marks, rather than the number of tick marks, as the fractional size. As students discuss with their partner, select students to share their answers to the first question during the whole-class discussion.

Building On

- 4.NF

Instructional Routines

- MLR8: Discussion Supports
- Think Pair Share

Launch

Arrange students in groups of 2. Display the number line for all to see. Give students 2 minutes of quiet think time and ask them to give a signal when they have an answer and a strategy. Ask students to compare their number line with a partner and share the fractions or decimals they chose to place on the number line for the second question.

Support for English Language Learners

Reading, Writing: MLR8 Discussion Supports. Briefly review the meaning of the terms “label” and “tick marks” as you or a student points to these features in the student task statement. Review the meaning of the term “locate” by acting out and thinking aloud.

Design Principle(s): Support sense-making

Anticipated Misconceptions

Students may place $\frac{1}{2}$ in the center of the number line, reasoning that it is half of the number line. Explain to the students they are placing the number $\frac{1}{2}$, which has a specific value and location on the number line.

Student Task Statement

1. Locate and label the following numbers on the number line:

$\frac{1}{2}$ $\frac{1}{4}$ $1\frac{3}{4}$ 1.5 1.75



2. Based on where you placed the numbers, locate and label four more fractions or decimals on the number line.

Student Response

1. Here is the number line:

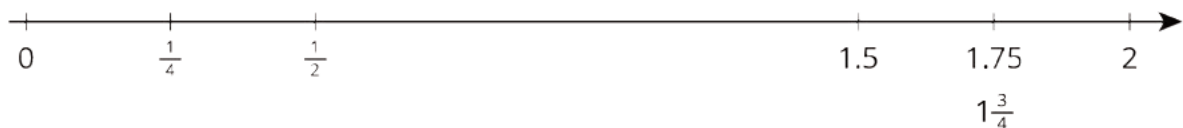

2. Answers vary.

Activity Synthesis

Select students to explain how they reasoned about the location of each number on the number line. After each number, ask the class whether they agree or disagree, and if anyone else had a different way of thinking about that number. If time permits, ask students to share the fractions or decimals they located for the second question. Discuss why they chose those numbers and how they decided on their location.

7.2 Just a Little Green

10 minutes

Students continue to use double number lines to reason about equivalent ratios. Here students' attention is directed to the 1 : 3 blue-to-yellow ratio in the green water recipe, which can then be used to determine any equivalent ratio. The task is also the beginning of students' exploration of finding and using ratios containing a 1.

One key idea to convey here is that finding a ratio associated with 1 unit of a quantity can be very helpful. Another is that the intervals on double number lines can be subdivided to help us find such ratios.

As students work, identify those who use division to determine the 1 : 3 ratio, and then use multiplication to determine the ratios for 8 ml and 13 ml of blue water. This is a key insight for a type of reasoning that is broadly useful and will be developed further.

Addressing

- 6.RP.A.3

Instructional Routines

- MLR1: Stronger and Clearer Each Time
- Think Pair Share

Launch

Ask students to recall what double number lines are and how they can be used to represent problems involving equivalent ratios. Explain that they are going to investigate the structure of double number lines in more detail. Give students 5 minutes of quiet think time, and then time to discuss their responses with a partner.

Support for Students with Disabilities

Representation: Internalize Comprehension. Represent the same information through different modalities by using physical objects to represent abstract concepts. Some students may benefit by starting with a kinesthetic representation of the number line on a clothesline. Students can place and adjust numbers on folded paper or cardstock on the clothesline.
Supports accessibility for: Conceptual processing; Visual-spatial processing

Support for English Language Learners

Writing, Conversing: MLR1 Stronger and Clearer Each Time. Use this routine to help students optimize for generalization related to the importance of “for every 1 ml”, by providing them with multiple opportunities to clarify their explanations through conversation. Give students time to meet with 2–3 partners to share their response to the question, “Why is it useful to know how much yellow water should be used with 1 ml of blue water?” Provide listeners with prompts for feedback that will help their partner add detail to strengthen and clarify their ideas. For example, students can ask their partner, “How did you use double number lines to solve this problem?” or “Can you say more about what the ratio means in this context?” Next, provide students with 3–4 minutes to revise their initial draft based on feedback from their peers. This will help students produce a written generalization that explains the importance of finding and using ratios containing a 1.

Design Principle(s): Optimize output (for generalization)

Anticipated Misconceptions

Students may have trouble figuring out that the length of a segment between consecutive tick marks is $\frac{1}{5}$ of the interval from 0 to 5, especially since there are four tick marks (not five). When focusing on blue, students’ first guess about the tick marks is generally correct. For yellow, remind them that the numbers on the tick marks are made by skip counting; they are then likely to try 3’s and 5’s since both can make 15. Students who label the spaces between tick marks rather than the tick marks themselves may need additional work with important measurement conventions.

Student Task Statement

The other day, we made green water by mixing 5 ml of blue water with 15 ml of yellow water. We want to make a very small batch of the same shade of green water. We need to know how much yellow water to mix with only 1 ml of blue water.

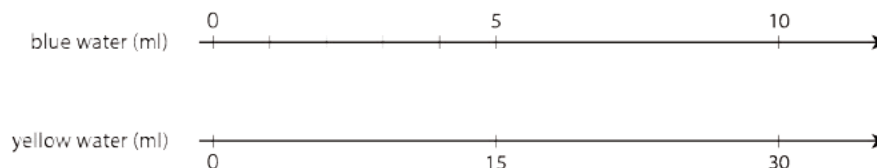

1. On the number line for blue water, label the four tick marks shown.
2. On the number line for yellow water, draw and label tick marks to show the amount of yellow water needed for each amount of blue water.
3. How much yellow water should be used for 1 ml of blue water? Circle where you can see this on the double number line.
4. How much yellow water should be used for 11 ml of blue water?

5. How much yellow water should be used for 8 ml of blue water?
6. Why is it useful to know how much yellow water should be used with 1 ml of blue water?

Student Response

1. Write 1, 2, 3, 4 at the tick marks, because the fifth tick mark is 5.
2. Write 3, 6, 9, 12 at the tick marks, because the fifth tick mark is 15.
3. 3 ml of yellow water is needed.
4. 33 ml of yellow water is needed, because $33 = 3 \cdot 11$.
5. 24 ml of yellow water is needed, because $24 = 3 \cdot 8$.
6. Using this, you can multiply to figure out any amount of yellow water needed for a given amount of blue water.

Activity Synthesis

Debrief as a class after students have a chance to share their work with a partner. Focus discussions on how students determine the amount of yellow water for 1 ml of blue, and how they determine the amounts of yellow for 8 ml and 11 ml of blue. Select students who used division (to find the former) and multiplication (to find the latter) to share.

If students do not do so, frame the relationship of blue to yellow using phrases such as “for every 1 ml of . . .” or “per milliliter of . . .”

- “There are 3 milliliters of yellow water for every 1 milliliter of blue water.”
- “There are 3 milliliters of yellow water **per** milliliter of blue water.”

The word **per** means “for every.” Ask students to think of any other situation in which they may use the word “per” as it is used here (e.g., price per bottle of water, cost per ticket, etc.) and discuss why knowing the value of one item would be helpful.

7.3 Art Paste on a Double Number Line

20 minutes

In the previous lesson, students were given blank double number line diagrams and were only responsible for labeling them to match the situation. In this activity, students draw their own double number line diagram from scratch and identify which elements are important to create a useful double number line diagram.

Addressing

- 6.RP.A.3

Instructional Routines

- MLR8: Discussion Supports

Launch

"You just used a double number line to solve some problems. Now, you'll create a double number line from scratch. Once you know how to make double number lines, you can use them for any situation with equivalent ratios."

Arrange students in groups of 2. Ensure each student has access to a ruler. Have students check with a partner and come to an agreement about how to draw the diagrams before moving on to question 3.

Support for English Language Learners

Representing: MLR8 Discussion Supports. During the launch take time to review the following terms from previous lessons that students will need to access for this activity: double number line, parallel lines, tick marks, equal increments, equivalent ratios and "line up." Use visuals to support understanding of these terms in the context of this problem.

Design Principle(s): Support sense-making

Anticipated Misconceptions

Students may not label tick marks with equal increments or may not align the tick marks.

Student Task Statement

A recipe for art paste says "For every 2 pints of water, mix in 8 cups of flour."

1. Follow the instructions to draw a double number line diagram representing the recipe for art paste.
 - a. Use a ruler to draw two parallel lines.
 - b. Label the first line "pints of water." Label the second line "cups of flour."
 - c. Draw at least 6 equally spaced tick marks that line up on both lines.
 - d. Along the water line, label the tick marks with the amount of water in 0, 1, 2, 3, 4, and 5 batches of art paste.
 - e. Along the flour line, label the tick marks with the amount of flour in 0, 1, 2, 3, 4, and 5 batches of art paste.
2. Compare your double number line diagram with your partner's. Discuss your thinking. If needed, revise your diagram.
3. Next, use your double number line to answer these questions:
 - a. How much flour should be used with 10 pints of water?
 - b. How much water should be used with 24 cups of flour?

c. How much flour **per** pint of water does this recipe use?

Student Response

1. The correctly drawn and labeled number line should look like the one below. The places to find answers to the following questions are circled.

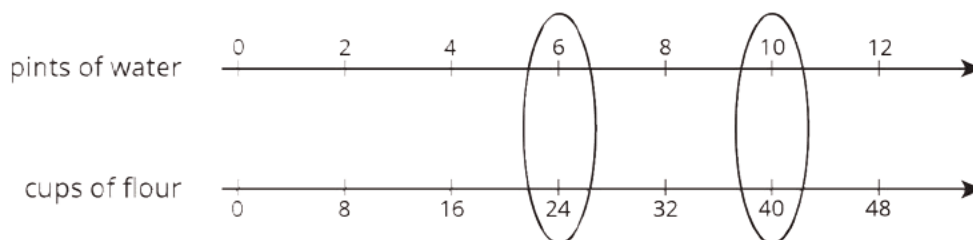

2. No answer necessary.
3. a. Use 40 cups of flour for 10 pints of water.
b. Use 6 pints of water for 24 cups of flour.
c. 4 cups of flour per pint of water

Are You Ready for More?

A square with side of 10 units overlaps a square with side of 8 units in such a way that its corner **B** is placed exactly at the center of the smaller square. As a result of the overlapping, the two sides of the large square intersect the two sides of the small square exactly at points **C** and **E**, as shown. The length of **CD** is 6 units.

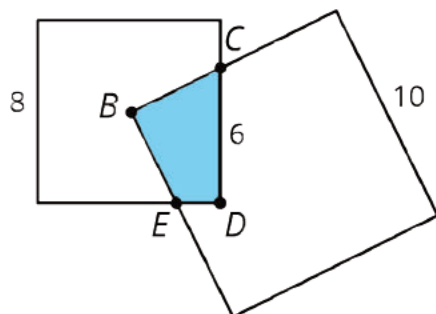

What is the area of the overlapping region **CDEB**?

Student Response

16 square units. Sample reasoning: If you extend **BC** and **BE**, the smaller square is partitioned into four regions of equal area. (A rigorous argument can be made using symmetry, or side lengths and angles, for why these four regions are congruent, but at this stage of learning, students could simply reason that these appear to be four identical copies.) Since the area of the smaller square is 64 square units, the area of the shaded region is 16 square units, because $64 \div 4 = 16$.

Activity Synthesis

Select students to explain how they used their double number line diagram to answer the last question. Ask students how they can indicate the number of cups of flour per pint of water on the double number line.

If desired, capitalize on ways students might have incorrectly constructed their double number line. For example:

- Do all increments on each line need to be equal? Why or why not?
- Do the tick marks on the top line need to match those on the bottom line? Why/why not?
- Does it matter what number we use to start each line? Why or why not?

7.4 Revisiting Tuna Casserole

Optional: 10 minutes

In this activity, students revisit familiar contexts they represented with discrete diagrams in previous lessons. Here, they see how double number line diagrams are helpful for answering more questions about these situations.

Monitor for students who use a discrete diagram and for students who use a double number line diagram.

Addressing

- 6.RP.A.3

Instructional Routines

- Anticipate, Monitor, Select, Sequence, Connect
- MLR7: Compare and Connect

Launch

Arrange students in groups of 2.

Student Task Statement

The other day, we looked at a recipe for tuna casserole that called for 10 ounces of cream of chicken soup for every 3 cups of elbow-shaped pasta.

1. Draw a double number line diagram that represents the amounts of soup and pasta in different-sized batches of this recipe.
2. If you made a large amount of tuna casserole by mixing 40 ounces of soup with 15 cups of pasta, would it taste the same as the original recipe? Explain or show your reasoning.

- The original recipe called for 6 ounces of tuna for every 3 cups of pasta. Add a line to your diagram to represent the amount of tuna in different batches of casserole.
- How many ounces of soup should you mix with 30 ounces of tuna to make a casserole that tastes the same as the original recipe?

Student Response

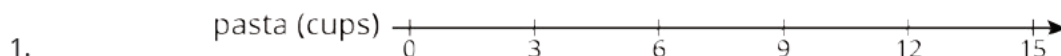
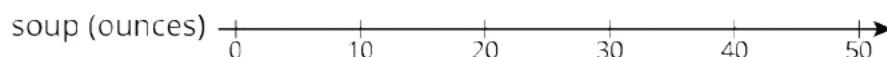

- No, it would not taste the same. Explanations vary. Sample responses:
 - If you want to use 40 ounces of soup, then you should use 12 cups of pasta, because 12 is directly below the 40 on the double number line.
 - If you want to use 15 cups of pasta, then you should use 50 ounces of soup, because 50 is directly above the 15 on the double number line.

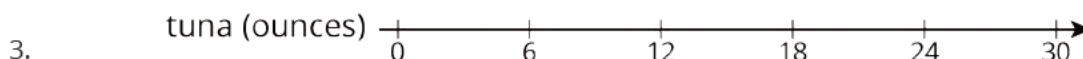
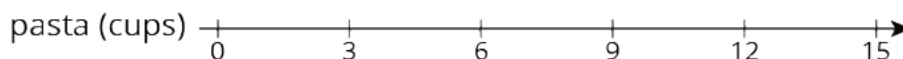
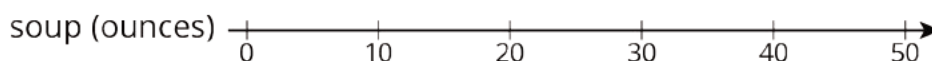

- 50 ounces of soup, because the 50 on the top line of the diagram lines up with the 30 on the bottom line of the diagram.

Activity Synthesis

Select students to present their solutions. Sequence discrete diagrams first and double number line diagrams second. Help students see connections between the two representations.

Support for English Language Learners

Conversing, Representing: MLR7 Compare and Connect. Use this routine to support student understanding of the connections between discrete diagrams and double number line diagrams. After students have presented their solutions, give students quiet think time to consider what is the same and what is different about the two types of representations. Next, ask students to discuss what they noticed with a partner. Listen for and amplify mathematical language students use to describe the connections they notice about how each representation shows equivalent ratios.

Design Principle(s): Maximize meta-awareness

Lesson Synthesis

Create a double number line with the help of the class. Start by asking, "What are some important things to pay attention to when you create a double number line?" Then, "What situation should we represent?" It is fine to choose a situation that students have already encountered in this lesson or an earlier lesson.

As you are creating the double number line together, write down anything mentioned that it is important to pay attention to. For example:

- The two lines you draw should be parallel to each other. One practice is to use both edges of a ruler to create two parallel lines. But double number lines are tools for reasoning, so they don't have to be perfect.
- Each line should be labeled with what it represents. Include units of measure.
- Tick marks should be evenly spaced, and the two sets of tick marks should be lined up vertically in pairs.

One strategy might be to intentionally do something wrong, and ask students how you should fix it. For example, draw tick marks that are very obviously *not* evenly spaced, or neglect to include units of measure in your labels.

7.5 Revisiting Paws, Ears, and Tails

Cool Down: 5 minutes

Addressing

- 6.RP.A.3

Student Task Statement

Each of these cats has 2 ears, 4 paws, and 1 tail.



1. Draw a double number line diagram that represents a ratio in the situation.
2. Write a sentence that describes this situation and that uses the word *per*.

Student Response

1. Students may draw any 2 of the 3 number lines shown.

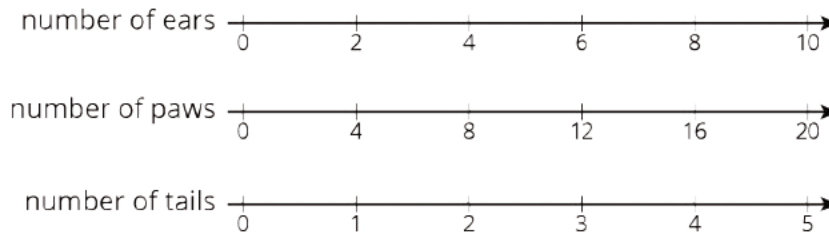

2. Answers vary. Samples responses:

- There are 2 ears per tail.
- There are 4 paws per tail.
- There are 2 paws per ear.
- There is $\frac{1}{2}$ tail per ear.

Student Lesson Summary

Here are some guidelines to keep in mind when drawing a double number line diagram:

- The two parallel lines should have labels that describe what the numbers represent.
- The tick marks and numbers should be spaced at equal intervals.
- Numbers that line up vertically make equivalent ratios.

For example, the ratio of the number of eggs to cups of milk in a recipe is 4 : 1. Here is a double number line that represents the situation:

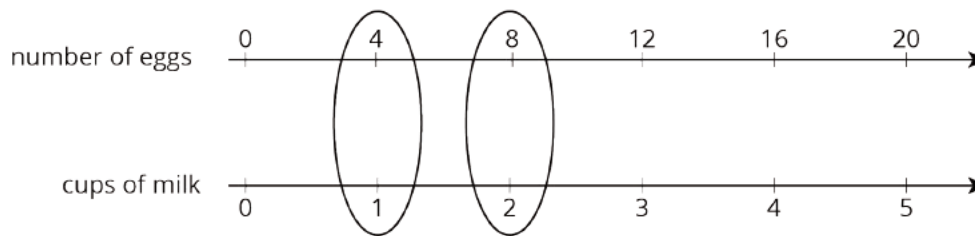

We can also say that this recipe uses “4 eggs per cup of milk” because the word **per** means “for each.”

Glossary

- per

Lesson 7 Practice Problems

Problem 1

Statement

A recipe for cinnamon rolls uses 2 tablespoons of sugar per teaspoon of cinnamon for the filling. Complete the double number line diagram to show the amount of cinnamon and sugar in 3, 4, and 5 batches.



Solution



Problem 2

Statement

One batch of meatloaf contains 2 pounds of beef and $\frac{1}{2}$ cup of bread crumbs. Complete the double number line diagram to show the amounts of beef and bread crumbs needed for 1, 2, 3, and 4 batches of meatloaf.

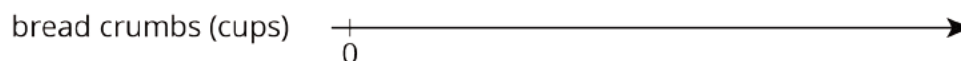

Solution

1 batch: 2 pounds of beef, $\frac{1}{2}$ cup of bread crumbs. 2 batches: 4 pounds of beef, 1 cup of bread crumbs. 3 batches: 6 pounds of beef, $1\frac{1}{2}$ cups of bread crumbs. On a double number line, the top line is labeled 2, 4, 6, 8 and the bottom line is labeled $\frac{1}{2}$, 1, $1\frac{1}{2}$, 2.

Problem 3

Statement

A recipe for tropical fruit punch says, "Combine 4 cups of pineapple juice with 5 cups of orange juice."

- Create a double number showing the amount of each type of juice in 1, 2, 3, 4, and 5 batches of the recipe.
- If 12 cups of pineapple juice are used with 20 cups of orange juice, will the recipe taste the same? Explain your reasoning.
- The recipe also calls for $\frac{1}{3}$ cup of lime juice for every 5 cups of orange juice. Add a line to your diagram to represent the amount of lime juice in different batches of tropical fruit punch.

Solution

- Answers vary. A correct double number line will have equally spaced tick marks. A line labeled "cups of pineapple juice" is labeled 0, 4, 8, 12, 16, 20 and a line labeled "cups of orange juice" is labeled 0, 5, 10, 15, 20, 25.
- No, it will not taste the same. 12 cups of pineapple juice should be mixed with 15 cups of orange juice.
- A line labeled "cups of lime juice" is labeled $\frac{1}{3}$, $\frac{2}{3}$, 1, $1\frac{1}{3}$, $1\frac{2}{3}$.

Problem 4

Statement

One batch of pink paint uses 2 cups of red paint and 7 cups of white paint. Mai made a large amount of pink paint using 14 cups of red paint.

- How many batches of pink paint did she make?
- How many cups of white paint did she use?

Solution

- 7 batches (because 14 is $7 \cdot 2$)
- 49 cups (because $7 \cdot 7 = 49$)

(From Unit 2, Lesson 4.)

Problem 5

Statement

- Find three different ratios that are equivalent to the ratio 3 : 11.
- Explain why your ratios are equivalent.

Solution

- Answers vary. Sample response: 6 : 22, 9 : 33, 12 : 44.
- Answers vary. Sample response: These ratios come from 3 : 11 by multiplying both numbers in the ratio by 2, 3, and 4 respectively.

(From Unit 2, Lesson 5.)

Problem 6

Statement

Here is a diagram that represents the pints of red and yellow paint in a mixture.

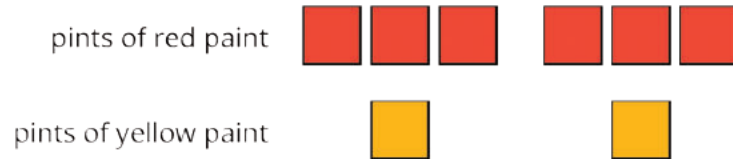

Select **all** statements that accurately describe the diagram.

- The ratio of yellow paint to red paint is 2 to 6.
- For every 3 pints of red paint, there is 1 pint of yellow paint.
- For every pint of yellow paint, there are 3 pints of red paint.
- For every pint of yellow paint there are 6 pints of red paint.
- The ratio of red paint to yellow paint is 6 : 2.

Solution

["A", "B", "C", "E"]

(From Unit 2, Lesson 2.)

Lesson 8: How Much for One?

Goals

- Calculate equivalent ratios between prices and quantities and present the solution method (using words and other representations).
- Calculate unit price and express it using the word “per” (orally and in writing).
- Understand the phrase “at this rate” indicates that equivalent ratios are involved.

Learning Targets

- I can choose and create diagrams to help me reason about prices.
- I can explain what the phrase “at this rate” means, using prices as an example.
- If I know the price of multiple things, I can find the price per thing.

Lesson Narrative

This lesson introduces students to the idea of **unit price**. Students use the word “per” to refer to the cost of one apple, one pound, one bottle, one ounce, etc., as in “\$6 per pound” or “\$1.50 per avocado.” The phrase “at this rate” is used to indicate that the ratios of price to quantity are equivalent. (For example, “Pizza costs \$1.25 per slice. At this rate, how much for 6 slices?”) They find unit prices in different situations, and notice that unit prices are useful in computing prices for other amounts (MP7).

Students choose whether to draw double number lines or other representations to support their reasoning. They continue to use precision in stating the units that go with the numbers in a ratio in both verbal statements and diagrams (MP6).

Note that students are not expected to use or understand the term “unit rate” in this lesson.

Alignments

Building On

- 4.NBT: Grade 4 - Number and Operations in Base Ten

Addressing

- 6.RP.A.3.b: Solve unit rate problems including those involving unit pricing and constant speed. For example, if it took 7 hours to mow 4 lawns, then at that rate, how many lawns could be mowed in 35 hours? At what rate were lawns being mowed?

Instructional Routines

- Anticipate, Monitor, Select, Sequence, Connect
- Group Presentations

- MLR5: Co-Craft Questions
- MLR8: Discussion Supports
- Number Talk
- Think Pair Share

Required Materials

Rulers

paper and markers, whiteboard space and

Tools for creating a visual display

markers, shared online drawing tool, access to a document camera.

Any way for students to create work that can be easily displayed to the class. Examples: chart

Student Learning Goals

Let's use ratios to describe how much things cost.

8.1 Number Talk: Remainders in Division

Warm Up: 10 minutes

This number talk encourages students to think about the numbers in a computation problem and rely on what they know about structure, patterns, and division with remainders to mentally solve a problem.

Only one problem is presented to allow students to share a variety of strategies for division. Notice how students handle a remainder in a problem, which may depend on their prior experiences with division. Students may write it as "r_" and struggle with either fraction or decimal notation. In the next lesson, when students begin finding unit price, they will need to be able to interpret the remainder in either decimal or fraction form.

Building On

- 4.NBT

Instructional Routines

- MLR8: Discussion Supports
- Number Talk

Launch

Display the problem for all to see. Give students 2 minutes of quiet think time and ask them to give a signal when they have an answer and a strategy. Follow with a whole-class discussion.

Support for Students with Disabilities

Representation: Internalize Comprehension. To support working memory, provide students with sticky notes or mini whiteboards.

Supports accessibility for: Memory; Organization

Anticipated Misconceptions

Students may struggle to interpret the remainder as a decimal or fraction and may instead write $r 6$.

Student Task Statement

Find the quotient mentally.

$$246 \div 12$$

Student Response

- $246 \div 12 = 20.5$ or $246 \div 12 = 20\frac{1}{2}$

Possible strategies:

- Multiplying up: $(12 \cdot 20) + (12 \cdot \frac{1}{2})$
- Partial quotients: $(240 \div 12) + (6 \div 12)$

Activity Synthesis

Invite students to share their strategies. Record and display student explanations for all to see. Ask students to explain if or how the dividend or divisor impacted their choice of strategy and how they decided to write their remainder. To involve more students in the conversation, consider asking:

- "Who can restate ___'s reasoning in a different way?"
- "Did anyone solve the problem the same way but would explain it differently?"
- "Did anyone solve the problem in a different way?"
- "Does anyone want to add on to ____'s strategy?"
- "Do you agree or disagree? Why?"

At the end of discussion, if time permits, ask a few students to share a story problem or context that $246 \div 12 = 20.5$ would represent.

Support for English Language Learners

Speaking: MLR8 Discussion Supports.: Display sentence frames to support students when they explain their strategy. For example, "First, I ____ because . . ." or "I noticed ____ so I" Some students may benefit from the opportunity to rehearse what they will say with a partner before they share with the whole class.

Design Principle(s): Optimize output (for explanation)

8.2 Grocery Shopping

10 minutes (there is a digital version of this activity)

This activity continues the work on ratios involving one unit of something. Students determine the prices of grocery items and learn to use the term **unit price** to describe cost per unit. To determine unit prices, students may:

- Divide the cost by the number of items
- Use discrete diagrams
- Use a double number line

As students work, monitor for students using different methods.

If students choose to draw a double number line diagram, remind them to label each number line and to circle the ratio where they find the answer.

Addressing

- 6.RP.A.3.b

Instructional Routines

- Anticipate, Monitor, Select, Sequence, Connect
- MLR5: Co-Craft Questions
- Think Pair Share

Launch

Frame the task in shopping terms. Say that when most of us go shopping, we often see prices for multiple items or units (e.g., 2 bottles for \$3, or \$1.99 for three pounds, etc.). But sometimes we want to know how much it costs to buy just one item or one unit of something. Tell students they will explore the use of “per” in the context of shopping. Ask students to solve the problems involving “price for one” using any method, and to be ready to explain their reasoning. Provide access to rulers in case students choose to draw double number lines. Give students a few minutes of quiet

think time. Pause after the first question, and if any students say the answer is 2, point out that is avocados per dollar rather than dollars per avocado.

If students have digital access, they can use an applet to explore the problem and justify their reasoning before discussing with a partner. Allow students 1–2 minutes of work time and then demonstrate how to use the applet with the first problem.

Support for Students with Disabilities

Representation: Internalize Comprehension. Activate background knowledge about finding unit prices. Allow students to use calculators to ensure inclusive participation in the activity.

Supports accessibility for: Memory; Conceptual processing

Support for English Language Learners

Writing and Conversing: Math Language Routine 5 Co-Craft Questions. This is the first time Math Language Routine 5 is suggested as a support in this course. In this routine, students are given a context or situation, often in the form of a problem stem with or without numerical values. Students develop mathematical questions that can be asked about the situation. A typical prompt is: "What mathematical questions could you ask about this situation?" The purpose of this routine is to allow students to make sense of a context before feeling pressure to produce answers, and to develop students' awareness of the language used in mathematics problems.
Design Principle(s): Maximize meta-awareness

How It Happens:

1. After students complete the first question, bring the class together and present only the stem:

Twelve large bottles of water cost \$9.

Do not allow students to see the follow-up questions for this situation.

Ask students, "What mathematical questions could you ask about this situation?"

2. Give students 1 minute of individual time to jot some notes, and then 3 minutes to share ideas with a partner.

As pairs discuss, support students in using conversation skills to generate and refine their questions collaboratively by seeking clarity, referring to students' written notes, and revoicing oral responses as necessary. Listen for students' use of 'per' as they talk.

If using the applet, have pairs use the applet together. Check that students correctly identify and enter the quantities (water bottles and dollars) so their sense-making with the tick marks is grounded in a clear enough interpretation of the situation.

3. Ask each pair of students to contribute one written question to a poster, the whiteboard, or digital projection. Call on 2–3 pairs of students to present their question to the whole class, and invite the class to make comparisons among the questions shared and their own questions.

Listen for questions intended to ask about the unit price for a single water bottle, and listen for their use of 'per'. Revoice student ideas with an emphasis on the use of 'per' wherever it serves to clarify a question.

4. Reveal the follow-up questions for this situation and give students a couple of minutes to compare these three questions to their own and those of their classmates. Identify similarities and differences.

-
- How many bottles can you buy for \$3?
 - What is the cost per bottle of water?
 - How much would 7 bottles of water cost?

5. Invite students to choose one question to answer (from the class or from the curriculum), and then have students move on to the following problems.

Anticipated Misconceptions

Some students may have difficulty with the answers not being integers. Either fractions or decimals are acceptable. Fractions provide the most direct route, but decimals are common for working with dollars and cents. Also, students may use the larger numbers as the dividend, simply because they are larger. Encourage students to check the reasonableness of their answers.

Student Task Statement

Answer each question and explain or show your reasoning. If you get stuck, consider drawing a double number line diagram.

1. Eight avocados cost \$4.

- a. How much do 16 avocados cost?
- b. How much do 20 avocados cost?
- c. How much do 9 avocados cost?



2. Twelve large bottles of water cost \$9.

- a. How many bottles can you buy for \$3?
- b. What is the cost per bottle of water?
- c. How much would 7 bottles of water cost?



3. A 10-pound sack of flour costs \$8.

- a. How much does 40 pounds of flour cost?

b. What is the cost per pound of flour?

Student Response

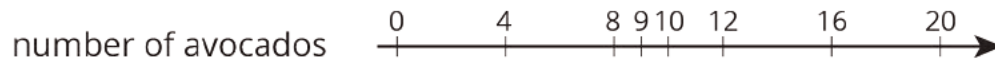

- 16 avocados cost \$8, because $4 \cdot 2 = 8$ and $8 \cdot 2 = 16$.
 - 20 avocados cost \$10.
 - 9 avocados cost \$4.50.

2.

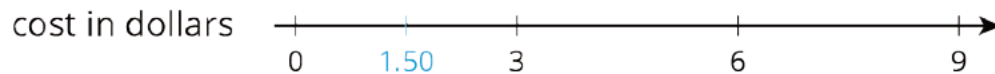

- You can buy 4 bottles for \$3, because $9 \cdot \frac{1}{3} = 3$ and $12 \cdot \frac{1}{3} = 4$.
 - The cost per bottle is \$0.75, because $9 \div 12 = 0.75$.
 - The cost for 7 bottles is \$5.25, because $(0.75) \cdot 7 = 5.25$.
- 40 pounds costs \$32, because $10 \cdot 4 = 40$ and $8 \cdot 4 = 32$.
 - The cost per pound is \$0.80, because $8 \div 10 = 0.8$.

Are You Ready for More?

It is commonly thought that buying larger packages or containers, sometimes called *buying in bulk*, is a great way to save money. For example, a 6-pack of soda might cost \$3 while a 12-pack of the same brand costs \$5.

Find 3 different cases where it is not true that buying in bulk saves money. You may use the internet or go to a local grocery store and take photographs of the cases you find. Make sure the products are the same brand. For each example that you find, give the quantity or size of each, and describe how you know that the larger size is not a better deal.

Student Response

Answers vary.

Activity Synthesis

Select students who used unique methods to share their reasoning, as listed in the narrative. If no one used double number lines, represent one of the statements with a double number line diagram and display it for all to see. Although double number lines are not required in the task, their use in the context of problem situations helps students see their merits and illustrates how they might be used in other problems, especially as students transition from unit prices to constant speed and other contexts. Draw connections between the double number line strategy and the dividing by the numbers of items strategy.

Tell students that each “cost per one” unit being sold—avocado, pound, or bottle—is an example of a **unit price**. Ask them to name as many kinds of unit prices they can and to think of a situation where they might be used, starting with the list from the task:

- Cost per avocado
- Cost per pound
- Cost per bottle

Other possibilities include cost per liter, cost per ounce, cost per jelly bean, and so on.

8.3 More Shopping

15 minutes (there is a digital version of this activity)

In this task, students practice finding unit prices, using different reasoning strategies, and articulating their reasoning. They also learn about the term “at this rate.”

As students work, observe their work and then assign one problem for each group to own and present to the class. (The problems can each be assigned to more than one group). Have them work together to create a visual display of their problem and its solution.

Addressing

- 6.RP.A.3.b

Instructional Routines

- Group Presentations

Launch

Arrange students in groups of 3–4. Provide tools for creating a visual display and access to rulers. Explain that they will work together to solve some shopping problems, run their work by you, and prepare to present an assigned problem to the class. Tell students that they can use double number lines if they wish.

Display the problem and read it aloud: Pizza costs \$1.25 per slice. At this rate, how much will 6 slices cost?

Ask students what they think “at this rate” means in the question. Ensure they understand that “at this rate” means we know that equivalent ratios are involved:

- The ratio of cost to number of slices is \$1.25 to 1. That is, pizza costs \$1.25 per slice.
- The ratio of cost to number of slices is *something* to 6. That is, pizza costs *something* for 6 slices.

The *something* is the thing we are trying to figure out, and “at this rate” tells us that the two ratios in this situation are equivalent. Another way to understand “at this rate” in this context is “at this price per unit” and that the price per unit is the same no matter how many items or units are purchased.

Discuss any expectations for the group presentation. For example, each group member might be assigned a specific role for the presentation.

If students have digital access, they can use an applet to explore the problems and justify their reasoning before preparing their presentations.

Anticipated Misconceptions

The first and third questions involve using decimals to represent cents. If the decimal point is forgotten, remind students that the cost of the bracelet is less than one dollar, and the cost of the chips is in between one and two dollars.

Watch for students working in cents instead of dollars for the bracelets. They may come up with an answer of 275 cents. For these students, writing 25 cents as \$0.25 should help, or consider reminding them of the avocados from a previous activity, which had a unit price of \$0.50.

Student Task Statement

1. Four bags of chips cost \$6.
 - a. What is the cost per bag?
 - b. At this rate, how much will 7 bags of chips cost?
2. At a used book sale, 5 books cost \$15.
 - a. What is the cost per book?
 - b. At this rate, how many books can you buy for \$21?
3. Neon bracelets cost \$1 for 4.
 - a. What is the cost per bracelet?
 - b. At this rate, how much will 11 neon bracelets cost?

Pause here so your teacher can review your work.



4. Your teacher will assign you one of the problems. Create a visual display that shows your solution to the problem. Be prepared to share your solution with the class.

Student Response

1. a. The cost per bag is \$1.50.
b. Seven bags cost \$10.50.
2. a. The cost per book is \$3.
b. You can buy 7 books for \$21.
3. a. The cost per bracelet is 25 cents.
b. Eleven bracelets cost \$2.75.

Activity Synthesis

Invite each group to present its assigned problem. After each group presents, highlight the group's strategy, accurate uses of the terms "at this rate" and "per," and the ways in which a double number line might have been used when working with unit price.

Lesson Synthesis

The main ideas to develop in this lesson are techniques for finding a **unit price**, and the things that can be done once a unit price is known.

Discuss with students the methods they use to find a unit price. The likely answers are:

- Division: if 2 bags of rice cost \$3, then 1 bag costs $3 \div 2 = 1.50$.
- Double number line: adding tick marks to a double number line signifying 1 bag can determine the cost per bag. Briefly discuss with students the meaning of the word *per* (for each).

Discuss with students the things they can do once they know a unit price. Specifically, they can directly compute any cost when the number of items is known by multiplying the unit price by the number of items. You may want to point out to students that by multiplying, they are finding part of an equivalent ratio. For example, the ratio "\$30 for 20 bags" is equivalent to the ratio "\$3 for 2 bags."

8.4 Unit Price of Rice

Cool Down: 5 minutes

Addressing

- 6.RP.A.3.b

Student Task Statement

Here is a double number line showing that it costs \$3 to buy 2 bags of rice:

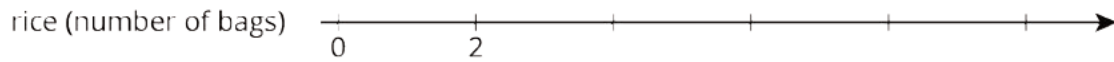
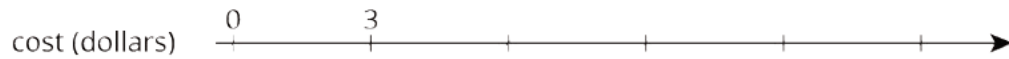

1. At this rate, how many bags of rice can you buy with \$12?
2. Find the cost per bag.
3. How much do 20 bags of rice cost?

Student Response

1. 8 bags cost \$12.
2. The cost per bag is \$1.50.
3. 20 bags cost \$30. Multiply by the price for one bag or use an equivalent ratio.

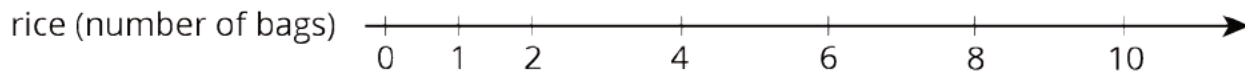
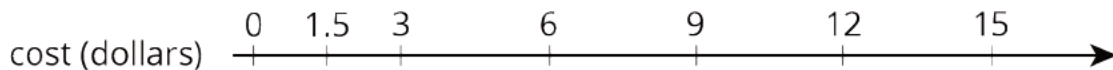

Student Lesson Summary

The **unit price** is the price of 1 thing—for example, the price of 1 ticket, 1 slice of pizza, or 1 kilogram of peaches.

If 4 movie tickets cost \$28, then the unit price would be the cost *per* ticket. We can create a double number line to find the unit price.

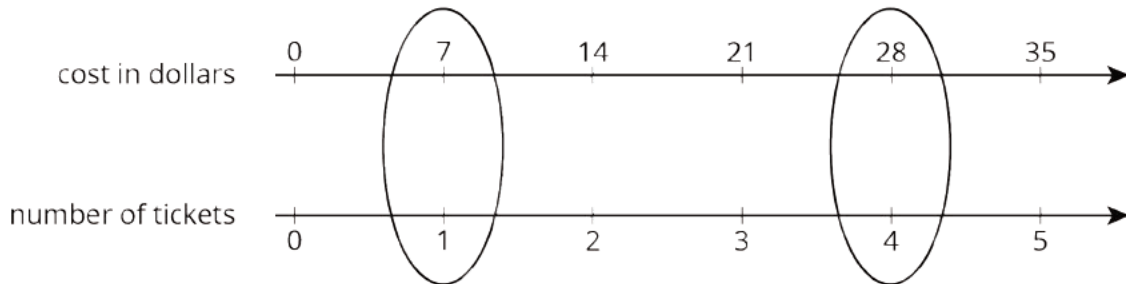

This double number line shows that the cost for 1 ticket is \$7. We can also find the unit price by dividing, $28 \div 4 = 7$, or by multiplying, $28 \cdot \frac{1}{4} = 7$.

Glossary

- unit price

Lesson 8 Practice Problems

Problem 1

Statement

In 2016, the cost of 2 ounces of pure gold was \$2,640. Complete the double number line to show the cost for 1, 3, and 4 ounces of gold.

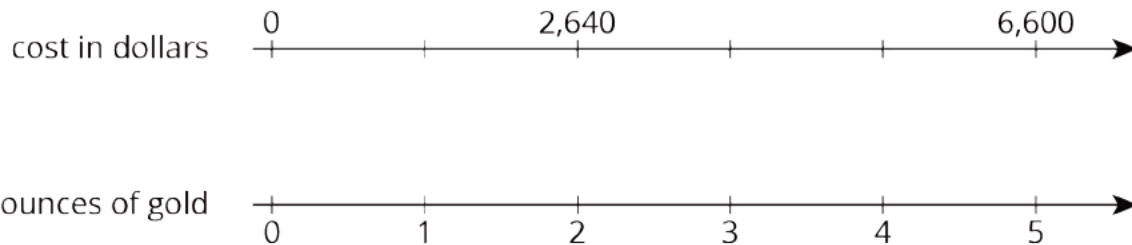

Solution

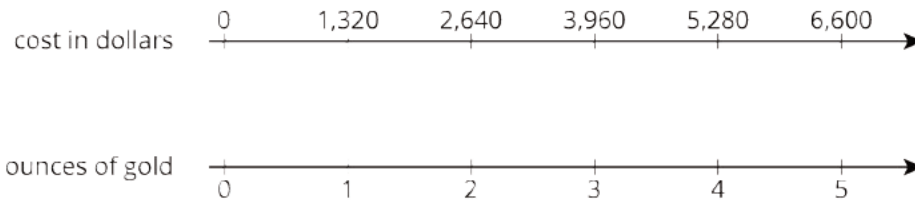

Problem 2

Statement

The double number line shows that 4 pounds of tomatoes cost \$14. Draw tick marks and write labels to show the prices of 1, 2, and 3 pounds of tomatoes.

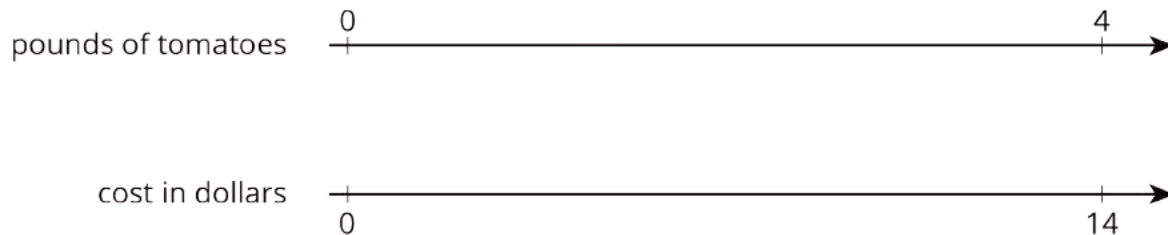

Solution

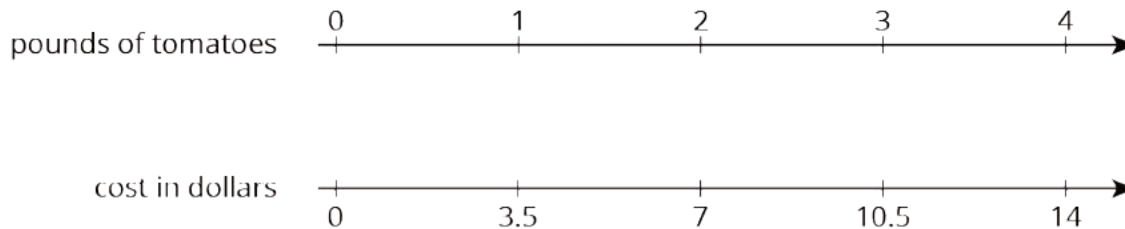

Problem 3

Statement

4 movie tickets cost \$48. At this rate, what is the cost of:

- 5 movie tickets?
- 11 movie tickets?

Solution

- \$60 (1 ticket costs \$12 because $48 \div 4 = 12$. 5 tickets cost \$60 because $5 \cdot 12 = 60$.)
- \$132 (because $11 \cdot 12 = 132$)

Problem 4

Statement

Priya bought these items at the grocery store. Find each unit price.

- 12 eggs for \$3. How much is the cost per egg?
- 3 pounds of peanuts for \$7.50. How much is the cost per pound?
- 4 rolls of toilet paper for \$2. How much is the cost per roll?
- 10 apples for \$3.50. How much is the cost per apple?

Solution

- 25 cents or \$0.25
- \$2.50
- 50 cents or \$0.50
- 35 cents or \$0.35

Problem 5

Statement

Clare made a smoothie with 1 cup of yogurt, 3 tablespoons of peanut butter, 2 teaspoons of chocolate syrup, and 2 cups of crushed ice.

- Kiran tried to double this recipe. He used 2 cups of yogurt, 6 tablespoons of peanut butter, 5 teaspoons of chocolate syrup, and 4 cups of crushed ice. He didn't think it tasted right. Describe how the flavor of Kiran's recipe compares to Clare's recipe.
- How should Kiran change the quantities that he used so that his smoothie tastes just like Clare's?

Solution

- Kiran's smoothie would be more chocolatey than Clare's. All ingredients are doubled, but there is an extra teaspoon of chocolate syrup in his smoothie.
- Answers vary. Sample response: he should use 4 teaspoons of chocolate syrup instead of 5.

(From Unit 2, Lesson 3.)

Problem 6

Statement

A drama club is building a wooden stage in the shape of a trapezoidal prism. The height of the stage is 2 feet. Some measurements of the stage are shown here.

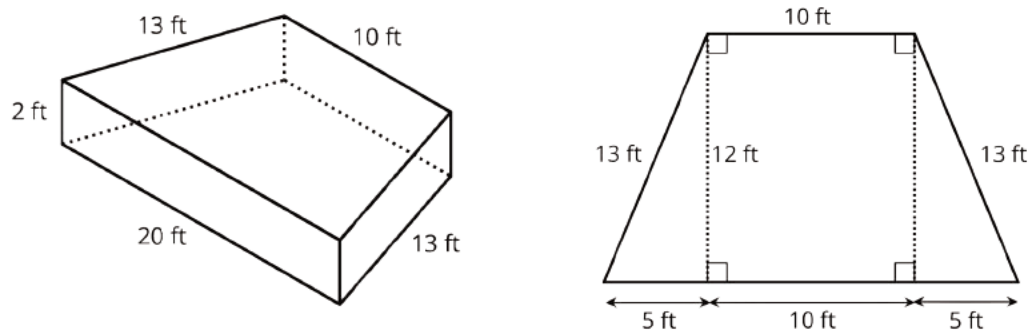

What is the area of all the faces of the stage, excluding the bottom? Show your reasoning. If you get stuck, consider drawing a net of the prism.

Solution

292 square feet. Sample reasoning: The trapezoidal face is 180 square feet since $(12 \cdot 10) + 2\left(\frac{1}{2} \cdot 12 \cdot 5\right) = 120 + 60 = 180$. The side faces are $2(13 \cdot 2) + (10 \cdot 2) + (20 \cdot 2)$ or 112 square feet.

(From Unit 1, Lesson 15.)

Lesson 9: Constant Speed

Goals

- Calculate the distance an object travels in 1 unit of time and express it using a phrase like “meters per second” (orally and in writing).
- For an object moving at a constant speed, use a double number line diagram to represent equivalent ratios between the distance traveled and elapsed time.
- Justify (orally and in writing) which of two objects is moving faster, by identifying that it travels more distance in the same amount of time or that it travels the same distance in less time.

Learning Targets

- I can choose and create diagrams to help me reason about constant speed.
- If I know an object is moving at a constant speed, and I know two of these things: the distance it travels, the amount of time it takes, and its speed, I can find the other thing.

Lesson Narrative

In the previous lesson, students used the context of shopping to explore how equivalent ratios and ratios involving one can be used to find unknown amounts. In this lesson, they revisit these ideas in a new context—constant speed—and through concrete experiences. Students measure the time it takes them to travel a predetermined distance—first by moving slowly, then quickly—and use it to calculate and compare the speed they traveled in **meters per second**.

Here, double number lines are used to represent the association between distance and time, and to convey the idea of constant speed as a set of equivalent ratios (e.g., 10 meters traveled in 20 seconds at a constant speed means that 0.5 meters is traveled in 1 second, and 5 meters is traveled in 10 seconds). Students come to understand that, like price, speed can be described using the terms *per* and *at this rate*.

The idea of a constant speed relating the quantities of distance and time is foundational for the later, more abstract idea of a constant rate, and is important in the development of students’ ability to reason abstractly about quantities (MP2).

Alignments

Building On

- 5.NBT.A.1: Recognize that in a multi-digit number, a digit in one place represents 10 times as much as it represents in the place to its right and $\frac{1}{10}$ of what it represents in the place to its left.

Addressing

- 6.RP.A.3.b: Solve unit rate problems including those involving unit pricing and constant speed. For example, if it took 7 hours to mow 4 lawns, then at that rate, how many lawns could be mowed in 35 hours? At what rate were lawns being mowed?

Instructional Routines

- Anticipate, Monitor, Select, Sequence, Connect
- MLR5: Co-Craft Questions
- MLR7: Compare and Connect
- MLR8: Discussion Supports
- Number Talk
- Think Pair Share

Required Materials

Masking tape
Meter sticks

Stopwatches
String

Required Preparation

Before class, set up 4 paths with a 1-meter warm-up zone and a 10-meter measuring zone.

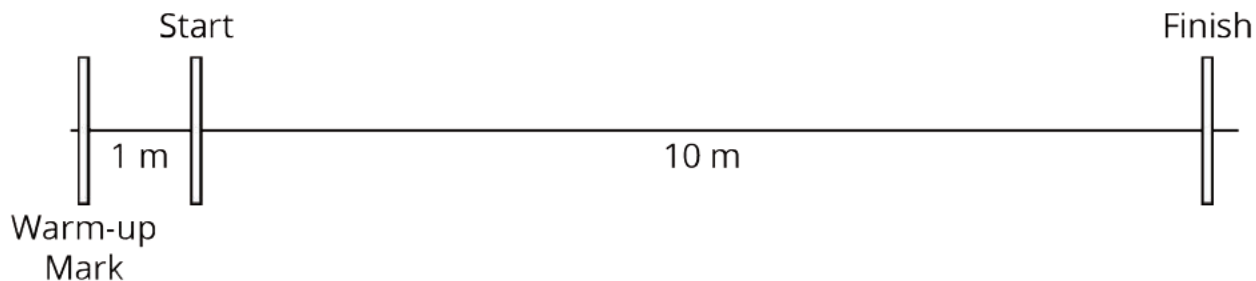

Student Learning Goals

Let's use ratios to work with how fast things move.

9.1 Number Talk: Dividing by Powers of 10

Warm Up: 10 minutes

This number talk encourages students to use the structure of base ten numbers to find the quotient of a base ten number and 10. The goal is to get students to see how understanding each quotient helps them find the next quotient. Reasoning about this computation will be important in both this lesson and future lessons where students are working with the metric system and percentages.

Building On

- 5.NBT.A.1

Instructional Routines

- MLR8: Discussion Supports
- Number Talk

Launch

Display one problem at a time. Give students 1 minute of quiet think time per problem and ask them to give a signal when they have an answer and a strategy. Follow with a whole-class discussion.

Support for Students with Disabilities

Representation: Internalize Comprehension. To support working memory, provide students with sticky notes or mini whiteboards.

Supports accessibility for: Memory; Organization

Student Task Statement

Find the quotient mentally.

$$30 \div 10$$

$$34 \div 10$$

$$3.4 \div 10$$

$$34 \div 100$$

Student Response

- $30 \div 10 = 3$ Possible strategy: $3 \cdot 10 = 30$, or students may say 10 goes into 30 three times.
- $34 \div 10 = 3.4$ Possible strategy: Students may say 10 goes into 34 three times with four tenths (written as a fraction or decimal) left over.
- $3.4 \div 10 = 0.34$ Possible strategy: Using the previous problem, since 34 was divided by 10, students may divide their previous answer by 10. $3.4 \div 10 = 0.34$
- $34 \div 100 = 0.34$ Possible strategy: Students may notice both the dividend and divisor were multiplied by 10 to get this problem, so the quotient is the same.

Activity Synthesis

Ask students to share their strategies for each problem. Record and display their explanations for all to see. Emphasize student strategies based in place value to explain methods students may have learned about “moving the decimal point” left or right or “crossing out zeros.” To involve more students in the conversation, consider asking:

- “Who can restate ___’s reasoning in a different way?”
- “Did anyone solve the problem the same way but would explain it differently?”
- “Did anyone solve the problem in a different way?”
- “Does anyone want to add on to ____’s strategy?”
- “Do you agree or disagree? Why?”

Support for English Language Learners

Speaking: MLR8 Discussion Supports: Display sentence frames to support students when they explain their strategy. For example, “First, I ____ because . . .” or “I noticed ____ so I” Some students may benefit from the opportunity to rehearse what they will say with a partner before they share with the whole class.

Design Principle(s): Optimize output (for explanation)

9.2 Moving 10 Meters

25 minutes

This activity gives students first-hand experience in relating ratios of time and distance to speed. Students time one another as they move 10 meters at a constant speed—first slowly and then quickly—and then reason about the distance traveled in 1 second.

Double number lines play a key role in helping students see how time and distance relate to constant speed, allowing us to compare how quickly two objects are moving in two ways. We can look at how long it takes to move 10 meters (a shorter time needed to move 10 meters means faster movement), or at how far one travels in 1 second (a longer distance in one second means faster movement).

Along the way, students see that the language of “per” and “at this rate,” which was previously used to talk about unit price, is also relevant in the context of constant speed. They begin to use “meters per second” to express measurements of speed.

As students work, notice the different ways they use double number lines or other means to reason about distance traveled in one second.

Addressing

- 6.RP.A.3.b

Instructional Routines

- MLR7: Compare and Connect

Launch

Before class, set up 4 paths with a 1-meter warm-up zone and a 10-meter measuring zone.

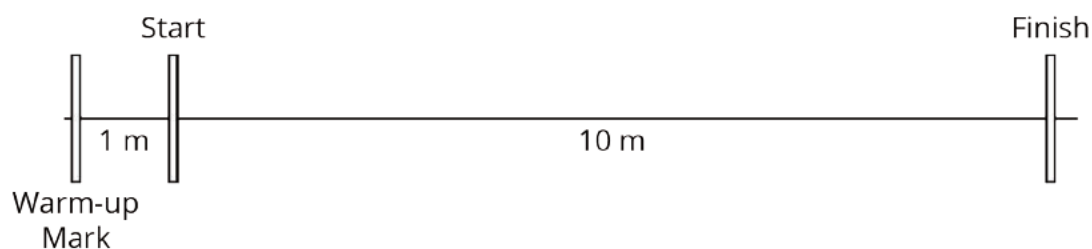

Arrange students into 4 groups, with one for each path. Provide a stopwatch. Explain that they will gather some data on the time it takes to move 10 meters. Select a student to be your partner and demonstrate the activity for the class.

- Share that the experiment involves timing how long it takes to move the distance from the start line to the finish line.
- Explain that each person in the pair will play two roles: “the mover” and “the timer.” Each mover will go twice—once slowly and once quickly—starting at the warm-up mark each time. The initial 1-meter-long stretch is there so the mover can accelerate to a constant speed before the timing begins.
- Demonstrate the timing protocol as shown in the task statement.

Stress the importance of the mover moving at a constant speed while being timed. The warm-up segment is intended to help them reach a steady speed. To encourage students to move slowly, consider asking them to move as if they are balancing something on their head or carrying a full cup of water, trying not to spill it.

Alternatively, set up one path and ask for two student volunteers to demonstrate while the rest of the class watches.

Support for Students with Disabilities

Representation: Internalize Comprehension. Begin with a physical demonstration of the activity. Highlight connections between prior understandings about using number lines to show how time and distance relate to constant speed.

Supports accessibility for: Conceptual processing; Visual-spatial processing

Anticipated Misconceptions

Students may have difficulty estimating the distance traveled in 1 second. Encourage them to mark the double number line to help. For example, marking 5 meters halfway between 0 and 10 and determining the elapsed time as half the recorded total may cue them to use division.

Student Task Statement

Your teacher will set up a straight path with a 1-meter warm-up zone and a 10-meter measuring zone. Follow the following instructions to collect the data.

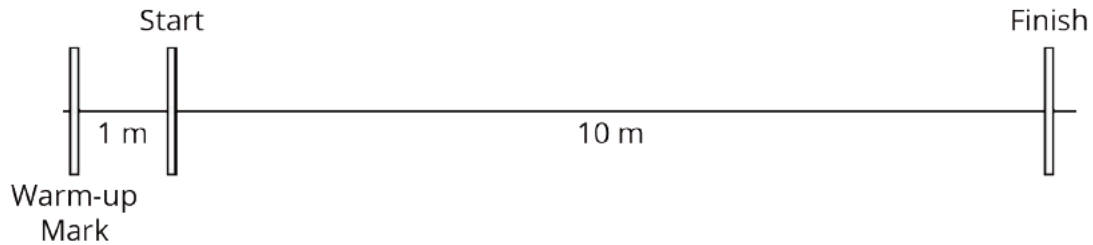

- The person with the stopwatch (the "timer") stands at the finish line. The person being timed (the "mover") stands at the warm-up line.
 - On the first round, the mover starts moving *at a slow, steady speed* along the path. When the mover reaches the start line, they say, "Start!" and the timer starts the stopwatch.
 - The mover keeps moving steadily along the path. When they reach the finish line, the timer stops the stopwatch and records the time, rounded to the nearest second, in the table.
 - On the second round, the mover follows the same instructions, but this time, moving *at a quick, steady speed*. The timer records the time the same way.
 - Repeat these steps until each person in the group has gone twice: once at a slow, steady speed, and once at a quick, steady speed.

your slow moving time (seconds)	your fast moving time (seconds)

- After you finish collecting the data, use the double number line diagrams to answer the questions. Use the times your partner collected while you were moving.

Moving slowly:



Moving quickly:

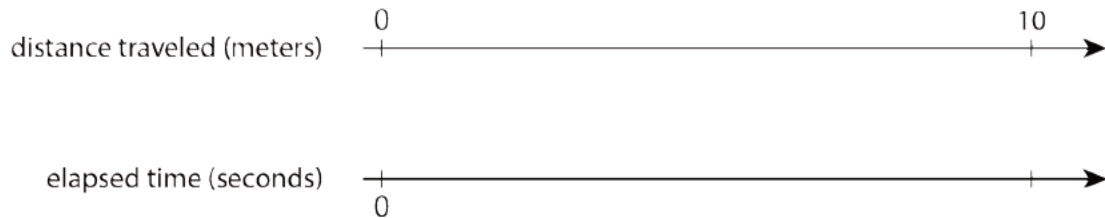

- Estimate the distance in meters you traveled in 1 second when moving slowly.
- Estimate the distance in meters you traveled in 1 second when moving quickly.
- Trade diagrams with someone who is not your partner. How is the diagram representing someone moving slowly different from the diagram representing someone moving quickly?

Student Response

- Diagrams vary.
- Answers vary. Sample response: The diagram that represents moving quickly will have a higher number of meters per second, or a lower number of seconds at 10 meters.

Activity Synthesis

Select students to share who used different methods to reason about the distance traveled in 1 second. It may be helpful to discuss the appropriate amount of precision for their answers. Dividing the distance by the elapsed time can result in a quotient with many decimal places; however, the nature of this activity leads to reporting an approximate answer.

During the discussion, demonstrate the use of the phrase **meters per second** or emphasize it, if it comes up naturally in students' explanations. Discuss how we can use double number lines to distinguish faster movement from slower movement. If it hasn't already surfaced in discussion, help students see we can compare the time it takes to travel the same distance (in this case, 10 meters) as well as the distance traveled in the same amount of time (say, 1 second).

Explain to students that when we represent time and distance on a double number line, we are saying the object is traveling at a constant speed or a constant rate. This means that the ratios of meters traveled to seconds elapsed (or miles traveled to hours elapsed) are equivalent the entire time the object is traveling. The object does not move faster or slower at any time. The equal intervals on the double number line show this steady rate.

Support for English Language Learners

Representing: MLR7 Compare and Connect. As students share different approaches for reasoning about distance traveled in 1 second, ask students to identify "what is the same and what is different?" about the approaches. Help students connect approaches by asking "Where do you see the measurement of speed '___ meters per second' in each approach?" This helps students connect the concept of rate and a visual representation of that rate.

Design Principle(s): Maximize meta-awareness

9.3 Moving for 10 Seconds

10 minutes (there is a digital version of this activity)

In the previous activity, students traveled the same distance in differing amounts of time. In this activity, students analyze a situation where two people travel for the same amount of time, each at a constant speed, but go different distances. The use of double number lines is suggested, but not required.

Monitor students' work and notice different ways students compare speeds. For the first question, students may use meters per second or compare the distance traveled in the same number of seconds. For the last question, they may draw a double number line for each of the scenarios being compared, or calculate each speed in meters per second.

Addressing

- 6.RP.A.3.b

Instructional Routines

- Anticipate, Monitor, Select, Sequence, Connect
- MLR5: Co-Craft Questions
- Think Pair Share

Launch

Keep students with the same partners. Give students quiet think time, and then time to share their responses with their partners.

Tell students that, in the last activity, everyone traveled the same distance but in different times. Now they will analyze a situation in which two people travel for the same amount of time but cover different distances.

If students have digital access, they can use an applet to explore the problem and solidify their thinking. This applet is similar to the one used in the "grocery shopping" lessons. To maximize the

effectiveness of the applet, encourage students to have their data from the previous activities organized.

Support for English Language Learners

Writing: MLR5 Co-Craft Questions. Present students with the situation "Lin and Diego both ran for 10 seconds, each at their own constant speed. Lin ran 40 meters and Diego ran 55 meters" without revealing the questions that follow, and ask students to write possible mathematical questions about the situation. Then, invite students to share their questions with a partner before sharing with the whole class. This helps students produce the language of mathematical questions and talk about the relationships between the two speeds in this task. Ask students to use the phrase "at a constant speed" so that they must reason about its mathematical meaning.

Design Principle(s): Maximize meta-awareness

Anticipated Misconceptions

Instead of dividing 40 by 10, some students may instead calculate $10 \div 40$. Ask them to articulate what the resulting number means (0.25 seconds to travel 1 meter) and contrast that meaning with what the problem is asking (how many meters in one second). Another approach would be to encourage them to draw a double number line and think about how they can figure out what value for distance corresponds to 1 second on the line for elapsed time.

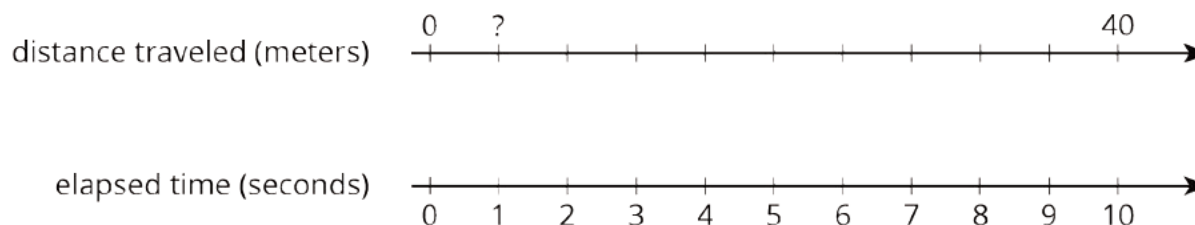

Student Task Statement

Lin and Diego both ran for 10 seconds, each at their own constant speed. Lin ran 40 meters and Diego ran 55 meters.

1. Who was moving faster? Explain your reasoning.
2. How far did each person move in 1 second? If you get stuck, consider drawing double number line diagrams to represent the situations.
3. Use your data from the previous activity to find how far *you* could travel in 10 seconds at your quicker speed.

4. Han ran 100 meters in 20 seconds at a constant speed. Is this speed faster, slower, or the same as Lin's? Diego's? Yours?

Student Response

1. Diego ran faster, covering a greater distance in the same amount of time.
2. Lin ran 4 meters per second, and Diego ran 5.5 meters per second.
3. Answers vary, but 10 times the distance traveled in 1 second.
4. Han ran 5 meters per second, which is faster than Lin's speed, but slower than Diego's.

Are You Ready for More?

Lin and Diego want to run a race in which they will both finish when the timer reads exactly 30 seconds. Who should get a head start, and how long should the head start be?

Student Response

Lin needs a 45-meter head start. Lin will travel 120 meters in 30 seconds, and Diego will travel 165 meters in 30 seconds.

Activity Synthesis

Select students who reasoned differently to share. Some students will know that Diego ran faster, simply because he ran further, but this reasoning is not always correct. Han runs further, but is slower than Diego because he had more time. Be sure to attend to both distance and time when making the comparison. Help students draw connections between the different ways they represented and reasoned about the problem.

During the discussion, keep as much emphasis as possible on the concept of *meters per second*.

Lesson Synthesis

The work in this lesson parallels the work in the previous lesson. Knowing a speed in **meters per second** gives the same kind of information as knowing a unit price in dollars per item.

The overall objective is for students to see consistencies in the underlying mathematical structure of these contexts.

Time permitting, discuss the ways in which this work was similar to the work on unit prices, asking students to state in their own words which actions and methods felt consistent.

9.4 Train Speeds

Cool Down: 5 minutes

Addressing

- 6.RP.A.3.b

Student Task Statement

Two trains are traveling at constant speeds on different tracks.

Train A:

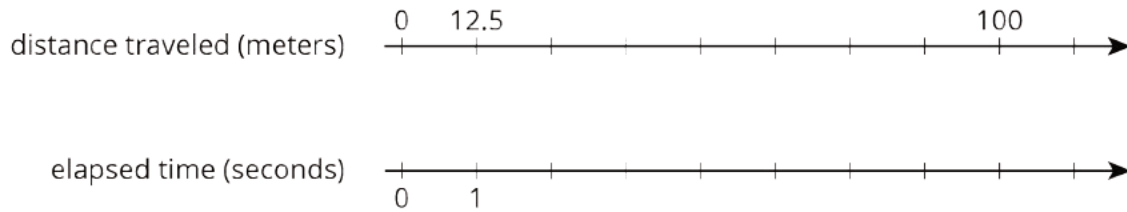

Train B:

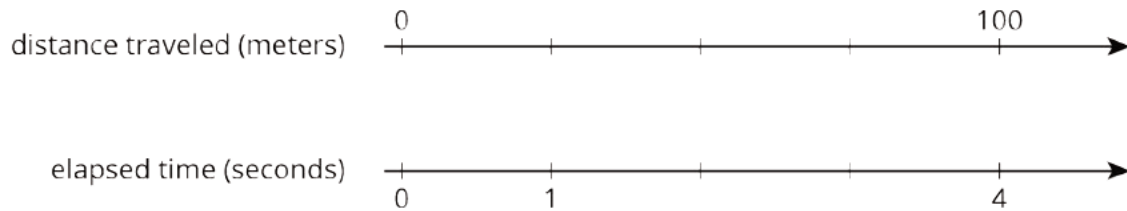

Which train is traveling faster? Explain your reasoning.

Student Response

Train B travels faster because it only took 4 seconds to travel 100 meters, while it took Train A 8 seconds to go the same distance.

Train B travels faster because its speed is 25 meters per second. Train A's speed is 12.5 meters per second.

Student Lesson Summary

Suppose a train traveled 100 meters in 5 seconds at a constant speed. To find its speed in **meters per second**, we can create a double number line:

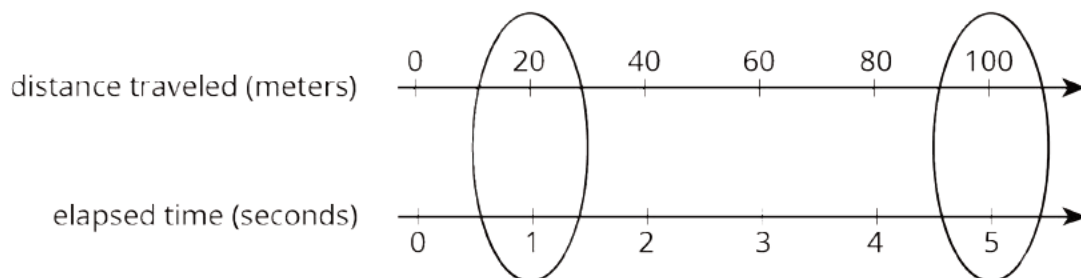

The double number line shows that the train's speed was 20 meters per second. We can also find the speed by dividing: $100 \div 5 = 20$.

Once we know the speed in meters per second, many questions about the situation become simpler to answer because we can multiply the amount of time an object travels by the speed to get the distance. For example, at this rate, how far would the train go in 30 seconds? Since $20 \cdot 30 = 600$, the train would go 600 meters in 30 seconds.

Glossary

- meters per second

Lesson 9 Practice Problems

Problem 1

Statement

Han ran 10 meters in 2.7 seconds. Priya ran 10 meters in 2.4 seconds.

- Who ran faster? Explain how you know.
- At this rate, how long would it take each person to run 50 meters? Explain or show your reasoning.

Solution

- Priya ran faster. Sample explanation: Priya ran the same distance (10 meters) in *less* time than Han. This means she was running faster.
- At this rate, it would take Han 13.5 seconds to run 50 meters. Since 50 meters is 5 times 10 meters, the time it would take is 5 times 2.7 seconds. It would take Priya 12 seconds, which is 5 times 2.4 seconds, to run 50 meters.

Problem 2

Statement

A scooter travels 30 feet in 2 seconds at a constant speed.

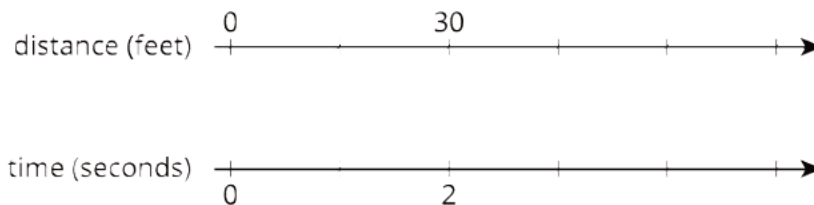

- What is the speed of the scooter in feet per second?
- Complete the double number line to show the distance the scooter travels after 1, 3, 4, and 5 seconds.

- c. A skateboard travels 55 feet in 4 seconds. Is the skateboard going faster, slower, or the same speed as the scooter?

Solution

- a. 15 feet per second
- b. Distance: 0, 15, 30, 45, 60, 75. Time: 0, 1, 2, 3, 4, 5.
- c. Slower. The scooter travels 60 feet in 4 seconds, so it is going faster than the skateboard, which travels 55 feet in 4 seconds.

Problem 3

Statement

A cargo ship traveled 150 nautical miles in 6 hours at a constant speed. How far did the cargo ship travel in one hour?

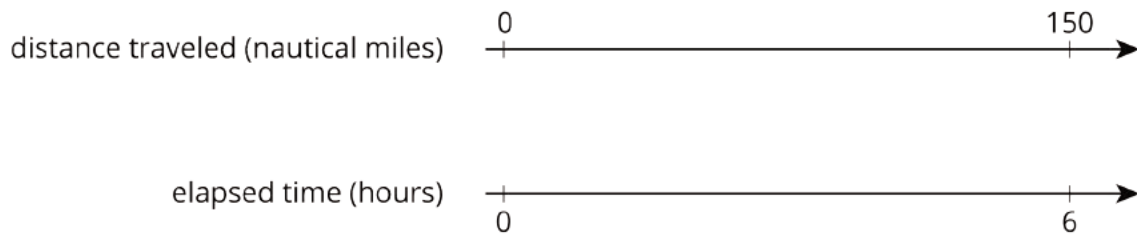

Solution

The ship travels 25 nautical miles in 1 hour. Possible strategy:

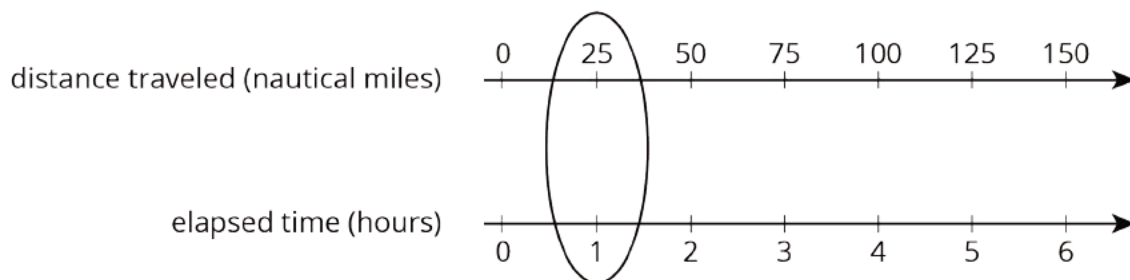

Problem 4

Statement

A recipe for pasta dough says, "Use 150 grams of flour per large egg."

- a. How much flour is needed if 6 large eggs are used?
- b. How many eggs are needed if 450 grams of flour are used?

Solution

- a. 900 grams
- b. 3 eggs

(From Unit 2, Lesson 3.)

Problem 5

Statement

The grocery store is having a sale on frozen vegetables. 4 bags are being sold for \$11.96. At this rate, what is the cost of:

- a. 1 bag
- b. 9 bags

Solution

- a. \$2.99
- b. \$26.91

(From Unit 2, Lesson 8.)

Problem 6

Statement

A pet owner has 5 cats. Each cat has 2 ears and 4 paws.

- a. Complete the double number line to show the numbers of ears and paws for 1, 2, 3, 4, and 5 cats.

number of ears $\begin{array}{c} 0 \\ | \\ \hline \longrightarrow \end{array}$

- b. If there are 3 cats in the room, what is the ratio of ears to paws?

number of paws $\begin{array}{c} | \\ \hline 0 \\ \longrightarrow \end{array}$

- a. If there are 4 cats in the room, what is the ratio of paws to ears?
- b. If all 5 cats are in the room, how many more paws are there than ears?

Solution

- a. Ears: 2, 4, 6, 8, 10; Paws: 4, 8, 12, 16, 20
- b. 6 : 12
- c. 16 : 8
- d. 10

(From Unit 2, Lesson 7.)

Problem 7

Statement

Each of these is a pair of equivalent ratios. For each pair, explain why they are equivalent ratios or draw a representation that shows why they are equivalent ratios.

- a. $5 : 1$ and $15 : 3$
- b. $25 : 5$ and $10 : 2$
- c. $198 : 1,287$ and $2 : 13$

Solution

Answers vary. Sample response:

- a. Multiplying the numbers in the first ratio by 3 gives the numbers in the second ratio.
- b. Multiplying the numbers in the second ratio by 10 gives the numbers in the first ratio.
- c. Multiply 2 by 99 (or $100 - 1$), to get 198 (or $200 - 2$), and multiply 13 by 99, to get 1,287 ($1,300 - 13$).

(From Unit 2, Lesson 5.)

Lesson 10: Comparing Situations by Examining Ratios

Goals

- Choose and create diagrams to help compare two situations and explain whether they happen at the same rate.
- Justify that two situations do not happen at the same rate by finding a ratio to describe each situation where the two ratios share one value but not the other, i.e., $a : b$ and $a : c$, or $x : z$ and $y : z$.
- Recognize that a question asking whether two situations happen “at the same rate” is asking whether the ratios are equivalent.

Learning Targets

- I can decide whether or not two situations are happening at the same rate.
- I can explain what it means when two situations happen at the same rate.
- I know some examples of situations where things can happen at the same rate.

Lesson Narrative

In previous lessons, students learned that if two situations involve equivalent ratios, we can say that the situations are described by the **same rate**. In this lesson, students compare ratios to see if two situations in familiar contexts involve the same rate. The contexts and questions are:

- Two people run different distances in the same amount of time. Do they run at the same speed?
- Two people pay different amounts for different numbers of concert tickets. Do they pay the same cost per ticket?
- Two recipes for a drink are given. Do they taste the same?

In each case, the numbers are purposely chosen so that reasoning directly with equivalent ratios is a more appealing method than calculating how-many-per-one and then scaling. The reason for this is to reinforce the concept that equivalent ratios describe the same rate, before formally introducing the notion of unit rate and methods for calculating it. However, students can use any method. Regardless of their chosen approach, students need to be able to explain their reasoning (MP3) in the context of the problem.

Alignments

Addressing

- 6.RP.A.2: Understand the concept of a unit rate a/b associated with a ratio $a : b$ with $b \neq 0$, and use rate language in the context of a ratio relationship. \$Expectations for unit rates in this grade are limited to non-complex fractions.
- 6.RP.A.3: Use ratio and rate reasoning to solve real-world and mathematical problems, e.g., by reasoning about tables of equivalent ratios, tape diagrams, double number line diagrams, or equations.
- 6.RP.A.3.b: Solve unit rate problems including those involving unit pricing and constant speed. For example, if it took 7 hours to mow 4 lawns, then at that rate, how many lawns could be mowed in 35 hours? At what rate were lawns being mowed?

Instructional Routines

- Anticipate, Monitor, Select, Sequence, Connect
- MLR1: Stronger and Clearer Each Time
- MLR6: Three Reads
- Think Pair Share

Student Learning Goals

Let's use ratios to compare situations.

10.1 Treadmills

Warm Up: 10 minutes

In this activity, students encounter two distance-time ratios in which one quantity (distance) has the same value and the other quantity (time) has different values. Students interpret what the ratios mean in context, i.e., in terms of the speeds of two runners. There are several ways to reason about this with or without double number lines. Students may argue that since both runners ran for the same distance but Mai ran a shorter amount of time, she ran at a greater speed.

Students may also say that if Mai could run 3 miles in 24 minutes, at that speed, she would run more than 3 miles in 30 minutes. Since Jada only ran 3 miles in 30 minutes, Mai ran faster. The double number line that corresponds to these arguments may be as shown below.

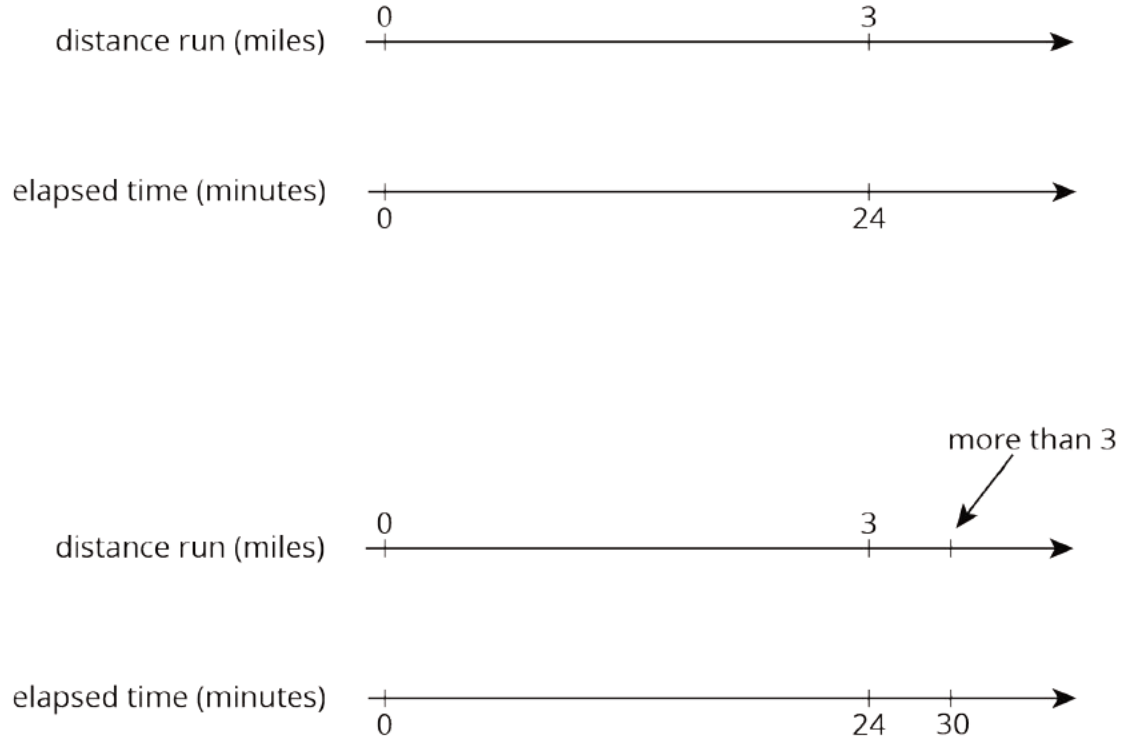

As students work, monitor for the different ways they reason about the situation and identify a few students to share different approaches later.

Addressing

- 6.RP.A.3.b

Instructional Routines

- Anticipate, Monitor, Select, Sequence, Connect
- Think Pair Share

Launch

Explain to students that a treadmill is an exercise machine for walking or running. Explain that while the runner does not actually go anywhere on a treadmill, a computer inside the treadmill keeps track of the distance traveled as if she were running outside.

If desired, this video shows a person starting a treadmill and walking at a constant speed for a few seconds.

Video 'Treadmill' available here: <https://player.vimeo.com/video/304136549>.

Students work on all parts of the activity silently and individually, then share their explanation with a partner.

Anticipated Misconceptions

Because a person running on a treadmill does not actually go anywhere, it may be challenging to think about a distance covered. If this comes up, suggest that students think about running the given distances outside on a straight, flat road at a constant speed.

Student Task Statement

Mai and Jada each ran on a treadmill. The treadmill display shows the distance, in miles, each person ran and the amount of time it took them, in minutes and seconds.

Here is Mai's treadmill display:



Here is Jada's treadmill display:



1. What is the same about their workouts? What is different about their workouts?
2. If each person ran at a constant speed the entire time, who was running faster? Explain your reasoning.

Student Response

1. They both ran the same distance—3 miles. Also, the incline, level, and pulse are the same. The amount of time it took them is different—24 minutes versus 30 minutes. Also, the pace and calories differ.
2. Mai ran faster. She ran 3 miles in less time than it took Jada.

Activity Synthesis

Select a few students to share their reasoning about the speeds of the runners. If no students use a double number line to make an argument, illustrate one of their explanations using a double number line.

Remind students that even though a double number line is not always necessary, it can be a helpful tool to support arguments about ratios in different contexts.

10.2 Concert Tickets

10 minutes (there is a digital version of this activity)

Previously, students worked with ratios in which one quantity (distance run) had the same value and the other (time elapsed) did not. In the context of running, they concluded that the runners did not run at the same rate. Here, students work with two ratios in which neither quantity (number of

tickets bought and money paid) has the same value, and decide if the two people in the situation bought tickets at the same rate. Students may approach the task in several ways. They may use a double number line to generate ratios that are equivalent to $47 : 3$, representing the prices Diego would pay for different number of tickets. Once the price for 9 tickets is determined by scaling up the first ratio, they can compare it to the amount that Andre paid for the same number of tickets.

They may remember, without drawing number lines, that multiplying two values of a ratio by the same number produces a ratio that is equivalent. They may notice that multiplying 3 tickets by 3 results in 9 tickets, making the values for one quantity in the ratios match. They can then compare the two prices for 9 tickets. Alternatively, they may divide Andre's 9 tickets and \$141 payment by 3 to get his price for 3 tickets.

Another approach is to calculate the price of 1 ticket, as students did in a previous lesson. To make this approach less attractive here, the numbers have been deliberately chosen so the price of a single ticket ($\$15\frac{2}{3}$) is not a whole number.

As students work, monitor for those who reason correctly using the three approaches described above.

Addressing

- 6.RP.A.2

Instructional Routines

- Anticipate, Monitor, Select, Sequence, Connect
- MLR6: Three Reads
- Think Pair Share

Launch

Ask students what comes to mind when they hear the term “at the **same rate**”? Ask if they can think of any examples of situations that happen at the same rate. An example is two things traveling at the same speed. Any distance traveled will have the same associated time for things traveling at the same rate. Remind students that when situations happen “at the same rate,” they can be described by ratios that are equivalent.

Give students quiet think time to complete the activity and then time to share their explanation with a partner.

If students have digital access, they can use an applet to explore the problem and justify their reasoning before sharing with a partner. If students have not used the number line applet in previous activities or need a refresher as to how to use it, demonstrate the treadmill problem with the applet.

Support for Students with Disabilities

Representation: Internalize Comprehension. Activate background knowledge about finding ratios that are equivalent. Allow students to use calculators to ensure inclusive participation in the activity.

Supports accessibility for: Memory; Conceptual processing

Support for English Language Learners

Reading: MLR6 Three Reads. This is the first time Math Language Routine 6 is suggested as a support in this course. In this routine, students are supported in reading a mathematical text, situation, or word problem three times, each with a particular focus. During the first read, students focus on comprehending the situation; during the second read, students identify quantities; during the third read, students brainstorm possible strategies to answer the question. The question to be answered does not become a focus until the third read so that students can make sense of the whole context before rushing to a solution. The purpose of this routine is to support students' reading comprehension as they make sense of mathematical situations and information through conversation.

Design Principle(s): Support sense-making

How It Happens:

1. In the first read, students read the problem with the goal of comprehending the situation.

Invite a student to read the problem aloud while everyone else reads with them and then ask, "What is this situation about?"

Allow one minute to discuss with a partner, and then share with the whole class. A clear response would be: "Diego and Andre both bought tickets to a concert."

2. In the second read, students analyze the mathematical structure of the story by naming quantities.

Invite students to read the problem aloud with their partner or select a different student to read to the class and then prompt students by asking, "What can be counted or measured in this situation? For now we don't need to focus on how many or how much of anything, but what can we count in this situation?" Give students one minute of quiet think time followed by another minute to share with their partner. Quantities may include: the number of tickets Diego bought, the number of tickets Andre bought, the amount Diego paid, the amount Andre paid, the rate of dollars per ticket that Diego paid, the rate of dollars per ticket that Andre paid.

Call attention to the fact that whether we are talking about Andre or Diego, the two important quantities in this situation are: number of tickets, and amount paid in dollars.

3. In the third read, students brainstorm possible strategies to answer the question, "Did they pay at the same rate?"

Invite students to read the problem aloud with their partner or select a different student to read to the class. Instruct students to think of ways to approach the question without actually solving the problem.

Consider using these questions to prompt students: “How would you approach this question?,” “What strategy or method would you try first?,” and “Can you think of a different way to solve it?”

Give students one minute of quiet think time followed by another minute to discuss with their partner. Provide these sentence frames as partners discuss: “To compare the rates, I would use a double number line by....”, “One way to approach the question would be to....”

Sample responses include: “I would figure out how much each person paid for one ticket”, “I know that if I multiply 3 tickets by 3, I get 9, so I would see what happens when I multiply \$47 by 3”, “I would draw a diagram to figure out how much 3 groups of three tickets would cost at Diego’s rate”, and “I would use a double number line to scale up the rate for Diego’s tickets (or scale down the rate for Andre’s tickets) to see if they are the same rate.” This will help students concentrate on making sense of the situation before rushing to a solution or method.

4. As partners are discussing their strategies, select 1–2 students to share their ideas with the whole class. As students are presenting ideas to the whole class, create a display that summarizes ideas about the question.

Listen for quantities that were mentioned during the second read, and take note of strategies for relating number of tickets to cost (amount paid).

5. Post the summary where all students can use it as a reference, and suggest that students consider using the Three Reads routine for the next activity as well.

Student Task Statement

Diego paid \$47 for 3 tickets to a concert. Andre paid \$141 for 9 tickets to a concert. Did they pay at the **same rate**? Explain your reasoning.

Student Response

Yes, Andre paid at the same rate. Sample explanation: Since 9 is $3 \cdot 3$, multiply 47 by 3. $47 \cdot 3 = 141$. Diego would have paid \$141 for 9 tickets if he paid at the same rate he did for 3 tickets. Since this is what Andre paid for 9 tickets, they paid at the same rate.

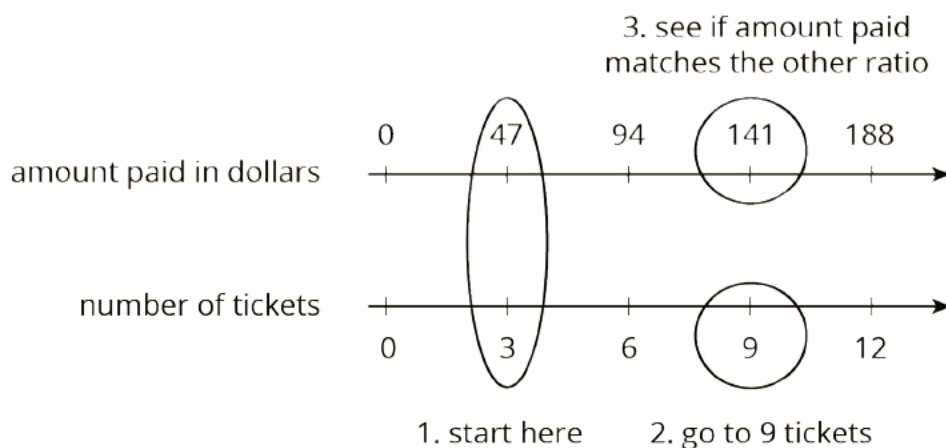

Activity Synthesis

The main strategy to highlight here is one that could tell us what Diego would pay for 9 tickets if he paid at the same rate as he did for 3 tickets. For 9 tickets, he would have paid \$141, which is what Andre paid for 9 tickets and which tells us that they paid at the same rate.

Select 2–3 students to present their work to the class in the order of their methods:

- Correct use of a double number line to show that the given ratios are equivalent.
- Correct use of multiplication (or division) without using a double number line.
- (Optional) Correct use of unit price (i.e., by finding out $141 \div 9$ and $47 \div 3$). Though it's a less efficient approach here, the outcome also shows that the two people paid at the same rate.

Recap that using equivalent ratios to make one of the corresponding quantities the same can help us compare the other quantity and tell whether the situations involve the same rate.

10.3 Sparkling Orange Juice

15 minutes (there is a digital version of this activity)

Here, students compare the tastes of two sparkling orange juice mixtures, which involves reasoning about whether the two situations involve equivalent ratios. The problem is more challenging because no values of the quantities match or are multiples of one another. Instead of finding an equivalent ratio for one recipe so that it matches the other, students need to do so for *both* recipes.

To answer the question, students can either make the values of the soda water match and then compare the orange juice amounts, or make the orange juice amounts match and compare the values for soda water. Again, they may use a double number line, multiplication, and possibly finding how much of one quantity per 1 unit of the other quantity.

Addressing

- 6.RP.A.3

Instructional Routines

- MLR1: Stronger and Clearer Each Time
- Think Pair Share

Launch

Introduce the task by saying that some people make sparkling orange juice by mixing orange juice and soda water. Ask students to predict how the drink would taste if we mixed a *huge* amount of soda water with just a *little bit* of orange juice (it would not have a very orange-y flavor), or the other way around.

Explain that they will now compare the tastes of two sparkling orange juice recipes. Remind them that we previously learned that making larger or smaller batches of the same recipe does not change its taste.

Give students quiet think time to complete the activity and then time to share their explanation with a partner.

If students have digital access, they can use an applet to explore the problem and justify their reasoning before sharing with a partner.

Support for Students with Disabilities

Action and Expression: Internalize Executive Functions. Provide students with printed double number lines to represent Lin's and Noah's recipes.

Supports accessibility for: Language; Organization

Support for English Language Learners

Writing, Conversing: MLR1 Stronger and Clearer Each Time. Use this routine to help students improve their writing, by providing them with multiple opportunities to clarify their explanations through conversation. At the appropriate time, give students time to meet with 2–3 partners, to share their response to the question, “How do the two mixtures compare in taste?” Students should first check to see if they agree with each other about how Lin and Noah’s mixtures compare. Provide listeners with prompts for feedback that will help their partner add detail to strengthen and clarify their ideas. For example, “How did you use double number lines to solve this problem?” or “Can you say more about what each ratio means?” Give students with 3–4 minutes to revise their initial draft based on feedback from their peers. This will help strengthen students’ understanding of how to determine whether two situations involve equivalent ratios.

Design Principle(s): Support sense-making; Optimize output (for explanation)

Anticipated Misconceptions

Some students may say that these two recipes would taste the same because they each use 1 more liter of soda water than orange juice (an additive comparison instead of a multiplicative comparison). Remind them of when we made batches of drink mix, and that mixtures have the same taste when mixed in equivalent ratios.

Student Task Statement

Lin and Noah each have their own recipe for making sparkling orange juice.

- Lin mixes 3 liters of orange juice with 4 liters of soda water.
- Noah mixes 4 liters of orange juice with 5 liters of soda water.

How do the two mixtures compare in taste? Explain your reasoning.

Student Response

Lin’s mixture tastes a little more like soda water and Noah’s mixture tastes a little more like orange juice.

Double number line for Lin’s 3 : 4 recipe:

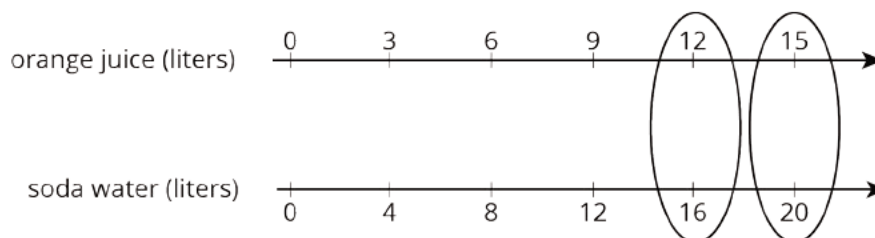

Double number line for Noah’s 4 : 5 recipe:

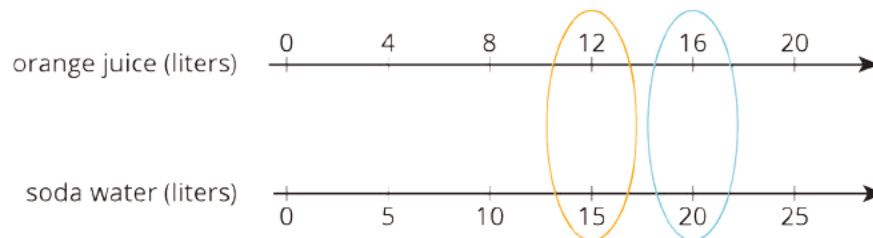

With these double number line diagrams, we can see that the mixtures do not taste the same. For 12 liters of orange juice, the first recipe has 16 liters of soda water and the second recipe has 15 liters of soda water, so Noah's mixture has a stronger orange flavor. We can also see that for 20 liters of soda water, the first recipe has less orange juice than the second recipe, so Lin's mixture has a weaker orange flavor.

Are You Ready for More?

1. How can Lin make her sparkling orange juice taste the same as Noah's just by adding more of one ingredient? How much will she need?
2. How can Noah make his sparkling orange juice taste the same as Lin's just by adding more of one ingredient? How much will he need?

Student Response

1. If Lin adds $\frac{1}{5}$ liter of orange juice, then the ratio of juice to sparkling water will be $3\frac{1}{5} : 4$, which you can see is equivalent to $16 : 20$ if you multiply by 5, which is equivalent to Noah's ratio.
2. If Noah adds $\frac{1}{3}$ liter of sparkling water, then the ratio of juice to sparkling water will be $4 : 5\frac{1}{3}$, which you can see is equivalent to $12 : 16$ if you multiply by 3, which is equivalent to Lin's ratio.

Activity Synthesis

Display two double number line diagrams for all to see: one that represents batches of the $3 : 4$ recipe and another that represents batches of the $4 : 5$ recipe. Scale them up to show enough batches of each recipe to be able to make comparisons.

Ask students to explain how they can tell that the $4 : 5$ recipe tastes more orange-y. Elicit both explanations: comparing the amount of soda water for the same amount of orange juice, and the other way around. Ensure students can articulate *why* each way of comparing means that the second recipe is more orange-y.

If any students calculated a unit rate for each recipe, you might consider inviting them to share, but help them be careful with their choice of words. It is important to say, for example, "In the first recipe, there is $\frac{3}{4}$ or 0.75 cup of orange juice per cup of soda water, but in the second recipe, there is $\frac{4}{5}$ or 0.8 cup of orange juice per cup of soda water." A student with this response would be comparing the number of cups of orange juice for every 1 cup of soda water in each mixture. (Note: if this approach comes up, consider taking this opportunity to discuss fraction comparison methods

that students should know from earlier grades. In particular, $\frac{3}{4} = 1 - \frac{1}{4}$ is less than $\frac{4}{5} = 1 - \frac{1}{5}$ because $\frac{1}{5}$ is smaller than $\frac{1}{4}$.)

Lesson Synthesis

This lesson is all about figuring out whether two situations happen at the **same rate** by comparing one quantity when the other quantity is the same. In order to do that, it's helpful to generate equivalent ratios.

Briefly review the strategies used in the three activities in this lesson.

- How did we know that the people on the treadmill were not going the same speed? (They went different distances in the same amount of time.)
- How did we know the people paid the same rate for the concert tickets? (We figured out how much one person would have paid for 9 tickets at the same rate he paid for 3. We compared that to what the other person paid for 9 tickets.)
- How did we know that the sparkling orange juice recipes did not taste the same? (We made equivalent ratios so we could compare orange juice for the same amount of soda water or compare soda water for the same amount of orange juice.)
- How were all these problems alike? (We used equivalent ratios to make one part of the ratio the same and compared the other part.)

10.4 Comparing Runs

Cool Down: 5 minutes

Addressing

- 6.RP.A.3.b

Student Task Statement

Andre ran 2 kilometers in 15 minutes, and Jada ran 3 kilometers in 20 minutes. Both ran at a constant speed.

Did they run at the *same* speed? Explain your reasoning.

Student Response

They did not run at the same speed. There are many ways to justify this response. Here are some examples:

Andre would have run 6 kilometers in 45 minutes, and Jada would have run 6 kilometers in 40 minutes. Jada completes the 6 kilometers in less time, so she runs at a faster speed than Andre.

Andre would have run 8 kilometers in 60 minutes, and Jada would have run 9 kilometers in 60 minutes. Jada travels further in the same amount of time, so she runs at a faster speed than Andre.

These examples, while they also explain why Jada runs faster, also explain why the two runners did not run at the *same* speed.

Student Lesson Summary

Sometimes we want to know whether two situations are described by the **same rate**. To do that, we can write an equivalent ratio for one or both situations so that one part of their ratios has the same value. Then we can compare the other part of the ratios.

For example, do these two paint mixtures make the same shade of orange?

- Kiran mixes 9 teaspoons of red paint with 15 teaspoons of yellow paint.
- Tyler mixes 7 teaspoons of red paint with 10 teaspoons of yellow paint.

Here is a double number line that represents Kiran's paint mixture. The ratio $9 : 15$ is equivalent to the ratios $3 : 5$ and $6 : 10$.

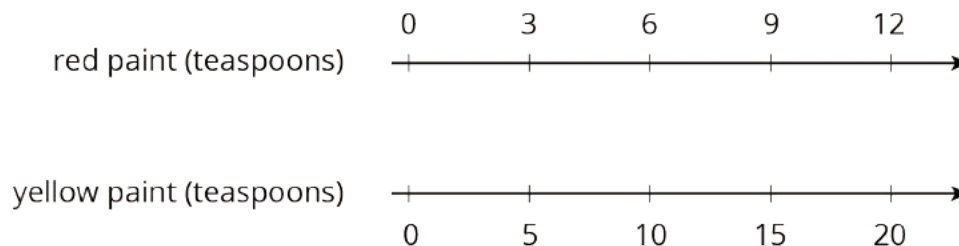

For 10 teaspoons of yellow paint, Kiran would mix in 6 teaspoons of red paint. This is less red paint than Tyler mixes with 10 teaspoons of yellow paint. The ratios $6 : 10$ and $7 : 10$ are not equivalent, so these two paint mixtures would not be the same shade of orange.

When we talk about two things happening at the same rate, we mean that the ratios of the quantities in the two situations are equivalent. There is also something specific about the situation that is the same.

- If two ladybugs are moving at the same rate, then they are traveling at the *same constant speed*.
- If two bags of apples are selling for the same rate, then they have the *same unit price*.
- If we mix two kinds of juice at the same rate, then the mixtures have the *same taste*.
- If we mix two colors of paint at the same rate, then the mixtures have the *same shade*.

Glossary

- same rate

Lesson 10 Practice Problems

Problem 1

Statement

A slug travels 3 centimeters in 3 seconds. A snail travels 6 centimeters in 6 seconds. Both travel at constant speeds. Mai says, "The snail was traveling faster because it went a greater distance." Do you agree with Mai? Explain or show your reasoning.

Solution

Answers vary. Sample responses:

- I disagree. The slug and the snail are both traveling 1 centimeter per second. They are traveling at the same speed.
- I disagree. The double number line for the slug shows that in 6 seconds it also travels 6 centimeters.

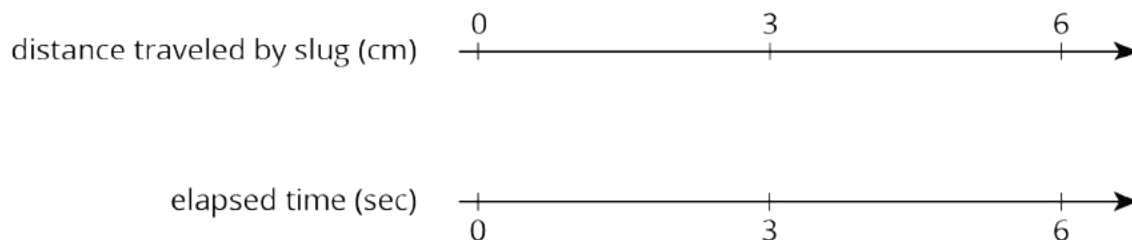

Problem 2

Statement

If you blend 2 scoops of chocolate ice cream with 1 cup of milk, you get a milkshake with a stronger chocolate flavor than if you blended 3 scoops of chocolate ice cream with 2 cups of milk. Explain or show why.

Solution

Answers vary. Sample responses:

- 3 scoops of chocolate ice cream with 2 cups of milk is 1.5 scoops of chocolate ice cream per cup of milk. This is less chocolate ice cream per cup of milk than in the first mixture (2 scoops of chocolate ice cream per cup of milk), so the first mixture has stronger chocolate flavor.
- 2 scoops of chocolate ice cream with 1 cup of milk will taste the same as 4 scoops of chocolate ice cream with 2 cups of milk. This mixture has an extra scoop of chocolate ice cream so will taste more chocolatey than 3 scoops of chocolate ice cream and 2 cups of milk.

Problem 3

Statement

There are 2 mixtures of light purple paint.

- Mixture A is made with 5 cups of purple paint and 2 cups of white paint.
- Mixture B is made with 15 cups of purple paint and 8 cups of white paint.

Which mixture is a lighter shade of purple? Explain your reasoning.

Solution

Mixture B is lighter. Explanations vary. Sample responses:

- Mixture A contains 2.5 cups of purple paint per cup of white paint. Mixture B contains only 1.875 cups of purple paint per cup of white paint. Less purple paint for the same amount of white paint will result in a lighter shade of purple.
- The ratio of purple paint to white paint in Mixture A is $5 : 2$. The ratio of purple paint to white paint in Mixture B is $15 : 8$. The amount of purple paint in Mixture B is 3 times the amount of Mixture A, but the amount of white paint in B is 4 times the amount of A.

Problem 4

Statement

Tulip bulbs are on sale at store A, at 5 for \$11.00, and the regular price at store B is 6 for \$13. Is each store pricing tulip bulbs at the same rate? Explain how you know.

Solution

No. Explanations vary. Sample response: At store A, 30 bulbs would cost \$66, but at store B, 30 bulbs would cost \$65.

Problem 5

Statement

A plane travels at a constant speed. It takes 6 hours to travel 3,360 miles.

- What is the plane's speed in miles per hour?
- At this rate, how many miles can it travel in 10 hours?

Solution

- 560 because $3,360 \div 6 = 560$.
- In 10 hours, it can travel 5,600 miles because $10 \cdot 560 = 5,600$.

(From Unit 2, Lesson 9.)

Problem 6

Statement

A pound of ground beef costs \$5. At this rate, what is the cost of:

- a. 3 pounds?
- b. $\frac{1}{2}$ pound?
- c. $\frac{1}{4}$ pound?
- d. $\frac{3}{4}$ pound?
- e. $3\frac{3}{4}$ pounds?

Solution

- a. \$15 (because $5 \cdot 3 = 15$)
- b. \$2.50 (because $\frac{1}{2} \cdot 5 = 2\frac{1}{2}$)
- c. \$1.25 (because $\frac{1}{4} \cdot 5 = 1\frac{1}{4}$)
- d. \$3.75 (three times the cost of $\frac{1}{4}$ pound)
- e. \$18.75 (the total cost of 3 pounds and $\frac{3}{4}$ pound)

(From Unit 2, Lesson 8.)

Problem 7

Statement

In a triple batch of a spice mix, there are 6 teaspoons of garlic powder and 15 teaspoons of salt. Answer the following questions about the mix. If you get stuck, create a double number line.

- a. How much garlic powder is used with 5 teaspoons of salt?
- b. How much salt is used with 8 teaspoons of garlic powder?
- c. If there are 14 teaspoons of spice mix, how much salt is in it?
- d. How much more salt is there than garlic powder if 6 teaspoons of garlic powder are used?

Solution

- a. 2 teaspoons
- b. 20 teaspoons
- c. 10 teaspoons
- d. 9 teaspoons

(From Unit 2, Lesson 7.)

Section: Solving Ratio and Rate Problems

Lesson 11: Representing Ratios with Tables

Goals

- Comprehend the words “row” and “column” (in written and spoken language) as they are used to describe a table of equivalent ratios.
- Explain (orally and in writing) how to find a missing value in a table of equivalent ratios.
- Interpret a table of equivalent ratios that represents different sized batches of a recipe.

Learning Targets

- If I am looking at a table of values, I know where the rows are and where the columns are.
- When I see a table representing a set of equivalent ratios, I can come up with numbers to make a new row.
- When I see a table representing a set of equivalent ratios, I can explain what the numbers mean.

Lesson Narrative

Over the course of this unit, students learn to work with ratios using different representations. They began by using discrete diagrams to represent ratios and to identify equivalent ratios. Later, they reasoned more efficiently about ratios using double number lines. Here, they encounter situations in which using a double number line poses challenges and for which a different representation would be helpful. Students learn to organize a set of equivalent ratios in a **table**, which is a more abstract but also a more flexible tool for solving problems.

Although different representations are encouraged at different points in the unit, allowing students to use any representation that accurately represents a situation and encouraging them to compare the efficiency of different methods will develop their ability to make strategic choices about representations (MP5). Whatever choices they make, they should be encouraged to explain how their method works in solving a problem.

Alignments

Building On

- 5.OA.B.3: Generate two numerical patterns using two given rules. Identify apparent relationships between corresponding terms. Form ordered pairs consisting of corresponding terms from the two patterns, and graph the ordered pairs on a coordinate plane. For example, given the rule “Add 3” and the starting number 0, and given the rule “Add 6” and the starting number 0, generate terms in the resulting sequences, and observe that the terms in one sequence are twice the corresponding terms in the other sequence. Explain informally why this is so.

Addressing

- 6.RP.A.3.a: Make tables of equivalent ratios relating quantities with whole-number measurements, find missing values in the tables, and plot the pairs of values on the coordinate plane. Use tables to compare ratios.

Instructional Routines

- Anticipate, Monitor, Select, Sequence, Connect
- MLR7: Compare and Connect
- Think Pair Share

Student Learning Goals

Let's use tables to represent equivalent ratios.

11.1 How Is It Growing?

Warm Up: 10 minutes

This warm-up encourages students to look for regularity in how the tiles in the image are growing. Students may use each color to reason about the total, while others may reason about the way the total tiles increase each time. Emphasize both insights as students share their strategies.

Building On

- 5.OA.B.3

Instructional Routines

- Think Pair Share

Launch

Arrange students in groups of 2. Display the image for all to see and tell students that the collection of images of green and blue tiles is growing. Ask how many total tiles will be in the 4th, 5th and 10th image if it keeps growing in the same way. Tell students to give a signal when they have an answer and strategy. Give students 3 minutes of quiet think time, and then time to discuss their responses and reasoning with their partner.

Student Task Statement

Look for a pattern in the figures.

1. How many total tiles will be in:

a. the 4th figure?

b. the 5th figure?

c. the 10th figure?

2. How do you see it growing?

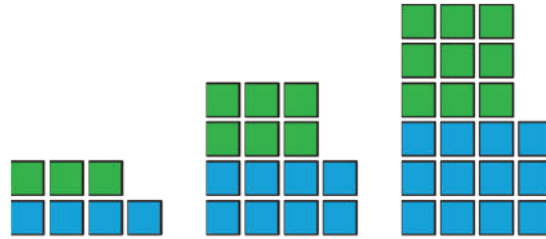

Student Response

1. Answers vary. Sample response: 4th image: 28 tiles, 5th image: 35 tiles, 10th image: 70 tiles

2. Answers vary. Sample response: I see green increasing by 3 each time and blue increasing by 4.

Activity Synthesis

Invite students to share their responses and reasoning. Record and display the different ways of thinking for all to see. If possible, record the relevant reasoning on or near the images themselves. After each explanation, ask the class if they agree or disagree and to explain alternative ways of thinking, referring back to what is happening in the images each time.

11.2 A Huge Amount of Sparkling Orange Juice

15 minutes (there is a digital version of this activity)

Here, students are asked to find missing values for significantly scaled-up ratios. The activity serves several purposes:

- To uncover a limitation of a double number line (i.e., that it is not always practical to extend it to find significantly scaled-up equivalent ratios),
- To reinforce the multiplicative reasoning needed to find equivalent ratios (especially in cases when drawing diagrams or skip counting is inefficient), and
- To introduce a table as a way to represent equivalent ratios.

To find equivalent ratios involving large values, some students may simply try to squeeze numbers on the extreme right side of the paper, ignoring the previously equal intervals. Others may use multiplication (or division) and write expressions or equations to capture the given scenarios. Notice students' reasoning processes, especially any struggles with the double number line (e.g., the lines not being long enough, requiring much marking and writing, the numbers being too large, etc.), as these can motivate a need for a more efficient strategy.

Addressing

- 6.RP.A.3.a

Instructional Routines

- Anticipate, Monitor, Select, Sequence, Connect
- MLR7: Compare and Connect

Launch

Give students 2–3 minutes to work on the first two questions and then ask them to pause. As a class, discuss the two approaches students are likely to take: counting multiples of 4 and 5 up to 36 and 45; and multiplicative reasoning (asking “What number times 4 equals 36?”). Also discuss how a double number line like the one below might be used to support reasoning.

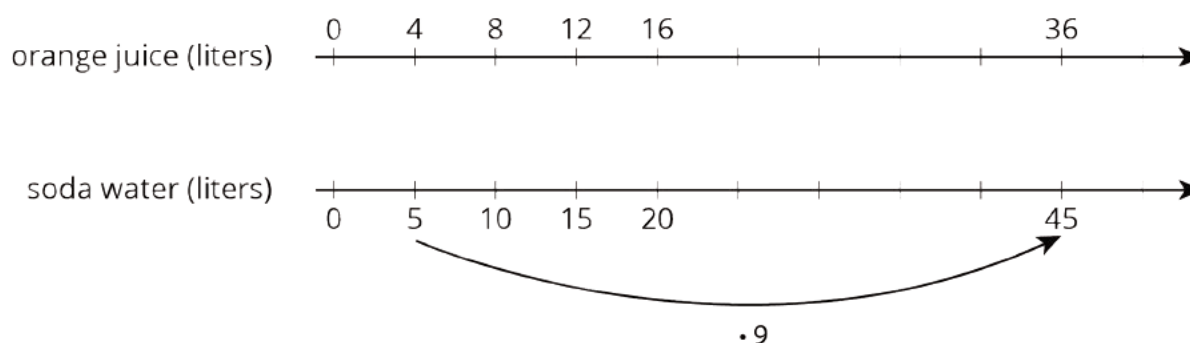

Reiterate the multiplicative relationship between equivalent ratios before students move on.

Support for Students with Disabilities

Representation: Internalize Comprehension. Activate or supply background knowledge about equivalent ratios describing situations that happen at the same rate. Allow students to use calculators to ensure inclusive participation in the activity.

Supports accessibility for: Memory; Conceptual processing

Anticipated Misconceptions

Students may become frustrated when they “run out of number line,” but remind them of what they know about how to find ratios equivalent to $4 : 5$ (they need to multiply both 4 and 5 by the same number). Consider directing their attention to a definition of equivalent ratios displayed in your room or in a previous lesson, or suggesting they reexamine some of the simpler cases (e.g., the relationship between $4 : 5$ and $36 : 45$). Be on the lookout for students trying to tape on more paper to extend their number lines.

Student Task Statement

Noah's recipe for one batch of sparkling orange juice uses 4 liters of orange juice and 5 liters of soda water.

1. Use the double number line to show how many liters of each ingredient to use for different-sized batches of sparkling orange juice.



2. If someone mixes 36 liters of orange juice and 45 liters of soda water, how many batches would they make?
3. If someone uses 400 liters of orange juice, how much soda water would they need?
4. If someone uses 455 liters of soda water, how much orange juice would they need?
5. Explain the trouble with using a double number line diagram to answer the last two questions.

Student Response

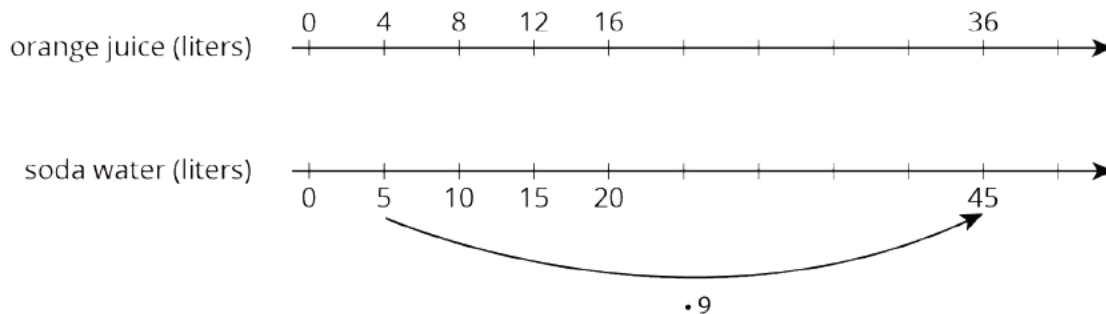

1. Amounts for the first four batch sizes are shown.
2. 9 batches. $4 \cdot 9 = 36$ and $5 \cdot 9 = 45$.
3. 500 liters of soda water. $4 \cdot 100 = 400$ and $5 \cdot 100 = 500$.
4. 364 liters of orange juice. $455 = 5 \cdot 91$ and $4 \cdot 91 = 364$.
5. The numbers I needed to find were too big to fit on the number lines.

Activity Synthesis

After students have a chance to share with a partner, select a few to share their reasoning with the class for the last few questions. Start with students who tried to extend the double number line (if

anyone did so). Discuss any challenges of using the double number line and merits of alternative methods students might have come up with.

Explain that there is a more appropriate tool—a **table**—that can be used to represent equivalent ratios. Display for all to see the double number line from the activity above and a table of equivalent ratios. Explain that even though the table is oriented vertically and the double number line is oriented horizontally, the two representations represent the same ratios. Explain what we mean by **row** and **column** and demonstrate the use of these words. Fill in the table using the values from the orange-soda ratios and, along the way, compare and contrast how the two representations work. A few other key insights to convey:

- Just as it was important to label the double number line, it is important to label the columns of the table to indicate what the values represent (MP6).
- Each row of a table shows a pair of values from a collection of equivalent ratios. Unlike a number line, distances between values do not matter.
- On each line of a double number line, numbers are shown in order. In each column of a table, order is not important, i.e., pairs of values can be placed in any order that is convenient. When complete, the display should look something like this:

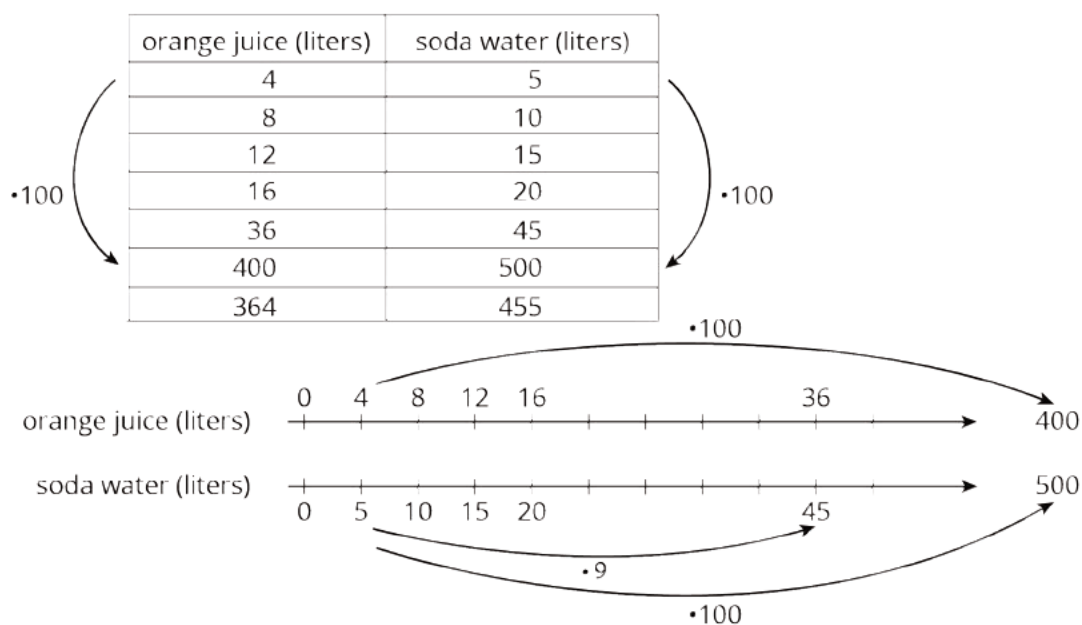

Support for English Language Learners

Representing: MLR7 Compare and Connect. Use this routine to help students make connections between specific features of tables and double number lines. Ask students to describe to a partner how multiplication appears in each representation, and then invite listeners to restate or revoice what they heard, back to their partner, using mathematical language (e.g., product, row, column, table, equivalent ratio, etc.). After students have a chance to share with a partner, select a few to share their reasoning with the class.

Design Principle(s): Maximize meta-awareness

11.3 Batches of Trail Mix

10 minutes

This task gets students to interact with a table in a way that discourages skip counting. Numbers within each column are deliberately out of order. This is intended to encourage students to multiply the pairs of values from a given ratio by the same number and to emphasize that the order in which pairs of values appear is not a necessary part of the structure of a table. (Order within rows, however, is necessary.) The last question reinforces the definition of equivalent ratios.

Students may use the given values (7 and 5) as the basis for every calculation (e.g., for every row, they think “7 times what . . .” or “5 times what . . .”). They may also reason with values from another row (e.g., they may see 250 as $10 \cdot 25$ rather than as $5 \cdot 50$). As students work, notice different approaches.

Addressing

- 6.RP.A.3.a

Launch

Explain that a **table** is just a list of equivalent ratios. In this case, one **column** contains amounts of almonds, and the other column contains corresponding amounts of raisins. Each **row** shows the amount of each ingredients in a particular batch.

Reiterate that multiplying both parts of a ratio by the same non-zero number always creates a ratio that is equivalent to the original ratio.

Anticipated Misconceptions

Students may make patterns that do not yield equivalent ratios. For example, they may think “7 minus 2 is 5, so for the next row, 28 minus 2 is 26.” Or they may think “7 plus 21 is 28, so then 5 plus 21 is 26.” If so, consider:

- Appealing to what students know about batches of recipes. “The second row represents how many batches of trail mix?” (4, because 28 is $7 \cdot 4$.) “Okay, so to make 4 batches of trail mix, how will we figure out how many raisins?” (Also multiply the 5 by 4.)
- Refreshing what students learned about equivalent ratios. “We need a ratio that is equivalent to the ratio represented in row 1. So what do we need to do to the 7 and the 5?” (Multiply them by the same number.)

Students may be unsure about how to find the missing value in the row with 3.5. Encourage them to reason about it the same way they reasoned about the other rows. “We need a ratio that is equivalent to the ratio represented in row 1. So what do we need to do to the 7 and the 5?” They may have to get there by way of division. 7 divided by 2 is 3.5, so 7 times $\frac{1}{2}$ is 3.5; this means multiplying 5 by $\frac{1}{2}$ as well.

Student Task Statement

A recipe for trail mix says: “Mix 7 ounces of almonds with 5 ounces of raisins.” Here is a **table** that has been started to show how many ounces of almonds and raisins would be in different-sized batches of this trail mix.

almonds (oz)	raisins (oz)
7	5
28	
	10
3.5	
	250
56	

1. Complete the table so that ratios represented by each row are equivalent.
2. What methods did you use to fill in the table?
3. How do you know that each row shows a ratio that is equivalent to 7 : 5? Explain your reasoning.

Student Response

1. Here is the table:

almonds (oz)	raisins (oz)
7	5
28	20
14	10
3.5	2.5
350	250
56	40

2. Answers vary.

3. To find each row, multiply 7 and 5 by the same thing. This means that each row has values of a ratio equivalent to 7 : 5.

Are You Ready for More?

You have created a best-selling recipe for chocolate chip cookies. The ratio of sugar to flour is 2 : 5.

Create a table in which each entry represents amounts of sugar and flour that might be used at the same time in your recipe.

- One entry should have amounts where you have fewer than 25 cups of flour.
- One entry should have amounts where you have between 20–30 cups of sugar.
- One entry can have any amounts using more than 500 units of flour.

Student Response

Answers vary. Sample response:

sugar	flour
2	5
8	20
26	65
240	600

Activity Synthesis

Invite one or more students who used multiplicative approaches to share their reasoning with the class. Consider displaying the table and using it to facilitate gesturing and arrow-drawing while students explain. Highlight the strategy of multiplying the 7 and 5 values by the same number.

Lesson Synthesis

Sometimes it is easier to use a **table** rather than a double number line to represent equivalent ratios. Each **row** contains a ratio that is equivalent to all the other ratios, so if we know one row, we can multiply both of its values by the same number to find another row's values.

11.4 Batches of Cookies in a Table

Cool Down: 5 minutes

Addressing

- 6.RP.A.3.a

Student Task Statement

In previous lessons, we worked with a diagram and a double number line that represent this cookie recipe. Here is a table that represents the same situation.

flour (cups)	vanilla (teaspoons)
5	2
15	6
$2\frac{1}{2}$	1

1. Write a sentence that describes a ratio shown in the table.
2. What does the second row of numbers represent?
3. Complete the last row for a different batch size that hasn't been used so far in the table. Explain or show your reasoning.

Student Response

1. Answers vary. Sample responses:
 - The ratio of cups of flour to teaspoons of vanilla is 5 : 2.
 - This recipe uses 5 cups of flour for every 2 teaspoons of vanilla.
 - This recipe uses $2\frac{1}{2}$ cups of flour per teaspoon of vanilla.

- For 15 cups of flour, you need 6 teaspoons of vanilla.
- Answers vary. Sample response: 10 cups of flour and 4 teaspoons of vanilla.

Student Lesson Summary

A **table** is a way to organize information. Each horizontal set of entries is called a *row*, and each vertical set of entries is called a *column*. (The table shown has 2 columns and 5 rows.) A table can be used to represent a collection of equivalent ratios.

Here is a double number line diagram and a table that both represent the situation: "The price is \$2 for every 3 mangos."

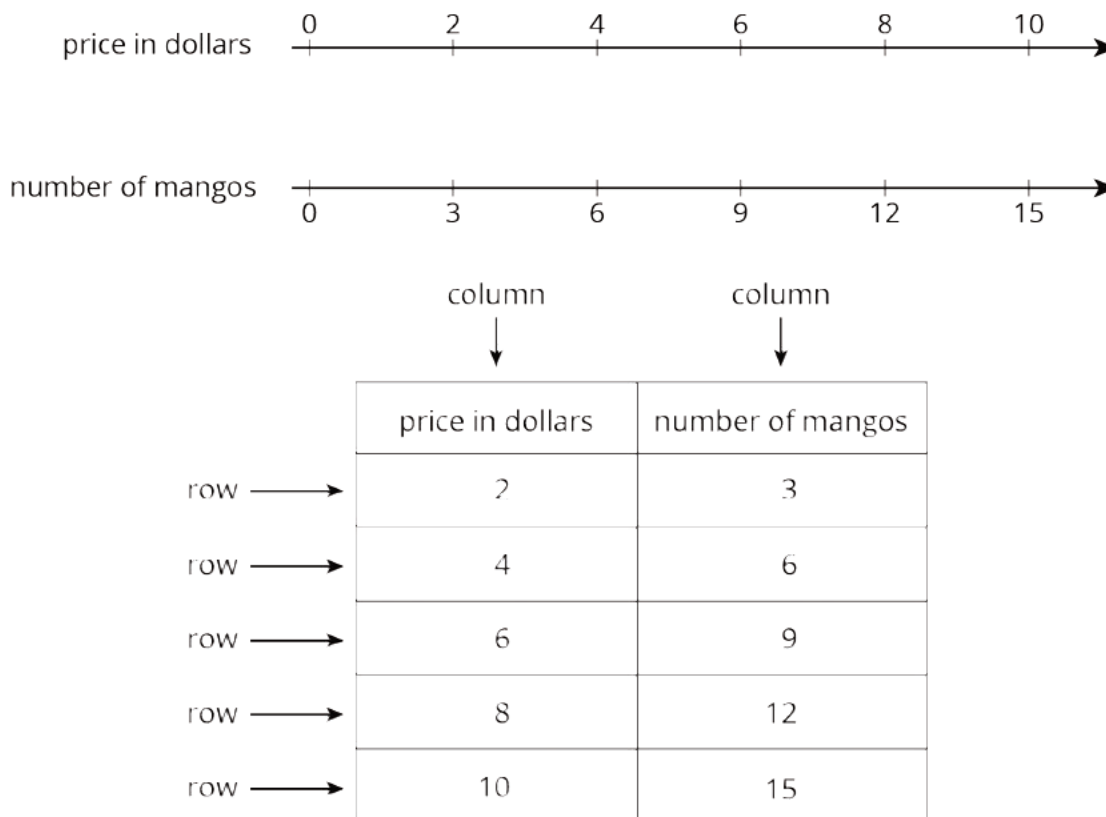

Glossary

- table

Lesson 11 Practice Problems

Problem 1

Statement

Complete the table to show the amounts of yellow and red paint needed for different-sized batches of the same shade of orange paint.

yellow paint (quarts)	red paint (quarts)
5	6

Explain how you know that these amounts of yellow paint and red paint will make the same shade of orange as the mixture in the first row of the table.

Solution

Answers vary. Sample response:

yellow paint (quarts)	red paint (quarts)
5	6
$\frac{5}{4}$	$\frac{3}{2}$ or equivalent
$\frac{5}{2}$	3 or equivalent
$\frac{15}{4}$	$\frac{9}{2}$ or equivalent

Each row is a multiple of the first row.

Problem 2

Statement

A car travels at a constant speed, as shown on the double number line.

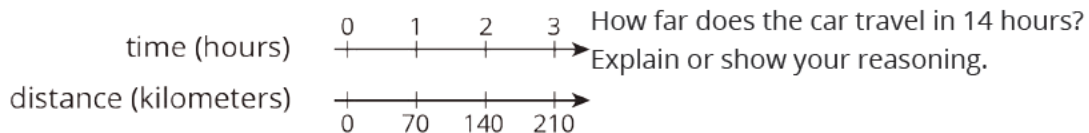

Solution

980 kilometers. Possible strategy: Make a table because there isn't enough room to continue the double number line that far.

time (hours)	distance (kilometers)
1	70
2	140
3	210
14	980

Problem 3

Statement

The olive trees in an orchard produce 3,000 pounds of olives a year. It takes 20 pounds of olives to make 3 liters of olive oil. How many liters of olive oil can this orchard produce in a year? If you get stuck, consider using the table.

olives (pounds)	olive oil (liters)
20	3
100	
3,000	

Solution

The orchard produces 450 liters of olive oil per year. Possible strategy:

olives (pounds)	olive oil (liters)
20	3
100	15
3,000	450

Problem 4

Statement

At a school recess, there needs to be a ratio of 2 adults for every 24 children on the playground. The double number line represents the number of adults and children on the playground at recess.

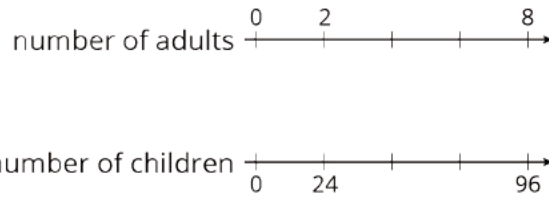

- Label each remaining tick mark with its value.
- How many adults are needed if there are 72 children? Circle your answer on the double number line.

Solution

- Adults: 0, 2, 4, 6, 8. Children: 0, 24, 48, 72, 96.
- 6 adults. The portion of the double number line at 6 adults and 72 children is circled.

(From Unit 2, Lesson 6.)

Problem 5

Statement

While playing basketball, Jada's heart rate goes up to 160 beats per minute. While jogging, her heart beats 25 times in 10 seconds. Assuming her heart beats at a constant rate while jogging, which of these activities resulted in a higher heart rate? Explain your reasoning.

Solution

Playing basketball. Sample explanation: 25 times in 10 seconds means 150 heartbeats per minute ($25 \cdot 6 = 150$). 150 beats per minute is lower than 160 beats per minute, so Jada's heart rate is lower when she goes jogging than when she plays basketball.

(From Unit 2, Lesson 10.)

Problem 6

Statement

A shopper bought the following items at the farmer's market:

- 6 ears of corn for \$1.80. What was the cost per ear?
- 12 apples for \$2.88. What was the cost per apple?
- 5 tomatoes for \$3.10. What was the cost per tomato?

Solution

- \$0.30
- \$0.24
- \$0.62

(From Unit 2, Lesson 8.)

Lesson 12: Navigating a Table of Equivalent Ratios

Goals

- Choose multipliers strategically while solving multi-step problems involving equivalent ratios.
- Describe (orally and in writing) how a table of equivalent ratios was used to solve a problem about prices and quantities.
- Remember that dividing by a whole number is the same as multiplying by an associated unit fraction.

Learning Targets

- I can solve problems about situations happening at the same rate by using a table and finding a “1” row.
- I can use a table of equivalent ratios to solve problems about unit price.

Lesson Narrative

The purpose of this lesson is to develop students’ ability to work with a table of equivalent ratios. It also provides opportunities to compare and contrast different ways of solving equivalent ratio problems.

Students see that a table accommodates different ways of reasoning about equivalent ratios, with some being more direct than others. They notice (MP8) that to find an unknown quantity, they can:

- Find the multiplier that relates two corresponding values in different rows (e.g., “What times 5 equals 8?”) and use that multiplier to find unknown values. (This follows the multiplicative thinking developed in previous lessons.)
- Find an equivalent ratio with one quantity having a value of 1 and use that ratio to find missing values.

	amount earned (\$)	time worked (hours)
$\cdot \frac{1}{5}$	90	5
	18	1
$\cdot 8$	144	8

All tasks in the lesson aim to strengthen students’ understanding of the multiplicative relationships between equivalent ratios—that given a ratio $a : b$, an equivalent ratio may be found by multiplying both a and b by the same factor. They also aim to build students’ awareness of how a table can facilitate this reasoning to varying degrees of efficiency, depending on one’s approach.

Ultimately, the goal of this unit is to prepare students to make sense of situations involving equivalent ratios and solve problems flexibly and strategically, rather than to rely on a procedure (such as “set up a proportion and cross multiply”) without an understanding of the underlying mathematics.

To reason using ratios in which one of the quantities is 1, students are likely to use division. In the example above, they are likely to divide the 90 by 5 to obtain the amount earned per hour. Remind students that dividing by a whole number is the same as multiplying by its reciprocal (a unit fraction) and encourage the use of multiplication (as shown in the activity about hourly wages) whenever possible. Doing so will better prepare students to: 1) scale down, i.e., to find equivalent ratios involving values that are smaller than the given ones, 2) relate fractions to percentages later in the course, and 3) understand division of fractions (including the “invert and multiply” rule) in a later unit.

Alignments

Building On

- 5.NF: Grade 5 - Number and Operations---Fractions

Addressing

- 6.RP.A.3: Use ratio and rate reasoning to solve real-world and mathematical problems, e.g., by reasoning about tables of equivalent ratios, tape diagrams, double number line diagrams, or equations.
- 6.RP.A.3.a: Make tables of equivalent ratios relating quantities with whole-number measurements, find missing values in the tables, and plot the pairs of values on the coordinate plane. Use tables to compare ratios.

Instructional Routines

- MLR5: Co-Craft Questions
- MLR8: Discussion Supports
- Number Talk
- Think Pair Share

Student Learning Goals

Let’s use a table of equivalent ratios like a pro.

12.1 Number Talk: Multiplying by a Unit Fraction

Warm Up: 10 minutes

The purpose of this number talk is to encourage students to use the meaning of fractions and the properties of operations to find the product of fractions and decimals.

In grade 4, students multiplied a fraction by a whole number, reasoning about these problems based on their understandings of multiplication as groups of a number. In grade 5, students multiply fractions by whole numbers, reasoning in terms of taking a part of a part, whether that be by using division or partitioning a whole. In both grade levels, the context of the problem played a significant role in how students reasoned and notated the problem and solution. Based on these understandings, two ideas will be relevant to future work in the unit and are important to emphasize during discussions:

- Dividing by a number is the same as multiplying by its reciprocal.
- The commutative property of multiplication can help us solve a problem regardless of the context.

Building On

- 5.NF

Instructional Routines

- MLR8: Discussion Supports
- Number Talk

Launch

Display one problem at a time. Tell students to give a signal when they have an answer and a strategy. After each problem, give students 1 minute of quiet think time and follow with a whole-class discussion.

Support for Students with Disabilities

Representation: Internalize Comprehension. To support working memory, provide students with sticky notes or mini whiteboards.

Supports accessibility for: Memory; Organization

Student Task Statement

Find the product mentally.

$$\frac{1}{3} \cdot 21$$

$$\frac{1}{6} \cdot 21$$

$$(5.6) \cdot \frac{1}{8}$$

$$\frac{1}{4} \cdot (5.6)$$

Student Response

- $\frac{1}{3} \cdot 21 = 7$. Possible strategies: $21 \div 3$ or $3 \cdot 7$.
- $\frac{1}{6} \cdot 21 = 3.5$. Possible strategies: $21 \div 6$, or divide the product from the first question by 2 because $\frac{1}{6}$ is half of $\frac{1}{3}$.
- $(5.6) \cdot \frac{1}{8} = 0.7$. Possible strategies: $5.6 \div 8$ or $8 \cdot (0.7)$.
- $\frac{1}{4} \cdot (5.6) = 1.4$. Possible strategies: $5.6 \div 4$, or multiply the product from the third question by 2 because $\frac{1}{4}$ is twice as much as $\frac{1}{8}$.

Activity Synthesis

Ask students to share their strategies for each problem. Record and display their explanations for all to see. Ask students if or how the factors in the problem impacted their strategy choice. To involve more students in the conversation, consider asking:

- "Who can restate ___'s reasoning in a different way?"
- "Did anyone solve the problem the same way but would explain it differently?"
- "Did anyone solve the problem in a different way?"
- "Does anyone want to add on to ___'s strategy?"
- "Do you agree or disagree? Why?"

Support for English Language Learners

Speaking: MLR8 Discussion Supports: Display sentence frames to support students when they explain their strategy. For example, "First, I ___ because . . ." or "I noticed ___ so I . . ." Some students may benefit from the opportunity to rehearse what they will say with a partner before they share with the whole class.

Design Principle(s): Optimize output (for explanation)

12.2 Comparing Taco Prices

10 minutes

The purpose of this activity is to encourage students to use a table to find the price for one taco for two different situations. Students are likely to divide the cost of the tacos by the number of tacos to find the cost for one taco, which is appropriate. Use the opportunity to remind students that dividing by a whole number is the same as multiplying by its reciprocal (a unit fraction). This insight will come in handy in future activities and lessons.

Addressing

- 6.RP.A.3.a

Instructional Routines

- MLR5: Co-Craft Questions

Launch

Tell students that we usually use tables to show equivalent ratios, but since we do not know in advance whether the ratios of number of tacos to price will be the same, we might want to keep track of them in separate tables.

Arrange students in groups of 2. Give students 3 minutes of quiet think time, and then time to discuss their responses and reasoning with their partner.

Support for English Language Learners

Conversing: MLR5 Co-Craft Questions. Display the problem statement, "Noah bought 4 tacos and paid \$6.", without revealing the questions that follow. Invite students to discuss possible mathematical questions they could ask about this situation. Listen for questions that ask about the price for one taco, or the price of multiple tacos, and select these students to share their questions with the class. This will help draw students attention to the relationships between the two quantities in this task (number of tacos and price in dollars) prior to being asked to calculate any values.

Design Principle(s): Cultivate conversation; Support sense-making

Student Task Statement

number of tacos	price in dollars

Use the table to help you solve these problems. Explain or show your reasoning.

1. Noah bought 4 tacos and paid \$6. At this rate, how many tacos could he buy for \$15?
2. Jada's family bought 50 tacos for a party and paid \$72. Were Jada's tacos the same price as Noah's tacos?

Student Response

1. 10 tacos
2. No. Noah's tacos cost \$1.50 each. Jada's cost \$1.44 each.

Activity Synthesis

The focus should be on how students found the cost of a single taco in each situation. Be sure to remind students that dividing by a whole number is the same as multiplying by its reciprocal (a unit fraction).

12.3 Hourly Wages

10 minutes

This task introduces students to the strategy of using an equivalent ratio with one quantity having a value of 1 to find other equivalent ratios. Students look at a worked-out example of the strategy, make sense of how it works, and later apply it to solve other problems.

There are a couple of key insights to uncover here:

- The ratios we deal with do not always have corresponding quantities that are multiples of each other (e.g., in the task, 5 is not a multiple of 8, or vice versa).
- In those situations, finding an equivalent ratio where one of the quantities is 1 can be a helpful intermediate step.

Also highlighted and reinforced here is an idea students learned in Grade 5, that dividing by a whole number is equivalent to multiplying by its reciprocal (e.g., dividing by 5 is the same as multiplying by $\frac{1}{5}$).

Expect some students to initially overlook the benefit of using a ratio involving a “1,” to rely on methods from previous work, and to potentially get stuck (especially when dealing with a decimal value in the last row). For example, since the table shows an arrow and a multiplication from the first to the second row and from the second to third, students may try to do the same to find the missing value in the fourth row. While finding a factor that can be multiplied to 8 to obtain 3 is valid, encourage students to consider an alternative, given what they already know about the situation (i.e., how much the person earned in 1 hour). If needed, scaffold their thinking by asking how much Lin would earn in 2 hours and *then* in 3 hours.

Identify a student or two who can articulate why $\frac{1}{5}$ is used as a multiplier. Also notice those who can correctly reason why using a ratio with one of the values being 1 helps to find other equivalent ratios and students who reason differently. Invite these students to share later.

Addressing

- 6.RP.A.3

Instructional Routines

- Think Pair Share

Launch

This may be some students' first time reasoning about money earned by the hour. Take a minute to ensure everyone understands the concept. Ask if anyone has earned money based on the number of hours doing a job. Some students may have experience being paid by the hour for helping with house cleaning, a family business, babysitting, dog walking, or doing other jobs.

Give students quiet think time to complete the activity and a minute to share their responses (especially to the last two questions) with a partner before discussing as a class.

Support for Students with Disabilities

Representation: Internalize Comprehension. Activate background knowledge about finding equivalent ratios. Allow students to use calculators to ensure inclusive participation in the activity.

Supports accessibility for: Memory; Conceptual processing

Student Task Statement

Lin is paid \$90 for 5 hours of work. She used the table to calculate how much she would be paid at this rate for 8 hours of work.

	amount earned (\$)	time worked (hours)
$\cdot \frac{1}{5}$	90	5
	18	1
$\cdot 8$	144	8

1. What is the meaning of the 18 that appears in the table?
2. Why was the number $\frac{1}{5}$ used as a multiplier?
3. Explain how Lin used this table to solve the problem.
4. At this rate, how much would Lin be paid for 3 hours of work? For 2.1 hours of work?

Student Response

1. Lin earned \$18 for 1 hour of work or for every hour of work.

2. We wanted to turn the 5 into a 1, so the 1 could be multiplied by 8. $\frac{1}{5}$ was chosen because $5 \cdot \frac{1}{5} = 1$.
3. First, they found how much Lin made in 1 hour by multiplying both the 90 and the 5 by $\frac{1}{5}$ (or dividing them both by 5). Then, they multiplied both the 18 and the 1 by 8 to find that she earned \$144 in 8 hours.
4. Lin would be paid \$54 for 3 hours of work and \$37.80 for 2.1 hours of work.

Activity Synthesis

Select a few students to share about the use of $\frac{1}{5}$ as a multiplier and to explain the reasoning process shown in the table. If different approaches are used, take the opportunity to compare and contrast the efficacy of each.

If students had trouble reasoning to find the pay for 2.1 hours of work, help them articulate what they have done in each preceding case and urge them to think about the 2.1 the same way. If they are unsure whether multiplying 18 by 2.1 would work, encourage them to check whether the answer makes sense. (For two hours of work, Lin would earn \$36, so it stands to reason that she would earn a bit more than \$36 for 2.1 hours.) In doing so, students practice decontextualizing and contextualizing their reasoning and solutions (MP2).

12.4 Zeno's Memory Card

Optional: 15 minutes

Previously, students explored the limitation of a double number line when dealing with greatly scaled-up ratios; they saw that extending the number lines can be impractical. Here, they encounter a situation involving significantly scaled-down ratios, in which a double number line is likewise impractical (i.e., there is not enough room to fit relevant information) and see that a table is clearly preferable.

The given table deliberately includes more rows than necessary to answer the question. Some students may realize that it is not necessary to fill in all the rows if they use a different factor in finding equivalent ratios. Notice students who take such shortcuts so they can share later. Their reasoning can further highlight the flexibility of a table.

Addressing

- 6.RP.A.3

Instructional Routines

- MLR8: Discussion Supports

Launch

Open the task with a request for two volunteers and a question. Have the volunteers stand at different distances from a wall but with a clear path toward it.

Ask: “Can either student reach the wall if every time they make a move toward it, they only move half the distance between them and the wall?”

Give students a moment to think and share their predictions with a partner. Without further explanations, ask the two volunteers to begin their halfway-at-a-time journey toward the wall. When the wall is within an arm’s reach, ask the volunteers to stop. Select two students who made different predictions—one who thought it was impossible to reach the wall and one who thought otherwise—to share their reasoning. If one opinion is not represented, share the reasoning for it yourself.

Explain that the situation at hand is a famous paradox, credited to an ancient Greek philosopher, Zeno of Elea (c. ~450 BCE). Tell students: “A paradox is a situation that both cannot be true and must be true at the same time. Going halfway toward a destination is one of Zeno’s paradoxes.”

Explain that it is both impossible and possible to reach the wall by following this go-halfway procedure. Because some distance, although increasingly small, will always be left by constantly going halfway, we say it is impossible to reach the wall. But it is also obvious that the volunteers can get close enough to touch the wall, thereby “reaching” the wall.

Tell students that the next task also uses a “go halfway” process, but in a different context.

Support for Students with Disabilities

Representation: Internalize Comprehension. Activate background knowledge about using double number lines to represent ratios. Allow students to use calculators to ensure inclusive participation in the activity.

Supports accessibility for: Memory; Conceptual processing

Anticipated Misconceptions

Watch out for students being overly precise or wildly imprecise with drawing tick marks on their double number line diagram. We want them to eyeball approximately half the distance, but it would be too time-consuming to measure precisely.

Student Task Statement

In 2016, 128 gigabytes (GB) of portable computer memory cost \$32.

1. Here is a double number line that represents the situation:

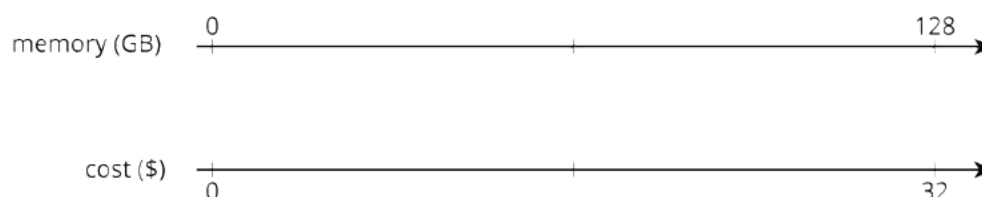

One set of tick marks has already been drawn to show the result of multiplying 128 and 32 each by $\frac{1}{2}$. Label the amount of memory and the cost for these tick marks.

Next, keep multiplying by $\frac{1}{2}$ and drawing and labeling new tick marks, until you can no longer clearly label each new tick mark with a number.

2. Here is a table that represents the situation. Find the cost of 1 gigabyte. You can use as many rows as you need.

memory (gigabytes)	cost (dollars)
128	32

3. Did you prefer the double number line or the table for solving this problem? Why?

Student Response

1. Using the double number line:

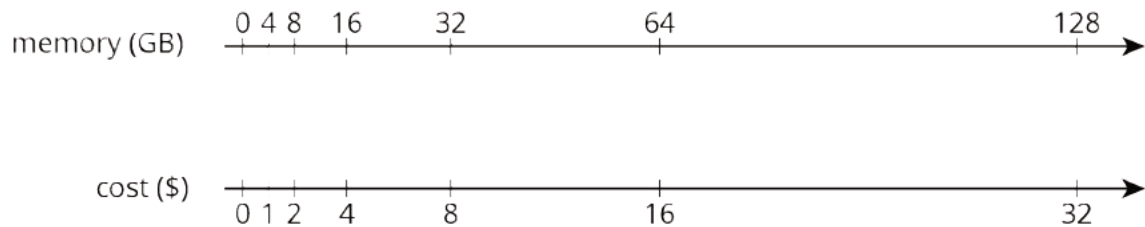

2. Using the table. Note: it's not actually necessary to write all of these rows. Bigger jumps could be made if you multiply by a number other than $\frac{1}{2}$.

memory (gigabytes)	cost (dollars)
128	32
64	16
32	8
16	4
8	2
4	1
2	0.5
1	0.25

3. Answers vary. The purpose of this question is to give students a chance to prepare for the discussion that follows.

Are You Ready for More?

A kilometer is 1,000 meters because *kilo* is a prefix that means 1,000. The prefix *mega* means 1,000,000 and *giga* (as in gigabyte) means 1,000,000,000. One byte is the amount of memory needed to store one letter of the alphabet. About how many of each of the following would fit on a 1-gigabyte flash drive?

1. letters
2. pages
3. books
4. movies
5. songs

Student Response

1. 1,000,000,000 The rest of these are estimates and are based on assumptions and averages.
2. At around 1,500 letters per page, so 1,500 bytes per page. $1,000,000,000 \div 1,500 \approx 666,667$ pages.
3. At around 250 pages per book, 375,000 bytes or 375 kilobytes.
 $1,000,000,000 \div 375,000 \approx 2,667$ books.

4. According to Google, 1 gb of data is enough for about 1 hour of video. So the flash drive would not be able to hold an entire typical movie (which is longer than 1 hour).
5. A song file is about 5 megabytes, or 5,000,000 bytes. $1,000,000,000 \div 5,000,000 = 200$ songs. (Approximately 200 songs, since the actual size of song files varies.)

Activity Synthesis

The discussion should center around why the table was easier to use for this problem: the numbers we started with were so large that there wasn't enough room to locate 1 gigabyte on the number line.

If any students multiplied the ratios by a fraction other than $\frac{1}{2}$ so that they did not have to fill all the rows, consider highlighting this shortcut. (They could even divide 128 and 32 by 128 to arrive at an answer directly, using what they have learned about unit price.) It shows how the table enables reasoning with numbers (rather than with lengths) and is more flexible.

Support for English Language Learners

Speaking, Representing: MLR8 Discussion Supports. Use this routine to support whole-class discussion. Before students discuss which representation was easier to use to find the cost of 1 gigabyte, ask students to describe how they used the double number line compared to how they used the table with a partner. If needed, provide sentence frames such as, “___ was easier to use because . . .” or “I prefer ___ because . . .” Encourage students to challenge each other when they disagree or to press for additional details when the reasoning is unclear. This will give students an opportunity to produce mathematical language to describe their reasoning about the usefulness of each representation before sharing with the whole class.

Design Principle(s): Support sense-making

Lesson Synthesis

This lesson is about using a table of equivalent ratios in an efficient way. To wrap up, highlight a few important points:

- In problems with equivalent ratios, finding an equivalent ratio containing a “1” is often a good strategy.
- To create a new row in a table of equivalent ratios, take an existing row and multiply both values by the same number.
- Remember that we can multiply whole numbers by unit fractions to get smaller numbers.

12.5 Price of Bagels

Cool Down: 5 minutes

Addressing

- 6.RP.A.3

Student Task Statement

A shop sells bagels for \$5 per dozen. You can use the table to answer the questions. Explain your reasoning.

number of bagels	price in dollars
12	5

1. At this rate, how much would 6 bagels cost?
2. How many bagels can you buy for \$50?

Student Response

1. \$2.50
2. 120 bagels

The table might look like this:

number of bagels	price in dollars
12	5
6	2.5
120	50

Student Lesson Summary

Finding a row containing a “1” is often a good way to work with tables of equivalent ratios. For example, the price for 4 lbs of granola is \$5. At that rate, what would be the price for 62 lbs of granola?

Here are tables showing two different approaches to solving this problem. Both of these approaches are correct. However, one approach is more efficient.

- Less efficient

granola (lbs)	price (\$)
4	5
8	10
16	20
32	40
64	80
62	77.50

Annotations: On the left, four arrows labeled $\cdot 2$ point from 4 to 8, 8 to 16, 16 to 32, and 32 to 64. A fifth arrow labeled $- 2 \text{ lbs}$ points from 64 to 62. On the right, four arrows labeled $\cdot 2$ point from 5 to 10, 10 to 20, 20 to 40, and 40 to 80. A fifth arrow labeled $- \$2.50$ points from 80 to 77.50.

- More efficient

granola (lbs)	price (\$)
4	5
1	1.25
62	77.50

Annotations: On the left, an arrow labeled $\cdot \frac{1}{4}$ points from 4 to 1, and an arrow labeled $\cdot 62$ points from 1 to 62. On the right, an arrow labeled $\cdot \frac{1}{4}$ points from 5 to 1.25, and an arrow labeled $\cdot 62$ points from 1.25 to 77.50.

Notice how the more efficient approach starts by finding the price for 1 lb of granola.

Remember that dividing by a whole number is the same as multiplying by a unit fraction. In this example, we can divide by 4 or multiply by $\frac{1}{4}$ to find the unit price.

Lesson 12 Practice Problems

Problem 1

Statement

Priya collected 2,400 grams of pennies in a fundraiser. Each penny has a mass of 2.5 grams. How much money did Priya raise? If you get stuck, consider using the table.

number of pennies	mass in grams
1	2.5
	2,400

Solution

\$9.60. Possible strategy:

number of pennies	mass in grams
1	2.5
1,000	2,500
4	10
40	100
960	2,400

Problem 2

Statement

Kiran reads 5 pages in 20 minutes. He spends the same amount of time per page. How long will it take him to read 11 pages? If you get stuck, consider using the table.

time in minutes	number of pages
20	5
	1
	11

Solution

44 minutes

time in minutes	number of pages
20	5
4	1
44	11

Problem 3

Statement

Mai is making personal pizzas. For 4 pizzas, she uses 10 ounces of cheese.

number of pizzas	ounces of cheese
4	10

a. How much cheese does Mai use per pizza?

b. At this rate, how much cheese will she need to make 15 pizzas?

Solution

Mai uses 2.5 ounces of cheese per pizza, because $10 \div 4 = 2.5$. She will need 37.5 ounces of cheese for 15 pizzas, because $2.5 \cdot 15 = 37.5$.

Problem 4

Statement

Clare is paid \$90 for 5 hours of work. At this rate, how many seconds does it take for her to earn 25 cents?

Solution

Clare earns 25 cents every 50 seconds. She earns \$18 per hour, and an hour has 3,600 seconds. \$18 is 72 quarters, and $3,600 \div 72 = 50$.

Problem 5

Statement

A car that travels 20 miles in $\frac{1}{2}$ hour at constant speed is traveling at the same speed as a car that travels 30 miles in $\frac{3}{4}$ hour at a constant speed. Explain or show why.

Solution

Answers vary. Sample responses:

- Both cars go 10 miles in $\frac{1}{4}$ of an hour so they are traveling at the same speed.
- In 1 hour, both cars travel 40 miles so they are both traveling at the same speed.

(From Unit 2, Lesson 10.)

Problem 6

Statement

Lin makes her favorite juice blend by mixing cranberry juice with apple juice in the ratio shown on the double number line. Complete the diagram to show smaller and larger batches that would taste the same as Lin's favorite blend.

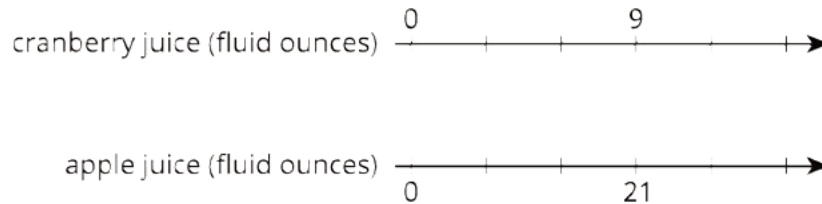

Solution

Cranberry (cups): 0, 3, 6, 9, 12, 15. Apple (cups): 0, 7, 14, 21, 28, 35

(From Unit 2, Lesson 6.)

Problem 7

Statement

Each of these is a pair of equivalent ratios. For each pair, explain why they are equivalent ratios or draw a representation that shows why they are equivalent ratios.

- 600 : 450 and 60 : 45
- 60 : 45 and 4 : 3
- 600 : 450 and 4 : 3

Solution

Answers vary. Sample response:

- $60 \cdot 10 = 600$ and $45 \cdot 10 = 450$.
- Multiplying 4 and 3 by 15 gives 60 and 45.
- Multiply 4 by 150 to get 600 and multiply 3 by 150 to get 450. Or use problems 4 and 5 together: problem 4 shows that $600 : 450$ is equivalent to $60 : 45$ and problem 5 shows that $60 : 45$ is equivalent to $4 : 3$. This means that $600 : 450$ is equivalent to $4 : 3$.

(From Unit 2, Lesson 5.)

Lesson 13: Tables and Double Number Line Diagrams

Goals

- Compare and contrast (orally) double number line diagrams and tables representing the same situation.
- Draw and label a table of equivalent ratios from scratch to solve problems about constant speed.

Learning Targets

- I can create a table that represents a set of equivalent ratios.
- I can explain why sometimes a table is easier to use than a double number line to solve problems involving equivalent ratios.
- I include column labels when I create a table, so that the meaning of the numbers is clear.

Lesson Narrative

In this lesson, students explicitly connect and contrast double number lines and tables. They also encounter a problem involving relatively small fractions, so the flexibility of a table makes it preferable to a double number line. Students have used tables in earlier grades to identify arithmetic patterns and record measurement equivalents. In grade 6, a new feature of working with tables is considering the relationship between values in different rows. Two features of tables make them more flexible than double number lines:

- On a double number line, differences between numbers are represented by lengths on each number line. While this feature can help support reasoning about relative sizes, it can be a limitation when large or small numbers are involved, which may consequently hinder problem solving. A table removes this limitation because differences between numbers are no longer represented by the geometry of a number line.
- A double number line dictates the ordering of the values on the line, but in a table, pairs of values can be written in any order. 5 pounds of coffee cost \$40. How much does 8.5 pounds cost? You can see in the table below how being able to skip around makes for more nimble problem solving:

weight of coffee (pounds)	cost (dollars)
5	40
1	8
8.5	68

At this point in the unit, students should have a strong sense of what it means for two ratios to be equivalent, so they can fill in a table of equivalent ratios with understanding instead of just by following a procedure. Students can also always fall back to other representations if needed.

Alignments

Building On

- 5.NBT: Grade 5 - Number and Operations in Base Ten

Addressing

- 6.RP.A.3: Use ratio and rate reasoning to solve real-world and mathematical problems, e.g., by reasoning about tables of equivalent ratios, tape diagrams, double number line diagrams, or equations.
- 6.RP.A.3.a: Make tables of equivalent ratios relating quantities with whole-number measurements, find missing values in the tables, and plot the pairs of values on the coordinate plane. Use tables to compare ratios.

Instructional Routines

- Anticipate, Monitor, Select, Sequence, Connect
- MLR8: Discussion Supports
- Number Talk

Required Materials

Pre-printed slips, cut from copies of the **blackline master**

Required Preparation

Make 1 copy of the The International Space Station blackline master for every 4 students, and cut them up ahead of time.

Student Learning Goals

Let's contrast double number lines and tables.

13.1 Number Talk: Constant Dividend

Warm Up: 10 minutes

This number talk helps students think about what happens to a quotient when the divisor is doubled. In this lesson and in upcoming work on ratios and unit rates, students will be asked to find a fraction of a number and identify fractions on a number line.

Building On

- 5.NBT

Instructional Routines

- MLR8: Discussion Supports
- Number Talk

Launch

Display one problem at a time. Tell students to give a signal when they have an answer and a strategy. After each problem, give students 1 minute of quiet think time followed by a whole-class discussion. Pause after discussing the third question and give students 1 minute of quiet think time to place the quotients on the number line.

Support for Students with Disabilities

Representation: Internalize Comprehension. To support working memory, provide students with sticky notes or mini whiteboards.

Supports accessibility for: Memory; Organization

Student Task Statement

Find the quotients mentally.

$$150 \div 2$$

$$150 \div 4$$

$$150 \div 8$$

Locate and label the quotients on the number line.



Student Response

- - $150 \div 2 = 75$. Possible strategies: $2 \cdot 75 = 150$, $(100 \div 2) + (50 \div 2) = 75$.
 - $150 \div 4 = 37.5$. Possible strategies: $75 \div 2 = 37.5$ from the previous question, $(148 \div 4) + (2 \div 4) = 37.5$.
 - $150 \div 8 = 18.75$. Possible strategies: $37.5 \div 2 = 18.75$ from the previous question, $144 \div 8 + 6 \div 8 = 18.75$.
- Here is the number line:

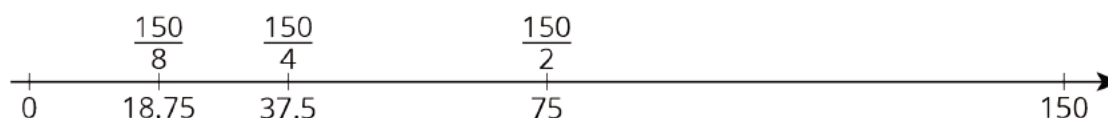

Activity Synthesis

Ask students to share their strategies for each problem. Record and display their explanations for all to see. To involve more students in the conversation, consider asking:

- “Who can restate ___’s reasoning in a different way?”
- “Did anyone solve the problem the same way but would explain it differently?”
- “Did anyone solve the problem in a different way?”
- “Does anyone want to add on to ____’s strategy?”
- “Do you agree or disagree? Why?”

For the fourth question, display the number line for all to see and invite a few students to share their reasoning about the location of each quotient on the number line. Discuss students’ observations from when they placed the numbers on the number line.

Support for English Language Learners

Speaking: MLR8 Discussion Supports.: Display sentence frames to support students when they explain their strategy. For example, “First, I ___ because . . .” or “I noticed ___ so I . . .” Some students may benefit from the opportunity to rehearse what they will say with a partner before they share with the whole class.

Design Principle(s): Optimize output (for explanation)

13.2 Moving 3,000 Meters

15 minutes

In this activity, students use tables of equivalent ratios to solve three problems, with decreasing scaffolding throughout the activity. For the first problem, students start by examining a table of equivalent ratios, noticing that descriptive column headers are important in helping you use a table of equivalent ratios to solve a problem. For the second problem, there is an empty table students can fill in. The third problem does not provide any scaffolding, allowing students to choose their own method of solving the problem.

Monitor for students solving the last problem in different ways.

Addressing

- 6.RP.A.3.a

Instructional Routines

- Anticipate, Monitor, Select, Sequence, Connect
- MLR8: Discussion Supports

Launch

Arrange students in groups of 2. Give 3 minutes of quiet work time and then have students work with their partner.

Student Task Statement

The other day, we saw that Han can run 100 meters in 20 seconds.

Han wonders how long it would take him to run 3,000 meters at this rate. He made a table of equivalent ratios.

1. Do you agree that this table represents the situation? Explain your reasoning.

20	100
10	50
1	5
3,000	

2. Complete the last row with the missing number.
3. What question about the situation does this number answer?
4. What could Han do to improve his table?
5. Priya can bike 150 meters in 20 seconds. At this rate, how long would it take her to bike 3,000 meters?

6. Priya's neighbor has a dirt bike that can go 360 meters in 15 seconds. At this rate, how long would it take them to ride 3,000 meters?

Student Response

1. Answers vary. Sample response: I agree with the first three rows, but the last row would be for 3,000 seconds instead of 3,000 meters, so it wouldn't help Han answer the question.
2. The empty cell should contain 15,000.
3. How far he would go in 3,000 seconds.
4. He should label what quantities are in each column.
5. 400 seconds
6. 125 seconds

Activity Synthesis

Select students with different methods for the last question to explain their solutions to the class. Highlight the connections between different strategies, especially between tables and double number line diagrams.

Support for English Language Learners

Speaking, Listening: MLR8 Discussion Supports. Use this routine to support whole-class discussion. For each method that is shared, ask students to restate what they heard using precise mathematical language. Consider providing students time to restate what they heard to a partner before selecting one or two students to share with the class. Ask the original speaker if their peer was accurately able to restate their thinking. Call students' attention to any words or phrases that helped to clarify the original statement. This provides more students with an opportunity to produce language as they interpret the reasoning of others.

Design Principle(s): Support sense-making

13.3 The International Space Station

15 minutes

This activity prompts students to compare and contrast two representations of equivalent ratios. Students work collaboratively to observe similarities and differences of using a double number line and using a table to express the same situation. Below are some key distinctions:

double number line	table
Distances between numbers and lengths of lines matter.	Distances and lengths do not matter because there are no lines.
The numbers on each line must be in order.	Rows of ratios can be out of order; within a column, numbers can go in any order that is convenient.
Each value of a ratio is shown on a line.	Each value of a ratio is shown in a column.
Pairs of values of a ratio are aligned vertically.	Pairs of values of a ratio appear in the same row.

You will need The International Space Station blackline master for this activity.

Addressing

- 6.RP.A.3.a

Launch

To help students build some intuition about kilometers, begin by connecting it with contexts that are familiar to them. Tell students that “kilometer” is a unit used in the problem. Then ask a few guiding questions.

- “Can you name two things in our town (or city) that are about 1 kilometer apart?” (Consider finding some examples of 1-kilometer distances near your school ahead of time.)
- “How long do you think it would take you to walk 1 kilometer?” (Typical human walking speed is about 5 kilometers per hour, so it takes a person about 12 minutes to walk 1 kilometer.)
- “What might be a typical speed limit on a highway, in kilometers per hour?” (100 kilometers per hour is a typical highway speed limit. Students might be more familiar with a speed limit such as 65 miles per hour. Since there are about 1.6 kilometers in every mile, the same speed will be expressed as a higher number in kilometers per hour than in miles per hour.)

Arrange students in groups of 2. Give one person a slip with the table and the other a slip with a double number line (shown below). Ask students to first do what they can independently, and then to obtain information from their partners to fill in all the blanks. Explain that when the blanks are filled, the two representations will show the same information.

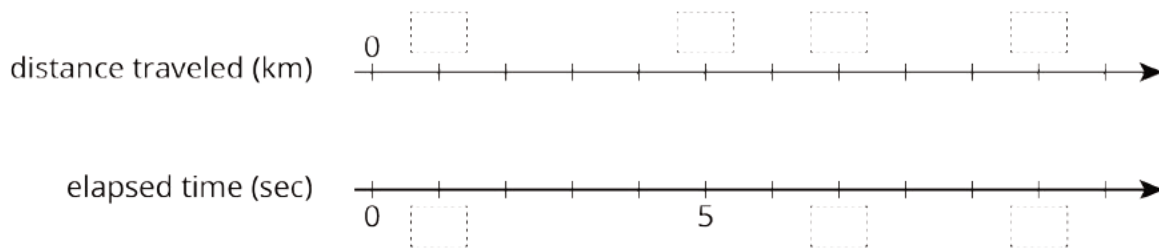

distance traveled (km)	elapsed time (sec)
0	0
80	10
	1

Anticipated Misconceptions

Students with the double number line representation may decide to label every tick mark instead of just the ones indicated with dotted rectangles. This is fine. Make sure they understand that the tick marks with dotted rectangles are the ones they are supposed to record in the table.

Student Task Statement

The International Space Station orbits around the Earth at a constant speed. Your teacher will give you either a double number line or a table that represents this situation. Your partner will get the other representation.



1. Complete the parts of your representation that you can figure out for sure.
2. Share information with your partner, and use the information that your partner shares to complete your representation.
3. What is the speed of the International Space Station?
4. Place the two completed representations side by side. Discuss with your partner some ways in which they are the same and some ways in which they are different.

5. Record at least one way that they are the same and one way they are different.

Student Response

distance traveled (kilometers)	elapsed time (seconds)
0	0
80	10
8	1
40	5
56	7

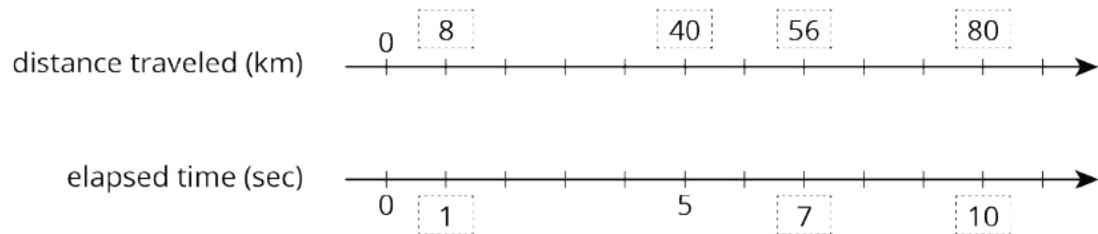

1. See table and double number line.
2. See table and double number line.
3. The ISS is traveling in its orbit at a speed of 8 kilometers per second. You can see this because both representations show the distance traveled in 1 second.
4. Answers vary; see Classroom Activity Synthesis.
5. See Classroom Activity Synthesis.

Are You Ready for More?

Earth's circumference is about 40,000 kilometers and the orbit of the International Space Station is just a bit more than this. About how long does it take for the International Space Station to orbit Earth?

Student Response

Between 80 and 100 minutes.

Earth's circumference is about 40,000 kilometers. The orbit of the International Space Station is longer than this, but not a lot longer. The orbit will take a little more than $40,000 \div 8 = 5,000$ seconds. 80 minutes is 4,800 seconds, and 100 minutes is 6,000 seconds.

Activity Synthesis

Display completed versions of both representations for all to see. Invite students to share the ways the representations are alike and different. Consider writing some of these on the board, or this could just be a verbal discussion. Highlight the distinctions in terms of distances between numbers, order of numbers, and the vertical or horizontal orientations of the representations.

Although it is not a structural distinction, students might describe the direction in which multiplying happens as a difference between the two representations. They might say that we “multiply up or down” to find equivalent ratios in a table, and we “multiply across” to do the same on a double number line. You could draw arrows to illustrate this fact:

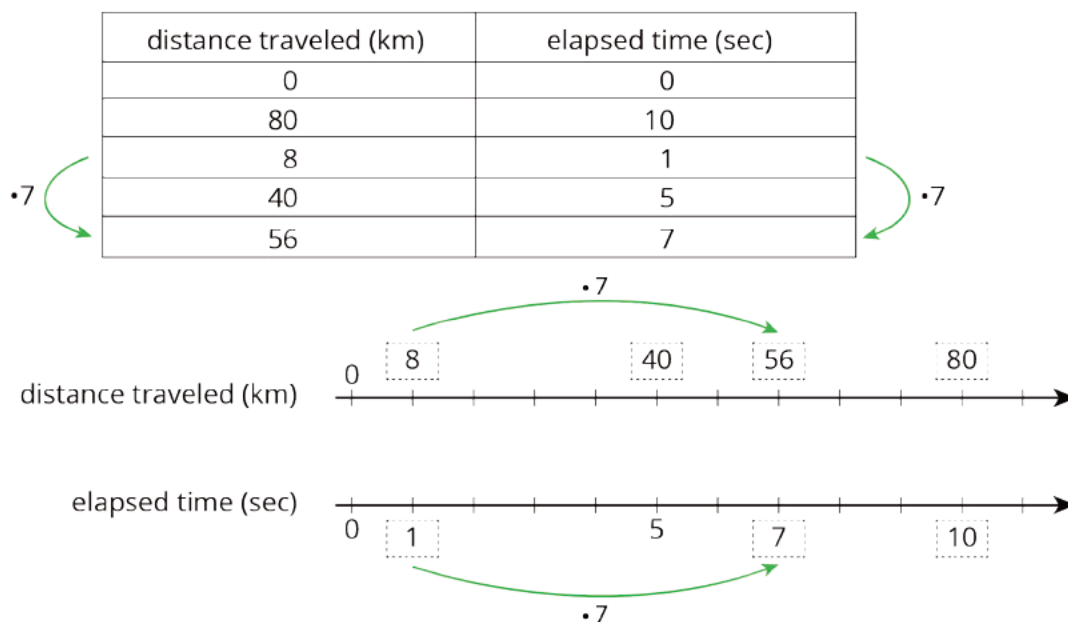

The vertical orientation of tables and the horizontal orientation of double number lines are conventions we decided to consistently use in these materials. Mathematically, there is nothing wrong with orienting each representation the other way. Students may encounter tables oriented horizontally in a later course. Later in this course, they will encounter number lines oriented vertically.

Support for Students with Disabilities

Representation: Internalize Comprehension. Demonstrate and encourage students to use color coding and annotations to highlight connections between representations in a problem. For example, highlight the distinctions in terms of distances between numbers, order of numbers, and the vertical or horizontal orientations of the representations.

Supports accessibility for: Conceptual processing; Organization

Lesson Synthesis

Briefly revisit the two tasks, displaying the representations for all to see, and pointing out ways in which tables and double number lines are the same and different. Emphasize that tables are sometimes easier to work with.

- In one task, we looked at the distance the ISS travels in its orbit and the time it takes to orbit Earth. How are the table and the double number line similar to each other? How are they different?
- Why is it important to include descriptive column headers on tables?

13.4 Bicycle Sprint

Cool Down: 5 minutes

Addressing

- 6.RP.A.3

Student Task Statement

In a sprint to the finish, a professional cyclist travels 380 meters in 20 seconds. At that rate, how far does the cyclist travel in 3 seconds?

Student Response

They travel 57 meters in 3 seconds. Possible strategy:

distance traveled (meters)	elapsed time (seconds)
380	20
19	1
57	3

Student Lesson Summary

On a double number line diagram, we put labels in front of each line to tell what the numbers represent. On a table, we put labels at the top of each column to tell what the numbers represent.

Here are two different ways we can represent the situation: "A snail is moving at a constant speed down a sidewalk, traveling 6 centimeters per minute."

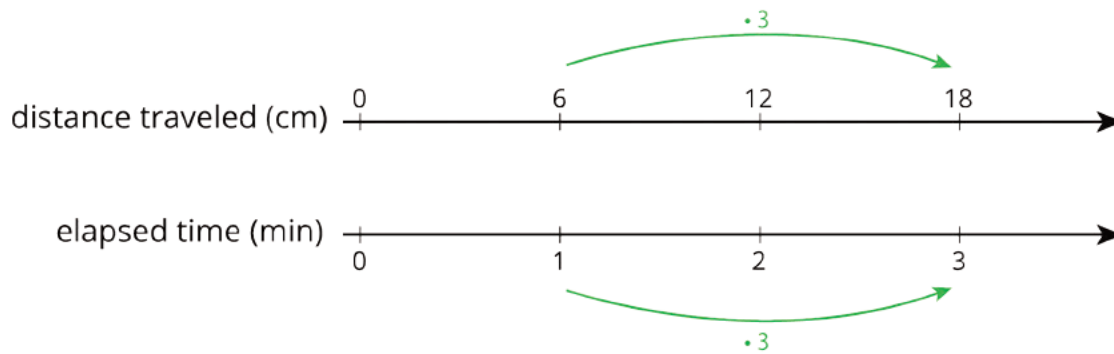

distance traveled (cm)	elapsed time (min)
12	2
6	1
60	10
18	3

Both double number lines and tables can help us use multiplication to make equivalent ratios, but there is an important difference between the two representations.

On a double number line, the numbers on each line are listed in order. With a table, you can write the ratios in any order. For this reason, sometimes a table is easier to use to solve a problem.

For example, what if we wanted to know how far the snail travels in 10 minutes? Notice that 60 centimeters in 10 minutes is shown on the table, but there is not enough room for this information on the double number line.

Lesson 13 Practice Problems

Problem 1

Statement

The double number line shows how much water and how much lemonade powder to mix to make different amounts of lemonade.

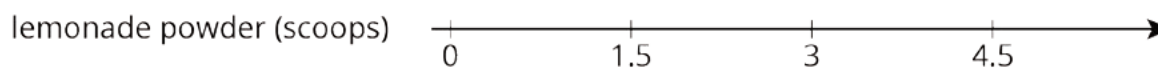

Make a table that represents the same situation.

Solution

water (cups)	lemonade powder (scoops)
0	0
2	1.5
4	3
6	4.5

Problem 2

Statement

A bread recipe uses 3 tablespoons of olive oil for every 2 cloves of crushed garlic.

- Complete the table to show different-sized batches of bread that taste the same as the recipe.
- Draw a double number line that represents the same situation.
- Which representation do you think works better in this situation? Explain why.

olive oil (tablespoons)	crushed garlic (cloves)
3	2
1	
2	
5	
10	

Solution

a.

olive oil (tablespoons)	crushed garlic (cloves)
3	2
1	$\frac{2}{3}$
2	$1\frac{1}{3}$
5	$3\frac{1}{3}$
10	$6\frac{2}{3}$

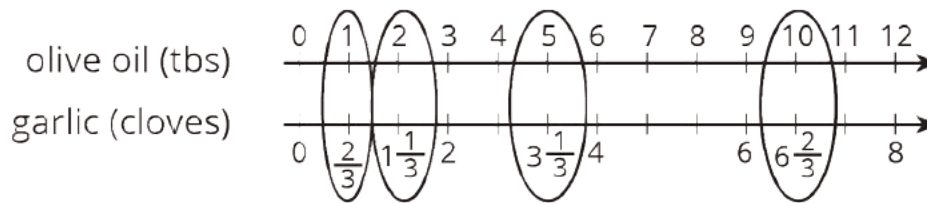

b.

c. Answers vary. Sample response: The table is more convenient because the rows of the table can be listed in any order and without worrying about placing numbers accurately on the number line.

Problem 3

Statement

Clare travels at a constant speed, as shown on the double number line.

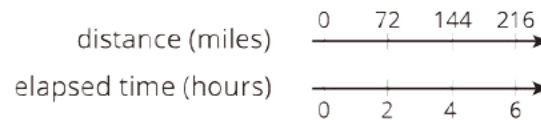

At this rate, how far does she travel in each of these intervals of time? Explain or show your reasoning. If you get stuck, consider using a table.

- a. 1 hour
- b. 3 hours
- c. 6.5 hours

Solution

Explanations vary. Sample responses:

- a. 36 miles. 1 hour is half of 2 hours, so half of 72 is 36. She traveled 36 miles in 1 hour.
- b. 108 miles. Since the rate is 36 miles per hour, to find her distance in 3 hours, multiply 36 by 3. She traveled 108 miles in 3 hours.
- c. 234 miles. Multiply the rate by 6.5. She traveled 234 miles in 6.5 hours.

distance (miles)	elapsed time (hours)
72	2
36	1
108	3
234	6.5

Problem 4

Statement

Lin and Diego travel in cars on the highway at constant speeds. In each case, decide who was traveling faster and explain how you know.

- During the first half hour, Lin travels 23 miles while Diego travels 25 miles.
- After stopping for lunch, they travel at different speeds. To travel the next 60 miles, it takes Lin 65 minutes and it takes Diego 70 minutes.

Solution

Explanations vary. Sample response:

- Diego traveled faster because he covered more distance than Lin in the same amount of time.
- Lin traveled faster because she covered the same distance as Diego but in less time.

(From Unit 2, Lesson 9.)

Problem 5

Statement

A sports drink recipe calls for $\frac{5}{3}$ tablespoons of powdered drink mix for every 12 ounces of water. How many batches can you make with 5 tablespoons of drink mix and 36 ounces of water? Explain your reasoning.

Solution

3 batches. Each batch has $\frac{5}{3}$ tablespoons of drink mix, so 3 batches will have 5 tablespoons of drink mix, since $3 \cdot \frac{5}{3} = 5$. Similarly, we can make 3 batches with 36 ounces of water, since $3 \cdot 12 = 36$.

(From Unit 2, Lesson 3.)

Problem 6

Statement

In this cube, each small square has side length 1 unit.

- What is the surface area of this cube?
- What is the volume of this cube?

Solution

- 54 square units

b. 27 cubic units

(From Unit 1, Lesson 18.)

Lesson 14: Solving Equivalent Ratio Problems

Goals

- Determine what information is needed to solve a problem involving equivalent ratios. Ask questions to elicit that information.
- Understand the structure of a what-why info gap activity.

Learning Targets

- I can decide what information I need to know to be able to solve problems about situations happening at the same rate.
- I can explain my reasoning using diagrams that I choose.

Lesson Narrative

The purpose of this lesson is to give students further practice in solving equivalent ratio problems and introduce them to the info gap activity structure. The info gap structure requires students to make sense of problems by determining what information is necessary, and then to ask for information they need to solve it. This may take several rounds of discussion if their first requests do not yield the information they need (MP1). It also allows them to refine the language they use and ask increasingly more precise questions until they get the information they need (MP6).

Alignments

Addressing

- 6.RP.A.3: Use ratio and rate reasoning to solve real-world and mathematical problems, e.g., by reasoning about tables of equivalent ratios, tape diagrams, double number line diagrams, or equations.

Instructional Routines

- Anticipate, Monitor, Select, Sequence, Connect
- MLR4: Information Gap Cards
- MLR5: Co-Craft Questions
- Think Pair Share

Required Materials

Pre-printed slips, cut from copies of the blackline master

Required Preparation

You will need the Hot Chocolate and Potatoes Info Gap blackline master for this lesson. Make 1 copy for every 4 students, and cut them up ahead of time.

Student Learning Goals

Let's practice getting information from our partner.

14.1 What Do You Want to Know?

Warm Up: 5 minutes

The warm-up prepares students for the next info gap activity by first asking them to brainstorm what information they would need to know to solve an equivalent ratio problem. Next, the teacher demonstrate asking students to share what they want to know and why they want to know it before giving them the information.

Addressing

- 6.RP.A.3

Launch

Give students 2 minutes of quiet think time.

Student Task Statement

Consider the problem: A red car and a blue car enter the highway at the same time and travel at a constant speed. How far apart are they after 4 hours?

What information would you need to be able to solve the problem?

Student Response

Answers vary. Sample responses:

- How fast is each car traveling?
- Are the cars going the same direction?
- Did the cars enter the highway at the same location?
- What is the difference between the speeds of the two cars?

Activity Synthesis

Demonstrate asking students the questions they will use in the Info Gap in the next activity. Ask them, "What specific information do you need?" As students pose questions, write them down and ask, "Why do you need that information?"

When students explain why they need the information, provide it to them. After sharing each piece of information, ask the class whether they have enough information to solve the problem. When they think they do, give them 2 minutes to solve the problem and then have them share their strategies.

- The red car is traveling faster than the blue car.
- One car is traveling 5 miles per hour faster than the other car.

- The slower car is traveling at 60 miles per hour.
- The blue car is traveling at 60 miles per hour.
- The faster car is traveling at 65 miles per hour.
- The red car is traveling as 65 miles per hour.
- Both cars entered the highway at the same location.
- Both cars are traveling in the same direction.

14.2 Info Gap: Hot Chocolate and Potatoes

30 minutes

In this info gap activity, students solve problems involving equivalent ratios. If students use a table, it may take different forms. Some students may produce a table that has many rows that require repeated multiplication. Others may create a more abbreviated table and use more efficient multipliers. Though some approaches may be more direct or efficient than others, it is important for students to choose their own method for solving them, and to explain their method so that their partner can understand (MP3).

The info gap structure requires students to make sense of problems by determining what information is necessary, and then to ask for information they need to solve it. This may take several rounds of discussion if their first requests do not yield the information they need (MP1). It also allows them to refine the language they use and ask increasingly more precise questions until they get the information they need (MP6).

Here is the text of the cards for reference and planning:

Problem Card 1

Jada mixes milk and cocoa powder to make hot chocolate. She wants to use all the cocoa powder she has left. How much milk should Jada use?

Data Card 1

- One batch of Jada's recipe calls for 3 cups of milk.
- One batch of Jada's recipe calls for 2 tablespoons of cocoa powder.
- Jada has 2 gallons of milk left.
- Jada has 9 tablespoons of cocoa powder left.
- There are 16 cups in 1 gallon.

Problem Card 2

Noah needs to peel a lot of potatoes before a dinner party. He has already peeled some potatoes. If he keeps peeling at the same rate, will he finish all the potatoes in time?

Data Card 2

- Noah has already been peeling potatoes for 10 minutes.
- Noah has already peeled 8 potatoes.
- Noah needs to peel 60 more potatoes.
- Noah needs to be finished peeling potatoes in 1 hour and 10 minutes.
- There are 60 minutes in 1 hour.

Addressing

- 6.RP.A.3

Instructional Routines

- MLR4: Information Gap Cards

Launch

Arrange students in groups of 2. In each group, distribute a problem card to one student and a data card to the other student.

Support for Students with Disabilities

Action and Expression: Internalize Executive Functions. Begin with a small-group or whole-class demonstration and think aloud of a sample situation to remind students how to use the info gap structure. Keep the worked-out table and double number lines on display for students to reference as they work.

Supports accessibility for: Memory; Conceptual processing

Support for English Language Learners

Conversing: This activity uses MLR4 Information Gap to give students a purpose for discussing information necessary to solve problems involving equivalent ratios. Display questions or question starters for students who need a starting point such as: “Can you tell me . . . (specific piece of information)”, and “Why do you need to know . . . (that piece of information)?”

Design Principle(s): Cultivate Conversation

Anticipated Misconceptions

Students may misinterpret the meaning of the numbers or associate quantities incorrectly and multiply 8 by 6 (because $10 \cdot 6$ is 60). Encourage them to organize the given information in a table or a double number line.

Student Task Statement

Your teacher will give you either a *problem card* or a *data card*. Do not show or read your card to your partner.

If your teacher gives you the *problem card*:

1. Silently read your card and think about what information you need to be able to answer the question.
2. Ask your partner for the specific information that you need.
3. Explain how you are using the information to solve the problem.

Continue to ask questions until you have enough information to solve the problem.

4. Share the *problem card* and solve the problem independently.
5. Read the *data card* and discuss your reasoning.

If your teacher gives you the *data card*:

1. Silently read your card.
2. Ask your partner “*What specific information do you need?*” and wait for them to *ask* for information.

If your partner asks for information that is not on the card, do not do the calculations for them. Tell them you don’t have that information.

3. Before sharing the information, ask “*Why do you need that information?*” Listen to your partner’s reasoning and ask clarifying questions.
4. Read the *problem card* and solve the problem independently.
5. Share the *data card* and discuss your reasoning.

Pause here so your teacher can review your work. Ask your teacher for a new set of cards and repeat the activity, trading roles with your partner.

Student Response

Jada should use 13.5 cups of milk. Possible strategies:

- Finding a multiplier that relates 2 to 9 tablespoons of cocoa. They may ask “2 times what is 9?” and use 4.5 as the factor to multiply by 3.
- Multiplying the number of cups of milk by 9 to correspond to 18 tablespoons of cocoa, and then dividing it by 2 for 9 tablespoons of cocoa.
- Multiplying by $\frac{1}{2}$ (or dividing by 2) to find the number of cups of milk that correspond to 1 tablespoon of cocoa, and then multiplying that number by 9 for 9 tablespoons of cocoa, as shown in the table below.

milk (cups)	cocoa (tablespoons)
3	2
$\frac{3}{2}$ or 1.5	1
$13\frac{1}{2}$ or 13.5	9

No, Noah does not have enough time. It will take him 75 minutes to finish peeling all the potatoes. Possible strategies:

elapsed time (minutes)	potatoes peeled
10	8
$\frac{10}{8}$, $\frac{5}{4}$, or 1.25	1
75	60
1	$\frac{8}{10}$, $\frac{4}{5}$, or 0.8
25	20
70	56

1. It will take 75 minutes to peel 60 potatoes (1.25 minutes per potato).
2. He could peel 56 potatoes in 70 minutes (0.8 potatoes per minute).

Activity Synthesis

Select one student to explain each distinct approach. Highlight how multiplicative reasoning and using the table are similar or different in each case.

When all approaches have been discussed, ask students: “When might it be helpful to first find the amount that corresponds to 1 unit of one quantity and scale that amount up to any value we want?” Encourage students to refer to all examples seen in this lesson so far.

14.3 Comparing Reading Rates

Optional: 10 minutes

This activity provides an opportunity for additional practice in solving equivalent ratio problems. Monitor for students solving the problems in different ways.

Addressing

- 6.RP.A.3

Instructional Routines

- Anticipate, Monitor, Select, Sequence, Connect
- MLR5: Co-Craft Questions
- Think Pair Share

Launch

Give students 4 minutes of quiet work time and then have them discuss their solutions with a partner.

Support for Students with Disabilities

Representation: Internalize Comprehension. Activate or supply background knowledge about equivalent ratios describing situations that happen at the same rate which can be displayed on double number lines. Allow students to use calculators to ensure inclusive participation in the activity.

Supports accessibility for: Memory; Conceptual processing

Support for English Language Learners

Writing: MLR5 Co-Craft Questions. Before asking students to solve the given question, display only Lin's, Diego's and Elena's reading rates. Invite students think of possible mathematical questions about this situation. Keep in mind students do not need to answer their created questions. Students share and revise their questions with a partner and then with the whole class. Record questions shared with the class in a public space. This helps students connect mathematical language to get into the context of the problem as they reason about the three different quantities (i.e., number of pages read, number of pages in the book, and number of days reading).

Design Principle(s): Maximize meta-awareness

Student Task Statement

- Lin read the first 54 pages from a 270-page book in the last 3 days.
- Diego read the first 100 pages from a 320-page book in the last 4 days.
- Elena read the first 160 pages from a 480-page book in the last 5 days.

If they continue to read every day at these rates, who will finish first, second, and third? Explain or show your reasoning.

Student Response

First: Diego, Second: Elena, Third: Lin

Possible Strategy:

- Diego

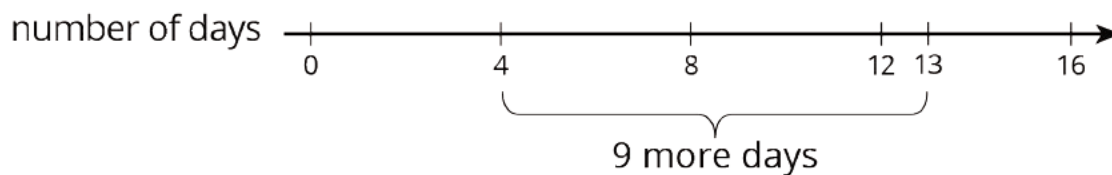
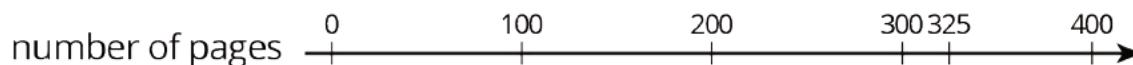

- Elena

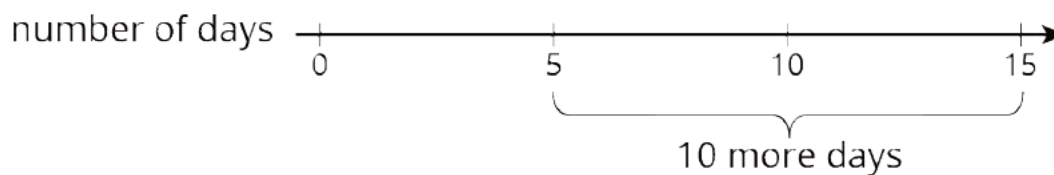
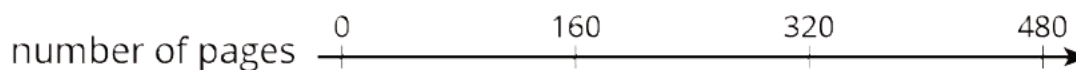

- Lin

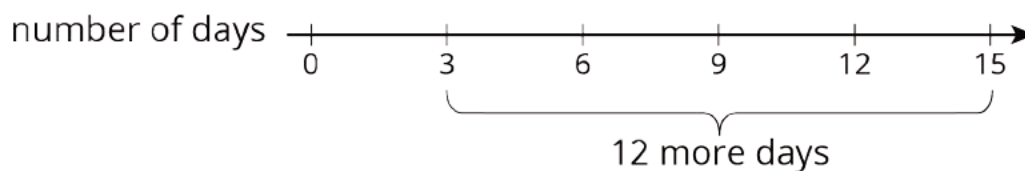

Are You Ready for More?

The ratio of cats to dogs in a room is $2 : 3$. Five more cats enter the room, and then the ratio of cats to dogs is $9 : 11$. How many cats and dogs were in the room to begin with?

Student Response

22 cats and 33 dogs

Activity Synthesis

Select students to present their solutions. Sequence solutions with diagrams first and then tables. Make sure students see connections between the different representations and ways of solving the problems.

Lesson Synthesis

When solving problems involving equivalent ratios, we often have three pieces of information and need to find a fourth. For example:

- If you eat 12 strawberries in 3 minutes, how long will it take to eat 8 strawberries at that rate?

We can use a table to solve this problem very quickly. For example:

number of strawberries	number of minutes
12	3
1	$\frac{1}{4}$
8	2

- If you jump 8 times in 10 seconds, how many jumps can you make in 45 seconds at that rate?

Where would you put the one in this table? What is the answer to the question?

number of jumps	number of seconds
8	10

14.4 Water Faucet

Cool Down: 5 minutes

Addressing

- 6.RP.A.3

Student Task Statement

Jada wants to know how fast the water comes out of her faucet. What information would she need to know to be able to determine that?

Student Response

Answers vary. Sample response: She would need to know how much water comes out in some amount of time.

For example, she could time how long it takes to fill up some container that she knows the size of.

Student Lesson Summary

To solve problems about something happening at the same rate, we often need:

- Two pieces of information that allow us to write a ratio that describes the situation.
- A third piece of information that gives us one number of an equivalent ratio. Solving the problem often involves finding the other number in the equivalent ratio.

Suppose we are making a large batch of fizzy juice and the recipe says, “Mix 5 cups of cranberry juice with 2 cups of soda water.” We know that the ratio of cranberry juice to soda water is $5 : 2$, and that we need 2.5 cups of cranberry juice per cup of soda water.

We still need to know something about the size of the large batch. If we use 16 cups of soda water, what number goes with 16 to make a ratio that is equivalent to $5 : 2$?

To make this large batch taste the same as the original recipe, we would need to use 40 cups of cranberry juice.

cranberry juice (cups)	soda water (cups)
5	2
2.5	1
40	16

Lesson 14 Practice Problems

Problem 1

Statement

A chef is making pickles. He needs 15 gallons of vinegar. The store sells 2 gallons of vinegar for \$3.00 and allows customers to buy any amount of vinegar. Decide whether each of the following ratios correctly represents the price of vinegar.

- 4 gallons to \$3.00
- 1 gallon to \$1.50
- 30 gallons to \$45.00
- \$2.00 to 30 gallons
- \$1.00 to $\frac{2}{3}$ gallon

Solution

- a. No. (The ratio is not equivalent; 4 gallons of vinegar would cost \$6).
- b. Yes.
- c. Yes.
- d. No. (The ratio is not equivalent; 2 gallons of vinegar cost \$3, and \$30 would buy 20 gallons).
- e. Yes.

Problem 2

Statement

A caterer needs to buy 21 pounds of pasta to cater a wedding. At a local store, 8 pounds of pasta cost \$12. How much will the caterer pay for the pasta there?

- a. Write a ratio for the given information about the cost of pasta.
- b. Would it be more helpful to write an equivalent ratio with 1 pound of pasta as one of the numbers, or with \$1 as one of the numbers? Explain your reasoning, and then write that equivalent ratio.
- c. Find the answer and explain or show your reasoning.

Solution

- a. Answers vary. Sample responses: \$12 for every 8 pounds; \$12 to 8 pounds; 8 pounds to \$12.
- b. Answers vary. Sample response: Finding 1 pound would be easier and more helpful. The cost of 1 pound can be easily found by dividing \$12 by 8 and the result (the unit rate) can be multiplied by 21. The ratio is \$1.50 to 1 pound.
- c. \$31.50. Possible reasonings: $21 \cdot (1.50) = 31.50$.

pasta (pounds)	cost (dollars)
8	12
1	1.50
21	31.50

Problem 3

Statement

Lin is reading a 47-page book. She read the first 20 pages in 35 minutes.

- a. If she continues to read at the same rate, will she be able to complete this book in under 1 hour?
- b. If so, how much time will she have left? If not, how much more time is needed? Explain or show your reasoning.

Solution

No, it will take Lin 82.25 minutes to finish her book. Possible strategies:

- a. Using a table:

number of pages	times in minutes
20	35
1	1.75 (or equivalent)
47	82.25 (or equivalent)

Additional 22.25 or $22\frac{1}{4}$ minutes (or 22 minutes and 15 seconds) are needed.

- b. 40 pages will take 70 minutes, which is already more than an hour, so Lin can not finish the 47-page book in an hour.

Problem 4

Statement

Diego can type 140 words in 4 minutes.

- a. At this rate, how long will it take him to type 385 words?
- b. How many words can he type in 15 minutes?

If you get stuck, consider creating a table.

Solution

Answers vary. Sample response:

number of words	number of minutes
140	4
1	$\frac{1}{35}$
385	11
35	1
525	15

- It will take 11 minutes to type 385 words.
- He can type 525 words in 15 minutes.

Problem 5

Statement

A train that travels 30 miles in $\frac{1}{3}$ hour at a constant speed is going faster than a train that travels 20 miles in $\frac{1}{2}$ hour at a constant speed. Explain or show why.

Solution

Answers vary. Sample responses:

- In 1 hour, the first train will travel 90 miles, while the second train only travels 40 miles. The first train is going faster.
- The train traveling 30 miles in $\frac{1}{3}$ of an hour takes $\frac{1}{9}$ of an hour to go 10 miles. The train traveling 20 miles in $\frac{1}{2}$ of an hour takes $\frac{1}{4}$ of an hour to go 10 miles. This means that the first train is traveling faster.

(From Unit 2, Lesson 10.)

Problem 6

Statement

Find the surface area of the polyhedron that can be assembled from this net. Show your reasoning.

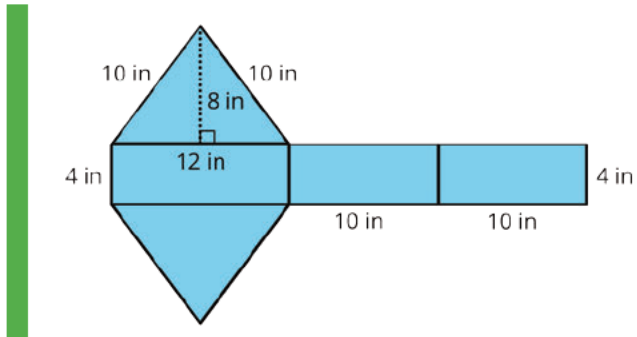

Solution

224 square inches. Reasoning varies. Sample reasoning: The three rectangular faces have areas 48, 40, and 40 square inches. Each triangle has a base of 12 inches and a height of 8 inches, so each triangle has an area of 48 square inches. $48 + 40 + 40 + 2(48) = 224$.

(From Unit 1, Lesson 14.)

Section: Part-part-whole Ratios

Lesson 15: Part-Part-Whole Ratios

Goals

- Comprehend the word “parts” as an unspecified unit in sentences (written and spoken) describing ratios.
- Draw and label a tape diagram to solve problems involving ratios and the total amount. Explain (orally) the solution method.

Learning Targets

- I can create tape diagrams to help me reason about problems involving a ratio and a total amount.
- I can solve problems when I know a ratio and a total amount.

Lesson Narrative

Up to this point, students have worked with ratios of quantities where the units are the same (e.g., cups to cups) and ratios of quantities where the units are different (e.g., miles to hours). Sometimes in the first case, the sum of the quantities makes sense in the context, and we can ask questions about the total amount as well as the component parts. For example, when mixing 3 cups of yellow paint with 2 cups of blue paint, we get a total of 5 cups of green paint. (Notice that this does not always work; 3 cups of water mixed with 2 cups of dry oatmeal will not make 5 cups of soggy oatmeal.) In the paint scenario, the ratio of yellow paint to blue paint to green paint is $3 : 2 : 5$. Furthermore, if we double the amount of both yellow and blue paint, we will double the amount of green paint. In general, if the ratio of yellow to blue paint is equivalent, the ratio of yellow to blue to green paint will also be the equivalent. We can see this is always true because of the distributive property:

$a : b : (a + b)$ is equivalent to $2a : 2b : (2a + 2b)$ because $2a + 2b = 2(a + b)$.

These ratios are sometimes called “part-part-whole” ratios.

In this lesson, students learn about **tape diagrams** as a handy tool to represent ratios with the same units and as a way to reason about individual quantities (the parts) and the total quantity (the whole). Here students also see ratios expressed not in terms of specific units (milliliters, cups, square feet, etc.) but in terms of “parts” (e.g., the recipe calls for 2 parts of glue to 1 part of water).

Alignments

Building On

- 3.OA.B.5: Apply properties of operations as strategies to multiply and divide. Students need not use formal terms for these properties. Examples: If $6 \times 4 = 24$ is known, then $4 \times 6 = 24$ is also known. (Commutative property of multiplication.) $3 \times 5 \times 2$ can be found by $3 \times 5 = 15$,

then $15 \times 2 = 30$, or by $5 \times 2 = 10$, then $3 \times 10 = 30$. (Associative property of multiplication.)

Knowing that $8 \times 5 = 40$ and $8 \times 2 = 16$, one can find 8×7 as

$8 \times (5 + 2) = (8 \times 5) + (8 \times 2) = 40 + 16 = 56$. (Distributive property.)

- 5.NF.B.7: Apply and extend previous understandings of division to divide unit fractions by whole numbers and whole numbers by unit fractions. Students able to multiply fractions in general can develop strategies to divide fractions in general, by reasoning about the relationship between multiplication and division. But division of a fraction by a fraction is not a requirement at this grade.

Addressing

- 6.RP.A.3: Use ratio and rate reasoning to solve real-world and mathematical problems, e.g., by reasoning about tables of equivalent ratios, tape diagrams, double number line diagrams, or equations.

Instructional Routines

- Anticipate, Monitor, Select, Sequence, Connect
- Group Presentations
- MLR3: Clarify, Critique, Correct
- MLR8: Discussion Supports
- True or False

Required Materials

Graph paper

Snap cubes

Tools for creating a visual display

Any way for students to create work that can be easily displayed to the class. Examples: chart

paper and markers, whiteboard space and markers, shared online drawing tool, access to a document camera.

Required Preparation

Prepare a set of 50 red snap cubes and 30 blue snap cubes for each group of students.

Student Learning Goals

Let's look at situations where you can add the quantities in a ratio together.

15.1 True or False: Multiplying by a Unit Fraction

Warm Up: 10 minutes

This warm-up encourages students to use the meaning of fractions and properties of operations to reason about equations. While students may evaluate each side of the equation to determine if it is true or false, encourage students to think about the following ideas in each:

- The first question: Dividing is the same as multiplying by the reciprocal of the divisor.

- The second question: Adjusting the factors adjusts the products. If both factors increase, the resulting product will be greater than the original.
- The third question: The commutative property of multiplication.
- The fourth question: Decomposing a dividend into two numbers and dividing each by the divisor is a way to find the quotient of the original dividend.

Building On

- 3.OA.B.5
- 5.NF.B.7

Instructional Routines

- True or False

Launch

Display one problem at a time. Tell students to give a signal when they have an answer and a strategy. After each problem, give students 1 minute of quiet think time and follow with a whole-class discussion.

Student Task Statement

True or false?

$$\frac{1}{5} \cdot 45 = \frac{45}{5}$$

$$\frac{1}{5} \cdot 20 = \frac{1}{4} \cdot 24$$

$$42 \cdot \frac{1}{6} = \frac{1}{6} \cdot 42$$

$$486 \cdot \frac{1}{12} = \frac{480}{12} + \frac{6}{12}$$

Student Response

1. True. Division is the same as multiplying by the reciprocal.
2. False. Both factors increased.
3. True. Commutative Property of Multiplication.
4. True. Partial quotients.

Activity Synthesis

Ask students to share their strategies for each problem. Record and display their explanations for all to see. Ask students if or how the factors in the problem impacted the strategy choice. To involve more students in the conversation, consider asking:

- “Who can restate ___’s reasoning in a different way?”

- “Does anyone want to add on to ____’s strategy?”
- “Do you agree or disagree? Why?”

After each true equation, ask students if they could rely on the reasoning used on the given problem to think about or solve other problems that are similar in type. After each false equation, ask students how we could make the equation true.

15.2 Cubes of Paint

10 minutes

Up until now, students have worked with ratios of quantities given in terms of specific units such as milliliters, cups, teaspoons, etc. This task introduces students to the use of the more generic “parts” as a unit in ratios, and the use of **tape diagrams** to represent such ratios. In addition to thinking about the ratio between two quantities, students also begin to think about the ratio between the two quantities and their total.

Two important ideas to make explicit through the task and discussion:

- A ratio can associate quantities given in terms of a specific unit (as in 4 teaspoons of this to 3 teaspoons of that). A ratio can also associate quantities of the same kind without specifying particular units, in terms of “parts” (as in 4 parts of this to 3 parts of that). Any appropriate unit can be used in place of “parts” without changing the 4 to 3 ratio.
- A ratio can tell us about how two or more quantities relate to one another, but it can also tell us about the combined quantity (when that makes sense) and allow us to solve problems.

As students work, notice in particular how they approach the last two questions. Identify students who add snap cubes to represent the larger amount of paint, and those who use the original number of snap cubes but adjust their reasoning about what each cube represents. Be sure to leave enough time to debrief as a class and introduce tape diagrams afterwards.

Addressing

- 6.RP.A.3

Instructional Routines

- MLR8: Discussion Supports

Launch

Explain to students that they will explore paint mixtures and use snap cubes to represent them. Say: “To make a particular green paint, we need to mix 1 ml of blue paint to 3 ml of yellow.” Represent this recipe with 1 blue snap cube and 3 yellow ones and display each set horizontally (to mimic the appearance of a tape diagram).



Ask:

- “How much green paint will this recipe yield?” (4 ml of green paint.)
- “If each cube represents 2 ml instead of 1 ml, how much of blue and yellow do the snap cubes represent? How many ml of green paint will we have?” (2 ml of blue, 6 ml of yellow, and 8 ml of green.)
- “Is there another way to represent 2 ml of blue and 6 ml of yellow using snap cubes?” (We could use 2 blue snap cubes and 6 yellow ones.)
- “How do we refer to 2 ml of blue and 6 ml of yellow in terms of ‘batches?’” (2 batches.)

Highlight the fact that they could either represent 2 ml of blue and 6 ml of yellow with 2 blue snap cubes and 6 yellow ones (show this representation, if possible), or with 1 blue snap cube and 3 yellow ones (show representation), with the understanding that each cube stands for 2 ml of paint instead of 1 ml.

Explain to students that, in the past, they had thought about different amounts of ingredients in a recipe in terms of batches, but in this task they will look at another way to mix the right amounts specified by a ratio.

Arrange students in groups of 3–5. Provide 50 red snap cubes and 30 blue snap cubes to each group. Give groups time to complete the activity, and then debrief as a class.

Support for Students with Disabilities

Representation: Develop Language and Symbols. Use virtual or concrete manipulatives to connect symbols to concrete objects or values. Provide students with snap cubes, blocks or printed representations.

Supports accessibility for: Conceptual processing

Anticipated Misconceptions

Students may need help interpreting “Suppose each cube represents 2 ml.” If necessary, suggest they keep using one cube to represent 1 ml of paint. So, for example, the second question would be

represented by 5 *stacks of 2* red cubes and 3 *stacks of 2* blue cubes. If they use that strategy, each part of the tape diagram would represent one stack.

Student Task Statement

A recipe for maroon paint says, "Mix 5 ml of red paint with 3 ml of blue paint."

1. Use snap cubes to represent the amounts of red and blue paint in the recipe. Then, draw a sketch of your snap-cube representation of the maroon paint.
 - a. What amount does each cube represent?
 - b. How many milliliters of maroon paint will there be?
2.
 - a. Suppose each cube represents 2 ml. How much of each color paint is there?
Red: _____ ml Blue: _____ ml Maroon: _____ ml
 - b. Suppose each cube represents 5 ml. How much of each color paint is there?
Red: _____ ml Blue: _____ ml Maroon: _____ ml
3.
 - a. Suppose you need 80 ml of maroon paint. How much red and blue paint would you mix? Be prepared to explain your reasoning.
Red: _____ ml Blue: _____ ml Maroon: 80 ml
 - b. If the original recipe is for one batch of maroon paint, how many batches are in 80 ml of maroon paint?

Student Response

1. Show 5 red snap cubes and 3 blue ones.
 - a. Each snap cube represents 1 ml.

b. $1 + 1 + 1 + 1 + 1 = 5$, so there is 5 ml of red paint. $1 + 1 + 1 = 3$, so there is 3 ml of blue paint. $5 + 3 = 8$, so there is 8 ml of maroon paint.
2.
 - a. $2 + 2 + 2 + 2 + 2 = 10$, so there is 10 ml of red paint. $2 + 2 + 2 = 6$, so there is 6 ml of blue paint. $10 + 6 = 16$, so there is 16 ml of maroon paint.
 - b. There is 25 ml of red, since $5 \cdot 5 = 25$, and 15 ml of blue, since $5 \cdot 3 = 15$. $25 + 15 = 40$, so there is 40 ml of maroon paint.
3.
 - a. $80 \div 8 = 10$ and $10 \cdot 5 = 50$, so there is 50 ml red. $10 \cdot 3 = 30$, so there is 30 ml blue. $50 + 30 = 80$, so there is 80 ml maroon.

- b. There are 10 batches of paint, because each part changed from a value 1 ml to a value of 10 ml.

Activity Synthesis

Class discussion should center around how students used snap cubes to answer the questions and their approach to the last two questions. Invite some students to share their group's approach. Ask:

- "How did the snap cubes help you solve the first few problems?"
- "In one of the problems, you were only given the total amount of maroon paint. How did you find out the amounts of blue and yellow paint needed to produce 80 ml of maroon?"
- "How did you approach the last question?" (Add more cubes, or use the same representation of 5 red cubes and 3 blue ones.)

Discuss how the same 5 red cubes and 3 blue ones can be used to represent a total of 80 ml of blue paint. Explain that this situation can be represented with a **tape diagram**. A **tape diagram** is a horizontal strip that is partitioned into parts. Each part (like each snap cube) represents a value. It can be any value, as long as the same value is used throughout.

Show a tape diagram representing a 5 : 3 ratio of red paint to blue paint yielding 80 ml of maroon paint. Ask students where they see the 5, the 3, and the 80 being represented in the diagram. Discuss how many batches of paint are represented.



Show the tape diagram for green paint mixture discussed earlier. Students should be able to say that the ratio of blue to yellow paint is 1 : 3. Ask: "What value each part of the diagram would have to take to show a 20 ml mixture of green paint? How do you know?"



Guide students to see that, if each of the 4 total parts must be equal in value and amount to 20 ml, we could divide 20 by 5 to find out what each part represents. $20 \div 4 = 5$, so each part represents 5 ml of paint.

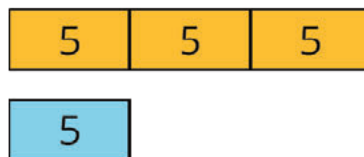

Support for English Language Learners

Representing: MLR8 Discussion Supports. To help students connect ratio language and ratio reasoning, invite a student to represent their reasoning using the snap cubes or with a tape diagram. Press for details by requesting that students challenge an idea, elaborate on an idea, or give an example. This will help students communicate with precise language.

Design Principle(s): Support sense-making

15.3 Sneakers, Chicken, and Fruit Juice

20 minutes

This activity allows students to practice reasoning about situations involving ratios of two quantities and their sum. It also introduces students to using “parts” in recipes (e.g., 3 parts oil with 2 parts soy sauce and 1 part orange juice), instead of more familiar units such as cups, teaspoons, milliliters, etc. Students may use tape diagrams to support their reasoning, or they may use other representations learned so far—discrete diagrams, number lines, tables, or equations. All approaches are welcome as long as students use them to represent the situations appropriately to support their reasoning.

As students work, monitor for different ways students reason about the problems, with or without using tape diagrams.

Addressing

- 6.RP.A.3

Instructional Routines

- Anticipate, Monitor, Select, Sequence, Connect

Launch

Keep students in the same groups. Provide graph paper and snap cubes (any three colors). Explain that they will now practice solving problems involving ratios and their combined quantities (similar to the green and purple paint in the previous task). Draw students to a ratio that uses “parts” as its unit. Ask students what they think “one part” means or amounts to, and how situations expressed in terms of “parts” could be diagrammed.

Before students begin working, make sure they understand that “parts” do not represent specific amounts, that the value of “one part” can vary but the size of all parts is equal, and that a tape diagram can be used to show these parts.

Anticipated Misconceptions

Students may think of each segment of a tape diagram as representing each cube, rather than as a flexible representation of an increment of a quantity. Help them set up the tapes with the correct number of sections and then discuss how many parts there are in all.

Student Task Statement

Solve each of the following problems and show your thinking. If you get stuck, consider drawing a **tape diagram** to represent the situation.

1. The ratio of students wearing sneakers to those wearing boots is 5 to 6. If there are 33 students in the class, and all of them are wearing either sneakers or boots, how many of them are wearing sneakers?
2. A recipe for chicken marinade says, "Mix 3 parts oil with 2 parts soy sauce and 1 part orange juice." If you need 42 cups of marinade in all, how much of each ingredient should you use?
3. Elena makes fruit punch by mixing 4 parts cranberry juice to 3 parts apple juice to 2 parts grape juice. If one batch of fruit punch includes 30 cups of apple juice, how large is this batch of fruit punch?

Student Response

1. 15 students are wearing sneakers. $33 \div 11 = 3$. The value of each unit is 3. $3 \cdot 5 = 15$.

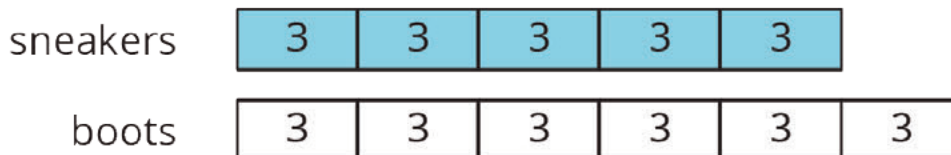

2. 14 cups of soy sauce. $42 \div 6 = 7$. The value of each unit is 7. $7 \cdot 3 = 21$. There are 21 cups of oil. $7 \cdot 2 = 14$.



3. 90 cups of punch. $30 \div 3 = 10$. The value of each unit is 10. $10 \cdot 3 = 30$. There are 30 cups of apple juice. $10 \cdot 4 = 40$. There are 40 cups cranberry juice. $10 \cdot 2 = 20$. There are 20 cups grape juice. $40 + 30 + 20 = 90$.



Are You Ready for More?

Using the recipe from earlier, how much fruit punch can you make if you have 50 cups of cranberry juice, 40 cups of apple juice, and 30 cups of grape juice?

Student Response

$112\frac{1}{2}$ cups. Figure out which ingredient you'd run out of first. Cranberry juice limits you to $12\frac{1}{2}$ batches, less than $13\frac{1}{3}$ for apple juice and 15 for grape juice. Then, multiply by 9 cups per batch.

Activity Synthesis

Select students to share their reasoning. Help students make connections between different representations, especially any tape diagrams.

15.4 Invent Your Own Ratio Problem

Optional: 10 minutes

In this activity, students have an opportunity to create their own equivalent ratio problem.

Addressing

- 6.RP.A.3

Instructional Routines

- Group Presentations
- MLR3: Clarify, Critique, Correct

Launch

Keep students in the same groups. Provide graph paper, snap cubes (any three colors), and tools for creating a visual display.

Support for Students with Disabilities

Engagement: Internalize Self Regulation. Check for understanding by inviting students to rephrase directions in their own words. Provide a project checklist that chunks the various steps of the activity into a set of manageable tasks.

Supports accessibility for: Organization; Attention

Student Task Statement

1. Invent another ratio problem that can be solved with a tape diagram and solve it. If you get stuck, consider looking back at the problems you solved in the earlier activity.
2. Create a visual display that includes:

- The new problem that you wrote, without the solution.
 - Enough work space for someone to show a solution.
3. Trade your display with another group, and solve each other's problem. Include a tape diagram as part of your solution. Be prepared to share the solution with the class.
 4. When the solution to the problem you invented is being shared by another group, check their answer for accuracy.

Student Response

Answers vary.

Activity Synthesis

Have each group share the peer-generated question it was assigned and the solution. Though the group that wrote the question will be responsible for confirming the answer, encourage all to listen to the reasoning each group used.

Support for English Language Learners

Reading, Writing: MLR3 Clarify, Critique, Correct. Use this routine to provide students with the opportunity to consider the important details and language that should be included in a ratio problem. Ask students to think about what the ratio problems they solved in the earlier activity all had in common, then display the following problem, "There are 5 lions and 2 birds. If there are 20 animals in the zoo, how many are lions or birds?" Give students 2 minutes of quiet think time to consider what is missing or unclear about the problem. Prompt discussion by asking, "What can we change to make this a better ratio problem?" Call students' attention to the language used to communicate the information necessary to solve a ratio problem, and to the importance of values that make sense for a given situation. If time allows, invite students to write and share a revised version of this problem.

Design Principle(s): Maximize meta-awareness; Optimize output (for explanation)

Lesson Synthesis

Today's ratio problems were different from the ones we've worked on so far because they include an additional piece of information:

- Can anyone identify what made these problems different? (They include the combined or total amount of the quantities in the ratio. This is possible because in each problem there was only one unit of measure and the total of the quantities made sense in the context.)
- How can a **tape diagram** represent these types of situations? (Each part of the tape represents a particular value, and the sum of those values represents the total amount.)

- How does changing the value of each part of the tape affect the total amount? (If the value is different, the combined sum will be different.) Review the use of a tape diagram for representing and solving a problem involving the total amount.

15.5 Room Sizes

Cool Down: 5 minutes

Addressing

- 6.RP.A.3

Launch

Provide access to graph paper.

Student Task Statement

The first floor of a house consists of a kitchen, playroom, and dining room. The areas of the kitchen, playroom, and dining room are in the ratio 4 : 3 : 2. The combined area of these three rooms is 189 square feet. What is the area of each room?

Student Response

kitchen	21	21	21	21
play room	21	21	21	
dining room	21	21		

All three rooms amount to 9 units. All three rooms make 189 square feet. $189 \div 9 = 21$, so each part of the tape diagram represents 21 square feet. The area of the kitchen is 84 square feet, the area of the playroom is 63 square feet, and the area of the dining room is 42 square feet.

Student Lesson Summary

A **tape diagram** is another way to represent a ratio. All the parts of the diagram that are the same size have the same value.

For example, this tape diagram represents the ratio of ducks to swans in a pond, which is 4 : 5.

ducks 

The first tape represents the number of ducks. It has 4 parts.

swans 

The second tape represents the number of swans. It has 5 parts.

There are 9 parts in all, because $4 + 5 = 9$.

Suppose we know there are 18 of these birds in the pond, and we want to know how many are ducks.

ducks 

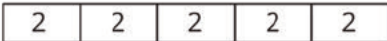
swans 

The 9 equal parts on the diagram need to represent 18 birds in all. This means that each part of the tape diagram represents 2 birds, because $18 \div 9 = 2$.

There are 4 parts of the tape representing ducks, and $4 \cdot 2 = 8$, so there are 8 ducks in the pond.

Glossary

- tape diagram

Lesson 15 Practice Problems

Problem 1

Statement

Here is a tape diagram representing the ratio of red paint to yellow paint in a mixture of orange paint.

a. What is the ratio of yellow paint to red paint? 

cups of red paint

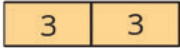
b. How many total cups of orange paint will this mixture yield? 

cups of yellow paint

Solution

a. $2 : 3$ (or equivalent)

b. 15 cups

Problem 2

Statement

At the kennel, the ratio of cats to dogs is 4 : 5. There are 27 animals in all. Here is a tape diagram representing this ratio.

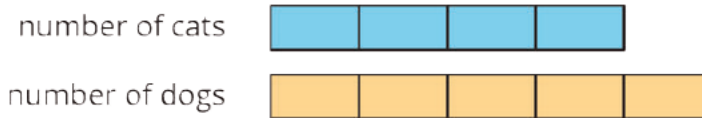

- What is the value of each small rectangle?
- How many dogs are at the kennel?
- How many cats are at the kennel?

Solution

- Each unit is 3, because $4 + 5 = 9$ and $27 \div 9 = 3$.
- There are 15 dogs, because $3 \cdot 5 = 15$.
- There are 12 cats, because $3 \cdot 4 = 12$.

Problem 3

Statement

Last month, there were 4 sunny days for every rainy day. If there were 30 days in the month, how many days were rainy? Explain your reasoning. If you get stuck, consider using a tape diagram.

Solution

There were 6 rainy days, because $4 + 1 = 5$, so there are 5 units total. $30 \div 5 = 6$, so each unit is worth 6.

Problem 4

Statement

Noah entered a 100-mile bike race. He knows he can ride 32 miles in 160 minutes. At this rate, how long will it take him to finish the race? Use each table to find the answer. Next, explain which table you think works better in finding the answer.

Table A:

distance (miles)	elapsed time (minutes)
32	160
1	
100	

Table B:

distance (miles)	elapsed time (minutes)
32	160
96	
4	
100	

Solution

He will finish the race in 500 minutes (or equivalent).

Table A:

distance (miles)	elapsed time (minutes)
32	160
1	5
100	500

Table B:

distance (miles)	elapsed time (minutes)
32	160
96	480
4	20
100	500

Answers vary. Sample response: The first table is more efficient, but they both work in getting the answer.

(From Unit 2, Lesson 12.)

Problem 5

Statement

A cashier worked an 8-hour day, and earned \$58.00. The double number line shows the amount she earned for working different numbers of hours. For each question, explain your reasoning.

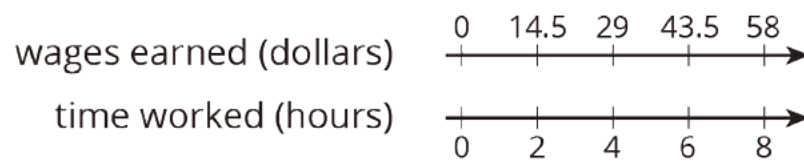

- a. How much does the cashier earn per hour?
- b. How much does the cashier earn if she works 3 hours?

Solution

- a. \$7.25 per hour. Possible reasoning: $14.5 \div 2 = 7.25$
- b. \$21.75. Possible reasoning: $(7.25) \cdot 3 = 21.75$

(From Unit 2, Lesson 13.)

Problem 6

Statement

A grocery store sells bags of oranges in two different sizes.

- The 3-pound bags of oranges cost \$4.
- The 8-pound bags of oranges for \$9.

Which oranges cost less per pound? Explain or show your reasoning.

Solution

The 8-pound bags cost less per pound. Possible strategies:

- Compare the cost for 24 pounds of oranges for both types of bags. 24 pounds cost \$32 when sold in 3-pound bags. 24 pounds cost \$27 when sold in 8-pound bags.
- Compare how much can be bought for the same amount of money. \$36 can buy 27 pounds of oranges in 3-pound bags, or it can buy 32 pounds in 8-pound bags.

(From Unit 2, Lesson 10.)

Lesson 16: Solving More Ratio Problems

Goals

- Choose and create diagrams to help solve problems involving ratios and the total amount.
- Compare and contrast (orally) different representations of and solution methods for the same problem.

Learning Targets

- I can choose and create diagrams to help think through my solution.
- I can solve all kinds of problems about equivalent ratios.
- I can use diagrams to help someone else understand why my solution makes sense.

Lesson Narrative

In this lesson, students use all representations they have learned in this unit—double number lines, tables, and tape diagrams—to solve ratio problems that involve the sum of the quantities in the ratio. They consider when each tool might be useful and preferable in a given situation and why (MP5). In so doing, they make sense of situations and representations, and are strategic in their choice of solution method (MP1).

Alignments

Addressing

- 6.RP.A.3: Use ratio and rate reasoning to solve real-world and mathematical problems, e.g., by reasoning about tables of equivalent ratios, tape diagrams, double number line diagrams, or equations.

Instructional Routines

- MLR4: Information Gap Cards
- MLR6: Three Reads
- MLR8: Discussion Supports
- Poll the Class
- Think Pair Share

Required Materials

Graph paper

Pre-printed slips, cut from copies of the blackline master

Rulers

Tools for creating a visual display

Any way for students to create work that can be easily displayed to the class. Examples: chart paper and markers, whiteboard space and markers, shared online drawing tool, access to a document camera.

Required Preparation

You will need the Solving More Ratio Problems Info Gap Blackline Master for this activity. Make one copy for every 6 students, and cut them up ahead of time. It is recommended to use a different color paper for each of the four pages, to make them easier to organize. A class set could be reused if you have more than one class.

Student Learning Goals

Let's compare all our strategies for solving ratio problems.

16.1 You Tell the Story

Warm Up: 10 minutes

This warm-up reminds students of previous work with tape diagrams and encourages a different way to reason with them. Students are given only a tape diagram and are asked to generate a concrete context to go with the representation.

Students' stories should have the following components:

- the same unit for both quantities in the ratio
- a ratio of 7 : 3
- scaling by 3, or 3 units per part
- They may also have a quantity of 30 that represents the sum of the two quantities in the ratio.

As students work, identify a few different students whose stories are clearly described and are consistent with the diagram so that they can share later.

Addressing

- 6.RP.A.3

Instructional Routines

- Think Pair Share

Launch

Ask students to share a few things they remember about tape diagrams from the previous lesson. Students may recall that:

- We draw one tape for every quantity in the ratio. Each tape has parts that are the same size.
- We draw as many parts as the numbers in the ratio show (e.g., a 2 : 3 ratio: we draw 2 parts in a tape and 3 parts in another tape).
- Each part represents the same value.
- Tape diagrams can be used to think about a ratio of parts and the total amount.

Tell students their job is to come up with a valid situation to match a given tape diagram. Give students some quiet thinking time, and then time to share their response with a partner.

Anticipated Misconceptions

Students may misunderstand the meaning of the phrase “with two quantities” and simply come up with a situation involving ten identical groups of three. Point out that the phrase means that the row of seven groups of three should represent something different than the row of three groups of three.

Students may also come up with a situation involving different units, for example, quantity purchased and cost, or distance traveled and time elapsed. Remind them that the parts of tape are meant to represent the same value, so we need a situation that uses the same units for both parts of the ratio.

Student Task Statement

Describe a situation with two quantities that this tape diagram could represent.

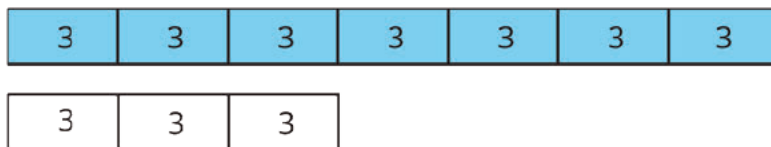

Student Response

Answers vary. Examples might be

- One batch of purple paint is made by mixing 7 cups of blue with 3 cups of red. In three batches, there are 30 cups of purple paint, which is made of 21 cups of blue paint and 9 cups of red paint.
- There are 30 fish in an aquarium. The ratio of blue fish to red fish is 7 : 3. There are 21 blue fish and 9 red fish.

Activity Synthesis

Invite a few students to share their stories with the class. As they share, consider recording key details about each story for all students to see. Then, ask students to notice similarities in the different scenarios.

Guide students to see that they all involve the same units for both quantities of the ratio, a ratio of 7 to 3, and either 3 units per part or scaling by 3. They may also involve an amount of 30 units, representing the sum of the two quantities.

16.2 A Trip to the Aquarium

20 minutes

This task prompts students to solve a single problem using a triple number line, a table, or a tape diagram. Either assign each student a representation or allow students to choose the representation they prefer. During the following discussion, they will compare and contrast the three representations and identify the relative merits of the different representations for the different problems.

Students will have varying opinions about which representation they prefer and why. Their views may stem from observations such as:

- Number lines and tables involve scaling up individual quantities to find the total. Tape diagrams involve starting with the total and breaking it down into equal groups.
- It is hard to take shortcuts with number line diagrams.
- We can use the number line diagram or the table efficiently by thinking, “17 times what is 85?” This value tells us how many “batches” of tickets the teacher had to order.
- When using a tape diagram, it was easier to count 17 groups and compute $85 \div 17$ to find how many tickets each group needs.

Students may struggle to represent the problem with a tape diagram. As they work, notice any trends that may need to be addressed with the class.

Addressing

- 6.RP.A.3

Instructional Routines

- MLR6: Three Reads
- Poll the Class

Launch

Tell students that they will now solve a ratio problem in one of three different ways. Either assign each student one of the representations or instruct them to choose one representation to use.

Give students quiet think time to complete the activity and then, optionally, time to share their responses with a small group or in pairs.

Support for Students with Disabilities

Representation: Develop Language and Symbols. Maintain a display of important terms and vocabulary. During the launch, take time to review the following terms from previous lessons that students will need to access for this activity: tape diagrams, quantities, ratios, batch.

Supports accessibility for: Memory; Language

Support for English Language Learners

Reading: MLR6 Three Reads. This is one of the first times Math Language Routine 6 is suggested as a support in this course. In this routine, students are supported in reading a mathematical text, situation, or word problem three times, each with a particular focus. During the first read, students focus on comprehending the situation; during the second read, students identify quantities; during the third read, students brainstorm possible strategies to answer the question. The question to be answered does not become a focus until the third read so that students can make sense of the whole context before rushing to a solution. The purpose of this routine is to support students' reading comprehension as they make sense of mathematical situations and information through conversation with a partner.

Design Principle(s): Support sense-making

How It Happens:

1. In the first read, students read the problem with the goal of comprehending the situation. Do not reveal the questions with the three options for solving at this point.

Invite a student to read the description of the situation aloud while everyone else reads with them and then ask, "What is this situation about?"

Allow one minute to discuss with a partner, and then share with the whole class. A clear response would be: "buying tickets for a class trip to an aquarium."

2. In the second read, students analyze the mathematical structure of the story by naming quantities.

Invite students to read the problem aloud with their partner or select a different student to read to the class and then prompt students by asking, "What can be counted or measured in this situation? For now we don't need to focus on how many or how much of anything, but what can we count in this situation?" Give students one minute of quiet think time followed by another minute to share with their partner. Quantities may include: total number of tickets bought; number of students; number of chaperones; ratio of chaperones to students.

3. In the third read, students brainstorm possible mathematical strategies to answer the question, "How many tickets are for chaperones, and how many are for students?" (Still do not reveal the three given options for solving.)

Invite students to read the problem aloud with their partner or select a different student to read to the class. Instruct students to think of ways to approach the question without actually solving the problem.

Consider using these questions to prompt students: “What strategy or method would you try first?,” “How could a diagram help you approach this question?,” and “Can you think of a different way to solve it?”

Give students one minute of quiet think time followed by another minute to discuss with their partner. Provide this sentence frame as partners discuss: “One way to approach the question would be to....”

Sample responses include: “I would figure out possibilities for the number of students and number of chaperones and see which one adds up to 85.”, “I know that if I divide 85 by 2, it won’t work because there are more students than chaperones, so the groups are not equal, so I know I have to split it up differently.”, “I would draw a tape diagram to figure out different lengths that fit the ratio of students to chaperones.”, and “I would use a double number line/table to scale up the ratio of students to chaperones.” This will help students concentrate on making sense of the situation before rushing to a solution or method.

4. As partners are discussing their strategies, select 1–2 students to share their ideas with the whole class.

Listen for quantities that were mentioned during the second read, and take note of strategies that make explicit the relationships between number of tickets and number of students, number of tickets and number of chaperones, or number of students and number of chaperones. As students are presenting their strategies to the whole class, create a display that summarizes ideas about the question.

5. Post the display where all students can use it as a reference, and finally reveal the actual problems and ensure that a variety of strategies are chosen by students.

Anticipated Misconceptions

The number line and table representations are organized similarly. For example, one could make progress with both of them simply by skip counting and keeping an eye out for a total of 85 people. The tape diagram, though, is organized in a much different way. Equivalent ratios are not listed out, but rather equivalent ratios arise from thinking about how the diagram could represent any number of batches. Students may thus mistakenly treat the tape diagram like a double number line diagram—they may start writing 15, 30, 45, etc. in the “kids” tape, for example. Once this plays out, students *may* self-regulate once they notice there are only 2 boxes in the chaperones’ row. But they may decide to just draw more boxes! Reorient these students by asking how many parts of tape there are (17), and reminding them each part of tape represents equal numbers of people, and that there are 85 total people. The presentation of correct work during the discussion could be used as an opportunity to remediate, as well. For example, consider asking a student to explain what they understand about another student’s correct work.

Student Task Statement

Consider the problem: A teacher is planning a class trip to the aquarium. The aquarium requires 2 chaperones for every 15 students. The teacher plans accordingly and orders a total of 85 tickets. How many tickets are for chaperones, and how many are for students?

1. Solve this problem in *one* of three ways:

Use a triple number line.

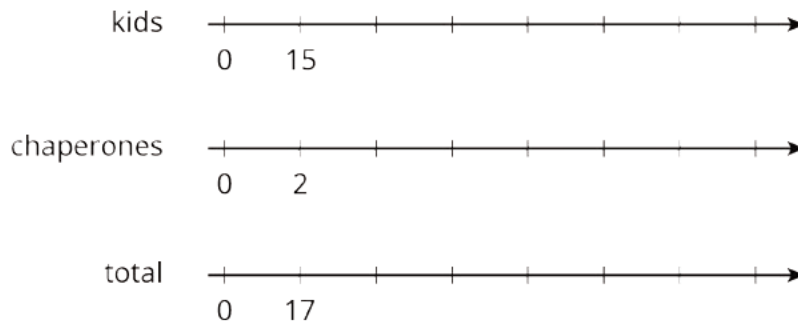

Use a table.
(Fill rows as needed.)

kids	chaperones	total
15	2	17

Use a tape diagram.



2. After your class discusses all three strategies, which do you prefer for this problem and why?

Student Response

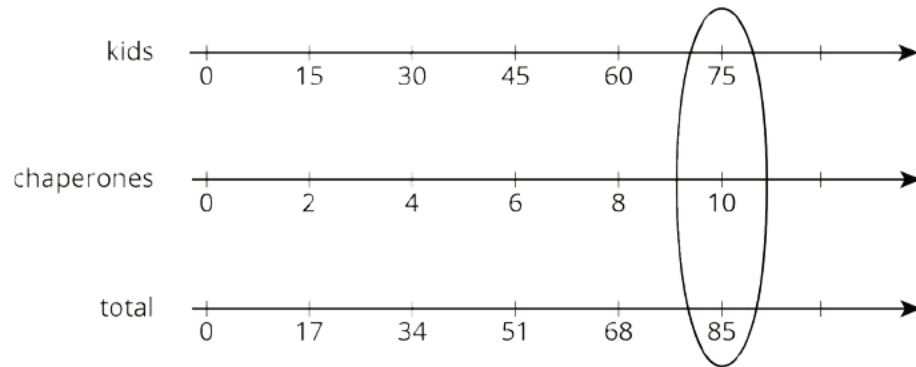

a.

kids	chaperones	total
15	2	17
30	4	34
45	6	51
60	8	68
75	10	85

} not enough

b.

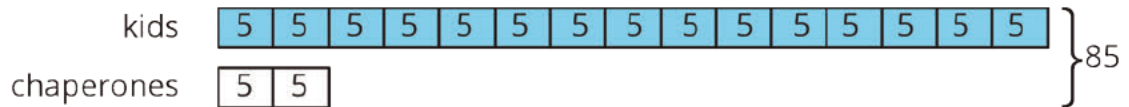

1. c. There are a total of 17 boxes. $85 \div 17 = 5$. Each part of tape is worth 5 tickets, so we can see that the teacher ordered 75 tickets for kids and 10 tickets for chaperones.

2. Answers vary.

Are You Ready for More?

Use the digits 1 through 9 to create three equivalent ratios. Use each digit only one time.

: is equivalent to : and :

Student Response

One solution is $6 : 3$, $18 : 9$, and $54 : 27$.

Note: this problem was inspired by the problem *Finding Equivalent Ratios* by Graham Fletcher published at openmiddle.com and used here with permission.

Activity Synthesis

Before debriefing as a class, consider arranging students in groups of 3, where a group includes one student who used each representation. Give them time to see if they got the same answer and compare and contrast the representations.

Solicit students' reactions to the three strategies, encouraging them to identify what is similar and different about the approaches. Consider polling the class for their preferred strategy. Ask 1–2 students favoring each method to explain why. This can also be a discussion about what worked well in this or that approach, and what might make this or that approach more complete or easy to understand. While there is no right or wrong answer with regards to their preferred strategy, look out for unsupported reasoning or misunderstandings.

Some students may prefer the tape diagram because the solution path seems more direct, but caution them against trying to use a tape diagram any time they see a ratio problem. Because tape diagrams involve equal-sized parts, they can only be used to represent quantities with the same unit. If different units are involved, the parts of one tape and those of the other will not represent an identical quantity.

16.3 Salad Dressing and Moving Boxes

10 minutes

This activity gives students a chance to apply the different strategies they have learned to solve ratio problems and to decide on methods that would make the most sense in given situations. *If desired*, you can have students complete this activity as an info gap, by instructing them to close their books or devices and distributing slips cut from the blackline master. Alternatively, students can simply complete the two problems that are printed in the task statement.

Each problem may lend itself better to a particular representation than to others. Below are sample arguments in support of a representation for each problem, though options may vary:

- The salad dressing problem can be well represented by all three representations because it involves small numbers and simple multiplication.
- The box-moving problem would be inefficient to represent with a number line diagram, since it would require making 8 half-hour jumps to find the total of 72. Either a tape diagram or a table showing more straightforward multiplication would be more efficient.

The time needed to solve the problems may depend on the representation students choose to use.

Addressing

- 6.RP.A.3

Instructional Routines

- MLR4: Information Gap Cards
- MLR8: Discussion Supports

Launch

Tell students they will continue to practice using the tools at their disposal—number lines, tables, and tape diagrams—to solve ratio problems.

Provide access to graph paper and rulers. Arrange students in groups of 2.

If using the info gap routine: Explain the info gap structure and consider demonstrating the protocol. In each group, distribute a problem card to one student and a data card to the other student. Give students who finish early a different pair of cards and ask them to switch roles.

If not using the info gap routine: Ask students to complete both questions and then compare their strategies with their partner. Partners should work together to resolve any discrepancies.

Support for Students with Disabilities

Action and Expression: Internalize Executive Functions. Begin with a small-group or whole-class demonstration and think aloud of a sample situation to remind students how to use the info gap structure. Keep the worked-out table and double number lines on display for students to reference as they work.

Supports accessibility for: Memory; Conceptual processing

Support for English Language Learners

Conversing: MLR4 Information Gap. Use this routine to give students a purpose for discussing information necessary to solve ratio problems. Display questions or question starters for students who need a starting point such as: “Can you tell me . . . (specific piece of information)”, and “Why do you need to know . . . (that piece of information)?”

Design Principle(s): Cultivate Conversation

Anticipated Misconceptions

While thinking through problems, it is common for students to hold the meanings of their representations (numbers, quantities, markings, etc.) in their heads without writing them down. When students are getting their solutions ready for others to look at, though, remind them of the importance of labeling quantities and units of measure and making the steps in their thinking clear.

Some students may choose the same strategy or representation each time. If their answers are accurate, this is fine. However, if time allows, ask them to check if they can verify their answer using an alternative strategy.

If using the info gap routine: Students holding a Problem Card may have trouble thinking of appropriate questions to ask their partner. Encourage them to revisit the problem at hand and think about the kinds of information that might be helpful or relevant. (For example, if the problem

is about how long it would take to perform something, ask students how they usually gauge the amount of time needed for something. Ask, “What would the amount of time depend on?”)

Student Task Statement

Solve each problem, and show your thinking. Organize it so it can be followed by others. If you get stuck, consider drawing a double number line, table, or tape diagram.

1. A recipe for salad dressing calls for 4 parts oil for every 3 parts vinegar. How much oil should you use to make a total of 28 teaspoons of dressing?
2. Andre and Han are moving boxes. Andre can move 4 boxes every half hour. Han can move 5 boxes every half hour. How long will it take Andre and Han to move all 72 boxes?

Student Response

Each problem can be approached with all three representations. The strategies shown reflect a straightforward or efficient approach for each problem (although this is a matter of opinion).

1. 16 teaspoons. $28 \div 7 = 4$ and $4 \cdot 4 = 16$.

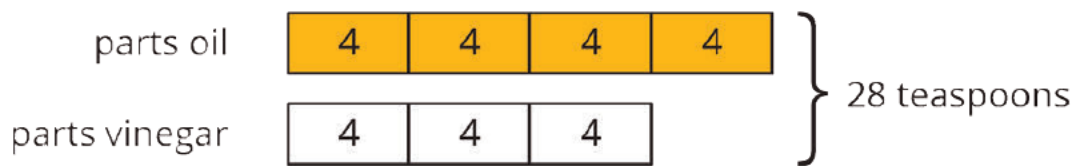

2. 4 hours. The total number of boxes carried each half hour is 9. $72 = 9 \cdot 8$. Therefore, it takes $8 \frac{1}{2}$ -hour increments, or 4 hours, to move 72 boxes.

boxes moved by Andre	boxes moved by Noah	total boxes moved	elapsed time (hours)
4	5	9	$\frac{1}{2}$
32	40	72	4

Activity Synthesis

After students have had time to work, share the correct answers and ask students for their preferences about representations. Some guiding questions:

- “Is there a particular representation you tend to try first?”
- “Does one seem more efficient than the others?”
- “Did the situation in a problem affect your choice? If so, what features of a problem might steer you toward or away from a particular strategy?”

Support for English Language Learners

Speaking: MLR8 Discussion Supports. Revoice student ideas to demonstrate mathematical language. Press for details in students' explanations by requesting that students challenge an idea, elaborate on an idea, or give an example. This will help students communicate with more precise language.

Design Principle(s): Cultivate conversation

Lesson Synthesis

This lesson was all about understanding that there are different, valid representations to use for problems involving equivalent ratios. For some problems, one representation is easier to use than others. There are no hard and fast rules. As long as the diagram correctly shows the mathematics, and the problem solver can explain it, it's okay. Some guidelines to draw out are:

- Tape diagrams are most likely to be helpful when the parts of the ratio have the same kind of units and the sum of the quantities is meaningful in the context. For example, cups to cups; miles to miles; boxes moved to boxes moved.
- Number lines are a good choice when it helps to visualize how far apart numbers are from each other. They are harder to use with very big or very small numbers.
- Tables work well in almost all situations. Ask students to articulate good habits when solving equivalent ratio problems with the different representations. Some ideas might include:
 - Label each part of the diagram with what it represents.
 - Use brackets to indicate total amounts.
 - Make sure you read what the question is asking and answer it.
 - Make sure you make the answer easy to find.
 - Include units in your answer. For example, instead of just writing "4," write "4 cups."

16.4 Pizza-making Party

Cool Down: 5 minutes

Addressing

- 6.RP.A.3

Student Task Statement

You are having a pizza-making party for a number of people. You will need 6 ounces of dough and 4 ounces of sauce for each person at this party. If you used a total of 130 ounces of dough and sauce all together,

1. How many ounces of dough were used at the party?
2. How many ounces of sauce were used at the party?
3. How many people were at the party?

Student Response

1. 78 ounces of dough.
2. 52 ounces of sauce.

Possible strategy:

dough (ounces)	sauce (ounces)	total (ounces)
6	4	10
78	52	130

3. 12 guests. You bought ingredients for 13 people. $6 \cdot 13 = 78$ and $4 \cdot 13 = 52$. Since you bought some for yourself, there are 12 guests coming.

Student Lesson Summary

When solving a problem involving equivalent ratios, it is often helpful to use a diagram. Any diagram is fine as long as it correctly shows the mathematics and you can explain it.

Let's compare three different ways to solve the same problem: The ratio of adults to kids in a school is 2 : 7. If there is a total of 180 people, how many of them are adults?

- *Tape diagrams* are especially useful for this type of problem because both parts of the ratio have the same units ("number of people") and we can see the total number of parts.



This tape diagram has 9 equal parts, and they need to represent 180 people total. That means each part represents $180 \div 9$, or 20 people.

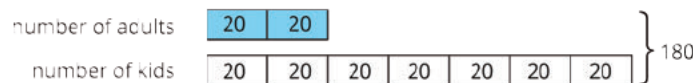

Two parts of the tape diagram represent adults. There are 40 adults in the school because $2 \cdot 20 = 40$.

- *Double or triple number lines* are useful when we want to see how far apart the numbers are from one another. They are harder to use with very big or very small numbers, but they could support our reasoning.

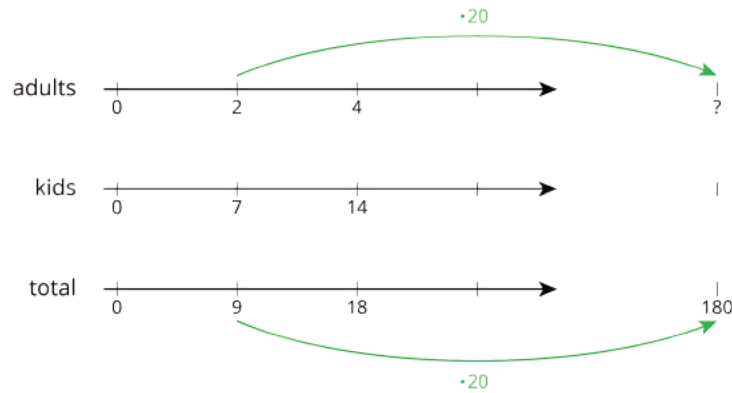

- *Tables* are especially useful when the problem has very large or very small numbers.

adults	kids	total
2	7	9
?		180

We ask ourselves, “9 times what is 180?” The answer is 20. Next, we multiply 2 by 20 to get the total number of adults in the school.

Another reason to make diagrams is to communicate our thinking to others. Here are some good habits when making diagrams:

- Label each part of the diagram with what it represents.
- Label important amounts.
- Make sure you read what the question is asking and answer it.
- Make sure you make the answer easy to find.
- Include units in your answer. For example, write “4 cups” instead of just “4.”
- Double check that your ratio language is correct and matches your diagram.

Lesson 16 Practice Problems

Problem 1

Statement

Describe a situation that could be represented with this tape diagram.

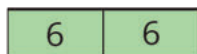

Solution

Answers vary. Sample response: There are 30 people at a movie. The ratio of teenagers to adults is 3 to 2. There are 18 teenagers and 12 adults.

Problem 2

Statement

There are some nickels, dimes, and quarters in a large piggy bank. For every 2 nickels there are 3 dimes. For every 2 dimes there are 5 quarters. There are 500 coins total.

- How many nickels, dimes, and quarters are in the piggy bank? Explain your reasoning.
- How much are the coins in the piggy bank worth?

Solution

- 80 nickels, 120 dimes, 300 quarters. Possible strategies:
 - For every 2 nickels there are 3 dimes, so for every 4 nickels there are 6 dimes. For every 2 dimes there are 5 quarters, so for every 6 dimes there are 15 quarters. The ratio of nickels to dimes to quarters is 4 to 6 to 15, a total of 25 coins in the group. There are 500 coins, which means 20 groups of coins, since $500 \div 25 = 20$. There are 80 nickels ($20 \cdot 4 = 80$), 120 dimes ($20 \cdot 6 = 120$), and 300 quarters ($20 \cdot 15 = 300$).
 - Using a table:

nickles	dimes	quarters	total
4	6	15	25
16	24	60	100
80	120	300	500

- \$91. The nickels are worth \$4, the dimes are worth \$12, and the quarters are worth \$75, making a total of \$91.

Problem 3

Statement

Two horses start a race at the same time. Horse A gallops at a steady rate of 32 feet per second and Horse B gallops at a steady rate of 28 feet per second. After 5 seconds, how much farther will Horse A have traveled? Explain or show your reasoning.

Solution

Horse A will have traveled 20 feet farther. Possible reasoning:

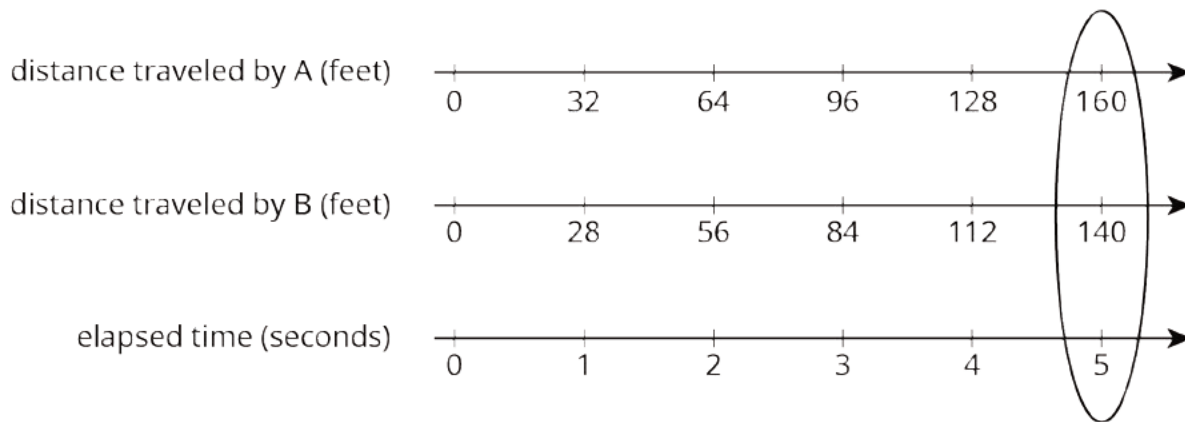

$$160 - 140 = 20$$

Problem 4

Statement

Andre paid \$13 for 3 books. Diego bought 12 books priced at the same rate. How much did Diego pay for the 12 books? Explain your reasoning.

Solution

\$52. Sample explanation: 12 is 4 groups of 3 so Diego's books will cost 4 times as much as Andre's and $4 \cdot 13 = 52$.

(From Unit 2, Lesson 10.)

Problem 5

Statement

Which polyhedron can be assembled from this net?

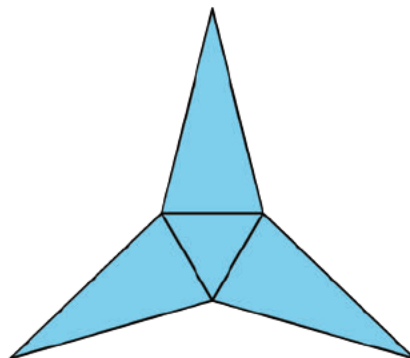

- A. A triangular pyramid
- B. A trapezoidal prism
- C. A rectangular pyramid
- D. A triangular prism

Solution

A

(From Unit 1, Lesson 15.)

Problem 6

Statement

Find the area of the triangle. Show your reasoning. If you get stuck, consider drawing a rectangle around the triangle.

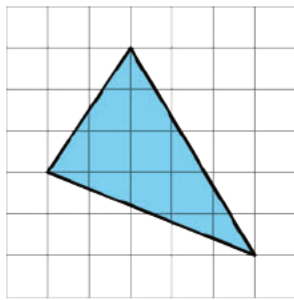

Solution

9.5 square units. Explanations vary. Sample response:

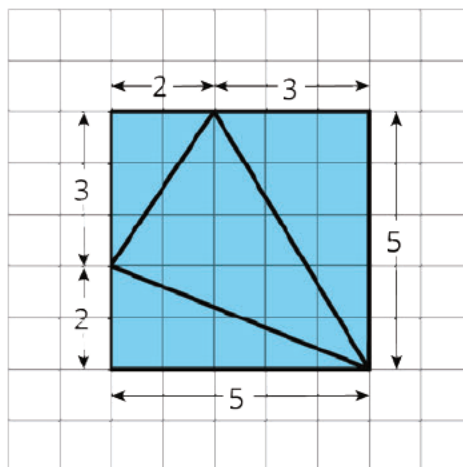

Surround the triangle with a 5 by 5 unit square, which has an area of 25 square units. From the area of the square, subtract the areas of the three right triangles. The total area of the right triangles is

15.5 square units, because $3 + 5 + 7.5 = 15.5$. The area of the given triangle is 9.5 square units, since $25 - 15.5 = 9.5$.

(From Unit 1, Lesson 10.)

Section: Let's Put it to Work

Lesson 17: A Fermi Problem

Goals

- Apply reasoning developed throughout this unit to an unfamiliar problem.
- Decide what information is needed to solve a real-world problem.
- Make simplifying assumptions about a real-world situation.

Learning Targets

- I can apply what I have learned about ratios and rates to solve a more complicated problem.
- I can decide what information I need to know to be able to solve a real-world problem about ratios and rates.

Lesson Narrative

This unit concludes with an opportunity for students to apply the reasoning developed so far to solve an unfamiliar, Fermi-type problem. Students must take a problem that is not well-posed and make assumptions and approximations to simplify the problem (MP4) so that it can be solved, which requires sense making and perseverance (MP1). To understand what the problem entails, students break down larger questions into more-manageable sub-questions. They need to make assumptions, plan an approach, and reason with the mathematics they know.

Engineers, computer scientists, physicists, and economists often make simplifying assumptions as they tackle complex problems involving mathematical modeling. Later in the year, unit 9 provides more exploration with solving Fermi problems, which are examples of mathematical modeling (MP4).

Alignments

Building On

- 4.MD: Grade 4 - Measurement and Data
- 4.MD.A: Solve problems involving measurement and conversion of measurements from a larger unit to a smaller unit.
- 5.MD: Grade 5 - Measurement and Data

Addressing

- 6.RP.A: Understand ratio concepts and use ratio reasoning to solve problems.
- 6.RP.A.3: Use ratio and rate reasoning to solve real-world and mathematical problems, e.g., by reasoning about tables of equivalent ratios, tape diagrams, double number line diagrams, or equations.

Instructional Routines

- Group Presentations
- MLR7: Compare and Connect
- MLR8: Discussion Supports

Required Materials

Tools for creating a visual display

Any way for students to create work that can be easily displayed to the class. Examples: chart

paper and markers, whiteboard space and markers, shared online drawing tool, access to a document camera.

Student Learning Goals

Let's solve a Fermi problem.

17.1 Fix It!

Warm Up: 10 minutes

This activity encourages students to apply ratio reasoning to solve a problem they might encounter naturally outside a mathematics classroom. The warm up invites open-ended thinking that is validated by mathematical reasoning, which is the type of complex thinking needed to solve Fermi problems in the following activities.

Addressing

- 6.RP.A.3

Launch

Arrange students in groups of 2. Display the image for all to see.

Optionally, instead of the abstract image, you could bring in a clear glass, milk, and cocoa powder. Pour 1 cup of milk into the glass, add 5 tablespoons of cocoa powder, and introduce the task that way.

Tell students to give a signal when they have an answer and a strategy. Give students 2 minutes of quiet think time.

Student Task Statement

Andre likes a hot cocoa recipe with 1 cup of milk and 3 tablespoons of cocoa. He poured 1 cup of milk but accidentally added 5 tablespoons of cocoa.

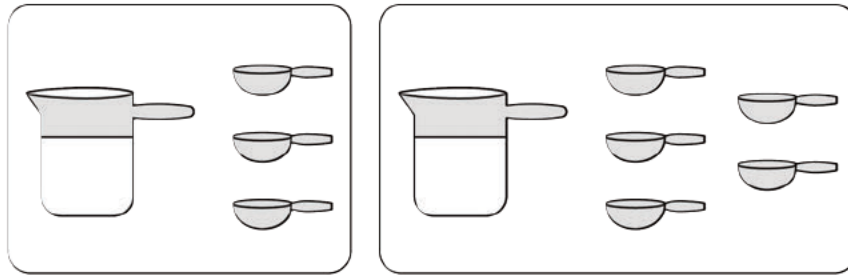

1. How can you fix Andre's mistake and make his hot cocoa taste like the recipe?
2. Explain how you know your adjustment will make Andre's hot cocoa taste the same as the one in the recipe.

Student Response

1. Answers vary. Possible strategies: Add 1 more tablespoon of cocoa and 1 cup of milk or add $\frac{2}{3}$ cup of milk.
2. The ratios for the recipe and for the fixed mixture are equivalent.

Activity Synthesis

Invite students to share their strategies with the class and record them for all to see. After each explanation, ask the class if they agree or disagree and how they know two hot cocoas will taste the same.

17.2 Who Was Fermi?

15 minutes

In this activity, students are introduced to the type of thinking useful for Fermi problems. The purpose of this activity is not to come up with an answer, but rather to see different ways to break a Fermi problem down into smaller questions that can be measured, estimated, or calculated.

Much of the appeal of Fermi problems is in making estimates for things that in modern times we *could* easily look up. To make this lesson more fun and interesting, challenge students to work without performing any internet searches.

As students work, notice the range of their estimates and the sub-questions they formulate to help them answer the large questions. Some examples of productive sub-questions might be:

- What information do we *know*?
- What information can be *measured*?
- What information cannot be measured but can be *calculated*?
- What *assumptions* should we make?

Building On

- 4.MD.A
- 5.MD

Instructional Routines

- MLR8: Discussion Supports

Launch

Open the activity with one or two questions that your students may find thought-provoking. Some ideas:

- “How many times does your heart beat in a year?”
- “How many hours of television do you watch in a year?”
- “Some research has shown that it takes 10,000 hours of practice for a person to achieve the highest level of performance in any field—sports, music, art, chess, programming, etc. If you aspire to be a top performer in a field you love—as Michael Jordan in basketball, Tiger Woods in golf, Maya Angelou in literature, etc., how many years would it take you to meet that 10,000-hour benchmark if you start now? How old would you be?”

Give students a moment to ponder a question and make a rough estimate. Then, share that the questions above are called “Fermi problems,” named after Enrico Fermi, an Italian physicist who loved to think up and discuss problems that are impossible to measure directly, but can be roughly estimated using known facts and calculations. Here are some other examples of Fermi problems:

- “How long would it take to paddle across the Pacific Ocean?”
- “How much would it cost to replace all the windows on all the buildings in the United States?”

Share the questions above or select a few other Fermi-type questions that are likely to intrigue your students. Have some resources on hand to support the investigation on your chosen questions (e.g., have a globe handy if the question about paddling across the Pacific is on your short list). As a class, decide on one question to pursue. For this activity, consider giving students the option to either work independently or in groups of two.

Support for Students with Disabilities

Representation: Provide Access for Perception. Display or provide students with a physical copy of the written directions and read them aloud. Check for understanding by inviting students to rephrase directions in their own words.

Supports accessibility for: Language; Memory

Support for English Language Learners

Conversing, Representing: MLR8 Discussion Supports. Use this routine to support student understanding of Fermi problems. After discussing some of the different Fermi problems presented in the launch, present nonexamples such as "How many students are in our classroom right now?" and "How tall is a stack of 20 pennies?" Ask pairs of students to select and critique one of the questions, and then collaborate to write a new version that represents a Fermi-type question. Invite students to share their new Fermi questions, and ask the class to identify the changes that made them Fermi questions.

Design Principle(s): Cultivate conversation; Support sense-making

Student Task Statement

1. Record the Fermi question that your class will explore together.
2. Make an estimate of the answer. If making an estimate is too hard, consider writing down a number that would definitely be too low and another number that would definitely be too high.
3. What are some smaller sub-questions we would need to figure out to reasonably answer our bigger question?
4. Think about how the smaller questions above should be organized to answer the big question. Label each smaller question with a number to show the order in which they should be answered. If you notice a gap in the set of sub-questions (i.e., there is an unlisted question that would need to be answered before the next one could be tackled), write another question to fill the gap.

Student Response

Answers vary depending on the question explored. For "How long would it take to paddle across the Pacific Ocean?" some sub-questions might be:

- What is the distance across the Pacific Ocean?
- At what speed can you paddle a boat?
- Do we assume that someone paddles continuously, or that they take breaks to sleep?

Activity Synthesis

First, ask students to share their estimates. Note the lowest and highest estimates, and point out that it is perfectly acceptable for an estimate to be expressed as a range of values rather than a single value.

Ask students to share some of their smaller questions. Then, discuss how you might come up with answers to these smaller questions, which likely revolve around what information is known, can be

measured, or can be computed. Also, discuss how our assumptions about the situation affect how we solve the problem.

17.3 Researching Your Own Fermi Problem

30 minutes

This activity asks students to choose or pose a Fermi problem and solve it, with the aim of promoting the reasoning and tools developed in this unit. Students brainstorm potential problems, choose one, and—after your review—use a graphic organizer to help them formulate the sub-questions that could support their problem solving. They go on to solve their chosen Fermi problem.

To encourage ratio reasoning and the use of tools such as double number lines and tables, look for problems that involve *two* quantities. Questions that involve one quantity can be solved with multi-step multiplication and without ratio reasoning (e.g., “How many pens are there at the school?” involves only one quantity—the number of pens). But a problem such as “How much would it cost to replace all the windows on all buildings in the U.S.?” or “How long would it take to paddle across the Pacific Ocean?” involves accounting for two quantities at the same time (cost and number of windows, or time and distance across the Pacific) and is more likely to elicit ratio reasoning. Keep this in mind as you help students sift through their ideas.

Building On

- 4.MD
- 5.MD

Addressing

- 6.RP.A

Instructional Routines

- Group Presentations
- MLR7: Compare and Connect

Launch

Explain to students that they will now brainstorm some Fermi problems they are interested in answering and select one to solve. Consider sharing a few more examples of Fermi problems to jumpstart their thinking:

- How much would it cost to charge all the students’ cell phones in the school for a month?
- How much does it cost to operate a car for a year?
- How long would it take to make a sandwich for everyone living in our town?
- How long would it take to read the dictionary out loud?

- How long would it take to give every dog in America a bath?

Tell students that once they have a few good ideas, they should pause and get your attention so that you could help to decide on the one problem to pursue.

Arrange students in groups of 2, if desired. Provide tools for creating a visual display.

Support for Students with Disabilities

Engagement: Develop Effort and Persistence. Encourage and support opportunities for peer interactions. Invite students to talk about their ideas with a partner before writing them down. Display sentence frames to support students when they explain their strategy. For example, “How much would it cost to . . .?” or “How long would it take to . . .?”

Supports accessibility for: Language; Social-emotional skills

Anticipated Misconceptions

Students may think of problems that do not lend themselves to ratio reasoning because they only involve one quantity. If they have trouble coming up with any good options, offer them some examples. It may also be helpful to have a list of sample problems that students could refer to in creating their own problem.

Student Task Statement

1. Brainstorm at least five Fermi problems that you want to research and solve. If you get stuck, consider starting with “How much would it cost to . . .?” or “How long would it take to . . .?”
2. Pause here so your teacher can review your questions and approve one of them.
3. Use the graphic organizer to break your problem down into sub-questions.

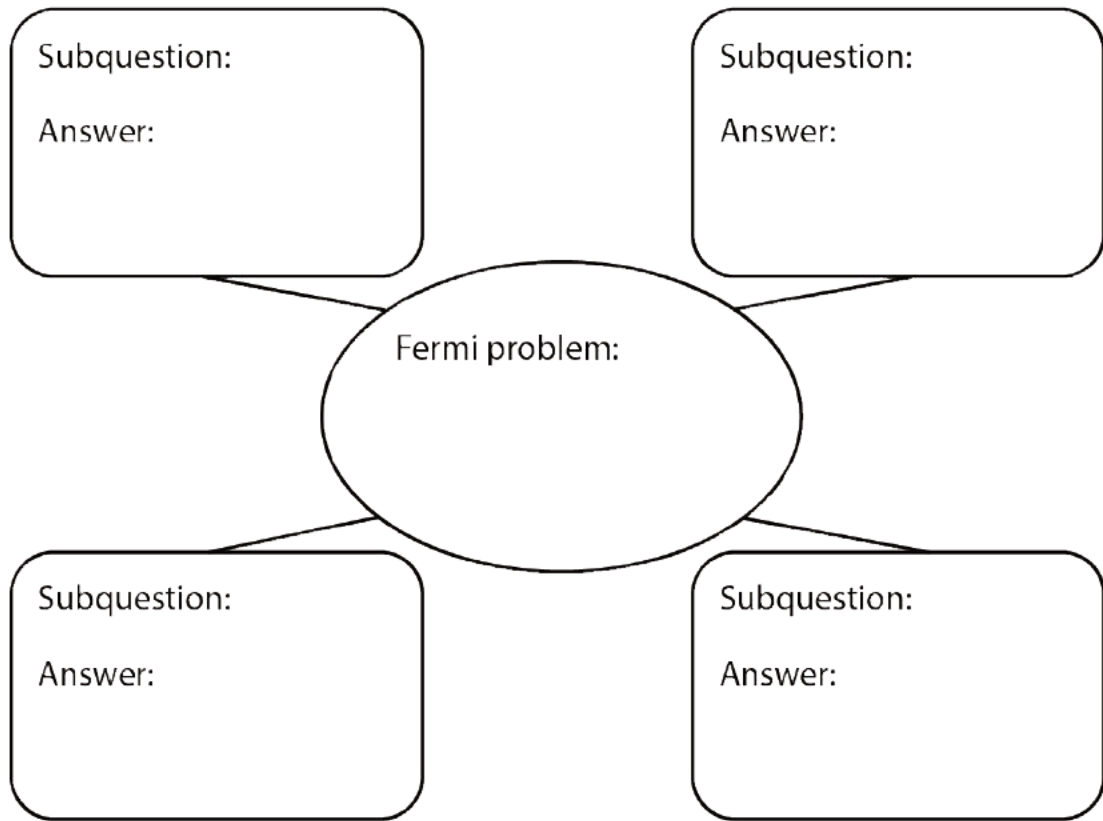

4. Find the information you need to get closer to answering your question. Measure, make estimates, and perform any necessary calculations. If you get stuck, consider using tables or double number line diagrams.
5. Create a visual display that includes your Fermi problem and your solution. Organize your thinking so it can be followed by others.

Student Response

Answers vary.

Activity Synthesis

Display students' posters or visual presentations throughout the classroom. Consider asking some students (or all, if time permits) to present their problems and solutions to the class. Notice and highlight instances of ratio and rate reasoning, particularly productive use of double number lines or tables.

Support for English Language Learners

Representing, Conversing: MLR7 Compare and Connect. Use this routine to prepare students for the whole-class discussion. Invite students to quietly circulate and read at least 2 of the posters or visual presentations in the room. Give students quiet think time to consider what is the same and what is different about the questions and displays. Next, ask students to find a partner to discuss what they noticed. Listen for, and amplify observations that include mathematical language and reasoning about double number lines or tables.

Design Principle(s): Cultivate conversation

Lesson Synthesis

The debrief and presentation of student work provides opportunities to summarize takeaways from this lesson. Aside from opportunities to point out how ratio reasoning and the use of representations can help us tackle difficult problems, this lesson makes explicit some aspects of mathematical modeling. Highlight instances where students had to make an estimate in order to proceed, figured out what additional information they would need to make progress, or made simplifying assumptions.

CKMath™
Core Knowledge **MATHEMATICS™**



Family Support
Materials

Family Support Materials

Introducing Ratios

Here are the video lesson summaries for Grade 6, Unit 2 Introducing Ratios. Each video highlights key concepts and vocabulary that students learn across one or more lessons in the unit. The content of these video lesson summaries is based on the written Lesson Summaries found at the end of lessons in the curriculum. The goal of these videos is to support students in reviewing and checking their understanding of important concepts and vocabulary. Here are some possible ways families can use these videos:

- Keep informed on concepts and vocabulary students are learning about in class.
- Watch with their student and pause at key points to predict what comes next or think up other examples of vocabulary terms (the bolded words).
- Consider following the Connecting to Other Units links to review the math concepts that led up to this unit or to preview where the concepts in this unit lead to in future units.

Grade 6, Unit 2: Introducing Ratios	Vimeo	YouTube
Video 1: What are Equivalent Ratios (Lessons 1–5)	Link	Link
Video 2: Double Number Line Diagrams (Lessons 6–8)	Link	Link
Video 3: Comparing Situations by Examining Ratios (Lessons 9–10)	Link	Link
Video 4: Tables of Equivalent Ratios (Lessons 11–14)	Link	Link
Video 5: Using Diagrams to Solve Ratio Problems (Lessons 15–16)	Link	Link

Video 1

Video 'VLS G6U2V1 What are Equivalent Ratios (Lessons 1–5)' available here:
<https://player.vimeo.com/video/455248778>.

Video 2

Video 'VLS G6U2V2 Double Number Line Diagrams (Lessons 6–8)' available here:
<https://player.vimeo.com/video/457996610>.

Video 3

Video 'VLS G6U2V3 Comparing Situations by Examining Ratios (Lessons 9–10)' available here: <https://player.vimeo.com/video/457998155>.

Video 4

Video 'VLS G6U2V4 Tables of Equivalent Ratios (Lessons 11–14)' available here:
<https://player.vimeo.com/video/458003339>.

Video 5

Video 'VLS G6U2V5 Using Diagrams to Solve Ratio Problems (Lessons 15–16)' available here: <https://player.vimeo.com/video/458004640>.

Connecting to Other Units

- *Coming soon*

What are Ratios?

Family Support Materials 1

A ratio is an association between two or more quantities. For example, say we have a drink recipe made with cups of juice and cups of soda water. Ratios can be represented with diagrams like those below.

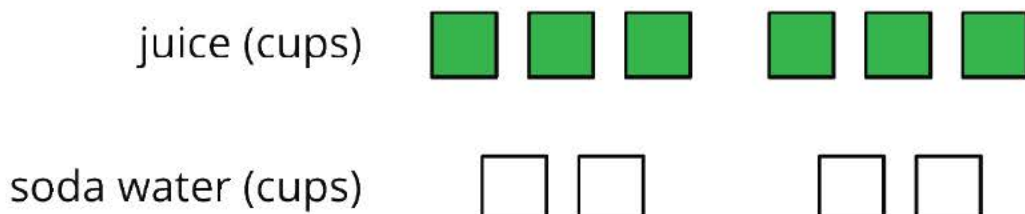

Here are some correct ways to describe this diagram:

- The ratio of cups of juice to cups of soda water is 6 : 4.
- The ratio of cups of soda water to cups of juice is 4 to 6.
- There are 3 cups of juice for every 2 cups of soda water.

The ratios 6 : 4, 3 : 2, and 12 : 8 are equivalent because each ratio of juice to soda water would make a drink that tastes the same.

Here is a task to try with your student:

There are 4 horses in a stall. Each horse has 4 legs, 1 tail, and 2 ears.

1. Draw a diagram that shows the ratio of legs, tails, and ears in the stall.
2. Complete each statement.
 - The ratio of _____ to _____ to _____ is _____ : _____ : _____.
 - There are _____ ears for every tail. There are _____ legs for every ear.

Solution:

1. Answers vary. Sample response:

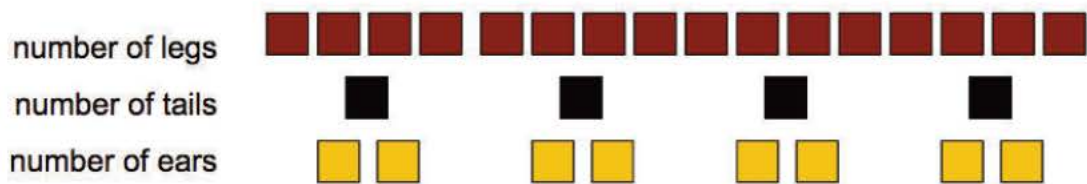

2. Answers vary. Sample response: The ratio of legs to tails to ears is 16 : 4 : 8. There are 2 ears for every tail. There are 2 legs for every ear.

Representing Equivalent Ratios

Family Support Materials 2

There are different ways to represent ratios.

Let's say the 6th grade class is selling raffle tickets at a price of \$6 for 5 tickets. Some students may use diagrams with shapes to represent the situation. For example, here is a diagram representing 10 tickets for \$12.

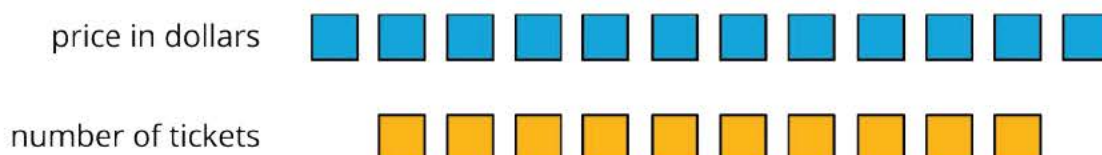

Drawing so many shapes becomes impractical. Double number line diagrams are easier to work with. The one below represents the price in dollars for different numbers of raffle tickets all sold *at the same rate* of \$12 for 10 tickets.

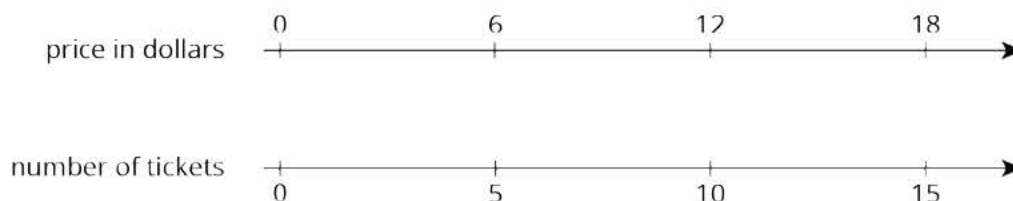

Here is a task to try with your student:

Raffle tickets cost \$6 for 5 tickets.

1. How many tickets can you get for \$90?
2. What is the price of 1 ticket?

Solution:

1. 75 tickets. Possible strategies: Extend the double number line shown and observe that \$90 is lined up with 75 tickets. Or, since 90 is 6 times 15, compute 5 times 15.
2. \$1.20. Possible strategies: Divide the number line into 5 equal intervals, as shown. Reason that the price in dollars of 1 ticket must be $6 \div 5$.

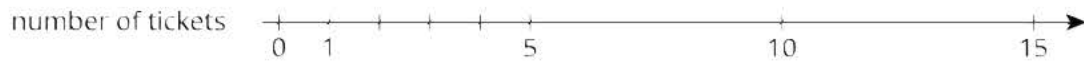
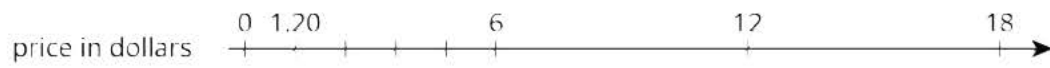

Solving Ratio and Rate Problems

Family Support Materials 3

Over the course of this unit, your student has learned to use the language of ratios and to work with ratios using representations like diagrams and double number lines. In the final sections of the unit, they use tables to organize equivalent ratios. Double number lines are hard to use in problems with large amounts. Let's think about an example we saw before: the 6th grade class is selling raffle tickets at a price of \$6 for 5 tickets. If we tried to extend the double number line below to represent the price of 300 raffle tickets, it would take 5 times more paper!

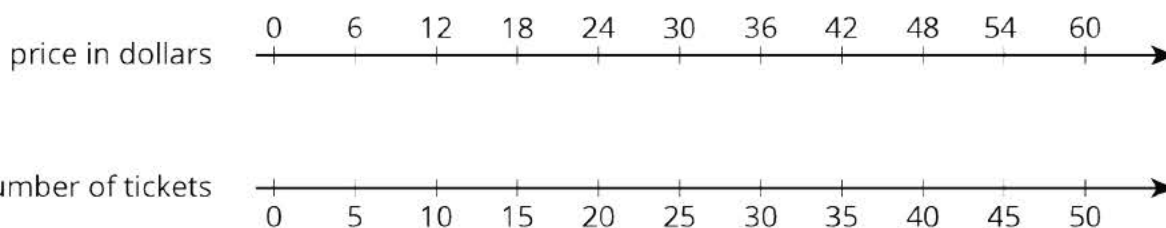

A table is a better choice to represent this situation. Tables of equivalent ratios are useful because you can arrange the rows in any order. For example, a student may find the price for 300 raffle tickets by making the table shown.

	price in dollars	number of tickets
$\div 5$	6	5
	1.20	1
$\cdot 300$	360	300

Annotations: On the left side, a curved arrow labeled $\div 5$ points from the first row to the second row, and another curved arrow labeled $\cdot 300$ points from the second row to the third row. On the right side, a curved arrow labeled $\div 5$ points from the first row to the second row, and another curved arrow labeled $\cdot 300$ points from the second row to the third row.

Although students can choose any representation that helps them solve a problem, it is important that they get comfortable with tables because they are used for a variety of purposes throughout high school and college mathematics courses.

Here is a task to try with your student:

At a constant speed, a train travels 45 miles in 60 minutes. At this rate, how far does the train travel in 12 minutes? If you get stuck, consider creating a table.

Solution:

9 miles. Possible strategy:

time in minutes	distance in miles
60	45
1	0.75
12	9

Unit Assessments

Check Your Readiness A and B
End-of-Unit Assessment A and B

Introducing Ratios: Check Your Readiness (A)

1. Here are three fractions: $\frac{2}{3}$, $\frac{4}{5}$, $\frac{6}{9}$. Two of these fractions are equivalent to each other. Which two? Explain or show your reasoning.

2. a. 28 is 7 times what number?
b. 8 is 32 times what number?
c. 4000 is 4 times what number?
d. Choose one part and explain how you know your answer is correct.

3. Label each tick mark with its location on the number line:

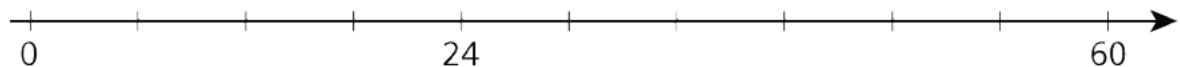

4. Here is a number line:

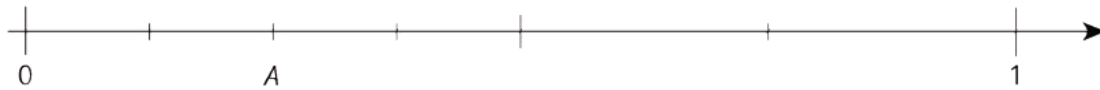

a. Write the number at A as a fraction.

b. Write the number at A as an equivalent fraction.

5. One batch of brownies calls for 1 box of brownie mix and the ingredients shown.

type of brownie	eggs	water	oil
fudge-like	2 eggs	$\frac{1}{4}$ cup	$\frac{1}{2}$ cup
cake-like	3 eggs	$\frac{1}{4}$ cup	$\frac{1}{2}$ cup

a. What amounts of eggs, water, and oil would you need for 2 batches of fudge-like brownies?

b. What amounts of eggs, water, and oil would you need for 3 batches of cake-like brownies?

6. Which travels faster: a car that travels 6 miles in 10 minutes at a constant speed, or a train that travels 6 miles in 8 minutes at a constant speed? Explain how you know.

Introducing Ratios: Check Your Readiness (B)

1. Here are three fractions: $\frac{3}{4}$, $\frac{5}{6}$, $\frac{6}{8}$. Two of these fractions are equivalent to each other.

Which two? Explain or show your reasoning.

2. a. 42 is 6 times what number?

b. 4 is 28 times what number?

c. 700 is 7 times what number?

d. Choose one part and explain how you know your answer is correct.

3. Label each tick mark with its location on the number line:

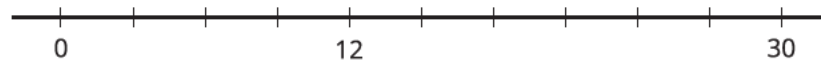

4. Here is a number line:

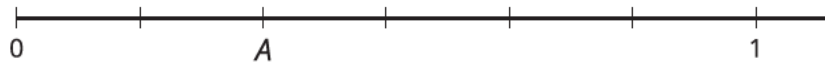

a. Write the number at A as a fraction.

b. Write the number at A as an equivalent fraction.

5. One batch of cookies calls for 1 bag of mix and the ingredients shown in the table.

type of cookie	eggs	water	oil
regular	1 egg	$\frac{1}{8}$	$\frac{1}{3}$
cake-like	2 eggs	$\frac{1}{8}$	$\frac{1}{3}$

a. What amounts of eggs, water, and oil would you need for 2 batches of regular cookies?

b. What amounts of eggs, water, and oil would you need for 3 batches of cake-like cookies?

6. Which skateboarder is faster: Jada, who travels 2 miles in 12 minutes at a constant speed, or Clare, who travels 2 miles in 10 minutes at a constant speed? Explain how you know.

Introducing Ratios: End-of-Unit Assessment (A)

1. Select all the true statements.

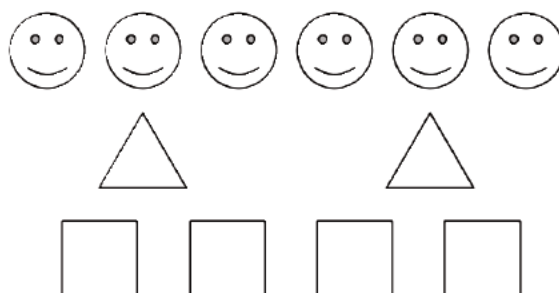

- A. The ratio of triangles to squares is 2 to 4.
- B. The ratio of squares to smiley faces is 6 : 4.
- C. The ratio of smiley faces to triangles is 6 to 4.
- D. There are two squares for every triangle.
- E. There are two triangles for every smiley face.
- F. There are three smiley faces for every triangle.

2. Select all the ratios that are equivalent to 8 : 6

- A. 4 : 3
- B. 6 : 8
- C. 16 : 12
- D. 10 : 8
- E. 7 : 5

3. A mixture of purple paint contains 6 teaspoons of red paint and 15 teaspoons of blue paint. To make the same shade of purple paint using 35 teaspoons of blue paint, how much red paint would you need? Use the double number line diagram to help if needed.

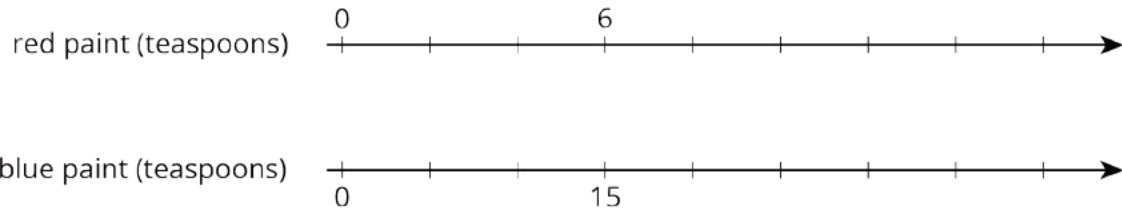

- A. 12 teaspoons
- B. 14 teaspoons
- C. 18 teaspoons
- D. 26 teaspoons

4. Lin rode her bike 2 miles in 8 minutes. She rode at a constant speed. Complete the table to show the time it took her to travel different distances at this speed.

distance traveled (miles)	elapsed time (minutes)
2	8
1	
	1

5. Solve each of the following:

a. 3 movie tickets cost \$36. At this rate, what is the cost per ticket?

b. 3 ice cream cones cost \$8.25. At this rate, how much do 2 ice cream cones cost?

c. 3 bananas cost \$0.99. At this rate, how much do 5 bananas cost?

6. A bag contains 120 marbles. Some are red and the rest are black. There are 19 red marbles for every black marble. How many red marbles are in the bag? Explain your reasoning.

7. To make orange fizz, Noah mixes 4 scoops of powder with 6 cups of water. Andre mixes 5 scoops of powder with 8 cups of water.

a. Create a double number line or a table that shows different amounts of powder and water that taste the same as Noah's mixture.

b. Create a double number line or a table that shows different amounts of powder and water that taste the same as Andre's mixture.

c. How do their two mixtures compare in taste? Explain your reasoning.

Introducing Ratios: End-of-Unit Assessment (B)

1. Select all the true statements.

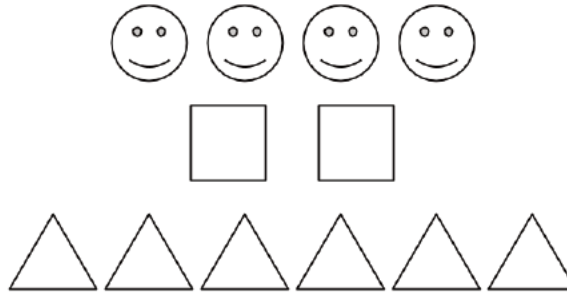

- A. The ratio of triangles to squares is 2 to 6.
- B. The ratio of squares to smiley faces is 2 : 4.
- C. The ratio of smiley faces to triangles is 4 to 2.
- D. There are three triangles for every square.
- E. There are two smiley faces for every square.
- F. There are two triangles for every smiley face.

2. Select all the ratios that are equivalent to 9 : 6.

- A. 6 : 9
- B. 3 : 2
- C. 13 : 10
- D. 5 : 2
- E. 18 : 12

3. A mixture of orange paint contains 8 teaspoons of red paint and 12 teaspoons of yellow paint. To make the same shade of orange paint using 18 teaspoons of red paint, how much yellow paint would you need? Use the double number line diagram to help if needed.

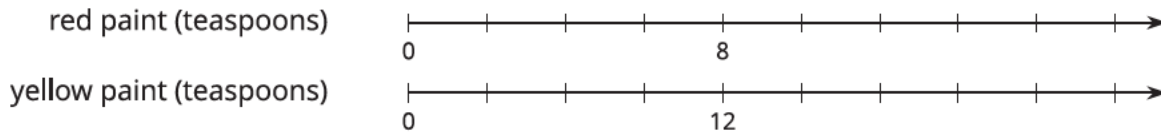

- A. 27 teaspoons
- B. 24 teaspoons
- C. 22 teaspoons
- D. 12 teaspoons
4. Elena rode her bike 2 miles in 10 minutes. She rode at a constant speed. Complete the table to show the time it took her to travel different distances at this speed.

distance traveled (miles)	elapsed time (minutes)
2	10
1	
	1

5. a. Three concert tickets cost \$45. At this rate, what is the cost per ticket?
- b. Three milkshakes cost \$9.75. At this rate, how much do 2 milkshakes cost?
- c. Three oranges cost \$1.35. At this rate, how much do 5 oranges cost?

6. A bag contains 150 marbles. Some are blue, and the rest are white. There are 21 blue marbles for every 4 white marbles. How many blue marbles are in the bag? Explain your reasoning.

7. To make fruit punch, Priya mixes 3 scoops of powder with 5 cups of water. Mai mixes 4 scoops of powder with 6 cups of water.

a. Create a double number line or a table that shows different amounts of powder and water that taste the same as Priya's mixture.

b. Create a double number line or a table that shows different amounts of powder and water that taste the same as Mai's mixture.

c. How do their two mixtures compare in taste? Explain your reasoning.

CKMath™
Core Knowledge **MATHEMATICS™**

Assessment Answer Keys

Check Your Readiness A and B
End-of-Unit Assessment A and B

Assessments

Assessment : Check Your Readiness (A)

Problem 1

The content assessed in this problem is first encountered in Lesson 6: Introducing Double Number Line Diagrams.

Students identify equivalent fractions and explain what it is that make the fractions equivalent. This concept ties in with nearly all the work in this unit and the next: equivalent ratios, scaling, and unit rates.

If most students struggle with this item, plan to use this item for some error analysis before beginning Lesson 6.

Statement

Here are three fractions: $\frac{2}{3}$, $\frac{4}{5}$, $\frac{6}{9}$. Two of these fractions are equivalent to each other. Which two? Explain or show your reasoning.

Solution

$\frac{2}{3}$ and $\frac{6}{9}$ are equivalent to each other. Possible strategies:

- 2 and 3 can be multiplied by 3 to get 6 and 9.
- Here is a diagram:



Aligned Standards

4.NF.A.1

Problem 2

The content assessed in this problem is first encountered in Lesson 2: Representing Ratios with Diagrams.

In their work with equivalent ratios, students will often need to consider questions of the form, “B is A times what number?” The second part of this question involves reasoning with fractions; the third part requires reasoning with place value.

If most students struggle with this item, plan to expand the discussion during Activity 1 Number Talk. As you synthesize the Number Talk consider including more related multiplication and division problems such as $24 \div 4 = 6$ and $4 \cdot 6 = 24$.

Statement

1. 28 is 7 times what number?
2. 8 is 32 times what number?
3. 4000 is 4 times what number?
4. Choose one part and explain how you know your answer is correct.

Solution

1. 4
2. $\frac{1}{4}$
3. 1000
4. Explanations vary.

Aligned Standards

4.NBT.A.1, 4.NF.B.4.b, 4.OA.A.1

Problem 3

The content assessed in this problem is first encountered in Lesson 7: Creating Double Number Line Diagrams.

Difficulty with placement of numbers and tick marks may be an indication that students need work with measurement conventions as discussed in the geometric measurement progression. This issue may need more instructional attention than what is currently given. In this case, students need to subdivide the number line into fourths to figure out how to mark the three equally spaced tick marks between 0 and 24. Students will use this skill when they study double number lines in the upcoming unit.

If most students struggle with this item, plan to expand Lesson 7 Activity 1, Ordering on a Number Line, by including a few examples of partitioning a number line.

Statement

Label each tick mark with its location on the number line:



Solution

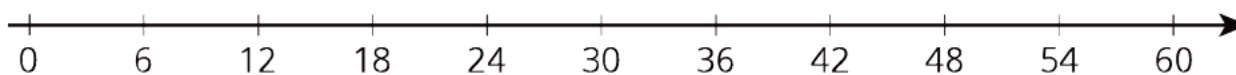

Aligned Standards

2.MD.B.6

Problem 4

The content assessed in this problem is first encountered in Lesson 7: Creating Double Number Line Diagrams.

This question is intended to assess whether the student understands that the interval from 0 to 1 must be partitioned into n parts of equal length in order for each subinterval to have length $\frac{1}{n}$.

If most students struggle with this item, plan to expand Lesson 7 Activity 1, Ordering on a Number Line, by including few examples of equivalent fractions.

Statement

Here is a number line:



1. Write the number at A as a fraction.
2. Write the number at A as an equivalent fraction.

Solution

1. $\frac{1}{4}$ (or equivalent)
2. $\frac{2}{8}$ (or equivalent, but different from previous answer)

Aligned Standards

3.NF.A.2, 3.NF.A.3.b

Problem 5

The content assessed in this problem is first encountered in Lesson 3: Recipes.

The two recipes in this problem contain the same ingredients, but in different amounts. Students will need to keep track of this information as they scale up the recipes. In addition to the conceptual work of scaling, this problem assesses students' comfort with multiplying a fraction by a whole number.

If most students struggle with this item, plan to do Activity 3, Batches of Cookies, to support their understanding of scaling using recipes. Then in Lesson 5 Activity 2, Tuna Casserole, students will practice multiplying a fraction times a whole number.

Statement

One batch of brownies calls for 1 box of brownie mix and the ingredients shown.

type of brownie	eggs	water	oil
fudge-like	2 eggs	$\frac{1}{4}$ cup	$\frac{1}{2}$ cup
cake-like	3 eggs	$\frac{1}{4}$ cup	$\frac{1}{2}$ cup

1. What amounts of eggs, water, and oil would you need for 2 batches of fudge-like brownies?
2. What amounts of eggs, water, and oil would you need for 3 batches of cake-like brownies?

Solution

1. 4 eggs, $\frac{1}{2}$ cup water, 1 cup oil (or equivalent)
2. 9 eggs, $\frac{3}{4}$ cup water, $1\frac{1}{2}$ cups oil (or equivalent)

Aligned Standards

4.NF.B.4.c

Problem 6

The content assessed in this problem is first encountered in Lesson 9: Constant Speed.

This problem assesses students' conceptual understanding of speed. The car and the train both travel the same distance, but the car takes longer to get there. The fact that a longer time results in a slower speed may seem counterintuitive to students who do not have a solid understanding. Students having difficulty may need more real-life examples to help make this idea plausible to them.

If most students struggle with this item, plan to share a few examples similar to the one in the assessment before launching Activity 2, Moving 10 Meters.

Statement

Which travels faster: a car that travels 6 miles in 10 minutes at a constant speed, or a train that travels 6 miles in 8 minutes at a constant speed? Explain how you know.

Solution

The train travels faster because it covers the same distance as the car in less time.

Aligned Standards

6.RP.A.3

Assessment : Check Your Readiness (B)

Problem 1

The content assessed in this problem is first encountered in Lesson 6: Introducing Double Number Line Diagrams.

Students identify equivalent fractions and explain what it is that make the fractions equivalent. This concept ties in with nearly all the work in this unit and the next—equivalent ratios, ratio tables, scaling, unit rates, and constants of proportionality.

If most students struggle with this item, plan to use this item for some error analysis before beginning Lesson 6.

Statement

Here are three fractions: $\frac{3}{4}$, $\frac{5}{6}$, $\frac{6}{8}$. Two of these fractions are equivalent to each other. Which two? Explain or show your reasoning.

Solution

$\frac{3}{4}$ and $\frac{6}{8}$ are equivalent to each other. Possible strategies:

- 3 and 4 can be multiplied by 2 to get 6 and 8.
- Here is a diagram:

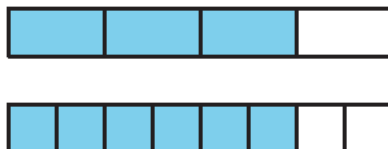

Aligned Standards

4.NF.A.1

Problem 2

The content assessed in this problem is first encountered in Lesson 2: Representing Ratios with Diagrams.

In their work with ratio and proportion, students will often need to consider questions of the form, “B is A times what number?” The second part of this question involves reasoning with fractions; the third part requires reasoning with place value.

If most students struggle with this item, plan to expand the discussion during Activity 1 Number Talk. As you synthesize the Number Talk consider including more related multiplication and division problems such as $24 \div 4 = 6$ and $4 \cdot 6 = 24$.

Statement

1. 42 is 6 times what number?
2. 4 is 28 times what number?
3. 700 is 7 times what number?
4. Choose one part and explain how you know your answer is correct.

Solution

1. 7
2. $\frac{1}{7}$
3. 100
4. Explanations vary.

Aligned Standards

4.NBT.A.1, 4.NF.B.4.b, 4.OA.A.1

Problem 3

The content assessed in this problem is first encountered in Lesson 7: Creating Double Number Line Diagrams.

Difficulty with placement of numbers and tick marks may be an indication that students need work with measurement conventions as discussed in the geometric measurement progression. This issue may need more instructional attention than what is currently given. In this case, students need to use proportional reasoning to figure out how to mark the three equally-spaced tick marks between 0 and 12. Students will use this skill when they study double number lines in the upcoming unit.

If most students struggle with this item, plan to expand Lesson 7 Activity 1, Ordering on a Number Line, by including a few examples of partitioning a number line.

Statement

Label each tick mark with its location on the number line:

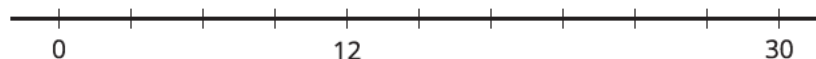

Solution

Each tick mark should be labeled with a multiple of 3 (3, 6, 9, 12, etc.).

Aligned Standards

2.MD.B.6

Problem 4

The content assessed in this problem is first encountered in Lesson 7: Creating Double Number Line Diagrams.

This question is intended to assess whether the student understands that the interval from 0 to 1 must be partitioned into n parts of equal length in order for each subinterval to have length $\frac{1}{n}$.

If most students struggle with this item, plan to expand Lesson 7 Activity 1, Ordering on a Number Line, by including few examples of equivalent fractions.

Statement

Here is a number line:

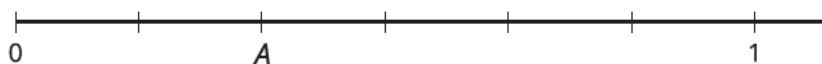

1. Write the number at A as a fraction.
2. Write the number at A as an equivalent fraction.

Solution

1. $\frac{1}{3}$ (or equivalent)
2. $\frac{2}{6}$ (or equivalent, but different from previous answer)

Aligned Standards

3.NF.A.2, 3.NF.A.3.b

Problem 5

The content assessed in this problem is first encountered in Lesson 3: Recipes.

The two recipes in this problem contain the same ingredients, but in different proportions. Students will need to keep track of this information as they scale up the recipes. In addition to the conceptual work of scaling, this problem assesses students' comfort with multiplying a fraction by a whole number.

If most students struggle with this item, plan to do Activity 3, Batches of Cookies, to support their understanding of scaling using recipes. Then in Lesson 5 Activity 2, Tuna Casserole, students will practice multiplying a fraction times a whole number.

Statement

One batch of cookies calls for 1 bag of mix and the ingredients shown in the table.

type of cookie	eggs	water	oil
regular	1 egg	$\frac{1}{8}$	$\frac{1}{3}$
cake-like	2 eggs	$\frac{1}{8}$	$\frac{1}{3}$

1. What amounts of eggs, water, and oil would you need for 2 batches of regular cookies?
2. What amounts of eggs, water, and oil would you need for 3 batches of cake-like cookies?

Solution

1. 2 eggs, $\frac{1}{4}$ cup water, $\frac{2}{3}$ cup oil (or equivalent)
2. 6 eggs, $\frac{3}{8}$ cup water, 1 cup oil (or equivalent)

Aligned Standards

4.NF.B.4.c

Problem 6

The content assessed in this problem is first encountered in Lesson 9: Constant Speed.

This problem assesses students' conceptual understanding of speed. Jada and Clare both skateboard the same distance, but Jada takes longer. The fact that a longer time results in a slower speed may seem counterintuitive to students who do not have a solid understanding. Students having difficulty may need more real-life examples to help make this idea plausible to them.

If most students struggle with this item, plan to share a few examples similar to the one in the assessment before launching Activity 2, Moving 10 Meters.

Statement

Which skateboarder is faster: Jada, who travels 2 miles in 12 minutes at a constant speed, or Clare, who travels 2 miles in 10 minutes at a constant speed? Explain how you know.

Solution

Clare is faster because she covers the same distance as Jada in less time.

Aligned Standards

6.RP.A.3

Assessment : End-of-Unit Assessment (A)

Problem 1

Students selecting B have the ratio backwards (6 : 4 vs. 4 : 6). Students failing to select any of A, D, or F may be confused about ratio language, either reversing the order of comparison or not understanding the general concept. Students selecting C might be mistakenly looking at the ratio of smiley faces to squares. Students selecting E are probably noticing that there are indeed two triangles, without understanding what “two triangles for every smiley face” means.

Statement

Select **all** the true statements.

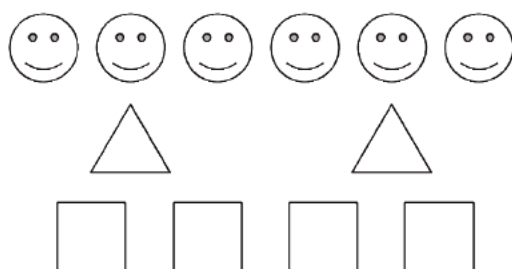

- A. The ratio of triangles to squares is 2 to 4.
- B. The ratio of squares to smiley faces is 6 : 4.
- C. The ratio of smiley faces to triangles is 6 to 4.
- D. There are two squares for every triangle.
- E. There are two triangles for every smiley face.
- F. There are three smiley faces for every triangle.

Solution

["A", "D", "F"]

Aligned Standards

6.RP.A.1

Problem 2

Students selecting B have the order of the ratio reversed. Students selecting D and E are mistakenly using a principle that pairs of numbers with a common difference (in this case, a difference of 2) will form equivalent ratios. Students failing to select A may think an equivalent ratio must use multiples of the numbers in the ratio. Students failing to select C have a clear misconception about the concept, or made an arithmetic error.

Statement

Select **all** the ratios that are equivalent to $8 : 6$

- A. $4 : 3$
- B. $6 : 8$
- C. $16 : 12$
- D. $10 : 8$
- E. $7 : 5$

Solution

["A", "C"]

Aligned Standards

6.RP.A.3

Problem 3

Students selecting A have doubled the amount of red paint, possibly because the amount of blue paint has approximately doubled. Students selecting C may be thinking that the tick marks on the top number line are spaced 3 units apart, when in fact they must be spaced 2 units apart. Students selecting D are either using a constant difference (instead of a constant ratio) between the blue and red paint, or (equivalently) are using a scale of 1 tick mark = 5 units for both number lines.

Statement

A mixture of purple paint contains 6 teaspoons of red paint and 15 teaspoons of blue paint. To make the same shade of purple paint using 35 teaspoons of blue paint, how much red paint would you need? Use the double number line diagram to help if needed.

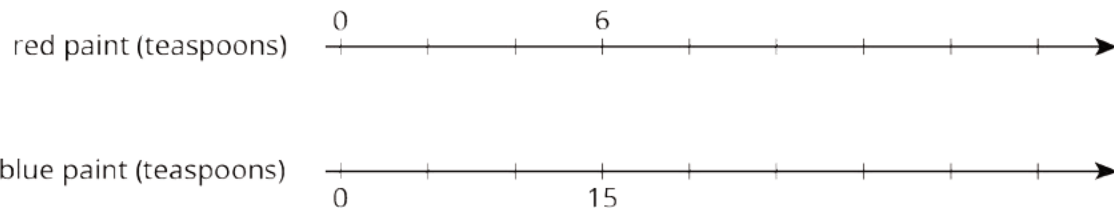

- A. 12 teaspoons
- B. 14 teaspoons
- C. 18 teaspoons
- D. 26 teaspoons

Solution

B

Aligned Standards

6.RP.A.3

Problem 4

This problem asks students to find two unit rates using a table—minutes per mile and miles per minute.

Statement

Lin rode her bike 2 miles in 8 minutes. She rode at a constant speed. Complete the table to show the time it took her to travel different distances at this speed.

distance traveled (miles)	elapsed time (minutes)
2	8
1	
	1

Solution

distance traveled (miles)	elapsed time (minutes)
2	8
1	4
$\frac{1}{4}$	1

Aligned Standards

6.RP.A.3

Problem 5

The numbers in this problem are messy enough that most students will need to calculate the unit price first, then multiply the unit price by the number of items. Look out for responses that involve calculating the unit price but do not go further.

Statement

Solve each of the following:

1. 3 movie tickets cost \$36. At this rate, what is the cost per ticket?
2. 3 ice cream cones cost \$8.25. At this rate, how much do 2 ice cream cones cost?
3. 3 bananas cost \$0.99. At this rate, how much do 5 bananas cost?

Solution

1. \$12
2. \$5.50
3. \$1.65

Aligned Standards

6.RP.A.2, 6.RP.A.3.b

Problem 6

Students will need to use some guesswork to find a pair of numbers that are in the correct ratio and that add up to 120.

Statement

A bag contains 120 marbles. Some are red and the rest are black. There are 19 red marbles for every black marble. How many red marbles are in the bag? Explain your reasoning.

Solution

114 red marbles. Explanations vary. Sample explanation: Make a table in which the first row has 19 red marbles and 1 black marble. We want to find the row where the total number of marbles is 120. Multiplying the first row by 6 gives 114 red marbles and 6 black marbles, which add to the correct total.

Minimal Tier 1 response:

- Work is complete and correct.
- Sample: $19 \cdot 6 = 114$, so there are 114 red marbles and 6 black marbles.

Tier 2 response:

- Work shows general conceptual understanding and mastery, with some errors.
- Sample errors: Red and black marbles are in the correct ratio but do not total 120; correct answer with no work shown and no explanation; work involves some correct reasoning about equivalent ratios with some errors.

Tier 3 response:

- Significant errors in work demonstrate lack of conceptual understanding or mastery.

- Sample errors: Work does not show evidence of an understanding of equivalent ratios; incorrect answer with no work shown.

Aligned Standards

6.RP.A.3

Problem 7

Make sure that students include at least two different powder/water combinations in their representations for each type of drink.

Statement

To make orange fizz, Noah mixes 4 scoops of powder with 6 cups of water. Andre mixes 5 scoops of powder with 8 cups of water.

1. Create a double number line or a table that shows different amounts of powder and water that taste the same as Noah's mixture.
2. Create a double number line or a table that shows different amounts of powder and water that taste the same as Andre's mixture.
3. How do their two mixtures compare in taste? Explain your reasoning.

Solution

Representations vary in both kind and in the numbers used. Sample response:

Noah's recipe

scoops of powder	cups of water
4	6
2	3
1	1.5

Andre's recipe

scoops of powder	cups of water
5	8
10	16
1	1.6

Noah's recipe tastes stronger. Sample reasoning: As shown in the tables, Noah's recipe uses less water for the same amount of powder.

Minimal Tier 1 response:

- Work is complete and correct, with complete explanation or justification.
- Acceptable errors: some mixing up of the terms "cup" and "scoop."
- Sample:

1. See table for Noah's recipe.
2. See table for Andre's recipe.
3. Noah's tastes stronger because for him, 1 cup of water needs $\frac{2}{3}$ of a scoop of powder, but for Andre, 1 cup of water needs only $\frac{5}{8}$ of a scoop of powder.

Tier 2 response:

- Work shows good conceptual understanding and mastery, with either minor errors or correct work with insufficient explanation or justification.
- Acceptable errors: a good explanation to part c is based on incorrect powder/water combinations found in parts a and b.
- Sample errors: arithmetic errors in otherwise reasonable tables/double number lines; explanation for part c is on track but leaves the reader to connect too many dots, e.g., "Noah's tastes stronger because $\frac{2}{3} > \frac{5}{8}$."

Tier 3 response:

- Work shows a developing but incomplete conceptual understanding, with significant errors.
- Acceptable errors: a good explanation to part c is based on incorrect powder/water combinations found in parts a and b.
- Sample errors: Representations in parts a and b do not show evidence of an understanding of equivalent ratios; correct representations in parts a and b but explanation in part c is missing or does not involve a comparison of unit rates.

Tier 4 response:

- Work includes major errors or omissions that demonstrate a lack of conceptual understanding and mastery.
- Sample errors: None of the work contains evidence of an understanding of equivalent ratios.

Aligned Standards

6.RP.A.1, 6.RP.A.3

Assessment : End-of-Unit Assessment (B)

Problem 1

Students selecting A have the ratio backwards (2 : 6 vs. 6 : 2). Students failing to select any of B, D, or E may be confused about ratio language, either reversing the order of comparison or not understanding the general concept. Students selecting C might be mistakenly looking at the ratio of smiley faces to squares. Students selecting F probably did not correctly count smiley faces to triangles. They see there are more triangles than smiley faces but do not accurately see that 4 to 6 cannot be equivalent to 1 to 2.

Statement

Select **all** the true statements.

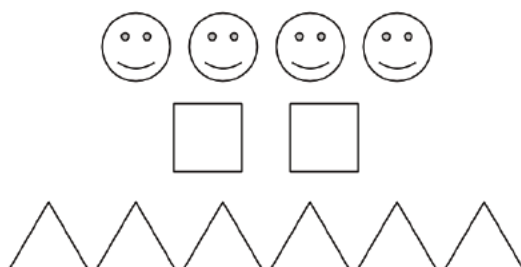

- A. The ratio of triangles to squares is 2 to 6.
- B. The ratio of squares to smiley faces is 2 : 4.
- C. The ratio of smiley faces to triangles is 4 to 2.
- D. There are three triangles for every square.
- E. There are two smiley faces for every square.
- F. There are two triangles for every smiley face.

Solution

["B", "D", "E"]

Aligned Standards

6.RP.A.1

Problem 2

Students selecting A have the order of the ratio reversed; possibly believing the reverse is equivalent. Students selecting C and D are mistakenly using the principle that pairs of numbers with a common difference (in this case, a difference of 4) will form equivalent ratios. Students failing to select B may think an equivalent ratio must use multiples of the numbers in the ratio. Students failing to select E have a clear misconception about the concept, or have made an arithmetic error.

Statement

Select **all** the ratios that are equivalent to 9 : 6.

- A. 6 : 9
- B. 3 : 2
- C. 13 : 10
- D. 5 : 2
- E. 18 : 12

Solution

["B", "E"]

Aligned Standards

6.RP.A.3

Problem 3

Students selecting D may have found the number of teaspoons of red, given 18 of yellow. Students selecting C are using a constant difference (instead of a constant ratio) between the red and yellow paint. Students selecting B have doubled the amount of yellow paint, possibly because the amount of red paint has approximately doubled.

Statement

A mixture of orange paint contains 8 teaspoons of red paint and 12 teaspoons of yellow paint. To make the same shade of orange paint using 18 teaspoons of red paint, how much yellow paint would you need? Use the double number line diagram to help if needed.

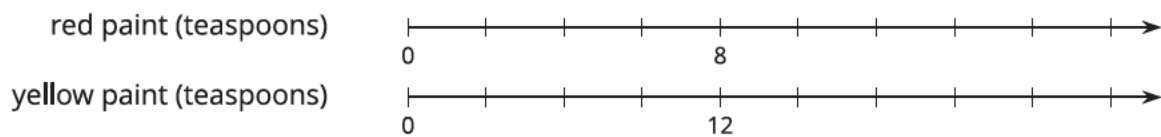

- A. 27 teaspoons
- B. 24 teaspoons
- C. 22 teaspoons
- D. 12 teaspoons

Solution

A

Aligned Standards

6.RP.A.3

Problem 4

This problem asks students to find two unit rates using a table—minutes per mile and miles per minute.

Statement

Elena rode her bike 2 miles in 10 minutes. She rode at a constant speed. Complete the table to show the time it took her to travel different distances at this speed.

distance traveled (miles)	elapsed time (minutes)
2	10
1	
	1

Solution

distance traveled (miles)	elapsed time (minutes)
2	10
1	5
$\frac{1}{5}$ or equivalent	1

Aligned Standards

6.RP.A.3

Problem 5

The numbers in this problem are messy enough that most students will need to calculate the unit price first, then multiply the unit price by the number of items. Look out for responses that involve calculating the unit price but do not go further.

Statement

1. Three concert tickets cost \$45. At this rate, what is the cost per ticket?
2. Three milkshakes cost \$9.75. At this rate, how much do 2 milkshakes cost?
3. Three oranges cost \$1.35. At this rate, how much do 5 oranges cost?

Solution

1. \$15
2. \$6.50
3. \$2.25

Aligned Standards

6.RP.A.2, 6.RP.A.3.b

Problem 6

Students will need to use some guesswork to find a pair of numbers that are in the correct ratio and add up to 150.

Statement

A bag contains 150 marbles. Some are blue, and the rest are white. There are 21 blue marbles for every 4 white marbles. How many blue marbles are in the bag? Explain your reasoning.

Solution

126 blue marbles. Explanations vary. Sample explanation: Make a table in which the first row has 21 blue marbles and 4 white marbles. We want to find the row where the total number of marbles is 150. Multiplying the first row by 6 gives 126 blue marbles and 24 white marbles, which add to the correct total of 150.

Minimal Tier 1 response:

- Work is complete and correct.
- Sample: $21 \cdot 6 = 126$, so there are 126 blue marbles and 24 white marbles.

Tier 2 response:

- Work shows general conceptual understanding and mastery, with some errors.
- Sample errors: blue and white marbles are in the correct ratio but do not total 150; correct answer with no work shown and no explanation; work involves some correct reasoning about equivalent ratios with some errors.

Tier 3 response:

- Significant errors in work demonstrate lack of conceptual understanding or mastery.
- Sample errors: Work does not show evidence of an understanding of equivalent ratios; incorrect answer with no work shown.

Aligned Standards

6.RP.A.3

Problem 7

Make sure students include at least two different powder/water combinations in their representations for each type of drink.

Statement

To make fruit punch, Priya mixes 3 scoops of powder with 5 cups of water. Mai mixes 4 scoops of powder with 6 cups of water.

1. Create a double number line or a table that shows different amounts of powder and water that taste the same as Priya's mixture.
2. Create a double number line or a table that shows different amounts of powder and water that taste the same as Mai's mixture.
3. How do their two mixtures compare in taste? Explain your reasoning.

Solution

Representations vary in both kind and in the numbers used. Sample response:

Priya's recipe

scoops of powder	cups of water
3	5
6	10
9	15
12	20

Mai's recipe

scoops of powder	cups of water
4	6
8	12
12	18

Mai's recipe tastes stronger. Sample reasoning: As shown in the tables, Mai's recipe uses less water for the same amount of powder at 12 scoops.

Minimal Tier 1 response:

- Work is complete and correct, with complete explanation or justification.
- Acceptable errors: some mixing up of the terms "cup" and "scoop."
- Sample:
 - See table for Priya's recipe.
 - See table for Mai's recipe.
 - Mai's tastes stronger because more powder is used per cup, 1 cup of water needs $\frac{2}{3}$ of a scoop of powder, but for Priya, 1 cup of water needs only $\frac{3}{5}$ of a scoop of powder and $\frac{2}{3}$ is greater than $\frac{3}{5}$.

Tier 2 response:

- Work shows good conceptual understanding and mastery, with either minor errors or correct work with insufficient explanation or justification.
- Acceptable errors: a good explanation to part c is based on incorrect powder/water combinations found in parts a and b.
- Sample errors: arithmetic errors in otherwise reasonable tables/double number lines; explanation for part c is on track but leaves the reader to connect too many dots, e.g., "Mai's tastes stronger because $\frac{2}{3} > \frac{3}{5}$."

Tier 3 response:

- Work shows a developing but incomplete conceptual understanding, with significant errors.
- Acceptable errors: a good explanation to part c is based on incorrect powder/water combinations found in parts a and b.
- Sample errors: Representations in parts a and b do not show evidence of an understanding of equivalent ratios; correct representations in parts a and b but explanation in part c is missing or does not involve a comparison of unit rates.

Tier 4 response:

- Work includes major errors or omissions that demonstrate a lack of conceptual understanding and mastery.
- Sample errors: None of the work contains evidence of an understanding of equivalent ratios.

Aligned Standards

6.RP.A.1, 6.RP.A.3

CKMath[™]
Core Knowledge **MATHEMATICS**[™]



Lesson
Cool Downs

Lesson 1: Introducing Ratios and Ratio Language

Cool Down: A Collection of Animals

Here is a collection of dogs, mice, and cats:

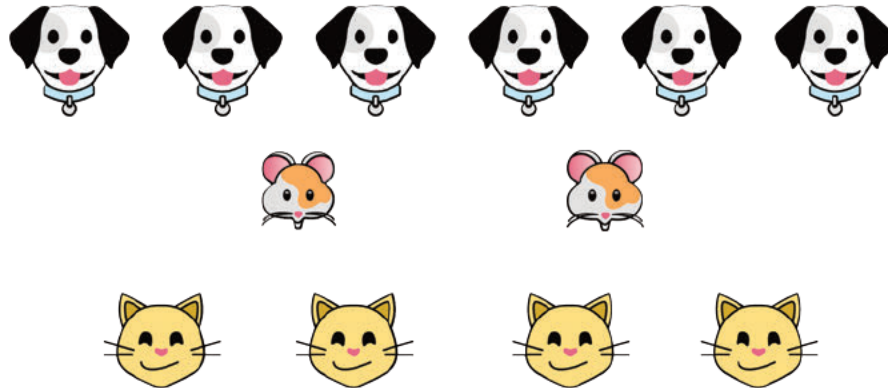

Write *two* sentences that describe a ratio of types of animals in this collection.

Lesson 2: Representing Ratios with Diagrams

Cool Down: Paws, Ears, and Tails

There are 3 cats in a room and no other creatures. Each cat has 2 ears, 4 paws, and 1 tail.



1. Draw a diagram that shows an association between numbers of ears, paws, and tails in the room.

2. Complete each statement:

- a. The ratio of _____ to _____ to _____ is _____ : _____ : _____.
- b. There are _____ paws for every tail.
- c. There are _____ paws for every ear.

Lesson 3: Recipes

Cool Down: A Smaller Batch of Bird Food

Usually when Elena makes bird food, she mixes 9 cups of seeds with 6 tablespoons of maple syrup. However, today she is short on ingredients. Think of a recipe that would yield a smaller batch of bird food but still taste the same. Explain or show your reasoning.

Lesson 4: Color Mixtures

Cool Down: Orange Water

A recipe for orange water says, "Mix 3 teaspoons yellow water with 1 teaspoon red water." For this recipe, we might say: "The ratio of teaspoons of yellow water to teaspoons of red water is 3 : 1."

1. Write a ratio for 2 batches of this recipe.
2. Write a ratio for 4 batches of this recipe.
3. Explain why we can say that any two of these three ratios are equivalent.

Lesson 6: Introducing Double Number Line Diagrams

Cool Down: Batches of Cookies on a Double Number Line

A recipe for one batch of cookies uses 5 cups of flour and 2 teaspoons of vanilla.

1. Complete the double number line diagram to show the amount of flour and vanilla needed for 1, 2, 3, 4, and 5 batches of cookies.

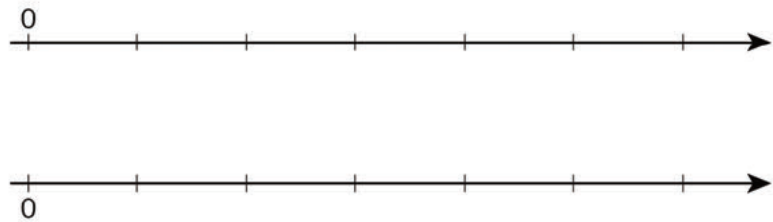

2. If you use 20 cups of flour, how many teaspoons of vanilla should you use?
3. If you use 6 teaspoons of vanilla, how many cups of flour should you use?

Lesson 7: Creating Double Number Line Diagrams

Cool Down: Revisiting Paws, Ears, and Tails

Each of these cats has 2 ears, 4 paws, and 1 tail.

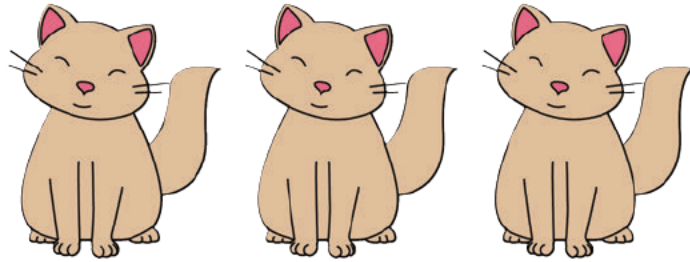

1. Draw a double number line diagram that represents a ratio in the situation.

2. Write a sentence that describes this situation and that uses the word *per*.

Lesson 8: How Much for One?

Cool Down: Unit Price of Rice

Here is a double number line showing that it costs \$3 to buy 2 bags of rice:

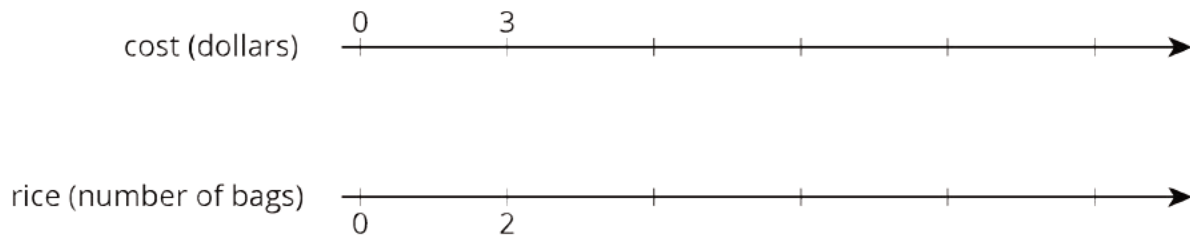

1. At this rate, how many bags of rice can you buy with \$12?
2. Find the cost per bag.
3. How much do 20 bags of rice cost?

Lesson 9: Constant Speed

Cool Down: Train Speeds

Two trains are traveling at constant speeds on different tracks.

Train A:

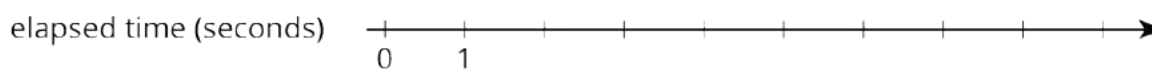

Train B:

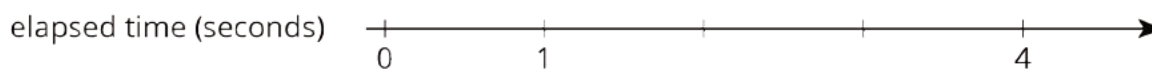
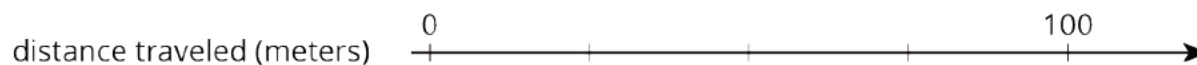

Which train is traveling faster? Explain your reasoning.

Lesson 10: Comparing Situations by Examining Ratios

Cool Down: Comparing Runs

Andre ran 2 kilometers in 15 minutes, and Jada ran 3 kilometers in 20 minutes. Both ran at a constant speed.

Did they run at the *same* speed? Explain your reasoning.

Lesson 11: Representing Ratios with Tables

Cool Down: Batches of Cookies in a Table

In previous lessons, we worked with a diagram and a double number line that represent this cookie recipe. Here is a table that represents the same situation.

flour (cups)	vanilla (teaspoons)
5	2
15	6
$2\frac{1}{2}$	1

1. Write a sentence that describes a ratio shown in the table.
2. What does the second row of numbers represent?
3. Complete the last row for a different batch size that hasn't been used so far in the table. Explain or show your reasoning.

Lesson 12: Navigating a Table of Equivalent Ratios

Cool Down: Price of Bagels

A shop sells bagels for \$5 per dozen. You can use the table to answer the questions. Explain your reasoning.

number of bagels	price in dollars
12	5

1. At this rate, how much would 6 bagels cost?

2. How many bagels can you buy for \$50?

Lesson 13: Tables and Double Number Line Diagrams

Cool Down: Bicycle Sprint

In a sprint to the finish, a professional cyclist travels 380 meters in 20 seconds. At that rate, how far does the cyclist travel in 3 seconds?

Lesson 14: Solving Equivalent Ratio Problems

Cool Down: Water Faucet

Jada wants to know how fast the water comes out of her faucet. What information would she need to know to be able to determine that?

Lesson 15: Part-Part-Whole Ratios

Cool Down: Room Sizes

The first floor of a house consists of a kitchen, playroom, and dining room. The areas of the kitchen, playroom, and dining room are in the ratio 4 : 3 : 2. The combined area of these three rooms is 189 square feet. What is the area of each room?

CKMath™
Core Knowledge **MATHEMATICS™**



Instructional
Masters

Instructional Masters for Introducing Ratios

address	title	students per copy	written on?	requires cutting?	card stock recommended?	color paper recommended?
Activity Grade6.2.14.2	Info Gap: Hot Chocolate and Potatoes	4	no	yes	no	no
Activity Grade6.2.16.3	Salad Dressing and Moving Boxes	4	no	yes	no	no
Activity Grade6.2.2.4	Card Sort: Spaghetti Sauce	2	no	yes	no	yes
Activity Grade6.2.13.3	The International Space Station	4	yes	yes	no	no

6.2.2.4 Card Sort: Spaghetti Sauce.

Card Sort: Spaghetti Sauce

Diagram A

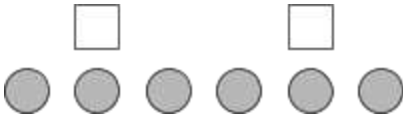

Card Sort: Spaghetti Sauce

Sentence 4

There are 3 cups of tomato sauce for every tablespoon of oil.

Card Sort: Spaghetti Sauce

Diagram B

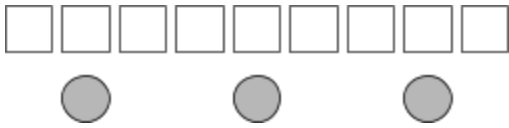

Card Sort: Spaghetti Sauce

Sentence 2

There are 3 tablespoons of oil for every cup of tomato sauce.

The above diagram also matches this sentence.

Card Sort: Spaghetti Sauce

Sentence 8

The ratio of cups of tomato sauce to tablespoons of oil is 1 : 3.

Card Sort: Spaghetti Sauce

Diagram C

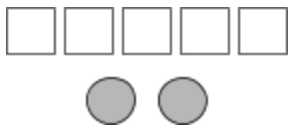

Card Sort: Spaghetti Sauce

Sentence 1

The ratio of tablespoons of oil to cups of tomato sauce is 5 to 2.

Card Sort: Spaghetti Sauce

Diagram D

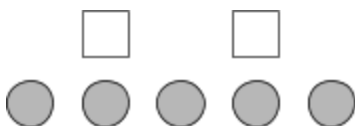

Card Sort: Spaghetti Sauce

Sentence 5

The ratio of cups of tomato sauce to tablespoons of oil is 5 to 2.

6.2.2.4 Card Sort: Spaghetti Sauce.

Card Sort: Spaghetti Sauce

Diagram E

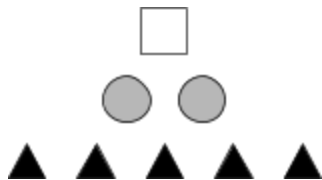

Card Sort: Spaghetti Sauce

Sentence 3

For every tablespoon of oil, there are 2 cups of tomato sauce and 5 teaspoons of oregano.

The above diagram also matches this sentence.

Card Sort: Spaghetti Sauce

Sentence 7

Tablespoons of oil, teaspoons of oregano, and cups of tomato sauce are in the ratio 1 : 5 : 2.

Card Sort: Spaghetti Sauce

Diagram F

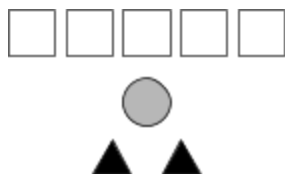

Card Sort: Spaghetti Sauce

Sentence 6

Cups of tomato sauce, tablespoons of oil, and teaspoons of oregano are in the ratio 1 : 5 : 2.

6.2.13.3 The International Space Station.

The International Space Station

distance traveled	elapsed time (seconds)
0	0
80	10
	1

The International Space Station

distance traveled	elapsed time (seconds)
0	0
80	10
	1

The International Space Station

distance traveled (km)

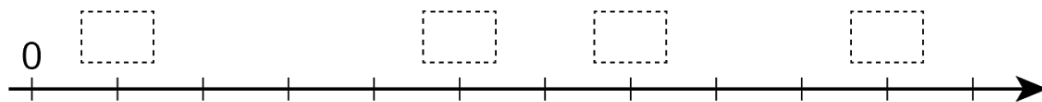

elapsed time

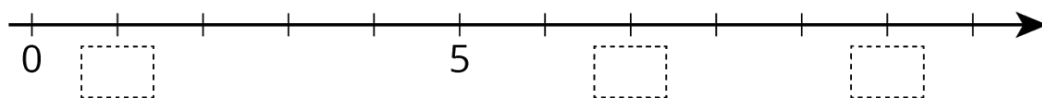

The International Space Station

distance traveled (km)

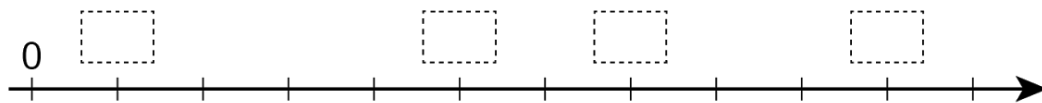

elapsed time

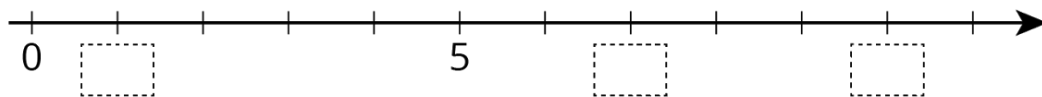

Info Gap: Hot Chocolate and Potatoes

Problem Card 1

Jada mixes milk and cocoa powder to make hot chocolate. She wants to use all of the cocoa powder she has left. How much milk should Jada use?

Info Gap: Hot Chocolate and Potatoes

Data Card 1

- Jada's recipe calls for 3 cups of milk.
- Jada's recipe calls for 2 tablespoons of cocoa powder.
- Jada has 2 gallons of milk.
- Jada has 9 tablespoons of cocoa powder
- There are 16 cups in 1 gallon.

Info Gap: Hot Chocolate and Potatoes

Problem Card 2

Noah needs to peel a lot of potatoes before a large dinner. He has already peeled some potatoes. If Noah keeps peeling at the same rate, will he finish all the potatoes in time?

Info Gap: Hot Chocolate and Potatoes

Data Card 2

- Noah has already peeled 8 potatoes.
- Noah has been peeling for 10 minutes.
- Noah needs to peel 60 more potatoes.
- Noah needs to be finished peeling in 1 hour and 10 minutes.
- There are 60 minutes in 1 hour.

Info Gap: Hot Chocolate and Potatoes

Problem Card 1

Jada mixes milk and cocoa powder to make hot chocolate. She wants to use all of the cocoa powder she has left. How much milk should Jada use?

Info Gap: Hot Chocolate and Potatoes

Data Card 1

- Jada's recipe calls for 3 cups of milk.
- Jada's recipe calls for 2 tablespoons of cocoa powder.
- Jada has 2 gallons of milk.
- Jada has 9 tablespoons of cocoa powder
- There are 16 cups in 1 gallon.

Info Gap: Hot Chocolate and Potatoes

Problem Card 2

Noah needs to peel a lot of potatoes before a large dinner. He has already peeled some potatoes. If Noah keeps peeling at the same rate, will he finish all the potatoes in time?

Info Gap: Hot Chocolate and Potatoes

Data Card 2

- Noah has already peeled 8 potatoes.
- Noah has been peeling for 10 minutes.
- Noah needs to peel 60 more potatoes.
- Noah needs to be finished peeling in 1 hour and 10 minutes.
- There are 60 minutes in 1 hour.

Salad Dressing and Moving Boxes

Problem Card 1

A recipe for salad dressing uses oil and vinegar. Clare made a certain amount of this dressing. How much oil did she use?

Salad Dressing and Moving Boxes

Data Card 1

- The recipe calls for 4 parts oil.
- The recipe calls for 3 parts vinegar.
- The ratio of oil to vinegar in the recipe is 4 : 3.
- The ratio of vinegar to oil in the recipe is 3 : 4.
- Clare made a total of 28 teaspoons of dressing.

Salad Dressing and Moving Boxes

Problem Card 2

Andre and Han are moving boxes, each working at a constant rate. How long will it take Andre and Han to move all the boxes?

Salad Dressing and Moving Boxes

Data Card 2

- Andre can move 4 boxes every half hour.
- Han can move 5 boxes every half hour.
- The ratio of boxes moved by Andre to boxes moved by Han is 4 : 5.
- The ratio of boxes moved by Han to boxes moved by Andre is 5 : 4.
- There are 72 boxes that need to be moved.

Salad Dressing and Moving Boxes

Problem Card 1

A recipe for salad dressing uses oil and vinegar. Clare made a certain amount of this dressing. How much oil did she use?

Salad Dressing and Moving Boxes

Data Card 1

- The recipe calls for 4 parts oil.
- The recipe calls for 3 parts vinegar.
- The ratio of oil to vinegar in the recipe is 4 : 3.
- The ratio of vinegar to oil in the recipe is 3 : 4.
- Clare made a total of 28 teaspoons of dressing.

Salad Dressing and Moving Boxes

Problem Card 2

Andre and Han are moving boxes, each working at a constant rate. How long will it take Andre and Han to move all the boxes?

Salad Dressing and Moving Boxes

Data Card 2

- Andre can move 4 boxes every half hour.
- Han can move 5 boxes every half hour.
- The ratio of boxes moved by Andre to boxes moved by Han is 4 : 5.
- The ratio of boxes moved by Han to boxes moved by Andre is 5 : 4.
- There are 72 boxes that need to be moved.

Credits

CKMath K–8 was originally developed by Open Up Resources and authored by Illustrative Mathematics, <https://www.illustrativemathematics.org>, and is copyrighted as 2017–2019 by Open Up Resources. It is licensed under the Creative Commons Attribution 4.0 International License (CC BY 4.0). The Open Up Resources K–8 Math Curriculum is available at: <https://www.openupresources.org/math-curriculum/>.

Adaptations and updates to the IM K–8 Math English language learner supports are copyright 2019 by Open Up Resources and licensed under the Creative Commons Attribution 4.0 International License (CC BY 4.0),

Adaptations and updates to IM K–8 Math are copyright 2019 by Illustrative Mathematics, including the additional English assessments marked as "B", and the Spanish translation of assessments marked as "B". These adaptations and updates are licensed under the Creative Commons Attribution 4.0 International License (CC BY 4.0).

This particular work is based on additional work of the Core Knowledge® Foundation (www.coreknowledge.org) made available through licensing under a Creative Commons Attribution-NonCommercial-ShareAlike 4.0 International License.

Illustration and Photo Credits

Ivan Pestic / Cover Illustrations

Illustrative Math K–8 / Cover Image, all interior illustrations, diagrams, and pictures / Copyright 2019 / Licensed under the Creative Commons Attribution 4.0 International License (CC BY 4.0).

These materials include public domain images or openly licensed images that are copyrighted by their respective owners, unless otherwise noted/credited. Openly licensed images remain under the terms of their respective licenses.



CKMath™
Core Knowledge **MATHEMATICS™**

Editorial Director
Richard B. Talbot

CKMath™
Core Knowledge MATHEMATICS™

A comprehensive program for mathematical skills and concepts
as specified in the **Core Knowledge Sequence**
(content and skill guidelines for Grades K–8).

Core Knowledge MATHEMATICS™
units at this level include:

Area and Surface Area
Introducing Ratios
Unit Rates and Percentages
Dividing Fractions
Arithmetic in Base Ten
Expressions and Equations
Rational Numbers
Data Sets and Distributions
Putting it All Together

www.coreknowledge.org

Core Knowledge Curriculum Series™