

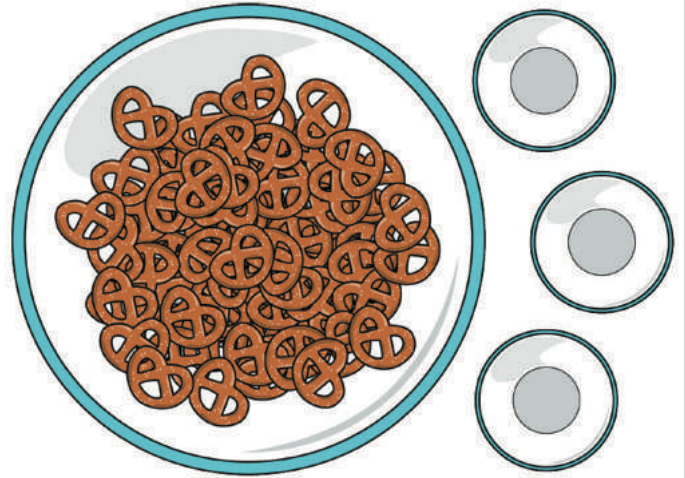

Core Knowledge[®] MATHEMATICS

Multiplying and Dividing Fractions



Teacher Guide



Creative Commons Licensing

This work is licensed under a Creative Commons Attribution-NonCommercial-ShareAlike 4.0 International License.



You are free:

to Share—to copy, distribute, and transmit the work

to Remix—to adapt the work

Under the following conditions:

Attribution—You must attribute the work in the following manner:

CKMath 6–8 was originally developed by Open Up Resources and authored by Illustrative Mathematics, <https://www.illustrativemathematics.org>, and is copyrighted as 2017–2019 by Open Up Resources. It is licensed under the Creative Commons Attribution 4.0 International License (CC BY 4.0). The Open Up Resources 6–8 Math Curriculum is available at: <https://www.openupresources.org/math-curriculum/>.

Adaptations and updates to the IM 6–8 Math English language learner supports and the additional English assessments marked as "B" are copyright 2019 by Open Up Resources and licensed under the Creative Commons Attribution 4.0 International License (CC BY 4.0).

Adaptations and updates to the IM K–8 Math Spanish translation of assessments marked as "B" are copyright 2019 by Illustrative Mathematics. These adaptations and updates are licensed under the Creative Commons Attribution 4.0 International License (CC BY 4.0).

This particular work is based on additional work of the Core Knowledge® Foundation (www.coreknowledge.org) made available through licensing under a Creative Commons Attribution-Non Commercial-Share Alike 4.0 International License. This does not in any way imply that the Core Knowledge Foundation endorses this work.

Noncommercial—You may not use this work for commercial purposes.

Share Alike—If you alter, transform, or build upon this work, you may distribute the resulting work only under the same or similar license to this one.

With the understanding that:

For any reuse or distribution, you must make clear to others the license terms of this work. The best way to do this is with a link to this web page:

<https://creativecommons.org/licenses/by-nc-sa/4.0/>

Copyright © 2023 Core Knowledge Foundation

www.coreknowledge.org

All Rights Reserved.

Core Knowledge®, Core Knowledge Curriculum Series™, Core Knowledge Math™ and CKMath™ are trademarks of the Core Knowledge Foundation.

Trademarks and trade names are shown in this book strictly for illustrative and educational purposes and are the property of their respective owners. References herein should not be regarded as affecting the validity of said trademarks and trade names.

ISBN: 979-8-88970-895-7

Multiplying and Dividing Fractions

Table of Contents

Introduction	i
Unit Overview	1
Section Overview	2
Center Overview	10
Lessons Plans and Student Task Statements:	
Section A: Lessons 1–9 Fraction Multiplication	22
Section B: Lessons 10–16 Fraction Division	96
Section C: Lessons 17–20 Problem Solving with Fractions ...	152
Teacher Resources	184
Family Support Materials	
Assessments	
Cool Downs	
Instructional Masters	

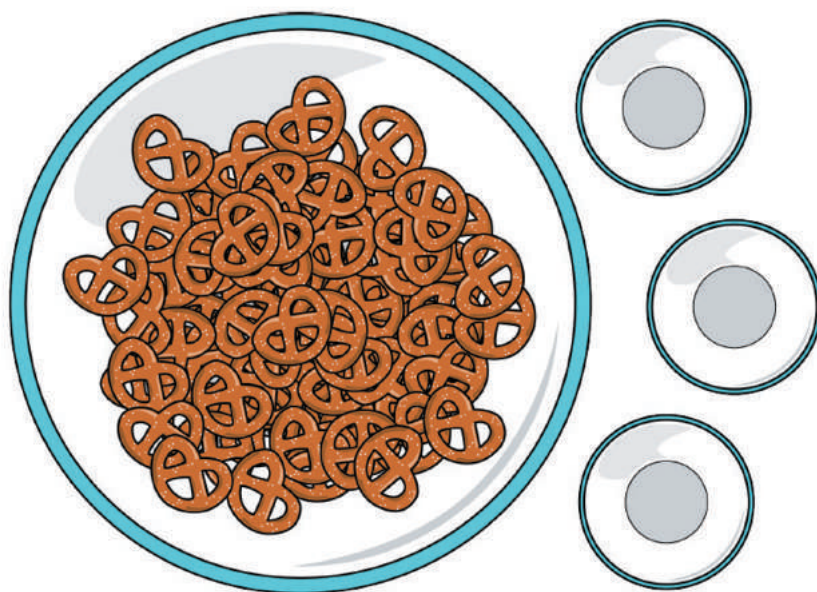

Multiplying and Dividing Fractions Teacher Guide

Core Knowledge Mathematics™

Unit 3: Multiplying and Dividing Fractions

At a Glance

Unit 3 is estimated to be completed in 19-22 days including 2 days for assessment.

This unit is divided into three sections including 17 lessons and 3 optional lessons.

- Section A—Fraction Multiplication (Lessons 1-9)
- Section B—Fraction Division (Lessons 10-16)
- Section C—Problem Solving with Fractions (Lessons 17-20)

On pages 8-9 of this Teacher Guide is a chart that identifies the section each lesson belongs in and the materials needed for each lesson.

This unit uses four student centers.

- Rolling for Fractions
- Five in a Row: Multiplication
- How Close?
- Compare

Unit 3: Multiplying and Dividing Fractions

Unit Learning Goals

- Students extend multiplication and division of whole numbers to multiply fractions by fractions and divide a whole number and a unit fraction.

In this unit, students find the product of two fractions, divide a whole number by a unit fraction, and divide a unit fraction by a whole number.

Previously, students made sense of multiplication of a whole number and a fraction in terms of the side lengths and area of a rectangle. Here, they make sense of multiplication of two fractions the same way. Students interpret area diagrams with two unit fractions for their side lengths, then a unit fraction and a non-unit fraction, and then two non-unit fractions.

Through repeated reasoning, students notice regularity in the value of the product (MP8). They generalize that it can be found by multiplying the numerators and multiplying the denominators of the factors:

$$\frac{a}{b} \times \frac{c}{d} = \frac{a \times c}{b \times d}$$

For example, $\frac{2}{4} \times \frac{3}{5}$ is $\frac{2 \times 3}{4 \times 5}$ because there are 4×5 equal parts in the whole square and 2×3 parts are shaded.

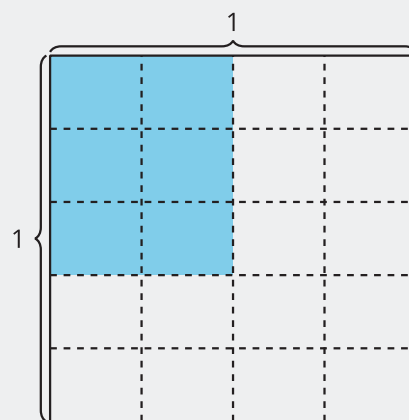

Next, students make sense of division situations and expressions that involve a whole number and a unit fraction. They recall that division can be understood in terms of finding the number of equal-size groups or finding the size of each group.

For instance, students interpret $\frac{1}{3} \div 4$ to mean finding the size of one part if $\frac{1}{3}$ is split into 4 equal parts, and $4 \div \frac{1}{3}$ to mean finding how many $\frac{1}{3}$ s are in 4.

Students consider how changing the dividend or the divisor changes the value of the quotients and look for patterns (MP8). They use tape diagrams to represent and reason about division situations and expressions.

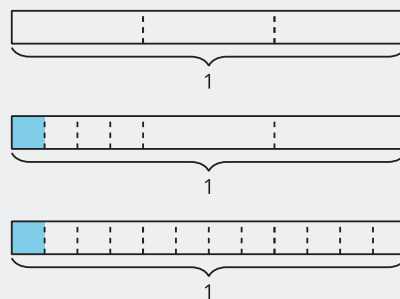

Later in the unit, students apply what they learned to solve problems. The relationship between multiplication and division is reinforced when they notice that both operations can be used to solve the same problem.

Section A: Fraction Multiplication

Standards Alignments

Addressing 5.NF.B.4, 5.NF.B.4.a, 5.NF.B.4.b, 5.NF.B.6

Building Towards 5.NF.B.4, 5.NF.B.4.a, 5.NF.B.4.b, 5.NF.B.6

Section Learning Goals

- Recognize that $\frac{a}{b} \times \frac{c}{d} = \frac{a \times c}{b \times d}$ and use this generalization to multiply fractions numerically.
- Represent and describe multiplication of a fraction by a fraction using area concepts.

In this section, students reason about multiplication of two fractions. They begin by considering situations that involve finding a fraction of a fraction. They represent the situations by drawing diagrams that make sense to them.

For example, “A pan of macaroni and cheese is $\frac{1}{3}$ full. Kiran eats $\frac{1}{4}$ of the macaroni and cheese. How much of the whole pan did Kiran eat?”

By partitioning the first third of a pan into fourths and doing the same with the other two thirds, students can see that Kiran ate $\frac{1}{12}$ of the whole pan.

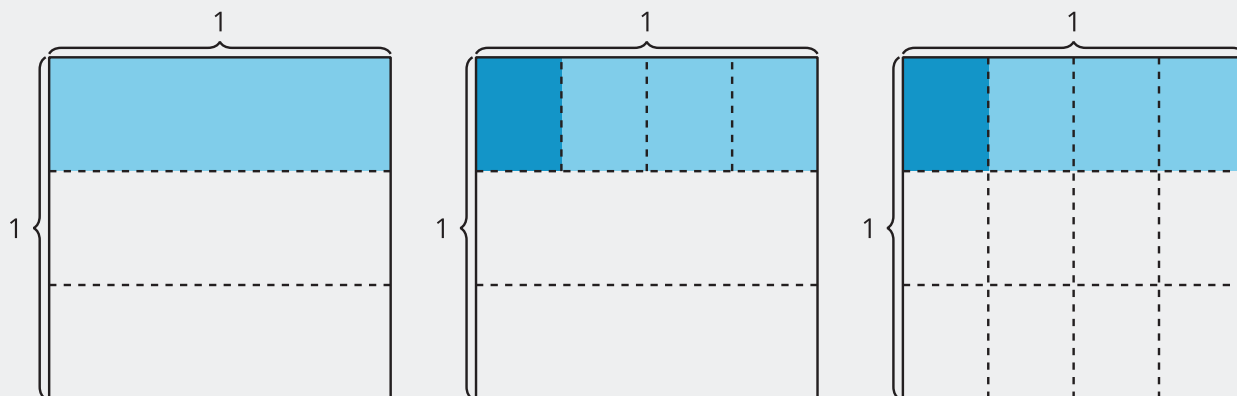

Students connect the product of two fractions to the area of a rectangle with fractional side lengths. When multiplying unit fractions, students see the denominator as the number of equal parts in the unit square, structured as an array. So partitioning one side of a rectangle into fourths and the other into thirds create a 4-by-3 array. Each part in the array is $\frac{1}{12}$ of 1 whole.

The area of a rectangle that is $\frac{1}{4}$ by $\frac{1}{3}$ is thus $\frac{1}{12}$, or $\frac{1}{4} \times \frac{1}{3} = \frac{1}{4 \times 3} = \frac{1}{12}$. Students generalize this as:

$$\frac{1}{b} \times \frac{1}{d} = \frac{1}{b \times d}$$



They extend this insight to find the product of non-unit fractions, including fractions greater than 1.

For example, the value of $\frac{3}{4} \times \frac{7}{5}$ is

$\frac{3 \times 7}{4 \times 5}$ because 3×7 parts are shaded and there are 4×5 equal parts in 1 whole.

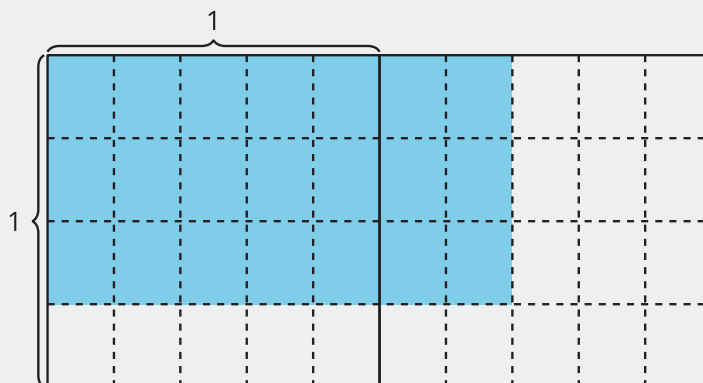
$$\frac{a}{b} \times \frac{c}{d} = \frac{a \times c}{b \times d}$$



 ↔  PLC: Lesson 3, Activity 1, Notice Patterns in Expressions

Suggested Centers

- Rolling for Fractions (3–5), Stage 2: Multiply a Fraction by a Whole Number (Supporting)
- Five in a Row: Multiplication (3–5), Stage 4: Three Factors (Supporting)
- Rolling for Fractions (3–5), Stage 4: Multiply Fractions (Addressing)
- How Close? (1–5), Stage 7: Multiply Fractions and Whole Numbers to 5 (Supporting)
- Compare (1–5), Stage 4: Divide within 100 (Supporting)

Section B: Fraction Division

Standards Alignments

Building On	4.NBT.B.6
Addressing	5.NF.B.7, 5.NF.B.7.a, 5.NF.B.7.b, 5.NF.B.7.c
Building Towards	5.NF.B.7, 5.NF.B.7.a, 5.NF.B.7.b

Section Learning Goals

- Divide a unit fraction by a whole number using whole-number division concepts.
- Divide a whole number by a unit fraction using whole-number division concepts.

In grade 3, students learned that division can be understood in terms of equal-size groups and can be interpreted in two ways. For example, $8 \div 4$ can mean finding the size of each group if 8 is put into 4 equal groups, or finding how many groups of 4 are in 8.

In this section, students extend this idea to divide a unit fraction by a whole number and divide a whole number by a unit fraction. They interpret $\frac{1}{2} \div 5$ to mean finding the size of one part if $\frac{1}{2}$ is split into 5 equal parts, and $5 \div \frac{1}{2}$ as a way of finding how many $\frac{1}{2}$ s are in 5.



To build this understanding, students reason about situations, diagrams, and expressions that represent division. They look for patterns and assess the reasonableness of the quotients they find.

Students may notice that to find $5 \div \frac{1}{2}$, they can multiply 5 by 2 because there are 2 halves in each of the 5 wholes. It is not essential, however, that students generalize division of fractions at this point, as they will do so in grade 6.

PLC: Lesson 12, Activity 2, Priya's Work

Suggested Centers

- Rolling for Fractions (3–5), Stage 4: Multiply Fractions (Addressing)
- Compare (1–5), Stage 4: Divide within 100 (Supporting)

- How Close? (1–5), Stage 7: Multiply Fractions and Whole Numbers to 5 (Supporting)
- Compare (1–5), Stage 8: Divide Fractions and Whole Numbers (Addressing)
- Rolling for Fractions (3–5), Stage 5: Divide Unit Fractions and Whole Numbers (Addressing)
- How Close? (1–5), Stage 6: Multiply to 3,000 (Supporting)

Section C: Problem Solving with Fractions

Standards Alignments

Addressing 5.NF.B, 5.NF.B.4, 5.NF.B.6, 5.NF.B.7, 5.NF.B.7.b, 5.NF.B.7.c

Section Learning Goals

- Solve problems involving fraction multiplication and division.

In this section, students solve problems involving multiplication and division of fractions. As they reason about situations and interpret tape diagrams, they see that the same situation or diagram can be expressed with multiplication or division.

For example, if $\frac{1}{2}$ gallon of lemonade is shared equally by 5 friends, each friend gets $\frac{1}{2} \div 5$ gallon of lemonade. This also means that each friend gets $\frac{1}{5}$ of the $\frac{1}{2}$ gallon, which can be expressed by $\frac{1}{5} \times \frac{1}{2}$.

Students interpret situations and diagrams in terms of one or both operations, depending on what makes sense in the given context. In this diagram, the shaded part represents both $\frac{1}{2} \div 5$ and $\frac{1}{5} \times \frac{1}{2}$.

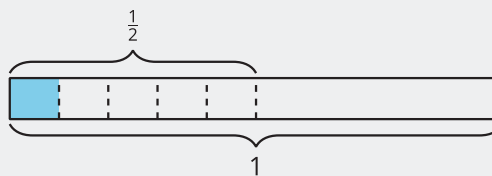

 PLC: Lesson 17, Activity 1, Info Gap: Tiles

Suggested Centers

- Compare (1–5), Stage 8: Divide Fractions and Whole Numbers (Addressing)
- Rolling for Fractions (3–5), Stage 5: Divide Unit Fractions and Whole Numbers (Addressing)
- How Close? (1–5), Stage 6: Multiply to 3,000 (Supporting)

Throughout the Unit

Throughout the unit, the Number Talk routines help students to make sense of the developing concepts in each section. After noticing patterns and making generalizations about multiplying fractions, students multiply fractions using mental math. As the content transitions to division in the second section, students revisit whole-number division and fractions as quotients before dividing with unit fractions. As students apply their knowledge of fraction multiplication and division to solve problems in the final section, the Number Talk routines help to build computation fluency.

Here is a sampling of Number Talk warm-ups in the unit.

lesson 4	lesson 8	lesson 10	lesson 11
$\frac{1}{2} \times \frac{1}{2}$	$\frac{1}{3} \times \frac{3}{5}$	$120 \div 12$	$72 \div 4$
$\frac{1}{3} \times \frac{1}{2}$	$\frac{2}{3} \times \frac{3}{5}$	$120 \div 6$	$36 \div 4$
$\frac{1}{4} \times \frac{1}{2}$	$\frac{5}{3} \times \frac{3}{5}$	$120 \div 3$	$4 \div 4$
$\frac{1}{5} \times \frac{1}{2}$	$\frac{2}{3} \times \frac{13}{5}$	$120 \div 2$	$1 \div 4$

lesson 14	lesson 15	lesson 17	lesson 18
$6 \div 1$	$6 \div 3$	$5 \div \frac{1}{6}$	$3 \times \frac{1}{10}$
$6 \div \frac{1}{2}$	$6 \div \frac{1}{3}$	$5 \times \frac{1}{6}$	$\frac{1}{10} \times 3$
$6 \div \frac{1}{3}$	$\frac{1}{3} \div 6$	$\frac{1}{5} \div 6$	$\frac{1}{10} \div 3$
$6 \div \frac{1}{6}$	$\frac{1}{3} \div 12$	$\frac{1}{5} \times \frac{1}{6}$	$3 \div \frac{1}{10}$

Materials Needed

LESSON	GATHER	COPY
A.1	<ul style="list-style-type: none"> • none 	<ul style="list-style-type: none"> • none
A.2	<ul style="list-style-type: none"> • none 	<ul style="list-style-type: none"> • none
A.3	<ul style="list-style-type: none"> • none 	<ul style="list-style-type: none"> • none
A.4	<ul style="list-style-type: none"> • none 	<ul style="list-style-type: none"> • none
A.5	<ul style="list-style-type: none"> • none 	<ul style="list-style-type: none"> • none
A.6	<ul style="list-style-type: none"> • none 	<ul style="list-style-type: none"> • none
A.7	<ul style="list-style-type: none"> • none 	<ul style="list-style-type: none"> • none
A.8	<ul style="list-style-type: none"> • none 	<ul style="list-style-type: none"> • none
A.9	<ul style="list-style-type: none"> • Colored pencils or crayons • Paper • Rulers 	<ul style="list-style-type: none"> • none
B.10	<ul style="list-style-type: none"> • Tools for creating a visual display 	<ul style="list-style-type: none"> • none
B.11	<ul style="list-style-type: none"> • Tools for creating a visual display 	<ul style="list-style-type: none"> • none
B.12	<ul style="list-style-type: none"> • none 	<ul style="list-style-type: none"> • none
B.13	<ul style="list-style-type: none"> • Construction paper 	<ul style="list-style-type: none"> • none
B.14	<ul style="list-style-type: none"> • none 	<ul style="list-style-type: none"> • none
B.15	<ul style="list-style-type: none"> • Materials from a previous lesson 	<ul style="list-style-type: none"> • Fraction Division Problem Sort (groups of 2)
B.16	<ul style="list-style-type: none"> • none 	<ul style="list-style-type: none"> • none
C.17	<ul style="list-style-type: none"> • none 	<ul style="list-style-type: none"> • Info Gap: Tiles (groups of 2)

Center: Rolling for Fractions (3–5)

Stage 2: Multiply a Fraction by a Whole Number

Lessons

- Grade5.3.A1 (supporting)
- Grade5.3.A2 (supporting)

Stage Narrative

Students roll 3 number cubes to generate a multiplication expression with a whole number and a fraction and compare the value of the expression to 1 in order to determine how many points are earned. Two recording sheets are provided, one where the fraction is a unit fraction and one where it can be any fraction.

Variation:

Students may choose a different target number to compare the value of their expression to.

Stage Description

Each group of 2 needs 3 number cubes.

Standards Alignments

Addressing 4.NF.B.4

Materials to Gather

Number cubes

Materials to Copy

Rolling for Fractions Stage 2 Recording Sheet
(groups of 1)

Stage 4: Multiply Fractions

Lessons

- Grade5.3.A2 (addressing)
- Grade5.3.A3 (addressing)
- Grade5.3.A4 (addressing)
- Grade5.3.A5 (addressing)
- Grade5.3.A6 (addressing)
- Grade5.3.A7 (addressing)
- Grade5.3.A8 (addressing)
- Grade5.3.A9 (addressing)
- Grade5.3.B10 (addressing)
- Grade5.3.B11 (addressing)
- Grade5.3.B12 (addressing)
- Grade5.3.B13 (addressing)

Stage Narrative

Students roll 4 number cubes to generate a multiplication expression involving 2 fractions and compare the value of the expressions. Two recording sheets are provided, one where one fraction is a unit fraction and one with no numerators given.

Standards Alignments

Addressing 5.NF.B.4.a

Materials to Gather

Number cubes

Materials to Copy

Rolling for Fractions Stage 4 Recording Sheet
(groups of 1)

Additional Information

Each group of 2 needs 4 number cubes.

Stage 5: Divide Unit Fractions and Whole Numbers

Lessons

- Grade5.3.B14 (addressing)
- Grade5.3.B15 (addressing)
- Grade5.3.B16 (addressing)
- Grade5.3.C17 (addressing)
- Grade5.3.C18 (addressing)
- Grade5.3.C19 (addressing)
- Grade5.3.C20 (addressing)

Stage Narrative

Students roll 3 number cubes to generate a division expression involving a whole number and a fraction and compare the value of the expressions.

Standards Alignments

Addressing 5.NF.B.7

Materials to Gather

Number cubes

Materials to Copy

Rolling for Fractions Stage 5 Recording Sheet
(groups of 1)

Additional Information

Each group of 2 needs 3 number cubes.

Stages used in Grade 4

Stage 1

Supporting

- Grade4.3.A
- Grade4.4.A

Stage 2

Addressing

- Grade4.3.A
- Grade4.3.B
- Grade4.3.C

Supporting

- Grade4.6.C
- Grade4.7.A

Center: Five in a Row: Multiplication (3–5)

Stage 4: Three Factors

Lessons

- Grade5.3.A1 (supporting)
- Grade5.3.A2 (supporting)
- Grade5.3.A3 (supporting)
- Grade5.3.A4 (supporting)

Stage Narrative

Students multiply using 3 factors of 1–5. Partner A chooses three numbers and places a paper clip on each number. They multiply the numbers and place a counter on the product. Partner B moves one of the paper clips to a different number, multiplies the numbers, and places a counter on the product. Students take turns moving one paper clip, finding the product, and covering it with a counter.

Standards Alignments

Addressing 5.MD.C.5.a

Materials to Gather

Paper clips, Two-color counters

Materials to Copy

Five in a Row Multiplication and Division Stage 4 Gameboard (groups of 2)

Additional Information

Each group of 2 needs 25 two-color counters and 3 paper clips.

Stages used in Grade 4

Stage 1

Supporting

- Grade4.1.A

Stage 2

Addressing

- Grade4.1.A
- Grade4.1.B

Supporting

- Grade4.5.A
- Grade4.6.A
- Grade4.6.B

Stage 3

Addressing

- Grade4.6.B
- Grade4.6.C

Center: How Close? (1–5)

Stage 6: Multiply to 3,000

Lessons

- Grade5.3.C20 (addressing)
- Grade5.3.B15 (supporting)
- Grade5.3.B16 (supporting)
- Grade5.3.C17 (supporting)
- Grade5.3.C18 (supporting)
- Grade5.3.C19 (supporting)
- Grade5.3.C20 (supporting)

Stage Narrative

Before playing, students remove the cards that show 10 and set them aside.

Each student picks 6 cards and chooses 4 of them to create a multiplication expression. Each student multiplies the numbers and the student whose product is closest to 3,000 wins a point for the round. Students pick new cards so that they have 6 cards in their hand and then start the next round.

Variation:

Students can choose a different number as the goal.

Standards Alignments

Addressing 3.OA.B.5

Materials to Gather

Number cards 0–10

Materials to Copy

How Close? Stage 6 Recording Sheet (groups of 1)

Stage 7: Multiply Fractions and Whole Numbers to 5

Lessons

- Grade5.3.A5 (supporting)
- Grade5.3.A6 (supporting)
- Grade5.3.A7 (supporting)
- Grade5.3.A8 (supporting)
- Grade5.3.A9 (supporting)
- Grade5.3.B10 (supporting)
- Grade5.3.B11 (supporting)
- Grade5.3.B12 (supporting)
- Grade5.3.B13 (supporting)

Stage Narrative

Before playing, students remove the cards that show 10 and set them aside.

Each student picks 6 cards and chooses 3 of them to create a multiplication expression with a fraction and a whole number. Each student multiplies their numbers and the student whose product is closest to 5 wins a point for the round. Students pick new cards so that they have 6 cards in their hand and then start the next round.

Variation:

Students can choose a different number as the goal.

Standards Alignments

Addressing 5.NBT.B.7

Materials to Gather

Number cards 0–10

Materials to Copy

How Close? Stage 7 Recording Sheet (groups of 1)

Stages used in Grade 4

Stage 5

Supporting

- Grade4.5.A

Stage 6

Addressing

- Grade4.5.A
- Grade4.5.B

Supporting

- Grade4.2.C

Center: Compare (1–5)

Stage 4: Divide within 100

Lessons

- Grade5.3.A8 (supporting)
- Grade5.3.A9 (supporting)
- Grade5.3.B10 (supporting)
- Grade5.3.B11 (supporting)
- Grade5.3.B12 (supporting)
- Grade5.3.B13 (supporting)

Stage Narrative

Students use cards with division expressions within 100.

This stage of the Compare center is used in grades 3, 4, and 5. When used in grade 3 or 4, remove the cards with two-digit divisors.

Standards Alignments

Addressing 3.OA.C.7

Materials to Copy

Compare Stage 3-8 Directions (groups of 2), Compare Stage 4 Division Cards (groups of 2)

Stage 8: Divide Fractions and Whole Numbers

Lessons

- Grade5.3.B14 (addressing)
- Grade5.3.B15 (addressing)
- Grade5.3.B16 (addressing)
- Grade5.3.C17 (addressing)
- Grade5.3.C18 (addressing)
- Grade5.3.C19 (addressing)

Stage Narrative

Students use cards with expressions with multiplication and division of fractions.

Standards Alignments

Addressing 5.NF.B.4, 5.NF.B.7, 5.OA.A.2

Materials to Copy

Compare Stage 3-8 Directions (groups of 2), Compare Stage 8 Cards (groups of 2)

Stages used in Grade 4

Stage 3

Supporting

- Grade4.2.C
- Grade4.3.C
- Grade4.5.A
- Grade4.5.B
- Grade4.6.B

Stage 4

Supporting

- Grade4.6.C

Stage 5

Addressing

- Grade4.2.C

Supporting

- Grade4.3.A
- Grade4.7.A
- Grade4.7.B
- Grade4.7.C
- Grade4.8.A
- Grade4.8.B

Stage 6

Addressing

- Grade4.3.B
- Grade4.3.C

Stage 7

Addressing

- Grade4.6.D

Supporting

- Grade4.7.A
- Grade4.8.A
- Grade4.8.B

Section A: Fraction Multiplication

Lesson 1: One Piece of One Part

Standards Alignments

Addressing	5.NF.B.4.a
Building Towards	5.NF.B.4, 5.NF.B.4.a

Teacher-facing Learning Goals

- Represent and interpret a unit fraction of a unit fraction in ways that make sense to them.

Student-facing Learning Goals

- Let's solve problems about unit fractions.

Lesson Purpose

The purpose of this lesson is for students to interpret and represent a unit fraction of a unit fraction with diagrams.

In the previous unit, students found the product of a whole number and a fraction or mixed number, using tape diagrams and area diagrams. This unit continues that work to include products of two fractions. The goal of this lesson is for students to investigate fractions of fractional quantities in context. The focus is on interpreting representations in terms of the context (MP2). In later lessons, students will see that the diagrams can be represented by multiplication or division expressions.

In the first activity, students draw and explain their own representation of a situation involving macaroni and cheese. Students' representations may differ so the discussion focuses on how their diagrams represent the situation. The second activity focuses on area diagrams like students worked with at the end of the previous unit. This lesson prepares students to relate diagrams to expressions in the next lesson.

Access for:

Students with Disabilities

- Action and Expression (Activity 1)

English Learners

- MLR2 (Activity 1)

Instructional Routines

5 Practices (Activity 1), Notice and Wonder (Warm-up)

Lesson Timeline

Warm-up	10 min
Activity 1	20 min
Activity 2	15 min
Lesson Synthesis	10 min
Cool-down	5 min

Teacher Reflection Question

Which students had opportunities to share their diagrams and thinking during whole-class discussion? How did you select these students?

Cool-down (to be completed at the end of the lesson)

🕒 5 min

Macaroni and Cheese

Standards Alignments

Addressing 5.NF.B.4.a

Student-facing Task Statement

- A pan of macaroni and cheese is $\frac{1}{2}$ full. Mai eats $\frac{1}{5}$ of the remaining macaroni and cheese in the pan.
 - Draw a diagram to represent the situation.
 - How much of the whole pan did Mai eat? Explain or show your reasoning.

Student Responses

- Sample response:

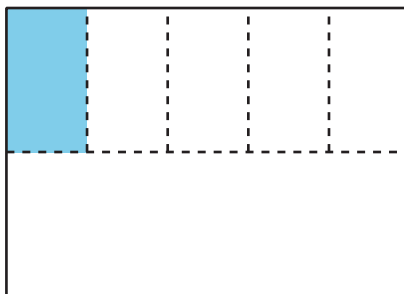

- Mai ate $\frac{1}{10}$ of the whole pan. Students may refer to the diagram they drew.

Begin Lesson

Warm-up

🕒 10 min

Notice and Wonder: Baked Macaroni and Cheese

Standards Alignments

Building Towards 5.NF.B.4.a

The purpose of this warm-up is for students to describe the fraction of macaroni and cheese that is left in the pan. While students may notice and wonder many things about this image, the amount of macaroni and cheese in the pan is the important discussion point.

Instructional Routines

Notice and Wonder

Student-facing Task Statement

What do you notice? What do you wonder?

**Student Responses**

Students may notice:

- The pan isn't full.
- There is a spatula.
- It looks like macaroni and cheese.

Students may wonder:

- Who made the macaroni and cheese?
- How much is left?

Launch

- Groups of 2
- Display the image.
- "What do you notice? What do you wonder?"
- 1 minute: quiet think time

Activity

- "Discuss your thinking with your partner."
- 1 minute: partner discussion
- Share and record responses.

Synthesis

- "The picture shows a pan of macaroni and cheese. What other food is baked in pans like this one?" (lasagna, casseroles, cakes)
- "About how much macaroni and cheese is left in the pan?" (It's less than $\frac{1}{2}$ and more than $\frac{1}{3}$. It looks like it is about $\frac{2}{5}$.)

- Who is going to eat that macaroni and cheese?

Activity 1

🕒 20 min

Of What?

Standards Alignments

Building Towards 5.NF.B.4

The goal of this activity is for students to draw diagrams that represent a unit fraction multiplied by another unit fraction in context. The macaroni and cheese context was introduced in the warm-up to motivate students to draw a diagram to represent the pan. The focus in this activity is on the different diagrams students draw and how they represent the same situation (MP2). Some students may identify that Lin ate $\frac{1}{6}$ of the pan. Invite these students to share their observation at the end of the synthesis when they think about the diagrams in relation to the fraction of the whole pan of macaroni and cheese Lin ate.

🌐 Access for English Learners

MLR2 Collect and Display. Collect the language students use to solve how much of the pan of macaroni Lin ate. Display words and phrases such as: “diagram,” “half,” “fraction,” “divide,” “whole,” “part,” “this much,” “piece.” During the synthesis, invite students to suggest ways to update the display: “What are some other words or phrases we should include?” Invite students to borrow language from the display as needed.

Advances: Conversing, Reading

♿ Access for Students with Disabilities

Action and Expression: Develop Expression and Communication. Provide access to a variety of tools: colored pencils, crayons, highlighters that can be used to differentiate between the initial part and the remaining fractional part.

Supports accessibility for: Conceptual Processing, Visual-Spatial Processing, Organization

Instructional Routines

5 Practices

Student-facing Task Statement

At a family dinner, a pan of macaroni and cheese is $\frac{1}{2}$ full. Lin eats $\frac{1}{3}$ of the remaining macaroni and cheese in the pan.

1. Draw a diagram to represent the situation.
2. Explain or show how you know your diagram represents the situation.

Student Responses

1. Sample responses:

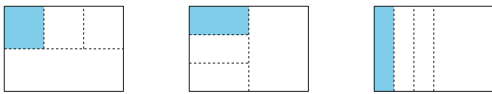

2. I first drew a rectangle to represent the pan of macaroni. Then I cut the rectangle in half since only half of the macaroni was left. Then I cut that half in thirds and shaded one of them. That third of a half pan is what Lin ate.

Launch

- “We are going to solve problems about a pan of macaroni and cheese that was served at a big family dinner. Lin is excited that her aunt made her famous baked macaroni and cheese. Tell your partner a story about a dish that you love to eat for dinner.”
- 1–2 minutes: partner discussion

Activity

- 3–5 minutes: individual work time
- As students work, consider asking:
 - “How does your diagram show $\frac{1}{2}$?”
 - “How does your diagram show $\frac{1}{3}$ of $\frac{1}{2}$?”
 - “How did you decide how to partition the rectangle?”
- Monitor for students who draw different diagrams to show $\frac{1}{3}$ of $\frac{1}{2}$ such as those shown in the student solutions.

Synthesis

- Ask selected students to display their responses side by side for all to see or use the images provided in the student solutions.
- For each diagram ask: “How does the diagram represent $\frac{1}{3}$ of $\frac{1}{2}$ of the pan?” (First, the rectangle or pan is divided in half and then a third of one half is shaded.)
- “How are the diagrams the same?” (They all show the full pan cut in half. Then they show a half cut into 3 equal pieces and one of those pieces is shaded.)
- “How are the diagrams different?” (One diagram cuts the pan in half horizontally and the other two cut it in half vertically. The other cuts into 3 equal pieces are also

sometimes horizontal and sometimes vertical.)

- “How much of the whole pan did Lin eat?” (Students may say $\frac{1}{6}$ or other fractions.)
- Record all responses and revisit this in the lesson synthesis.

Advancing Student Thinking

If students do not draw a diagram that represents the situation, suggest they draw a diagram to show how much of the pan of macaroni and cheese is left. Then ask: “How can you adapt your diagram to show that one third of one half of the pan was eaten?”

Activity 2

🕒 15 min

The Same, but Different

Standards Alignments

Addressing 5.NF.B.4.a

Continuing the macaroni and cheese context from the previous activity, the purpose of this activity is for students to interpret diagrams showing a fraction of a fraction of the pan. Then students address what fraction of the whole pan the shaded piece of the diagram represents. Because the whole pan is not subdivided, students may need to add the extra divisions or think carefully to identify the fraction of the whole pan represented by the diagrams. To identify that the shaded pieces in the two diagrams have equal area students may

- cut out and compare the shaded pieces explicitly
- reason that they are each $\frac{1}{4}$ or $\frac{1}{2}$ of the same amount
- reason that they are each $\frac{1}{8}$ of the whole

Student-facing Task Statement

1. Explain or show how each diagram

Launch

- Groups of 2

represents $\frac{1}{4}$ of $\frac{1}{2}$ of a pan of macaroni and cheese.

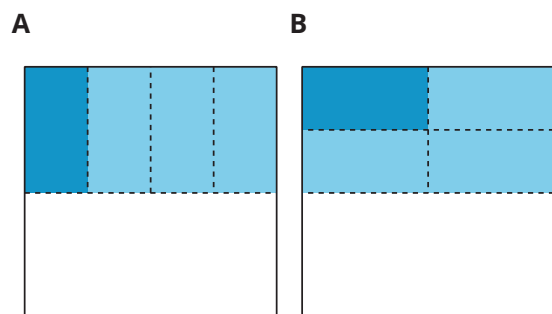

2. Use the diagrams to show that $\frac{1}{4}$ of $\frac{1}{2}$ is $\frac{1}{8}$ of the whole pan.

Student Responses

- Diagram A shows $\frac{1}{2}$ of the pan shaded in and then $\frac{1}{4}$ of the half is shaded darker so that's $\frac{1}{4}$ of $\frac{1}{2}$ that is shaded darker. Diagram B also shows $\frac{1}{2}$ of the pan shaded in and then $\frac{1}{4}$ of the half shaded darker.
- I cut out the pieces and checked that they are the same size.
 - When I divided the whole pan into equal-size parts I saw that each piece is $\frac{1}{8}$ of the pan.

Activity

- 1–2 minutes: quiet think time
- 5–8 minutes: partner discussion
- Monitor for students who:
 - extend the dashed lines in diagram A to determine that $\frac{1}{8}$ of the whole square is darkly shaded
 - partition the rest of the square in diagram B to determine that $\frac{1}{8}$ of the whole square is darkly shaded

Synthesis

- Ask previously selected students to share in the given order.
- “How does each diagram represent $\frac{1}{4}$ of $\frac{1}{2}$?” (They each show $\frac{1}{2}$ shaded in the lighter blue and then $\frac{1}{4}$ of that half is shaded darker.)
- “How do we know the darkly shaded pieces are the same size?” (I cut them out to check. They are both $\frac{1}{4}$ of $\frac{1}{2}$. They both represent $\frac{1}{8}$ of the whole pan.)
- If not already mentioned by students, ask: “How can we figure out how much of the whole pan of macaroni and cheese the dark shaded piece represents?” (We can extend the lines in diagram A and we can partition the rest of the square in diagram B.)
- “ $\frac{1}{4}$ of $\frac{1}{2}$ is equal to how much of the whole pan of macaroni and cheese?” ($\frac{1}{8}$ of the whole pan.)

Advancing Student Thinking

If students do not explain why each diagram represents $\frac{1}{4}$ of $\frac{1}{2}$, suggest they draw their own diagram to represent $\frac{1}{4}$ of $\frac{1}{2}$. Ask: “What is the same about your diagrams and the ones in the tasks? What is different?”

Lesson Synthesis

🕒 10 min

“Today we drew diagrams to represent fractions of fractions. What did you learn about fractions of fractions?” (They are pieces of pieces.)

Consider asking students to respond in their journals.

Refer to the diagrams students drew to show $\frac{1}{3}$ of $\frac{1}{2}$ of a pan of macaroni and cheese.

“How much of the whole pan of macaroni and cheese did Lin eat? How do you know?” ($\frac{1}{6}$. I would need to divide the whole rectangle, not just the one half that was left. Then there would be 6 equal parts and Lin ate one of them.)

Suggested Centers

- Rolling for Fractions (3–5), Stage 2: Multiply a Fraction by a Whole Number (Supporting)
- Five in a Row: Multiplication (3–5), Stage 4: Three Factors (Supporting)

Complete Cool-Down

Response to Student Thinking

Students do not draw a diagram that represents $\frac{1}{2}$ of $\frac{1}{5}$.

Next Day Support

- During activity 1 of the next day's lesson, ask these students to explain where they see each fraction in their diagrams.

Lesson 2: Represent Unit Fraction Multiplication

Standards Alignments

Addressing 5.NF.B.4.a

Teacher-facing Learning Goals

- Represent multiplication of unit fractions with diagrams and expressions

Student-facing Learning Goals

- Let's write expressions to represent multiplication of unit fractions.

Lesson Purpose

The purpose of this lesson is for students to write and evaluate expressions given a diagram that represents the product of two unit fractions.

In the previous lesson, students drew diagrams to represent a unit fraction of another unit fraction in context. The purpose of this lesson is for students to draw diagrams representing products of unit fractions and to examine the relationship between expressions and diagrams in greater depth. Students examine different methods for representing unit fraction products with a diagram and they interpret how a diagram represents a given expression.

This diagram represents both $\frac{1}{4} \times \frac{1}{3}$ and $\frac{1}{3} \times \frac{1}{4}$. In future lessons, this diagram will be used to represent multiplication expressions and equations because of its flexibility.

Student generated diagrams may be different.

In this diagram, we see $\frac{1}{4} \times \frac{1}{3}$. We would need to adapt the diagram to show $\frac{1}{3} \times \frac{1}{4}$ more clearly. We could do this by extending the partition lines all the way across.

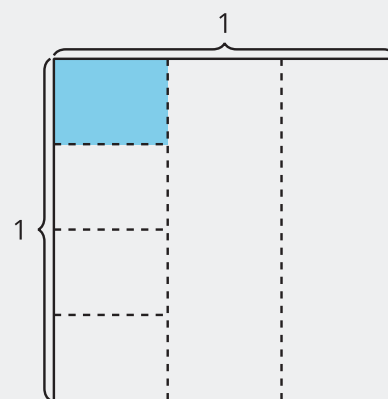
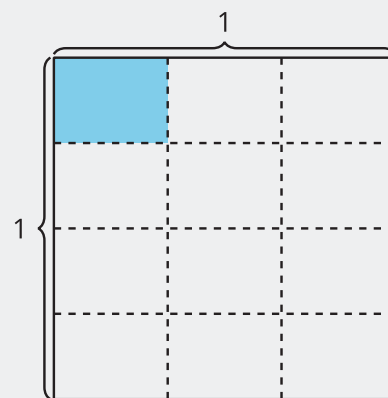

Access for:**🕒 Students with Disabilities**

- Representation (Activity 2)

Instructional Routines

MLR2 Collect and Display (Activity 2), Which One Doesn't Belong? (Warm-up)

Lesson Timeline

Warm-up	10 min
Activity 1	20 min
Activity 2	15 min
Lesson Synthesis	10 min
Cool-down	5 min

Teacher Reflection Question

What did you say, do, or ask during the lesson synthesis that helped students be clear on the learning of the day? How did understanding the cool-down of the lesson before you started teaching today help you synthesize that learning?

Cool-down (to be completed at the end of the lesson)

🕒 5 min

How Much is Shaded?

Standards Alignments

Addressing 5.NF.B.4.a

Student-facing Task Statement

Write a multiplication expression to represent the area of the shaded region.

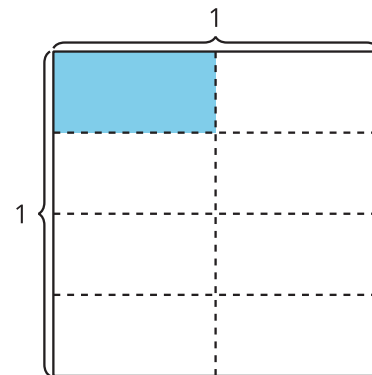

Student Responses

$$\frac{1}{4} \times \frac{1}{2} \text{ or } \frac{1}{2} \times \frac{1}{4}$$

Begin Lesson

Warm-up

🕒 10 min

Which One Doesn't Belong: Diagrams

Standards Alignments

Addressing 5.NF.B.4.a

This warm-up prompts students to carefully analyze and compare different diagrams that represent products of fractions. In making comparisons, students have a reason to use language precisely (MP6). The warm-up also enables the teacher to listen to students as they share their interpretations of the various representations of fraction multiplication, and use their developing vocabulary to describe the characteristics of fractional products.

Instructional Routines

Which One Doesn't Belong?

Student-facing Task Statement

Which one doesn't belong?

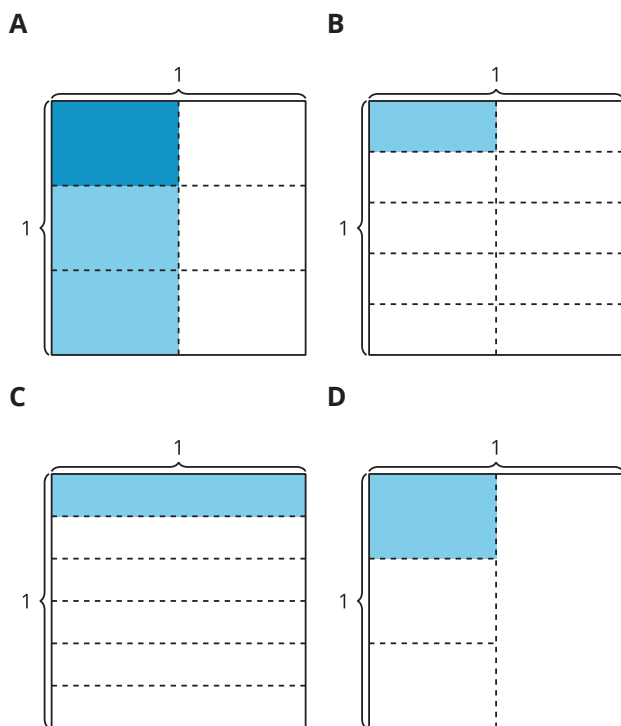

Student Responses

Sample responses:

- A is the only one that doesn't have just one color used to shade.
- B is the only one that doesn't show $\frac{1}{3} \times \frac{1}{2}$.
- C is the only one that doesn't have any vertical cuts. It also does not show a product of fractions in a clear way.
- D is the only one that doesn't show the whole divided into equal pieces.

Launch

- Groups of 2
- Display the image.
- "Pick one that doesn't belong. Be ready to share why it doesn't belong."
- 1 minute: quiet think time

Activity

- "Discuss your thinking with your partner."
- 2-3 minutes: partner discussion
- Share and record responses.

Synthesis

- "How does diagram A represent the expression $\frac{1}{3} \times \frac{1}{2}$?" (There is a half shaded and then a third of the half is shaded darker.)

Activity 1

🕒 20 min

Interpret Diagrams

Standards Alignments

Addressing 5.NF.B.4.a

The purpose of this activity is for students to draw two diagrams that represent a unit fraction of a unit fraction. Students work with the same unit fractions in both diagrams. The directions were intentionally written to encourage students to partition a unit square in different ways. Students initially partition the square into thirds in the first problem and into fourths in the second problem. Students may complete the diagrams in a way that makes sense to them. During the synthesis, students will connect both of the diagrams to the expressions $\frac{1}{4} \times \frac{1}{3}$ and $\frac{1}{3} \times \frac{1}{4}$.

Student-facing Task Statement

1. Show $\frac{1}{3}$ of the square.

Shade $\frac{1}{4}$ of $\frac{1}{3}$ of the square.

How much of the whole square is shaded?

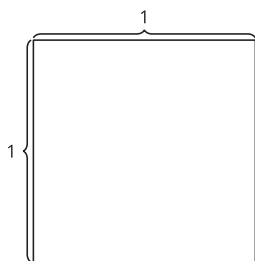

2. Show $\frac{1}{4}$ of the square.

Shade $\frac{1}{3}$ of $\frac{1}{4}$ of the square.

How much of the whole square is shaded?

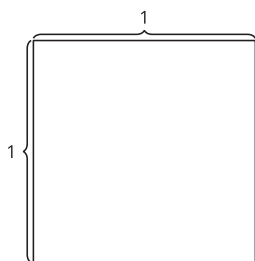

3. How are the diagrams the same and how are they different?

Student Responses

1. Sample responses:

Launch

- Groups of 2

Activity

- 2 minutes: Independent work time
- 10 minutes: partner work time
- Monitor for students who:
 - draw diagrams like those in the student responses
 - recognize that both diagrams have the same amount shaded
 - can explain the different ways they partitioned each diagram

Synthesis

- Ask previously selected students to share their responses in the order given.
- “How are the diagrams the same?” (They both have $\frac{1}{4}$ and $\frac{1}{3}$ in them. They both have $\frac{1}{12}$ of the whole square shaded.)
- “How are the diagrams different?” (In one diagram, I started by showing $\frac{1}{3}$ of the square and then shaded in $\frac{1}{4}$ of $\frac{1}{3}$. In the other diagram, I started by showing $\frac{1}{4}$ of

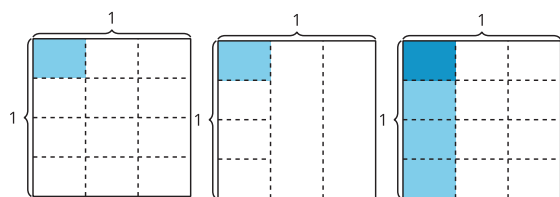

2. Sample responses:

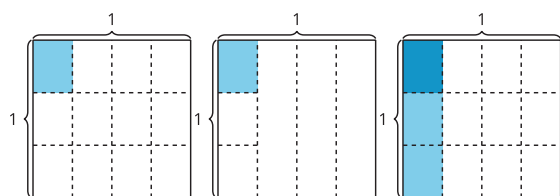

3. They both have $\frac{1}{12}$ shaded. They both show fourths and thirds. To make one of them, I started by drawing thirds, and to make the other one, I started by drawing fourths.

the square and then shaded in $\frac{1}{3}$ of $\frac{1}{4}$.)

- Display: $\frac{1}{12}, \frac{1}{4} \times \frac{1}{3}, \frac{1}{3} \times \frac{1}{4}$
- “How do the diagrams represent these expressions?”
- Adapt diagrams as needed in order to show all three expressions.
- “How do we know that both squares have the same amount shaded?” (They both have $\frac{1}{12}$ shaded.)

Advancing Student Thinking

If students do not identify how much of the whole square is shaded, ask: “How can you adapt your diagram to show how many pieces would be in the whole square?”

Activity 2

🕒 15 min

Write an Expression

Standards Alignments

Addressing 5.NF.B.4.a

The purpose of this activity is for students to deepen their understanding of the relationship between diagrams and multiplication expressions. The expressions here are products of unit fractions. Students start with a diagram and first explain how an expression represents the diagram. Then, they write their own expression representing a different diagram (MP7).

This activity uses *MLR2 Collect and Display*. Advances: Reading, Writing.

Access for Students with Disabilities

Representation: Internalize Comprehension. Synthesis: Invite students to identify which details were most important to represent the shaded piece with a multiplication expression. Display the sentence frame: “The next time I write a multiplication expression to represent the shaded part of a square, I will look for . . .”

Supports accessibility for: Conceptual Processing, Memory

Instructional Routines

MLR2 Collect and Display

Student-facing Task Statement

Priya shaded part of a square.

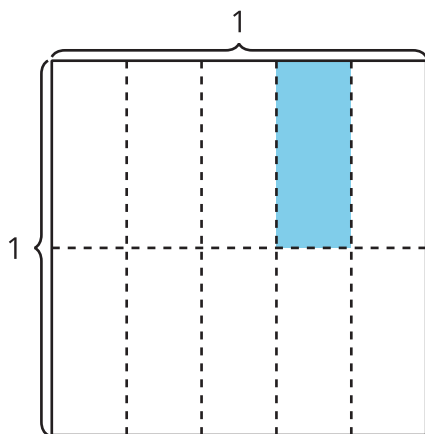

1. Explain or show how the expression $\frac{1}{5} \times \frac{1}{2}$ represents the area of the shaded piece.
2. Explain or show how the expression $\frac{1}{2} \times \frac{1}{5}$ represents the area of the shaded piece.
3. Write a multiplication expression to represent the area of the shaded piece. Be prepared to explain your reasoning.

Launch

- Groups of 2

Activity

- 2 minutes: independent work time
- 5–7 minutes: partner work time

MLR2 Collect and Display

- Circulate, listen for, and collect the language students use to describe where they see how Priya’s diagram represents the expressions. Listen for: columns, rows, fifths, halves, tenths, number of pieces, size of the piece. Record students’ words and phrases on a visual display and update it throughout the lesson.

Synthesis

- “Are there any other words or phrases that are important to include on our display?”
- Ask students to clarify the meaning of a word or phrase.
- As students share responses, update the display, by adding (or replacing) language, diagrams, or annotations.

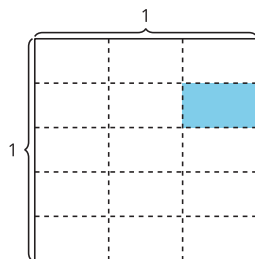

4. How much of the whole square is shaded?

Student Responses

1. The square is divided into 2 halves and $\frac{1}{5}$ of one of the rows is shaded.
2. The square is divided into 5 columns and $\frac{1}{2}$ of one of the columns is shaded.
3. $\frac{1}{3} \times \frac{1}{5}$ or $\frac{1}{5} \times \frac{1}{3}$
4. $\frac{1}{15}$

- Remind students to borrow language from the display as needed.
- Display Priya's diagram and these expressions:
 - $\frac{1}{5} \times \frac{1}{2}$
 - $\frac{1}{2} \times \frac{1}{5}$
- "How does Priya's diagram show each expression?" (The rows show halves and $\frac{1}{5}$ of one of the rows is shaded. The columns show fifths and $\frac{1}{2}$ of one of the columns is shaded.)
- Display the second diagram in the activity.
- "How does the shaded piece in the diagram represent $\frac{1}{5} \times \frac{1}{3}$?" (The square is divided into three columns and each of those columns is divided into 5 rows. The shaded part is $\frac{1}{5}$ of one of the columns.)
- "How does the shaded piece represent $\frac{1}{3} \times \frac{1}{5}$?" (The square is divided into 5 rows and each row is divided into 3 columns. The shaded piece is $\frac{1}{3}$ of one of the rows.)
- "How much of the whole rectangle is shaded?" ($\frac{1}{15}$)

Advancing Student Thinking

If students write an expression that does not represent the second diagram, write a correct expression and ask, "How does the expression represent the diagram?"

Lesson Synthesis

🕒 10 min

"Today we wrote multiplication expressions to represent shaded rectangles. We also wrote fractions to represent the size of the shaded piece."

Display the second image from the second activity.

Display the equations:

$$\frac{1}{3} \times \frac{1}{5} = \frac{1}{15}$$

$$\frac{1}{5} \times \frac{1}{3} = \frac{1}{15}$$

“How do you know these equations are true?” (We can see that the shaded part of the diagram is both $\frac{1}{3} \times \frac{1}{5}$ of the whole and $\frac{1}{5} \times \frac{1}{3}$ of the whole. We can also see $\frac{1}{15}$ because the whole square is divided into 15 equal pieces and one of the equal pieces is shaded.)

Suggested Centers

- Rolling for Fractions (3–5), Stage 4: Multiply Fractions (Addressing)
- Rolling for Fractions (3–5), Stage 2: Multiply a Fraction by a Whole Number (Supporting)
- Five in a Row: Multiplication (3–5), Stage 4: Three Factors (Supporting)

Complete Cool-Down

Response to Student Thinking

Students do not write a correct multiplication expression to represent the area of the shaded region.

Next Day Support

- Before the launch of the next lesson, brainstorm a list of strategies students used to write multiplication expressions that represented the diagram in the cool down.

Lesson 3: Multiply Unit Fractions

Standards Alignments

Addressing 5.NF.B.4.a

Teacher-facing Learning Goals

- Find the product of 2 unit fractions.

Student-facing Learning Goals

- Let's solve equations.

Lesson Purpose

The purpose of this lesson is for students to represent products of unit fractions using diagrams and equations.

In previous lessons students represented products of unit fractions with diagrams and expressions. In this lesson students connect the diagrams and expressions, using the structure of the diagram to calculate the value of the expression. Students use the diagrams to find the value of many expressions and, toward the end of the lesson, they find the value of an expression, representing a product of unit fractions, without being given a diagram.

Access for:

Students with Disabilities

- Engagement (Activity 2)

Instructional Routines

Estimation Exploration (Warm-up), MLR1 Stronger and Clearer Each Time (Activity 2)

Lesson Timeline

Warm-up	10 min
Activity 1	20 min
Activity 2	15 min
Lesson Synthesis	10 min
Cool-down	5 min

Teacher Reflection Question

Some students may be multiplying the numerators and denominators without considering why this strategy works. Why is it important for students to understand how the diagrams represent products of fractions? What questions can you ask to help students connect the diagrams to the procedures they are using?

Cool-down (to be completed at the end of the lesson)

⌚ 5 min

Multiplication Equations

Standards Alignments

Addressing 5.NF.B.4.a

Student-facing Task Statement

- Write a multiplication equation to represent the shaded piece in the figure. Explain or show your reasoning.

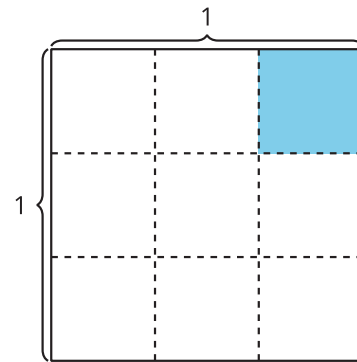

- Complete each equation. Draw a diagram if it helps you.

a. $\frac{1}{5} \times \frac{1}{4} = \underline{\hspace{2cm}}$

b. $\frac{1}{2} \times \frac{1}{6} = \underline{\hspace{2cm}}$

Student Responses

- $\frac{1}{3} \times \frac{1}{3} = \frac{1}{9}$ since there is $\frac{1}{3}$ of a column shaded and that column is $\frac{1}{3}$ of the square. The shaded piece is $\frac{1}{9}$ of the square.
-

a. $\frac{1}{5} \times \frac{1}{4} = \frac{1}{20}$

b. $\frac{1}{2} \times \frac{1}{6} = \frac{1}{12}$

----- **Begin Lesson** -----

Warm-up

 10 min

Estimation Exploration: How Much is Shaded?

Standards Alignments

Addressing 5.NF.B.4.a

The purpose of this Estimation Exploration is for students to estimate the area of a shaded region. In the synthesis, students discuss whether the product is greater or less than the expression $\frac{1}{2} \times \frac{1}{6}$. This allows them to connect the shaded area to their previous work with multiplication expressions (MP7).

Instructional Routines

Estimation Exploration

Student-facing Task Statement

What is the area of the shaded region?

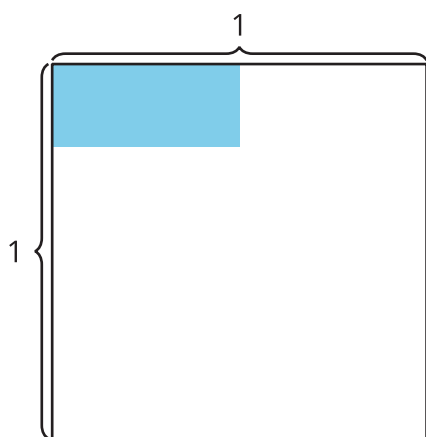

Record an estimate that is:

too low	about right	too high

Student Responses

Sample responses:

- too low: $\frac{1}{16}$ to $\frac{1}{20}$
- about right: $\frac{1}{6}$ to $\frac{1}{10}$

Launch

- Groups of 2
- Display the image.
- “What is an estimate that’s too high? Too low? About right?”
- 1 minute: quiet think time

Activity

- “Discuss your thinking with your partner.”
- 1 minute: partner discussion
- Record responses.

Synthesis

- “Is the area of the shaded region more or less than $\frac{1}{2} \times \frac{1}{6}$? How do you know?” (More. It looks like it is $\frac{1}{2}$ the length and more than $\frac{1}{6}$ the width.)
- “What is the value of $\frac{1}{2} \times \frac{1}{6}$?” ($\frac{1}{12}$)

- too high: $\frac{1}{4}$ to $\frac{1}{2}$

Activity 1

🕒 20 min

Notice Patterns in Expressions

👤 ↔ 👤 PLC Activity

Standards Alignments

Addressing 5.NF.B.4.a

The purpose of this activity is for students to notice structure in a series of diagrams and the expressions that represent them. They investigate how these expressions vary as the number of rows and columns in the diagram change. Students see how the diagram represents the multiplication expression and also how the diagram helps to find the value of the expression (MP7). Through repeated reasoning they also begin to see how to find the value of a product of any two unit fractions (MP8).

Student-facing Task Statement

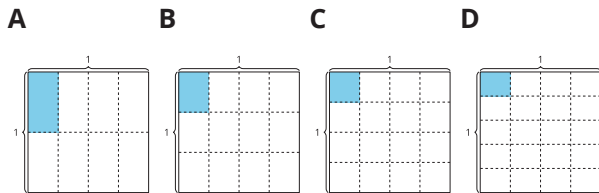

1. Choose one of the diagrams and write a multiplication expression to represent the shaded region. How much of the whole square is shaded? Explain or show your thinking.
2. If the pattern continues, draw what you think the next diagram will look like. Be prepared to explain your thinking.

Launch

- Groups of 2
- Display the images from the task.
- “What is different about these diagrams?” (The number of rows increases by 1. The blue shaded piece gets smaller.)
- “What is the same?” (The size of the big square. There are always 4 columns. Only one piece is shaded.)
- 1 minute: quiet think time
- Share and record responses.

Activity

- 1–2 minutes: independent work time to complete the first problem
- 1–2 minutes: partner discussion
- “Now, complete the rest of the problems with your partner.”

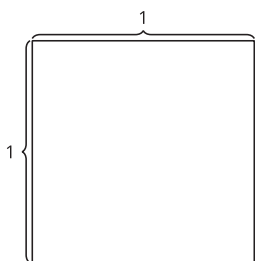

Student Responses

1. Expressions to represent diagrams: $\frac{1}{2} \times \frac{1}{4}$
 or $\frac{1}{4} \times \frac{1}{2}$, $\frac{1}{3} \times \frac{1}{4}$ or $\frac{1}{4} \times \frac{1}{3}$, $\frac{1}{4} \times \frac{1}{4}$, $\frac{1}{5} \times \frac{1}{4}$ or
 $\frac{1}{4} \times \frac{1}{5}$. Amount of whole square that is
 shaded: $\frac{1}{8}$, $\frac{1}{12}$, $\frac{1}{16}$, $\frac{1}{20}$.

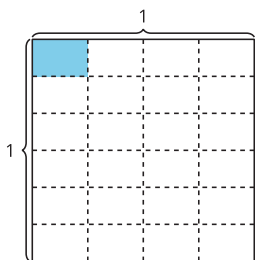

2.

- 5 minutes: partner work time
- Monitor for students who:
 - choose different diagrams to represent with multiplication expressions
 - represent the same diagram with different multiplication expression, for example, $\frac{1}{2} \times \frac{1}{4}$ and $\frac{1}{4} \times \frac{1}{2}$

Synthesis

- Display the diagrams from the student workbook.
- Select previously identified students to share.
- As students explain where they see the multiplication expression in each diagram, record the expressions under the diagram for all to see.
- Refer to the diagram that shows $\frac{1}{2} \times \frac{1}{4}$ or $\frac{1}{4} \times \frac{1}{2}$.
- Display both expressions.
- “How does this diagram represent both of these expressions?” (It shows one half of one fourth shaded in and it also shows one fourth of one half shaded in.)
- Represent student explanation on the diagrams.
- “Why is the area of the shaded region getting smaller in each diagram?” (Because we are shading a smaller piece of $\frac{1}{4}$ each time.)
- Display:

$$\frac{1}{2} \times \frac{1}{4} = \frac{1}{2 \times 4} = \frac{1}{8}$$

$$\frac{1}{3} \times \frac{1}{4} = \frac{1}{3 \times 4} = \frac{1}{12}$$

$$\frac{1}{4} \times \frac{1}{4} = \frac{1}{4 \times 4} = \frac{1}{16}$$

$$\frac{1}{5} \times \frac{1}{4} = \frac{1}{5 \times 4} = \frac{1}{20}$$
- “These equations represent the diagrams. What patterns do you notice?” (They all

have $\frac{1}{4}$ in them. The denominators in the first fractions go 2, 3, 4, 5. The denominators in the middle fractions are multiplication expressions, the denominators in the middle are all multiplied by 4, the denominator in the fraction that shows the value of the shaded piece goes up by 4 each time.)

- “How do the diagrams represent $\frac{1}{2 \times 4}$, $\frac{1}{3 \times 4}$, $\frac{1}{4 \times 4}$, $\frac{1}{5 \times 4}$?” (The numerator tells us that there is 1 piece shaded and the denominator tells us the size of the piece. The denominator also tells us the rows and columns that the whole is divided into.)

Advancing Student Thinking

If students do not write correct expressions to represent the diagrams, write the correct expressions and ask, “How do the expressions represent the area of the shaded piece of the diagram?”

Activity 2

🕒 15 min

Write a Multiplication Equation

Standards Alignments

Addressing 5.NF.B.4.a

The purpose of this activity is for students to use the structure of diagrams to calculate products of unit fractions. They also represent their work using an equation. As students become more familiar with this structure they may not need diagrams as a scaffold to find these products. Drawing their own diagrams, however, will also reinforce student understanding of how to calculate products of unit fractions.

This activity uses *MLR1 Stronger and Clearer Each Time*. Advances: Reading, Writing.

🗎 Access for Students with Disabilities

Engagement: Provide Access by Recruiting Interest. Invite students to share a connection between the diagram and something in their own lives that represent the fractional values.

Supports accessibility for: Attention, Conceptual Processing

Instructional Routines

MLR1 Stronger and Clearer Each Time

Student-facing Task Statement

- Write a multiplication equation to represent the area of the shaded piece.

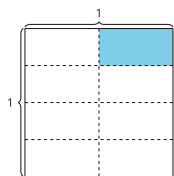

- Explain how the diagram represents the equation $\frac{1}{5} \times \frac{1}{3} = \frac{1}{15}$.

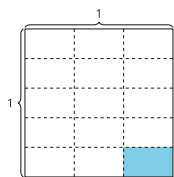

- Find the value that makes each equation true. Use a diagram, if it is helpful.

a. $\frac{1}{2} \times \frac{1}{6} = ?$

b. $\frac{1}{4} \times \frac{1}{6} = ?$

Student Responses

Sample responses:

1. $\frac{1}{4} \times \frac{1}{2} = \frac{1}{8}$, $\frac{1}{2} \times \frac{1}{4} = \frac{1}{8}$

- The square is divided into three equal pieces

Launch

- Groups of 2

Activity

- 3-5 minutes: independent work time
- 1-2 minutes: partner discussion

Synthesis

- Display: $\frac{1}{2} \times \frac{1}{4} = \frac{1}{(2 \times 4)} = \frac{1}{8}$ and the corresponding diagram.
- “How does this equation represent the diagram?” (One fourth of one half is shaded which is the same as 1 piece of the whole square that is divided into 2 columns and 4 rows so one eighth of the whole square is shaded.)

MLR1 Stronger and Clearer Each Time

- “Share your explanation about how the last diagram represents $\frac{1}{5} \times \frac{1}{3} = \frac{1}{15}$ with your partner. Take turns being the speaker and the listener. If you are the speaker, share your ideas and writing so far. If you are the listener, ask questions and give feedback to help your partner improve their work.”
- 3-5 minutes: structured partner discussion
- Repeat with 2-3 different partners.

and each of the thirds is divided into 5 equal pieces so $\frac{1}{5}$ of $\frac{1}{3}$ is shaded in which is the same as $\frac{1}{15}$ of the whole square.

3.

- a. $\frac{1}{12}$
b. $\frac{1}{24}$

- If needed, display question starters and prompts for feedback.
 - “Can you give an example to help show . . . ?”
 - “Can you use the word ____ in your explanation?”
 - “The part that I understood best was”
- “Revise your initial draft based on the feedback you got from your partners.”
- 2–3 minutes: independent work time.

Advancing Student Thinking

If students do not refer to the rows and columns when they explain how the diagram represents the equation $\frac{1}{5} \times \frac{1}{3} = \frac{1}{15}$, ask “How are the rows and columns in the diagram represented in the equation?”

Lesson Synthesis

🕒 10 min

“Today we represented products of unit fractions with diagrams and with equations.”

“How is multiplying unit fractions the same as multiplying whole numbers? How is it different?” (We use the same multiplication facts to find the value of expressions, but the value is less than one because we are multiplying the denominators. We use diagrams that show rows and columns to multiply whole numbers and unit fractions, but the rows and columns show fractions of 1 instead of more than 1.)

Consider asking:

“In future lessons, we are going to multiply fractions that have a numerator greater than 1. What do you wonder about that?” (Will we use the same diagrams? Will it work the same way as unit fractions?)

Suggested Centers

- Rolling for Fractions (3–5), Stage 4: Multiply Fractions (Addressing)
- Five in a Row: Multiplication (3–5), Stage 4: Three Factors (Supporting)

----- Complete Cool-Down -----

Response to Student Thinking

Students don't write equations that represent the diagrams.

Next Day Support

- During the synthesis of the warm-up in the next lesson, draw diagrams to represent the equations and ask students to explain how the diagrams represent the equations.

Lesson 4: Situations about Multiplying Fractions

Standards Alignments

Addressing	5.NF.B.4.a
Building Towards	5.NF.B.4.b

Teacher-facing Learning Goals

- Represent and solve problems involving multiplication of a unit fraction and a non-unit fraction.

Student-facing Learning Goals

- Let's solve problems about multiplying unit fractions.

Lesson Purpose

The purpose of this lesson is for students to represent the product of a unit fraction and a non-unit fraction with a diagram.

In previous lessons, students used a diagram to visualize quantities, write a multiplication expression, and find the value of the product. This lesson uses the context of a park to encourage students to use an area diagram. After using the diagram to create an expression in the first activity, students work in the other direction in the second activity, finding which part of the park is represented by different expressions. Throughout the lesson, students observe that the methods that helped them find products of unit fractions also work when one of those fractions is not a unit fraction.

Because these problems are in context, the area diagrams do not have the side lengths labeled. This means that students are finding the fraction of the park, rather than the area of a given section. Although this difference is small, it is helpful for teachers to be consistent about the difference in what the diagram represents when it does not have labeled side lengths.

Access for:

Students with Disabilities

- Action and Expression (Activity 2)

English Learners

- MLR8 (Activity 1)

Instructional Routines

Number Talk (Warm-up)

Lesson Timeline

Warm-up	10 min
Activity 1	20 min
Activity 2	15 min
Lesson Synthesis	10 min
Cool-down	5 min

Teacher Reflection Question

If you were to teach this lesson over again, what activity would you redo? How would your proposed changes support student learning?

Cool-down (to be completed at the end of the lesson)

🕒 5 min

Area of the Park

Standards Alignments

Addressing 5.NF.B.4.a

Student-facing Task Statement

- Here is a diagram for a park.

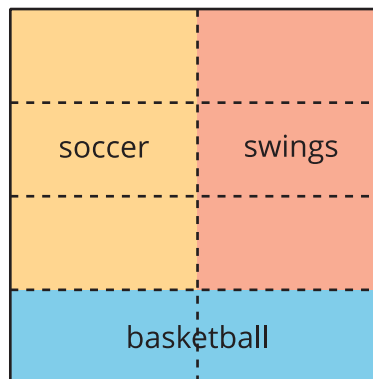

- Write a multiplication expression to represent the fraction of the park that is for soccer.
- How much of the whole park will be used for soccer?

Student Responses

- $\frac{3}{4} \times \frac{1}{2}$ or $\frac{1}{2} \times \frac{3}{4}$

b. $\frac{3}{8}$

----- Begin Lesson -----

Warm-up

🕒 10 min

Number Talk: More Halving

Standards Alignments

Addressing 5.NF.B.4.a

The purpose of this Number Talk is for students to demonstrate strategies and understandings they have for multiplying unit fractions. These understandings help students develop fluency and will be helpful later in this lesson when students make sense of a unit fraction multiplied by a non-unit fraction.

Instructional Routines

Number Talk

Student-facing Task Statement

Find the value each expression mentally.

- $\frac{1}{2} \times \frac{1}{2}$
- $\frac{1}{3} \times \frac{1}{2}$
- $\frac{1}{4} \times \frac{1}{2}$
- $\frac{1}{5} \times \frac{1}{2}$

Student Responses

- $\frac{1}{4}$. Half of a half is one fourth.
- $\frac{1}{6}$. I pictured a diagram that showed $\frac{1}{2}$ cut into 3 equal pieces.

Launch

- Display one expression.
- “Give me a signal when you have an answer and can explain how you got it.”
- 1 minute: quiet think time

Activity

- Record answers and strategy.
- Keep expressions and work displayed.
- Repeat with each expression.

Synthesis

- “What patterns do you notice?” (The

- $\frac{1}{8}$. I multiplied the denominators.
- $\frac{1}{10}$. I doubled the 5 in the denominator because the pieces will be half the size.

numerators are all 1. The denominators are all even numbers. The fractions are getting smaller. Each time, we find a smaller fraction of $\frac{1}{2}$.)

Activity 1

🕒 20 min

The Park

Standards Alignments

Addressing 5.NF.B.4.a

The purpose of this activity is for students to draw a diagram representing the product of a unit fraction and a non-unit fraction. Then students use the diagram to represent the product with an expression and find its value. Students may draw many different diagrams that represent the situation. The context of sports fields was chosen to encourage students to divide the square in thirds, vertically or horizontally and, subsequently, to divide the two thirds that represents the sports in half, horizontally or vertically, to represent the part of the sports section that will be used for soccer fields. The activity synthesis focuses on the expressions and equations that represent the area for the soccer fields. Students reason abstractly and quantitatively throughout as they relate their diagram and the expression representing it to the park (MP2).

🌐 Access for English Learners

MLR8 Discussion Supports. Synthesis: At the appropriate time, give groups 2–3 minutes to plan what they will say when they present to the class. “Practice what you will say when you share your drawing with the class. Talk about what is important to say, and decide who will share each part.”
Advances: Speaking, Conversing, Representing

Student-facing Task Statement

A city is designing a park on a rectangular piece of land. $\frac{2}{3}$ of the park will be used for different sports. $\frac{1}{2}$ of the land set aside for sports will be soccer fields.

1. Draw a diagram of the situation.

Launch

- Groups of 2
- “What kinds of things do you see and do in the park?”
 - play frisbee or other games
 - watch the ducks
 - use the swings

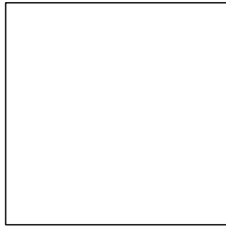

- Write a multiplication expression to represent the fraction of the park that will be soccer fields.
- What fraction of the whole park will be soccer fields? Explain or show your reasoning.

Student Responses

- Sample response:

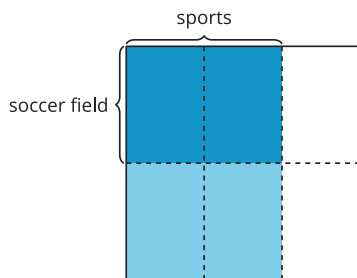

- $\frac{1}{2} \times \frac{2}{3}$
- $\frac{2}{6}$ of the park is used for soccer fields. First I shaded $\frac{2}{3}$ of the square for the sports and then I shaded $\frac{1}{2}$ of that darker for the soccer fields.

Advancing Student Thinking

If students do not draw a diagram that represents $\frac{1}{2} \times \frac{2}{3}$, suggest they draw a diagram to represent the $\frac{2}{3}$ of the park that will be used for different sports. Ask: "How can you adapt your diagram to show that $\frac{1}{2}$ of the section used for sports will be soccer fields?"

- have a picnic
- play with my friends
- 1-2 minutes: independent think time
- 1-2 minutes: partner discussion

Activity

- 5 minutes: partner work time
- Monitor for students who label the diagram to show the different parts of the park.

Synthesis

- Invite students to share their drawings of the soccer fields.
- Display the image from the student solution or use a student-generated image.
- "How does the diagram represent $\frac{2}{3}$?" (There are two vertical slices of the park on the left that are $\frac{2}{3}$ of the park.)
- Display expression: $\frac{1}{2} \times \frac{2}{3}$
- "How does the diagram represent $\frac{1}{2} \times \frac{2}{3}$?" (The top half of the left $\frac{2}{3}$ of the square is shaded darkly.)
- "How does the diagram represent how much of the whole park will be used for soccer fields, which is also the value of $\frac{1}{2} \times \frac{2}{3}$?" (It shows 2 pieces that are each $\frac{1}{6}$ of the whole.)

Activity 2

🕒 15 min

A Different Park

Standards Alignments

Addressing 5.NF.B.4.a

Building Towards 5.NF.B.4.b

The purpose of this activity is for students to relate expressions to a diagram in a situation where they represent the product of a unit fraction and a non-unit fraction. Students work with a diagram that represents a different park. Students write expressions, trade with a partner, and interpret their partner's expressions and match them to a diagram. As students work together, listen for how they explain why the expressions represent the corresponding areas. While the activity focuses on relating expressions and parts of the diagram, in the synthesis students find the value of products and analyze equations in terms of the park (MP2). As students discuss and justify their decisions while looking through each others' work, they share mathematical claims and the thinking behind them (MP3).

🕒 Access for Students with Disabilities

Action and Expression: Internalize Executive Functions. Check for understanding by inviting students to rephrase directions in their own words.

Supports accessibility for: Memory, Organization

Student-facing Task Statement

Here is a diagram for a different park that Elena drew.

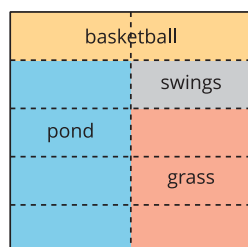

1. Which part of the park can be represented

Launch

- Groups of 2

Activity

- 5–6 minutes: independent think time
- 2–3 minutes: partner work time
- Monitor for students who:
 - can explain why $\frac{1}{5} \times \frac{1}{2}$ represents the part of the park for the swings.
 - can explain why $\frac{3}{5} \times \frac{1}{2}$ represents the part of the park for the grass.

with the expression $\frac{3}{5} \times \frac{1}{2}$? Explain or show your reasoning.

- Pick one of the other parts of the park and write a multiplication expression for the fraction of the park it represents.
- Trade expressions with your partner and figure out which part of the park their expression represents. Be prepared to explain your reasoning.

Student Responses

- The grass, because it takes up $\frac{3}{5}$ of half of the park.
- Sample responses:
 - Basketball: $\frac{1}{5} \times 1$
 - Pond: $\frac{4}{5} \times \frac{1}{2}$
 - Swings: $\frac{1}{5} \times \frac{1}{2}$
- Sample response: My partner wrote $\frac{4}{5} \times \frac{1}{2}$ and that expression represents the part of the park for the pond.

- write $\frac{4}{5} \times \frac{1}{2}$ to represents the part of the park for the pond.

Synthesis

- Ask previously selected students to share their thinking.
- Display: $\frac{1}{5} \times \frac{1}{2} = \frac{1}{10}$
- “What part of the diagram does this equation represent?” (It represents the section of the park that is swings. We can see that the swings take up $\frac{1}{5}$ of $\frac{1}{2}$ of the park.)
- Display: $\frac{3}{5} \times \frac{1}{2} = \frac{3}{10}$
- “What part of the diagram does this equation represent?” (It represents the section of the park for grass, which is $\frac{3}{5}$ of $\frac{1}{2}$ of the park and it is also $\frac{3}{10}$ of the whole park.)
- Display: $\frac{4}{5} \times \frac{1}{2} = \frac{4}{10}$
- “What part of the diagram does this equation represent?” (It represents the section of the park for the pond, which is $\frac{4}{5}$ of $\frac{1}{2}$ of the park and it is also $\frac{4}{10}$ of the whole park.)

Advancing Student Thinking

If students do not identify which section is $\frac{3}{5}$ of $\frac{1}{2}$ of the park, suggest they draw a separate diagram to represent each section. Ask: “How would you describe this section in relation to the whole park? How can you represent what you described with a multiplication expression?”

Lesson Synthesis

🕒 10 min

“Today we represented multiplication of a unit fraction and a non-unit fraction with diagrams and expressions.”

Display the park diagram from the last activity. Display equations:

$$\frac{1}{5} \times \frac{1}{2} = \frac{1}{10}$$

$$\frac{2}{2} \times \frac{1}{5} = \frac{2}{10}$$

$$\frac{3}{5} \times \frac{1}{2} = \frac{3}{10}$$

$$\frac{4}{5} \times \frac{1}{2} = \frac{4}{10}$$

“Describe to your partner how each equation represents the diagram of the park.”

“What patterns do you notice in the equations?” (Each part of the park is a certain amount of tenths. If we multiply the numerators, we get the numerator in the product. If we multiply the denominators, we get the denominator in the product.)

Suggested Centers

- Rolling for Fractions (3–5), Stage 4: Multiply Fractions (Addressing)
- Five in a Row: Multiplication (3–5), Stage 4: Three Factors (Supporting)

Complete Cool-Down

Response to Student Thinking

Students do not write the correct multiplication expression to represent the soccer fields or identify the amount the whole park that is soccer fields.

Next Day Support

- During the synthesis of the warm-up in the next lesson, draw rows and columns on the diagram to represent the expression $\frac{3}{5} \times \frac{1}{2}$. Ask students to explain how the rows and columns help them identify the approximate shaded area.

Lesson 5: Multiply a Unit Fraction by a Non-unit Fraction

Standards Alignments

Addressing 5.NF.B.4.b

Teacher-facing Learning Goals

- Find the product of a unit fraction and a non-unit fraction.

Student-facing Learning Goals

- Let's multiply a unit fraction and a non-unit fraction.

Lesson Purpose

The purpose of this lesson is for students to use diagrams and expressions to calculate the product of a unit fraction and a non-unit fraction.

While the previous lesson used a context to help visualize fractions and their product, in this lesson the fractions are more complex and there is no context so students can focus on how the diagrams and expressions relate to the value of the product. In this lesson students also begin to work with side lengths that are fractions greater than 1. Students also practice estimating areas of rectangles where the side lengths are not shown.

Access for:

Students with Disabilities

- Action and Expression (Activity 2)

English Learners

- MLR8 (Activity 1)

Instructional Routines

Estimation Exploration (Warm-up)

Lesson Timeline

Warm-up	10 min
Activity 1	15 min
Activity 2	20 min

Teacher Reflection Question

How did the work of the previous lessons lay the foundation for students to be successful in Activity 1 of this lesson?

Lesson Synthesis	10 min
Cool-down	5 min

Cool-down (to be completed at the end of the lesson)

⌚ 5 min

Write an Equation

Standards Alignments

Addressing 5.NF.B.4.b

Student-facing Task Statement

Find the value of $\frac{1}{3} \times \frac{4}{5}$. Explain or show your reasoning. Use the diagram if it is helpful.

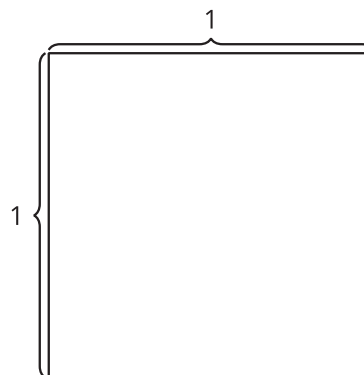

Student Responses

$\frac{1}{3} \times \frac{4}{5} = \frac{4}{15}$. Sample response: There are 4 shaded pieces and each is $\frac{1}{15}$ of the whole.

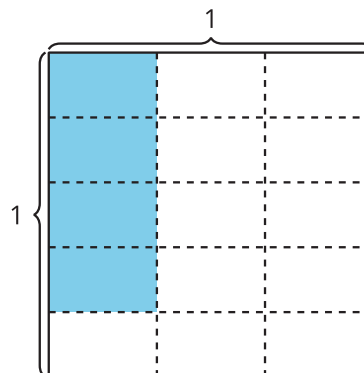

Begin Lesson

Warm-up

🕒 10 min

Estimation Exploration: Shaded Rectangle

Standards Alignments

Addressing 5.NF.B.4.b

The purpose of this Estimation Exploration is for students to estimate the area of a shaded region. In a previous Estimation Exploration, students looked at a shaded region where the length was represented by a unit fraction and the width could be estimated with a unit fraction. For the diagram presented here, the length is a unit fraction but the width can not be since it is greater than $\frac{1}{2}$. This prepares students for the work of this lesson which is to consider products of a unit fraction and a non-unit fraction.

Instructional Routines

Estimation Exploration

Student-facing Task Statement

What is the area of the shaded region?

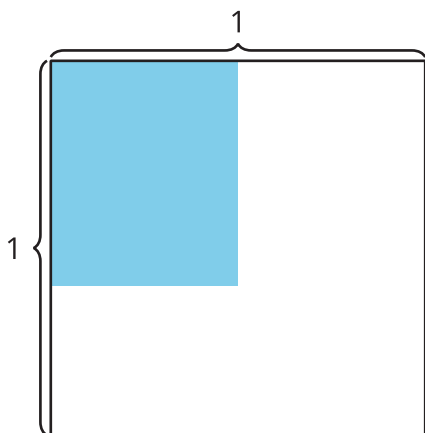

Record an estimate that is:

too low	about right	too high

Launch

- Groups of 2
- Display the image.
- “What is an estimate that’s too high? Too low? About right?”
- 1 minute: quiet think time

Activity

- “Discuss your thinking with your partner.”
- 1 minute: partner discussion
- Record responses.

Synthesis

- “Is the area of the shaded region more or less than $\frac{1}{4}$ square unit? How do you know?” (It’s more because $\frac{1}{2}$ of $\frac{1}{2}$ is $\frac{1}{4}$, and more than that is shaded.)

Student Responses

too low	about right	too high
$\frac{1}{8}$ to $\frac{1}{4}$	$\frac{3}{10}$ to $\frac{4}{10}$	$\frac{1}{2}$

Activity 1

🕒 15 min

Write Equations

Standards Alignments

Addressing 5.NF.B.4.b

The purpose of this activity is for students to write expressions for and find the area of shaded regions whose side lengths are a unit fraction and a non-unit fraction. Students look at a series of diagrams with an increasingly large shaded region so they can look for and make use of structure (MP7).

It is important to relate the work here to what students have already learned about the product of a unit fraction and a unit fraction and this is the goal of the synthesis. For example, students have seen that $\frac{1}{5} \times \frac{1}{3} = \frac{1}{15}$. Since $\frac{6}{5}$ is $6 \frac{1}{5}$ s, the product $\frac{6}{5} \times \frac{1}{3}$ will be $6 \frac{1}{15}$ s or $\frac{6}{15}$.

🌐 Access for English Learners

MLR8 Discussion Supports. Prior to solving the problems, invite students to make sense of the situations and take turns sharing their understanding with their partner. Listen for and clarify any questions about the context.

Advances: Listening, Conversing

Student-facing Task Statement

- Write a multiplication expression that represents the shaded region in each diagram.

A

B

C

Launch

- Groups of 2
- Display image A from the student workbook.
- “What is a multiplication expression that represents the shaded region?” ($\frac{2}{5} \times \frac{1}{3}$, $2 \times \frac{1}{15}$)

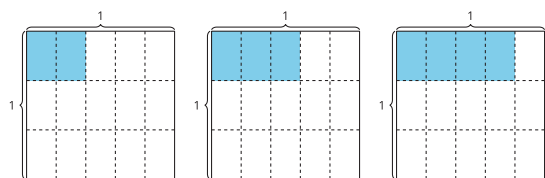

2. What patterns do you notice in the multiplication expressions?
3. Han wrote this equation to represent the area of the shaded region. Explain how the diagram represents the equation.

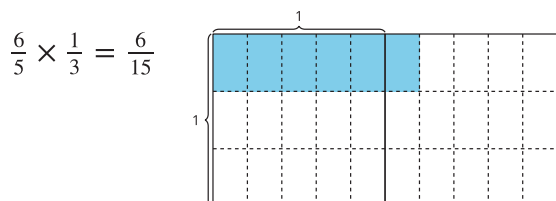

Student Responses

1. Sample solution:
 - $\frac{2}{5} \times \frac{1}{3}$ or $2 \times \frac{1}{15}$
 - $\frac{3}{5} \times \frac{1}{3}$ or $3 \times \frac{1}{5} \times \frac{1}{3}$ or $3 \times \frac{1}{15}$
 - $\frac{4}{5} \times \frac{1}{3}$ or $4 \times \frac{1}{5} \times \frac{1}{3}$ or $4 \times \frac{1}{15}$
2. Sample responses: In each diagram, there is an additional shaded piece whose size is $\frac{1}{15}$. All of the expressions have $\frac{1}{3}$ in them.
3. Sample responses: The area of the shaded region is $\frac{6}{5}$ of $\frac{1}{3}$ of the whole and it is also $\frac{6}{15}$ of the whole.

Advancing Student Thinking

If students write mathematically correct multiplication expressions that do not represent the product of a unit fraction and a non-unit fraction, write this type of multiplication expression that

- “How does the diagram represent your expression?” (There is $\frac{2}{5}$ of the first row shaded and that row is $\frac{1}{3}$ of the square. There are 2 shaded pieces and each is $\frac{1}{15}$ of the whole square.)

Activity

- 3–5 minutes: independent work time
- 3–5 minutes: partner discussion
- Monitor for students who:
 - notice that the product of the numerators represents how many pieces of the square are shaded.
 - notice that the product of the denominators represents the number of pieces in the whole square.

Synthesis

- Ask previously selected students to share the patterns they noticed in the table.
- Display the expression from the last problem: $\frac{6}{5} \times \frac{1}{3} = \frac{6}{15}$.
- “How does the diagram show $\frac{1}{3}$?” (The first row of pieces in a square is $\frac{1}{3}$ of the square.)
- “How does the diagram show $\frac{6}{5}$?” (There are 6 pieces shaded and each one is $\frac{1}{5}$ of the row.)
- “How does the diagram show $\frac{6}{5} \times \frac{1}{3}$?” (There is $\frac{6}{5}$ of a row shaded and that row is $\frac{1}{3}$ of a square unit.)

represents the diagram and ask “How does this expression represent the area of the shaded region in the diagram?”

Activity 2

🕒 20 min

Estimate With Expressions

Standards Alignments

Addressing 5.NF.B.4.b

The purpose of this activity is for students to write multiplication expressions to estimate the area of a shaded region. This builds on the warm-up and the activity launches by asking students to write an expression for the shaded region in the image they considered in the warm-up.

This work in this activity combines the skill of estimation with an understanding that the area of a rectangle relates to its length and width. So far, students have only calculated these areas as products of fractions when at least one side length is a unit fraction. Students may write products of two non-unit fractions. While they have not yet learned how to calculate these products and relate them to areas, these answers are valid when the estimates are reasonable and students will learn in the next lesson how to find the value of these expressions.

🕒 Access for Students with Disabilities

Action and Expression: Internalize Executive Functions. Synthesis: Invite students to plan a strategy, including the tools they will use, for estimating the area of the shaded rectangle. If time allows, invite students to share their plan with a partner before they begin.

Supports accessibility for: Conceptual Processing, Language

Student-facing Task Statement

Write a multiplication expression that might represent the area of the shaded region. Be prepared to explain your reasoning.

1.

Launch

- Groups of 2
- Display the image from the warm-up: “What multiplication expression might represent the area of the shaded region?”
($\frac{2}{3} \times \frac{1}{2}$, $\frac{3}{5} \times \frac{1}{2}$)
- “Why do those expressions make sense?”

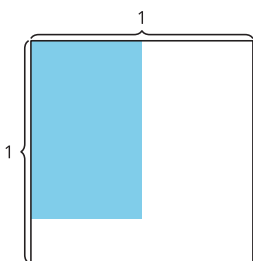

2.

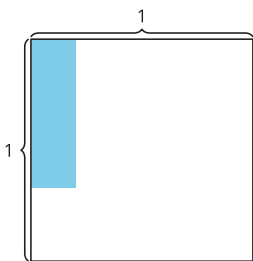

3.

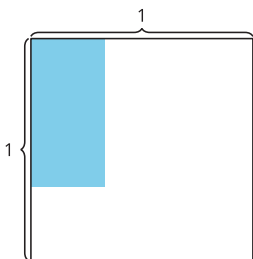

4.

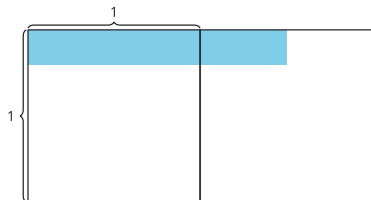

Student Responses

Sample responses:

1. $\frac{3}{4} \times \frac{1}{2}$, $\frac{4}{5} \times \frac{1}{2}$

2. $\frac{2}{3} \times \frac{1}{4}$, $\frac{2}{3} \times \frac{1}{5}$

(We can see that the shaded region is a fraction of $\frac{1}{2}$. It is more than $\frac{1}{2} \times \frac{1}{2}$.)

- “We are going to look at more diagrams and write multiplication expressions that might represent the area of the shaded regions in each one.”

Activity

- 3–5 minutes: independent work time
- 3–5 minutes: partner discussion
- Monitor for students who:
 - use a unit fraction to help them determine reasonable expressions.
 - reason about the size of the shaded region before writing an expression.
 - draw lines to partition the squares.

Synthesis

- Ask previously selected students to share their solutions.
- Display the first diagram.
- “How does thinking about $\frac{1}{2}$ help us estimate the area of the shaded region?” (We know the area is less than $\frac{1}{2}$ because only part of $\frac{1}{2}$ is shaded.)
- “About what fraction of $\frac{1}{2}$ is shaded?” (More than $\frac{1}{2}$ of $\frac{1}{2}$. Maybe $\frac{4}{5}$ of $\frac{1}{2}$ or $\frac{3}{4}$ of $\frac{1}{2}$.)

3. $\frac{1}{3} \times \frac{3}{4}, \frac{1}{3} \times \frac{4}{6}$

4. $\frac{1}{4} \times \frac{3}{2}, \frac{1}{5} \times 1\frac{1}{2}$

Lesson Synthesis

🕒 10 min

“Today we multiplied a unit fraction by a non-unit fraction.”

Display the diagram from Activity 1 showing a shaded region with side lengths $\frac{6}{5}$ and $\frac{1}{3}$ and the following explanation: “I think the area of the shaded region is $\frac{6}{30}$ because $\frac{6}{10}$ of $\frac{1}{3}$ of the whole thing is shaded.”

Read the explanation aloud.

“What do you think Kiran means?” (I think he thinks that the 2 squares are really 1 square unit.)

“What mistake did Kiran make?” (He is counting all the rows in the rectangle as the denominator instead of the rows in 1 of the unit squares.)

Consider asking students to write a response in their journal and then share their response with a partner.

Suggested Centers

- Rolling for Fractions (3–5), Stage 4: Multiply Fractions (Addressing)
- How Close? (1–5), Stage 7: Multiply Fractions and Whole Numbers to 5 (Supporting)

Complete Cool-Down

Response to Student Thinking

Students do not write an accurate multiplication equation.

Next Day Support

- Before Activity 1, brainstorm a list of strategies for writing equations that represent the area of shaded regions.

Lesson 6: Multiply Fractions

Standards Alignments

Addressing 5.NF.B.4, 5.NF.B.4.b

Teacher-facing Learning Goals

- Represent multiplication of two non-unit fractions with expressions.

Student-facing Learning Goals

- Let's multiply two non-unit fractions using diagrams and expressions.

Lesson Purpose

The purpose of this lesson is for students to calculate areas of rectangles where both side lengths are non-unit fractions.

As in previous lessons, students represent a product of fractions with a diagram. This diagram represents the product $\frac{3}{6} \times \frac{4}{5}$. The diagram shows $\frac{3}{6}$ of $\frac{4}{5}$ of the square so that's $\frac{3}{6} \times \frac{4}{5}$. The number of shaded pieces is 3×4 , the product of the numerators. The number of pieces in the whole square is 6×5 , the product of the denominators. So the value of the product can also be written as $\frac{3 \times 4}{6 \times 5}$. In the first activity, students relate expressions to the area in diagrams like this and then they use this structure to find products of non-unit fractions in the second activity.

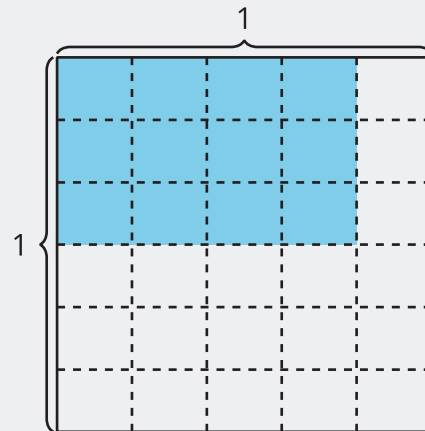

Access for:

🕒 Students with Disabilities

- Action and Expression (Activity 2)

Instructional Routines

Which One Doesn't Belong? (Warm-up)

Lesson Timeline

Warm-up	10 min
Activity 1	15 min
Activity 2	20 min
Lesson Synthesis	10 min
Cool-down	5 min

Teacher Reflection Question

With which math ideas from today's lesson did students grapple most? Did this surprise you or was this what you expected?

Cool-down (to be completed at the end of the lesson)

⌚ 5 min

What is the Area?

Standards Alignments

Addressing 5.NF.B.4.b

Student-facing Task Statement

1. a. Write a multiplication expression to represent the area of the shaded region in square units.

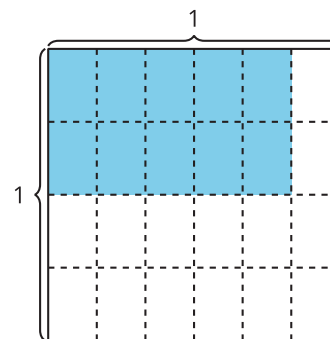

- b. What is the area of the shaded region in square units?

Student Responses

1. a. $\frac{2}{4} \times \frac{5}{6}$ or equivalent
 b. $\frac{10}{24}$ or equivalent

Warm-up

🕒 10 min

Which One Doesn't Belong: More Pieces

The purpose of this warm-up is for students to compare different shaded regions in order to introduce the new type of region that will be considered in this lesson, namely regions where neither side length is a unit fraction. The focus of the discussion is on diagram A where neither side length is a unit fraction.

Instructional Routines

Which One Doesn't Belong?

Student-facing Task Statement

Which one doesn't belong?

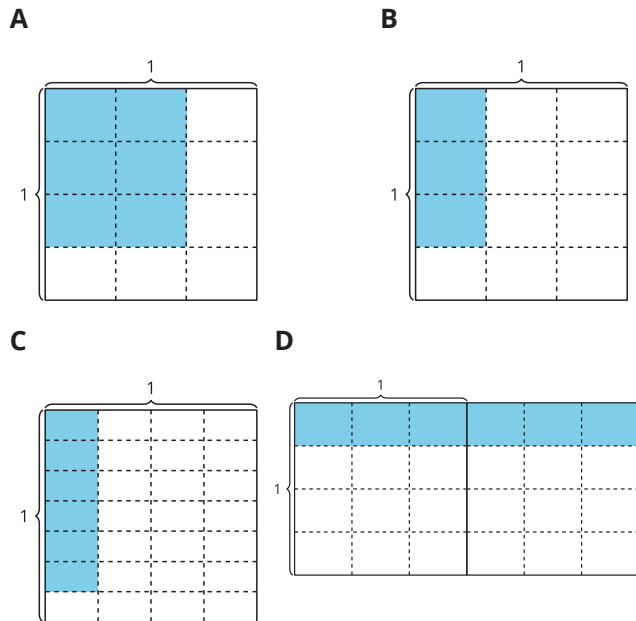

Student Responses

Sample responses:

- A doesn't belong because it doesn't have a side length that is a unit fraction.
- B doesn't belong because it doesn't have 6 shaded pieces.
- C doesn't belong because the whole square is not divided into 12 pieces.

Launch

- Groups of 2
- Display the image.
- "Pick one that doesn't belong. Be ready to share why it doesn't belong."
- 1 minute: quiet think time

Activity

- 2–3 minutes: partner discussion
- Share and record responses.

Synthesis

- "Why doesn't image A belong?" (It's the only one where neither side length is a unit fraction.)
- "What is the area of the shaded region in image A? How do you know?" ($\frac{6}{12}$ because there are 6 shaded pieces and there are 12 pieces in the whole square.)

- D doesn't belong because it is not contained in a single unit square.

Activity 1

🕒 15 min

Many Expressions

Standards Alignments

Addressing 5.NF.B.4.b

The purpose of this activity is for students to relate the structure in an expression to an area diagram (MP7). As students work with their partners, make sure both partners have an opportunity to verbally explain how the diagram represents each expression.

Student-facing Task Statement

Explain or show how each expression can represent the area of the shaded region in square units. Be prepared to share your thinking.

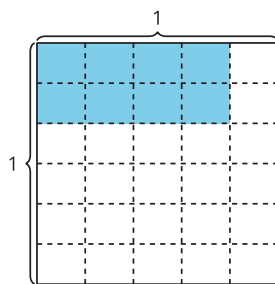

1. $\frac{8}{30}$
2. $2 \times 4 \times \left(\frac{1}{5} \times \frac{1}{6}\right)$
3. $\frac{2}{6} \times \frac{4}{5}$

Student Responses

1. Sample response: There are 8 pieces shaded

Launch

- Groups of 2

Activity

- 2–3 minutes: independent think time
- 5–8 minutes: partner work time
- Monitor for students who can explain how each expression is represented in the diagram.

Synthesis

- Ask previously selected students to share their thinking.
- “How does $\frac{8}{30}$ represent the diagram?” (There are 8 pieces shaded and each piece is $\frac{1}{30}$ of the square.)
- “How does the expression $2 \times 4 \times \left(\frac{1}{5} \times \frac{1}{6}\right)$ represent the diagram?” (The shaded region is a 2 by 4

in and each piece is $\frac{1}{30}$ of the square.

- Sample response: The shaded rectangle is a 2 by 4 array and each of the pieces in the array is $\frac{1}{5}$ of $\frac{1}{6}$ of the whole square.
- Sample response: $\frac{2}{6}$ of $\frac{4}{5}$ of the whole square is shaded.

array and each of the pieces in the array is $\frac{1}{5}$ of $\frac{1}{6}$ of the whole square.)

Advancing Student Thinking

If students do not explain how each expression represents the area of the shaded region, ask: “How would you describe the area of the shaded region?” Connect students’ explanations to the given expressions.

Activity 2

🕒 20 min

More Patterns

Standards Alignments

Addressing 5.NF.B.4

The purpose of this activity is for students to observe and use the structure of diagrams to find areas of shaded regions with non-unit fraction side lengths. Students build on what they learned in the previous activity, solidifying their understanding of why the numerator of a product of two fractions is the product of the numerators and the denominator of a product of fractions is the product of the denominators.

Action and Expression: Internalize Executive Functions. Invite students to verbalize their strategy for writing multiplication expressions to represent the area of the shaded rectangle in each figure before they begin. Students can speak quietly to themselves, or share with a partner.

Supports accessibility for: Organization, Conceptual Processing, Language

Student-facing Task Statement

- Complete the table.

Launch

- Groups of 2

diagram	multiplication expression	shaded area (square units)
<p>A</p> 		
<p>B</p> 		

diagram	multiplication expression	shaded area (square units)
<p>C</p> 		
<p>D</p> 		

Activity

- “Start working on completing the table independently. After a couple minutes, you'll work with your partner to complete the table and answer the rest of the questions.”
- 1–2 minutes: independent work time
- 5–8 minutes: partner work time
- Monitor for students who:
 - notice the area of the shaded regions is always twentieths
 - write the expression $\frac{6}{5} \times \frac{4}{5}$ to represent the shaded region of the last diagram in the table
 - explain that the expression $\frac{6 \times 4}{5 \times 5}$ represents the shaded part of the last diagram in the table because 6×4 represents the number of pieces that are shaded and 4×5 represents the number of those pieces in the unit square

Synthesis

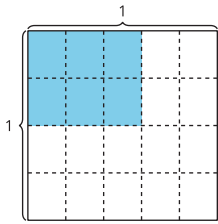
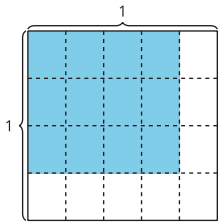
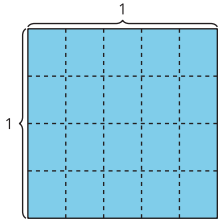
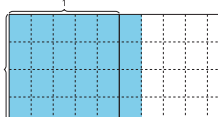
- Ask previously selected students to share their reasoning.
- “How do the expressions in the table represent the number of pieces shaded in and the size of the pieces shaded in?” (If we multiply the numerators, we get the number of pieces that are shaded in. If we multiply the denominators, we get the size of the pieces.)
- Refer to diagrams and draw on each diagram to show how the multiplication of the numerators and denominators represents the number of shaded pieces and the size of the shaded pieces (that is, the number of those pieces in the whole).

2. What patterns do you notice in the table?
3. Explain or show how the expression $\frac{6 \times 4}{5 \times 4}$ represents the last diagram in the table.

Student Responses

1. Sample response:

diagram	expression	area
A	$\frac{2}{4} \times \frac{3}{5}$	$\frac{6}{20}$
B	$\frac{3}{4} \times \frac{4}{5}$	$\frac{12}{20}$
C	$\frac{4}{4} \times \frac{5}{5}$	$\frac{20}{20}$
D	$\frac{4}{4} \times \frac{6}{5}$	$\frac{24}{20}$

2. Sample response: The shaded region looks like it is growing. In the first three diagrams, the shaded region gets longer and wider by one column and one row each time. The area is always equivalent to a certain amount of twentieths.
3. Sample response: The shaded part is a 6 by 4 array and the unit square is a 4 by 5 array. So, there are 24 pieces that are twentieths.

Advancing Student Thinking

If students do not explain that the product of the numerators represents the number of pieces in the shaded region and the product of the denominators represents the number of pieces in the whole, consider asking: "What is the same and what is different about diagrams A and B?"

Lesson Synthesis

🕒 10 min

Display diagram A from the last activity.

Display expression: $\frac{2}{4} \times \frac{3}{5}$

"We can multiply the numerators to find the numerator in the product. How does the diagram represent 2×3 ?" (The shaded pieces are a 2 by 3 array and there are 6 of them.)

“We can multiply the denominators to find the denominator in the product. How does the diagram represent 4×5 ?” (The unit square is a 4 by 5 array so there are 20 pieces in the whole unit square.)

“How does the diagram represent $\frac{6}{20}$?” (There are 6 pieces shaded in they are each $\frac{1}{20}$ of the unit square.)

Suggested Centers

- Rolling for Fractions (3–5), Stage 4: Multiply Fractions (Addressing)
- How Close? (1–5), Stage 7: Multiply Fractions and Whole Numbers to 5 (Supporting)

Complete Cool-Down

Response to Student Thinking

Students do not write a multiplication expression that represents the area of the shaded region.

Next Day Support

- During the launch of Activity 1 in the next lesson, suggest that students adapt the area diagram to show the rows and columns and the relationship of the shaded region to the unit square.

Lesson 7: Generalize Fraction Multiplication

Standards Alignments

Addressing 5.NF.B.4, 5.NF.B.4.a

Teacher-facing Learning Goals

- Generalize to find the product of any 2 fractions.

Student-facing Learning Goals

- Let's use what we've learned to multiply any fractions.

Lesson Purpose

The purpose of this lesson is to generalize strategies for calculating products of fractions.

In this lesson, students find areas of rectangles where the subdivision of each side into unit fractions is not shown. They rely on their understanding of covering the area with appropriate size fractional pieces, understanding that the numerator of the area is the number of those pieces while the denominator is the number of those pieces in 1 square unit. Then students work abstractly with fractions, finding missing values in equations showing products of fractions with no reference to area.

Access for:

Students with Disabilities

- Engagement (Activity 2)

English Learners

- MLR8 (Activity 2)

Instructional Routines

Notice and Wonder (Warm-up)

Lesson Timeline

Warm-up	10 min
Activity 1	20 min
Activity 2	15 min
Lesson Synthesis	10 min
Cool-down	5 min

Teacher Reflection Question

As students described how Diego's diagram represented the expression $\frac{9}{11} \times \frac{5}{8}$, what evidence did you see that they are extending their understanding of multiplication as area?

Cool-down (to be completed at the end of the lesson)

⌚ 5 min

Multiply Fractions

Standards Alignments

Addressing 5.NF.B.4

Student-facing Task Statement

Find the value that makes each equation true.

1. $\frac{3}{4} \times \frac{10}{12} = \underline{\hspace{2cm}}$

2. $\frac{7}{5} \times \underline{\hspace{2cm}} = \frac{42}{15}$

Student Responses

1. $\frac{30}{48}$ or equivalent

2. $\frac{6}{3}$ or equivalent

----- **Begin Lesson** -----**Warm-up**

⌚ 10 min

Notice and Wonder: Two Diagrams

Standards Alignments

Addressing 5.NF.B.4

This Notice and Wonder asks students to consider 2 diagrams representing a shaded region with the same side lengths. The first diagram shows the unit square and the gridlines and the second diagram just shows the side lengths of the shaded region. This prepares students to transition from the gridded diagrams they have worked with in previous lessons to the diagrams they will work with in this lesson. In the activity synthesis, students discuss different equations that represent different ways of finding the area.

Instructional Routines

Notice and Wonder

Student-facing Task Statement

What do you notice? What do you wonder?

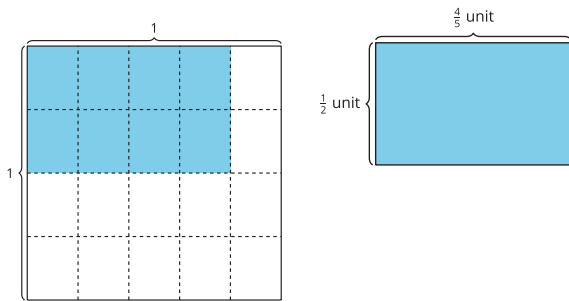

Student Responses

Students may notice:

- In one diagram, you can see the equal pieces.
- The shaded regions have equivalent side lengths, so the areas should be equal.
- You can represent both areas with the expression $\frac{1}{2} \times \frac{4}{5}$.

Students may wonder:

- Do they have the same area?
- How do you calculate the area of the rectangle with no gridlines?

Launch

- Groups of 2
- Display the image.
- “What do you notice? What do you wonder?”
- 1 minute: quiet think time

Activity

- “Discuss your thinking with your partner.”
- 1 minute: partner discussion
- Share and record responses.

Synthesis

- “How do we know that the shaded regions have the same area?” ($\frac{4}{5} \times \frac{2}{4} = \frac{8}{20}$ and $\frac{1}{2} \times \frac{4}{5} = \frac{4}{10} \cdot \frac{8}{20} = \frac{4}{10}$ or $\frac{1}{2} = \frac{2}{4}$, so they must be the same.)
- “How does the first diagram represent this equation: $\frac{8}{20} = \frac{4}{10}$?” (Each of the $\frac{2}{20} = \frac{1}{10}$.)

Activity 1

🕒 20 min

Equations and Area

Standards Alignments

Addressing 5.NF.B.4.a

The purpose of this activity is for students to find the area of rectangles with fractional side lengths where the scaffold of an area diagram is not provided. For the first product, the subdivision of each side into unit fractions is shown and then that is taken away. Without these divisions, students can either try to sketch them or use their understanding of how the numerator and denominator of the fractions relate to

- the total number of shaded pieces in an area diagram
- the total number of shaded pieces in the unit square

When students find products of fractions without an area diagram for support, they rely on their understanding of the meaning of the numerator and denominator and the patterns they have repeatedly observed when finding these products with area diagrams (MP8).

Student-facing Task Statement

1. Find the value of each product. Draw an area diagram if it is helpful.

a. $\frac{2}{5} \times \frac{3}{4}$

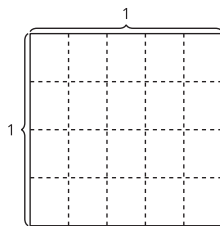

b. $\frac{3}{7} \times \frac{4}{5}$

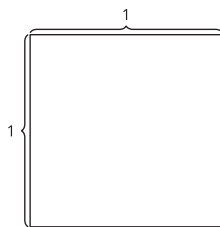

c. $\frac{9}{11} \times \frac{5}{8}$

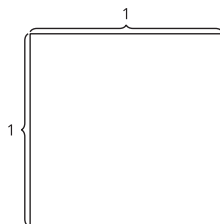

2. How did you decide whether or not to draw

Launch

- Groups of 2
- “You are going to find some products of fractions. You will have a choice of using an area diagram to help you.”

Activity

- 5–8 minutes: independent work time
- 2 minutes: partner discussion
- Monitor for students who:
 - fill in the first diagram which shows the division into smaller pieces
 - try to divide the second diagram into smaller pieces to show the product
 - understand that drawing all of the pieces will be difficult for the third product

Synthesis

- Display expression: $\frac{2}{5} \times \frac{3}{4}$
- Invite students to share their calculations for $\frac{2}{5} \times \frac{3}{4}$.
- “Was the area diagram helpful?” (Yes, it

a diagram? How did the diagrams influence how you found the products?

3. Diego drew this diagram for the product $\frac{9}{11} \times \frac{5}{8}$. How can the diagram help Diego find the value of $\frac{9}{11} \times \frac{5}{8}$?

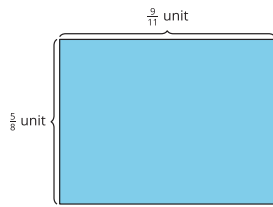

Student Responses

1.

- a. $\frac{6}{20}$. I filled in the diagram.

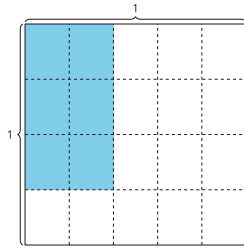

- b. $\frac{12}{35}$. I imagined 3 rows of 4 small pieces with 7×5 or 35 of those pieces filling the square.
- c. $\frac{45}{88}$. I imagined 9 rows of 5 small pieces with 11×8 or 88 of those pieces filling the square.

2. For the first one the little pieces were there so it was easy to fill in. For the second one I thought about dividing up the square but it's hard to divide into 7 equal parts so I just imagined the divisions.
3. The diagram helps Diego visualize the situation. Even though the pieces are not drawn, there are 9 of them along the top 5 down the side. We can't see the whole unit square, but if we could, there would be 11 along the top and 8 down the side. So if the

helped me to visualize the product and understand why 2×3 is the total number of pieces and 5×4 is the number of those pieces in a whole.)

- Display expression: $\frac{9}{11} \times \frac{5}{8}$
- "Did anyone draw an area diagram for this expression?" (I started to and I got the eighths but then gave up for elevenths as that is a hard fraction to show.)
- "Does Diego's diagram help to find the value of $\frac{9}{11} \times \frac{5}{8}$? How?" (Yes, even though it doesn't show any of the parts, having the numbers there helps me see that there would be 9 columns and 5 rows so 45 pieces and that there would be 11 columns and 8 rows in a whole so 88 pieces in a whole.)

pieces were there he could see 9×5 of them with 11×8 in the whole unit square.

Advancing Student Thinking

If students do not represent the unknown side length correctly or find the incorrect value for the area of the shaded region, consider asking: “What do you know about the shaded region? What are you still trying to find out?”

Activity 2

🕒 15 min

Multiply Fractions

Standards Alignments

Addressing 5.NF.B.4.a

The purpose of this activity is for students to find missing values in equations that represent products of fractions. The numbers are complex so students will rely on their understanding of products of fractions rather than on drawing a diagram.

Access for English Learners

MLR8 Discussion Supports. Synthesis: Provide students with the opportunity to rehearse what they will say with a partner before they share with the whole class.

Advances: Speaking

Access for Students with Disabilities

Engagement: Provide Access by Recruiting Interest. Provide choice. Invite students to decide the order to complete the problems.

Supports accessibility for: Attention, Social-Emotional Functioning

Student-facing Task Statement

Find the value that makes each equation true.
Draw a diagram, if it is helpful.

Launch

- Groups of 2

1. $\frac{3}{8} \times \frac{2}{5} = \underline{\hspace{2cm}}$
2. $\frac{3}{4} \times \frac{9}{5} = \underline{\hspace{2cm}}$
3. $\frac{10}{5} \times \frac{6}{5} = \underline{\hspace{2cm}}$
4. $\frac{8}{9} \times \underline{\hspace{2cm}} = \frac{56}{36}$
5. $5 \times \underline{\hspace{2cm}} = \frac{15}{8}$

Student Responses

1. $\frac{3}{8} \times \frac{2}{5} = \frac{6}{40}$ or equivalent
2. $\frac{3}{4} \times \frac{9}{5} = \frac{27}{20}$ or equivalent
3. $\frac{10}{5} \times \frac{6}{5} = \frac{12}{5}$ or equivalent
4. $\frac{8}{9} \times \frac{7}{4} = \frac{56}{36}$ or equivalent
5. $5 \times \frac{3}{8} = \frac{15}{8}$ or equivalent

Activity

- 1–2 minutes: independent think time
- 5–8 minutes: partner work time
- Monitor for students who:
 - use what they know about whole number multiplication to determine that $\frac{8}{9} \times \frac{7}{4} = \frac{56}{36}$
 - use what they know about equivalent fractions to rewrite $\frac{10}{5}$ as 2

Synthesis

- Display:

$$\frac{8}{9} \times \underline{\hspace{2cm}} = \frac{56}{36}$$
- “How did you find the value that makes the equation true?” (I knew the numerator was 7 since $7 \times 8 = 56$ and the denominator had to be 4 since $9 \times 4 = 36$.)
- Display:

$$\frac{10}{5} \times \frac{6}{5} = \underline{\hspace{2cm}}$$
- “How did you know the value that makes the equation true is $\frac{12}{5}$?” (I doubled $\frac{6}{5}$.)
- Display equation: $5 \times \underline{\hspace{2cm}} = \frac{15}{8}$
- “How is this equation different from the others?” (It has a whole number as a factor. The others are all fractions.)
- “How did you solve this problem?” (I knew that the denominator of the missing number had to be 8 to get $\frac{15}{8}$ and then the numerator needed to be 3.)

Advancing Student Thinking

If students do not write the correct missing factors, consider asking, “How did you find the value for the other equations? How can you adapt your strategy to find the missing factors?”

Lesson Synthesis

🕒 10 min

“Today we found the area of rectangles without a grid and we found products of fractions without referring to any area.”

“What do you know about multiplying fractions?” (It is kind of like multiplying whole numbers, but different. We can use some of the strategies we use to multiply whole numbers. We can draw area diagrams to represent equations. The numerator of the product represents the number of pieces and the denominator of the product represents the number of pieces in the whole.)

“How do area diagrams represent products of fractions?” (They show that the product of the numerators is the total number of pieces shaded and the product of the denominators is the size of the pieces that are shaded.)

Display the expression: $\frac{11}{16} \times \frac{7}{8}$

“Would you draw an area diagram to find this product?” (No, because there are so many pieces, but the area diagram helps me picture that there are 11×7 pieces and the size of each piece is 16×8 .)

Suggested Centers

- Rolling for Fractions (3–5), Stage 4: Multiply Fractions (Addressing)
- How Close? (1–5), Stage 7: Multiply Fractions and Whole Numbers to 5 (Supporting)

Complete Cool-Down

Response to Student Thinking

Students do not find the correct value to make each equation true.

Next Day Support

- During the synthesis of the warm-up, prompt students to brainstorm a list of strategies they use to multiply fractions.

Lesson 8: Apply Fraction Multiplication

Standards Alignments

Addressing 5.NF.B.4.a, 5.NF.B.6

Teacher-facing Learning Goals

- Solve problems involving multiplication of fractions.

Student-facing Learning Goals

- Let's solve problems about flags.

Lesson Purpose

The purpose of this lesson is for students to apply what they have learned about fraction multiplication to solve problems.

In previous lessons, students developed an understanding of how to find products of fractions both with an area context and with no context. The purpose of this lesson is to use this knowledge to solve problems about different national flags. Students work with problems where the side lengths are given and they are finding the area in square units of a particular region. They also solve problems where they are determining what fraction of the flag a certain region is. The distinction between these two types of problems is subtle, but is important as the answer to the first problem involves square units but units are not needed for the second problem.

This lesson has a Student Section Summary.

Access for:

Students with Disabilities

- Representation (Activity 2)

English Learners

- MLR7 (Activity 1)

Instructional Routines

Number Talk (Warm-up)

Lesson Timeline

Warm-up	10 min
Activity 1	20 min
Activity 2	15 min

Teacher Reflection Question

As you finish up this section, reflect on the norms and activities that have supported each student in learning math. List ways you have seen each student grow as a young mathematician throughout this work. List ways

Lesson Synthesis

10 min

you have seen yourself grow as a teacher. What will you continue to do and what will you improve on in the next unit?

Cool-down

5 min

Cool-down (to be completed at the end of the lesson)

⌚ 5 min

The Flag of Chad

Standards Alignments

Addressing 5.NF.B.6

Student-facing Task Statement

The area of this flag of Chad is $25\frac{1}{2}$ square centimeters. The blue, yellow, and red sections are all equal. What is the area of the blue part of the flag? Explain or show your reasoning.



Student Responses

$\frac{1}{3} \times 25\frac{1}{2}$ or $\frac{51}{6}$ or $8\frac{1}{2}$ square centimeters or equivalent.

Begin Lesson

Warm-up

⌚ 10 min

Number Talk: Fraction Multiplication

Standards Alignments

Addressing 5.NF.B.4.a

The purpose of this Number Talk is for students to demonstrate strategies and understandings they have for multiplying fractions. These understandings help students develop fluency and will be helpful later in this lesson when students solve problems involving fraction multiplication.

Instructional Routines

Number Talk

Student-facing Task Statement

Find the value of each expression mentally.

- $\frac{1}{3} \times \frac{3}{5}$
- $\frac{2}{3} \times \frac{3}{5}$
- $\frac{5}{3} \times \frac{3}{5}$
- $\frac{2}{3} \times \frac{13}{5}$

Student Responses

- $\frac{3}{15}$ or $\frac{1}{5}$. $\frac{3}{5}$ is equal to $3 \times \frac{1}{5}$ so $\frac{1}{3}$ of those $\frac{3}{5}$ is going to be $\frac{1}{5}$.
- $\frac{6}{15}$ or $\frac{2}{5}$. I doubled the answer from the first problem.
- 1 or $\frac{15}{15}$. $\frac{3}{3} \times \frac{3}{5} = \frac{3}{5}$ and $\frac{2}{3} \times \frac{3}{5} = \frac{2}{5}$ and $\frac{3}{5} + \frac{2}{5} = \frac{5}{5}$ or 1.
- $\frac{26}{15}$ or $1\frac{11}{15}$. I multiplied the numerators to get the numerator in the product and I multiplied the denominators to get the denominator in the product.

Launch

- Display one expression.
- "Give me a signal when you have an answer and can explain how you got it."
- 1 minute: quiet think time

Activity

- Record answers and strategy.
- Keep expressions and work displayed.
- Repeat with each expression.

Synthesis

- "Did you use the same strategy to find the product of the first and last expressions? Why or why not?" (For the first one, it was easy to think about what $\frac{1}{3}$ of $\frac{3}{5}$ was. For the last one, I needed to multiply the numerators and then the denominators because it wasn't easy for me to picture in my head.)

Activity 1

 20 min

Flags

Standards Alignments

Addressing 5.NF.B.6

The purpose of this activity is for students to calculate areas in context. Students are not offered an area diagram but rather an image of a flag. Students may label the image of the flag with measurements or make their own area diagram. The lengths are not always presented in fraction form so students may rewrite them as fractions before calculating areas or they may use the distributive property of multiplication and multiply the whole number and fractional parts separately before adding them. Students reason abstractly and quantitatively when they interpret the given information about the flags and make calculations to solve problems (MP2).

Access for English Learners

MLR7 Compare and Connect. Invite students to prepare a visual display that shows the strategy they used to calculate the area of different parts of the flag. Encourage students to include details that will help others interpret their thinking. For example, specific language, using different colors, shading, arrows, labels, notes, diagrams, or drawings. Give students time to investigate each other's work. During the whole-class discussion, ask students, "What did the approaches have in common?", "How were they different?", and "Did anyone solve the problem the same way, but would explain it differently?"

Advances: Representing, Conversing

Student-facing Task Statement

Launch

- Display image of flags from student workbook.
- "What do you notice? What do you wonder?" (There are lots of different flags, some of the colors are the same, there are a lot of stripes, these flags are from 1968, have any of the flags changed since then?)
- "These are flags from different countries. We are going to solve some problems about flags."
- Groups of 2

Activity

- 2 minutes: quiet think time
- 8–10 minutes: partner work time



Jada has a small replica of a flag of Thailand.



It is 5 inches wide and $7\frac{1}{2}$ inches long.

1. What is the area of the flag? Explain or show your reasoning.
2. Each red stripe is $\frac{5}{6}$ inches wide. What is the area of each red stripe? Explain or show your reasoning.
3. The blue stripe is $\frac{10}{6}$ inches wide. What is the area of the blue stripe? Explain or show your reasoning.

Student Responses

1. $37\frac{1}{2}$ square inches or equivalent. The length is 5 and the width is $7\frac{1}{2}$. Since $5 \times 7 = 35$

- Monitor for students who:
 - notice that the blue stripe is twice as wide as the red stripe and use the area of the red stripe to find the area of the blue stripe
 - find the area of the full flag by converting $7\frac{1}{2}$ to a fraction
 - use the distributive property

Synthesis

- Invite previously selected students to share their solutions.
- Display equation:

$$5 \times 7\frac{1}{2} = (5 \times 7) + (5 \times \frac{1}{2})$$
- “How does the equation represent the area of the flag?” (I can divide the flag into two pieces, one of them 7 inches long, and the other $\frac{1}{2}$ inch long, and then add them to get the area of the flag.)
- Invite students to share responses for the area of the red stripe.
- “How can I use the area of the red stripe to find the area of the blue stripe?” (The blue stripe is twice as wide so its area is twice as much.)

and $5 \times \frac{1}{2} = 2\frac{1}{2}$ or $\frac{5}{2}$, the area is $35 + 2\frac{1}{2}$ or $37\frac{1}{2}$ square inches.

2. $6\frac{3}{12}$ or $\frac{75}{12}$ square inches or equivalent. The length of the red stripe is $7\frac{1}{2}$ or $\frac{15}{2}$ inches and $\frac{5}{6} \times \frac{15}{2} = \frac{75}{12}$.
3. $12\frac{6}{12}$ or $\frac{150}{12}$ square inches or equivalent. The length of the blue stripe is $7\frac{1}{2}$ or $\frac{15}{2}$ inches and $\frac{10}{6} \times \frac{15}{2} = \frac{150}{12}$.

Activity 2

🕒 15 min

More Flags

Standards Alignments

Addressing 5.NF.B.6

The goal of this activity is to examine calculations with measurements of a flag and try to figure out what question the calculations answer. The answers include units and this can serve as a guide to students. Since the first calculation has an answer in inches, the question it answers must ask for a length. Since the second calculation has an answer in square inches, the question it answers must ask for an area. This is an important step in solving the problems as students can then look at the diagram and the measurements and decide what the question could be.

One important part of the modeling cycle (MP4) is interpreting information. That information may be presented in words or graphs or with mathematical symbols. In this case, students interpret equations in light of given numerical relationships and diagrams.

🕒 Access for Students with Disabilities

Representation: Access for Perception. Read the statement aloud. Students who both listen to and read the information will benefit from extra processing time.

Supports accessibility for: Conceptual Processing, Language, Attention

Student-facing Task Statement

Han has a replica of the flag of Colombia.



It is $3\frac{1}{2}$ inches wide and $5\frac{1}{4}$ inches long. The yellow stripe is $\frac{1}{2}$ of the width of the flag and the blue and red stripes are each $\frac{1}{4}$ of the width.

- $\frac{1}{4} \times 3\frac{1}{2} = \frac{7}{8}$. The answer is $\frac{7}{8}$ inch. What is the question?
- $\frac{1}{2} \times 3\frac{1}{2} = \frac{7}{4}$ and $\frac{7}{4} \times \frac{21}{4} = \frac{147}{16}$. The answer is $\frac{147}{16}$ square inches. What is the question?

Student Responses

- Sample responses:
 - What is the width of the blue stripe?
 - What is the width of the red stripe?
- Sample response: What is the area of the yellow stripe?

Launch

- Display image of the flag of Colombia from student workbook.
- "This is the flag of Colombia. It represents independence from Spain on July 20, 1810."
- "What do you notice about the size of each stripe?" (The yellow stripe is about twice the size of each of the blue and red stripes.)
- Display the flag and information about the flag from the activity.
- "A student was answering a question about this flag and wrote $\frac{1}{2} \times 3\frac{1}{2} = 1\frac{3}{4}$."
- "What question do you think the student is answering?" (What is the width of the yellow rectangle?)
- "You are going to solve more problems like this one where you are given the answer and you have to write the question."

Activity

- 4–5 minutes: independent work time
- 3–4 minutes: partner discussion
- Monitor for students who use the units of the answers to help guide them to finding an appropriate question.

Synthesis

- Invite students to share their responses for the first question.
- "How did you know the question was about length?" (The answer is $\frac{7}{8}$ inch, which is the measurement of length. So the question had to be about length.)
- "How did you decide which length?" (The calculation took a quarter of the flag width. Since the red and blue stripes are each $\frac{1}{4}$ of the width, the calculation could be for their width.)

- Invite students to share their responses for the second question.
- “How did you know the question was about area?” (The answer is a measurement in square inches so that’s the area of something.)

Lesson Synthesis

🕒 10 min

“In this section, we have multiplied fractions using area diagrams. What are you most proud of from your work in this section? What questions about fraction multiplication do you still have?”

Suggested Centers

- Rolling for Fractions (3–5), Stage 4: Multiply Fractions (Addressing)
- Compare (1–5), Stage 4: Divide within 100 (Supporting)
- How Close? (1–5), Stage 7: Multiply Fractions and Whole Numbers to 5 (Supporting)

✍ Student Section Summary

In this unit, we learned to multiply fractions. First we learned to multiply unit fractions. For example, we learned that $\frac{2}{5} \times \frac{1}{3} = \frac{2}{15}$.

A

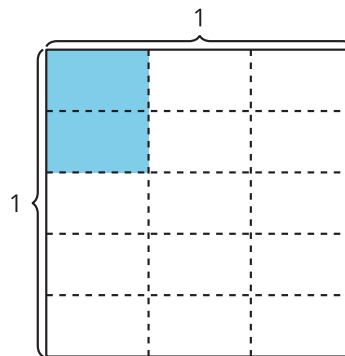

In diagram A, we can see that $\frac{2}{5}$ of $\frac{1}{3}$ of a square is the same size as $\frac{2}{15}$ of the whole square. Next, we learned how to multiply any fraction by a fraction.

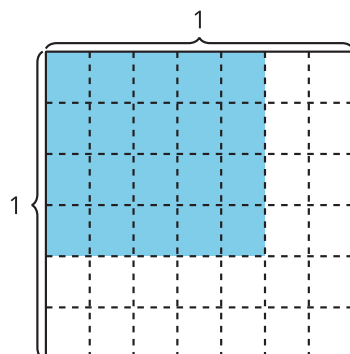
B

In diagram B, we can see that $\frac{4}{6} \times \frac{5}{7} = \frac{20}{42}$. We can multiply the numerators, 4×5 to find the numerator in the product. We can multiply the denominators, 6×7 , to find the denominator in the product. We can represent this relationship with the equation: $\frac{(4 \times 5)}{(6 \times 7)} = \frac{20}{42}$. Diagram B shows 4×5 or 20 pieces with 6×7 or 42 pieces in the whole square.

----- **Complete Cool-Down** -----

Response to Student Thinking

Students don't write a correct solution.

Next Day Support

- Before the next lesson, review the cool-down with students and ask them to explain how much of the whole flag is shaded blue.

Lesson 9: My Own Flag (Optional)

Standards Alignments

Addressing 5.NF.B.6

Building Towards 5.NF.B.6

Teacher-facing Learning Goals

- Solve real world problems involving multiplication of fractions.

Student-facing Learning Goals

- Let's design our own flag.

Lesson Purpose

The purpose of this lesson is for students to design a flag and use multiplication of fractions to determine how much fabric is needed to create the flag.

In this lesson, students are introduced to principles of flag design from the North American Vexillological Association. In the first activity, they make sense of what each principle means and see how they are applicable to a collection of given flags. In the second activity, they design their own flags, solve problems involving area and multiplication of fractions, and share their design with peers.

Access for:

Students with Disabilities

- Engagement (Activity 2)

Instructional Routines

MLR2 Collect and Display (Activity 1), Notice and Wonder (Warm-up)

Materials to Gather

- Colored pencils or crayons: Activity 2
- Paper: Activity 2
- Rulers: Activity 2

Lesson Timeline

Warm-up

10 min

Teacher Reflection Question

Unlike talking, listening is a difficult thing to observe. At what points in the lesson did you

Activity 1	20 min	observe students listening to one another's ideas today in class? What indicators do you have that they were listening?
Activity 2	20 min	
Lesson Synthesis	10 min	

Begin Lesson

Warm-up

🕒 10 min

Notice and Wonder

Standards Alignments

Building Towards 5.NF.B.6

The purpose of this warm-up is for students to discuss the meaning and intention behind flag design, which will be useful when students design their own flag in a later activity. While students may notice and wonder many things about these images, the colors, symbols, and the shapes used in the flag are the important discussion points. In the synthesis, students consider questions to ask the designers of the flag. As an extension to this warm up, students can further explore these questions to learn more about the flag.

Instructional Routines

Notice and Wonder

Student-facing Task Statement

What do you notice? What do you wonder?



Launch

- Groups of 2
- Display the image.
- “What do you notice? What do you wonder?”
- 1 minute: quiet think time

Activity

- “Discuss your thinking with your partner.”
- 1 minute: partner discussion

Student Responses

Students may notice:

- The first image has rectangles.
- The second image has rectangles and something that looks like the sun.
- They look like flags.
- The first image uses the colors blue and white and the second one uses red, blue, and white.

Students may wonder:

- What country are these flags from?
- What do the colors represent?
- What does the sun represent?

- Share and record responses.

Synthesis

- “The first image is the flag of Botswana.” If needed show students where Botswana is on the map.
- “The second image is the flag of Taiwan.” If needed show students where Taiwan is on the map.
- “What are some questions you might ask the designer of these flags?” (What do the different colors represent? Why is there a sun on the second flag?)

Activity 1

🕒 20 min

Principles of Flag Design

Standards Alignments

Building Towards 5.NF.B.6

The purpose of this activity is for students to understand the principles of flag design from the North American Vexillological Association. Students make sense of what each principle means. Then they look at a series of flags and determine which principles the flag most strongly exemplifies. Students will use these principles to create a meaningful flag of their own in the next activity.

This activity uses *MLR2 Collect and Display*. Advances: Conversing, Reading, Writing.

Instructional Routines

MLR2 Collect and Display

Student-facing Task Statement

1. Your teacher will assign you a principle of

Launch

- Display the principles.

flag design. With your partner, discuss what the principle means. Why is the principle important for flag design?

Principles of Good Flag Design

- a. Keep It Simple
 - b. Use Meaningful Symbolism
 - c. Use 2 to 3 Basic Colors
 - d. No Lettering or Seals
 - e. Be Distinctive or Be Related
2. For each flag from the warm up, explain or show how the flag represents the principles of flag design.

a.



b.



Student Responses

1. Sample responses:
 - a. It's so simple that anyone can recognize or make it.
 - b. Everything on the flag represents something. This is important for design because every part of the flag has a purpose and is well thought out.
 - c. It only uses a few colors. This is important to make it less crowded and keeps it simple.
 - d. There is no writing or seal on the flag. This is important because the design of the flag alone communicates something important about the country.
 - e. The flag is unique or if it looks similar to another flag, there is a connection. This is important so that people can recognize the flag easily.

- Assign a principle to each group to ensure that each one is covered.

Activity

MLR2 Collect and Display

- 8 minutes: partner work time
- Circulate, listen for and collect the language students use to describe each principle. Listen for: simple shapes, a few colors, no letters, seals, or stamp, colors mean something, unique, different, related, connection.
- Record students' words and phrases on a visual display and update it throughout the lesson.

Synthesis

MLR2 Collect and Display

- "Are there any other words or phrases that are important to include on our display?"
- As students share responses, update the display, by adding (or replacing) language, diagrams, or annotations.
- Remind students to borrow language from the display as needed.
- "In the next activity, you will use these design principles to create your own flag."
- "Which principle might be the most challenging to follow?" (Be distinctive because there are so many flags already. Mine may not be unique.)

2. Sample response:
 - a. It keeps it simple since the flag is made of only rectangles. It also only uses 3 basic colors.
 - b. It uses meaningful symbolism. The white sun is probably something important to the people of that country. It also only uses 2–3 basic colors.

Activity 2

🕒 20 min

My Flag

Standards Alignments

Addressing 5.NF.B.6

The purpose of this activity is for students to make their own flags and analyze them. Students will use their experience with multiplying fractions to answer area questions related to their flag. Some students may include non-rectangular designs. Encourage them to relate the area of their shape to a rectangle and estimate.

When students design their own flag and determine or estimate the area of each color fabric they need to make the flag they model with mathematics (MP4).

🕒 Access for Students with Disabilities

Engagement: Internalize Self-Regulation. Provide students an opportunity to self-assess and reflect on their own progress. For example, before partner discussion, ask students to reflect on their use of the design principles in their own flag.

Supports accessibility for: Conceptual Processing, Organization

Materials to Gather

Colored pencils or crayons, Paper, Rulers

Required Preparation

- Each student needs a ruler, a set of colored pencils or crayons, and a piece of paper.

Student-facing Task Statement

1. Design your flag.
2. Imagine you are making your flag with fabric. About how much of each color fabric will you need in square inches?
3. Switch flags with a partner.
4. Describe the meaning of each symbol and color you used.
5. How do you see each of the design principles in your partner's flag?

Student Responses

1. Sample response:

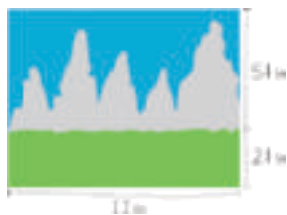

2. I need $30\frac{3}{4}$ square inches of green fabric ($11 \times 2\frac{3}{4} = 30\frac{1}{4}$). The blue and grey colors used are about the same. Together they make up the rest of the flag which is $63\frac{1}{4}$ square inches ($11 \times 5\frac{3}{4} = 63\frac{1}{4}$). And half of that is $31\frac{5}{8}$ square inches.
3. The grey shapes on my flag represent the mountains that my parents grew up around. The green and blue represent the grass and clear sky in the summer when I visit my grandparents who live by the mountains.

Launch

- Give each student white paper.
- "Use the design principles we discussed in the last activity to make your own flag."
- "As you make the design, think about the meaning of each symbol and color you use."

Activity

- 15 minutes: independent work time
- 5 minutes: partner discussion

Synthesis

- Invite a few students to share their flag and describe the different features.

Advancing Student Thinking

If students do not have a strategy to determine how much fabric is needed, ask "What

measurements can help you figure out how much fabric you need?"

Lesson Synthesis

🕒 10 min

"Today we learned about principles of good flag design. We used the design principles to make our own flags with symbols and colors that are important to us. We also found how much fabric we need to make our flag. Why is this information helpful to know?" (It tells us how much material we need. It helps us figure out how much it costs to make. We need to know this if we want to make a lot of flags.)

Suggested Centers

- Rolling for Fractions (3–5), Stage 4: Multiply Fractions (Addressing)
- Compare (1–5), Stage 4: Divide within 100 (Supporting)
- How Close? (1–5), Stage 7: Multiply Fractions and Whole Numbers to 5 (Supporting)

Section B: Fraction Division

Lesson 10: Concepts of Division (Optional)

Standards Alignments

Building On 4.NBT.B.6

Building Towards 5.NF.B.7

Teacher-facing Learning Goals

- Reason about the size of quotients in division problems.

Student-facing Learning Goals

- Let's think about the size of quotients.

Lesson Purpose

The purpose of this lesson is for students to reason about the size of a quotient and consider the relationships between the dividend, divisor, and quotient.

In this optional lesson, students revisit whole number division considering the relationship between dividend, divisor, and quotient. This lesson attends to concepts of division developed since grade 3. Students examine the relationship between the numbers in division problems and compare the size of the quotient by reasoning about the relative sizes of the divisor and dividend. This prepares them to make sense of division involving whole numbers and unit fractions in subsequent lessons.

Access for:

Students with Disabilities

- Representation (Activity 2)

Instructional Routines

MLR2 Collect and Display (Activity 1), Number Talk (Warm-up)

Lesson Timeline

Warm-up	10 min
Activity 1	20 min

Teacher Reflection Question

What did you see or hear in your students' responses today that showed evidence of their understandings of division? How will you

Activity 2	15 min
Lesson Synthesis	10 min
Cool-down	5 min

leverage this understanding in the rest of this section?

Cool-down (to be completed at the end of the lesson)

🕒 5 min

Reason About Division

Standards Alignments

Building Towards 5.NF.B.7

Student-facing Task Statement

1. What new idea did you have about division today?
2. What questions do you have about division with fractions?

Student Responses

Sample responses:

1. There is a pattern that when the dividend remains the same and the divisor gets smaller, the quotient gets larger.
2. Is dividing fractions the same as dividing whole numbers? How do you divide something by $\frac{1}{2}$?

Begin Lesson

Warm-up

🕒 10 min

Number Talk: Same Dividend, Different Divisor

Standards Alignments

Building On 4.NBT.B.6

This Number Talk encourages students to think about the relationship between the size of the divisor and the size of the quotient and to rely on the structure of division expressions to mentally find quotients.

Instructional Routines

Number Talk

Student-facing Task Statement

Find the value of each expression mentally.

- $120 \div 12$
- $120 \div 6$
- $120 \div 3$
- $120 \div 2$

Student Responses

- 10. I know it.
- 20. There are twice as many groups as in the last problem, so there will be half as many in each group.
- 40. 12 divided by 3 is 4. 12 tens divided by 3 is 4 tens.
- 60. I know half of 120 is 60.

Launch

- Display one expression.
- "Give me a signal when you have an answer and can explain how you got it."
- 1 minute: quiet think time

Activity

- Record answers and strategy.
- Keep expressions and work displayed.
- Repeat with each expression.

Synthesis

- "Why did the quotient get bigger with each problem?" (You are making smaller groups so there are more in each of them.)

Activity 1

 20 min

Share Pretzels

Standards Alignments

Building Towards 5.NF.B.7

The purpose of this activity is for students to compare quotients of quantities based on the relative size of the dividend and the divisor. Students should be encouraged to use whatever

strategy makes sense to them to order situations about sharing pretzels. The numbers were intentionally chosen so that students don't have to perform any complex calculations to solve the problem which encourages them to think about the relative size of the numerator and denominator in order to compare the quotients. In upcoming lessons, students will divide a unit fraction by a whole number and a whole number by a unit fraction.

This activity uses *MLR2 Collect and Display*. Advances: Reading, Writing.

Instructional Routines

MLR2 Collect and Display

Student-facing Task Statement

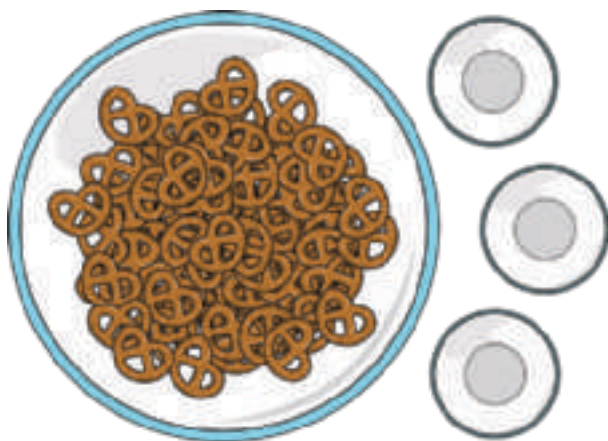

Order the situations from greatest to least based on the number of pretzels each student will get. Be prepared to explain your reasoning.

- 3 students equally share 42 pretzels.
- 14 students equally share 42 pretzels.
- 3 students equally share 24 pretzels.
- 3 students equally share 45 pretzels.
- 7 students equally share 42 pretzels.
- 3 students equally share 6 pretzels.
- 6 students equally share 42 pretzels.

Student Responses

- 3 students equally share 45 pretzels.
- 3 students equally share 42 pretzels.
- 3 students equally share 24 pretzels.

Launch

- Groups of 2
- Display the image of pretzels:

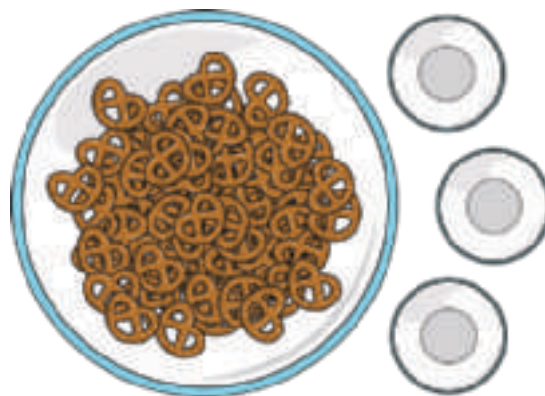

- "What do you notice? What do you wonder?" (I notice that there are a lot of pretzels and 3 bowls. I wonder how many pretzels there are.)

Activity

- 1–2 minutes: quiet think time
- 5–6 minutes: partner work time

MLR2 Collect and Display

- Circulate, listen for, and collect the language students use to describe the relationship between the number of students sharing and the number of

6 students equally share 42 pretzels.
7 students equally share 42 pretzels.
14 students equally share 42 pretzels.
3 students equally share 6 pretzels.

pretzels being shared. Listen for: number in each group, size of the group, number of pretzels each person gets, dividend, divisor, quotient.

- Record students' words and phrases on a visual display and update it throughout the lesson.

Synthesis

- "Are there any other words or phrases that are important to include on our display?"
- As students share responses, update the display, by adding (or replacing) language, diagrams, or annotations.
- Remind students to borrow language from the display as needed.
- Display:
3 students equally share 45 pretzels.
3 students equally share 42 pretzels.
3 students equally share 24 pretzels.
3 students equally share 6 pretzels.
- "What is the same? What is different?" (The same number of students are sharing different numbers of pretzels.)
- "How does the number of pretzels each person gets change in each situation?" (It gets smaller because there are fewer pretzels to share.)
- Display:
14 students equally share 42 pretzels.
7 students equally share 42 pretzels.
6 students equally share 42 pretzels.
- "What is the same? What is different?" (The number of pretzels being shared is the same. The number of students sharing is different.)
- "How does the number of pretzels each person gets change in each situation?" (When fewer people share the same number of pretzels, each person gets more pretzels.)

Advancing Student Thinking

If students do not order the situations correctly, prompt them to draw a diagram to represent each situation and ask, “How are the diagrams the same? How are they different?”

Activity 2

🕒 15 min

Division Patterns

Standards Alignments

Building Towards 5.NF.B.7

The purpose of this activity is for students to look for patterns in division by the same divisor. The numbers in these problems were intentionally chosen so students see that the quotient gets smaller as the dividend gets smaller (MP7). Display the poster of the language students used to describe the relationship between quotient, dividend, and divisor during the previous activity. In the last question, students think about what it means to divide a fraction by a whole number which will be the focus of upcoming lessons.

🕒 Access for Students with Disabilities

Representation: Internalize Comprehension. Synthesis: Invite students to identify which details were needed to solve the problem. Display the sentence frame, “When I calculate quotients, I will pay attention to”

Supports accessibility for: Conceptual Processing, Memory

Student-facing Task Statement

1. Find the value of each expression.

- $36 \div 3$
- $12 \div 3$
- $9 \div 3$
- $6 \div 3$
- $3 \div 3$

Launch

- Groups of 2

Activity

- 5 minutes: independent work time
- Monitor for students who:
 - can explain why the quotient gets smaller when the dividend gets

f. $1 \div 3$

2. What patterns do you notice?
3. Why is the quotient getting smaller?
4. What do you know about this expression:
 $\frac{1}{3} \div 3$?
5. Draw a diagram to represent $\frac{1}{3} \div 3$.

Student Responses

1.
 - a. $36 \div 3 = 12$
 - b. $12 \div 3 = 4$
 - c. $9 \div 3 = 3$
 - d. $6 \div 3 = 2$
 - e. $3 \div 3 = 1$
 - f. $1 \div 3 = \frac{1}{3}$
2. Sample responses: All the problems are about dividing by 3. The number that is being divided gets smaller, so does the quotient.
3. Sample response: It is getting smaller because the number of things being shared is smaller, so there will be fewer in each group.
4. Sample response: It will be smaller than $\frac{1}{3}$, it will be $\frac{1}{3}$ of $\frac{1}{3}$.
5. Sample responses:

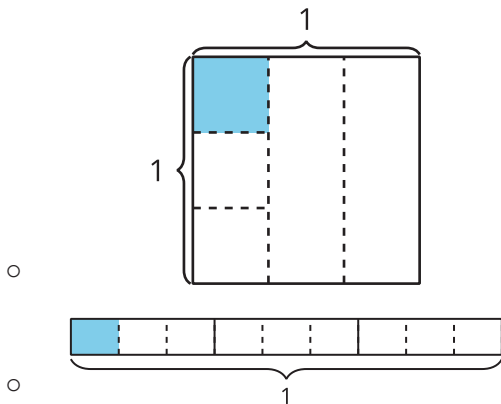

smaller

- describe the quotient of $\frac{1}{3} \div 3$ as being smaller than $\frac{1}{3}$
- draw a diagram to show $\frac{1}{3}$ divided into 3 equal sections

Synthesis

- Ask previously identified students to share their solutions.
- “Why does the quotient get smaller as the dividend gets smaller?” (There are a smaller number of things being split into the same number of groups, so there will be fewer in each group.)
- “Why is $\frac{1}{3} \div 3$ going to be smaller than $\frac{1}{3}$?” ($\frac{1}{3}$ is being divided into 3 equal pieces.)
- Display student diagrams like the ones in student responses.
- “How do the diagrams show $\frac{1}{3} \div 3$?” (They show a third divided into 3 equal pieces.)

Advancing Student Thinking

Students may not immediately visualize the patterns in the division expressions. Encourage them to draw a tape diagram for each expression, and ask them what they notice. Consider asking, “What is happening to the size of each group as the amount being divided gets smaller?”

Lesson Synthesis

🕒 10 min

“Share your new ideas and questions about division from today’s lesson.”

Record responses on a poster to be used in future lessons.

“What do you still wonder about division?” (Can you divide fractions? When would you ever need to divide a fraction? Does the answer get smaller or bigger when you divide fractions?)

Record student responses for all to see. Keep the display visible. Refer back to it in future lessons.

Suggested Centers

- Rolling for Fractions (3–5), Stage 4: Multiply Fractions (Addressing)
- Compare (1–5), Stage 4: Divide within 100 (Supporting)
- How Close? (1–5), Stage 7: Multiply Fractions and Whole Numbers to 5 (Supporting)

Complete Cool-Down

Response to Student Thinking

This lesson builds on concepts of division from a prior unit.

Prior Unit Support

Grade 4, Unit 6, Section C: Multi-digit Division

Lesson 11: Divide Unit Fractions by Whole Numbers

Standards Alignments

Addressing 5.NF.B.7.a
Building Towards 5.NF.B.7.a

Teacher-facing Learning Goals

- Divide a unit fraction by a whole number, in context, in a way that makes sense to them.

Student-facing Learning Goals

- Let's divide a unit fraction by a whole number.

Lesson Purpose

The purpose of this lesson is for students to divide a unit fraction by a whole number.

The purpose of this lesson is for students to determine the size of the piece when a unit fraction is divided into equally sized parts. Students revisit the context of a pan of macaroni and cheese from earlier lessons when they multiplied unit fractions by unit fractions. The familiar context can help students make connections between multiplication and division. Students should be encouraged to solve the problems in a way that makes sense to them. The relationship between multiplication and division is meant to be exploratory. In later lessons, students will formalize this relationship.

Access for:

Students with Disabilities

- Representation (Activity 1)

Instructional Routines

MLR7 Compare and Connect (Activity 1), Number Talk (Warm-up)

Lesson Timeline

Warm-up	10 min
Activity 1	15 min
Activity 2	20 min
Lesson Synthesis	10 min

Teacher Reflection Question

How did the student work you selected impact the direction of the discussion? What student work might you pick next time if you taught the lesson again?

Cool-down

5 min

Cool-down (to be completed at the end of the lesson)

🕒 5 min

Share Macaroni and Cheese

Standards Alignments

Addressing 5.NF.B.7.a

Student-facing Task Statement

1. 6 people equally share $\frac{1}{2}$ a pan of macaroni and cheese.
 - a. Draw a diagram to represent the situation.
 - b. Write a division expression to represent the situation.
 - c. How much of the whole pan does each person get?

Student Responses

1.
 - a. Sample responses: Students may draw a diagram that shows $\frac{1}{2}$ being divided into 6 equal pieces.
 - b. $\frac{1}{2} \div 6$
 - c. $\frac{1}{12}$

----- **Begin Lesson** -----**Warm-up**

🕒 10 min

Number Talk: Double the Divisor

Standards Alignments

Building Towards 5.NF.B.7.a

The purpose of this Number Talk is for students to demonstrate strategies and understandings they

have for dividing whole numbers. These understandings help students develop fluency and will be helpful later in this lesson when students divide a fraction by a whole number.

Instructional Routines

Number Talk

Student-facing Task Statement

Find the value of each expression mentally.

- $72 \div 4$
- $36 \div 4$
- $4 \div 4$
- $1 \div 4$

Student Responses

- 18. $72 \div 2 = 36$ and $36 \div 2 = 18$
- 9. I just knew it.
- 1. There is only 1 group of 4.
- $\frac{1}{4}$. 1 divided into 4 equal pieces is $\frac{1}{4}$.

Launch

- Display one expression.
- “Give me a signal when you have an answer and can explain how you got it.”
- 1 minute: quiet think time

Activity

- Record answers and strategy.
- Keep expressions and work displayed.
- Repeat with each expression.

Synthesis

- “What patterns do you notice in the quotients?” (When the dividend is split in half, the quotient is also split in half.)
- “Why does that happen?” (There are half as many to start with, so there will be half as many in each group.)

Activity 1

🕒 15 min

More Macaroni and Cheese

Standards Alignments

Addressing 5.NF.B.7.a

The purpose of this activity is for students to solve a contextual problem about dividing a fractional amount by a whole number. Students draw a diagram to represent the situation and relate the diagram to a division expression. Because of earlier work in this unit, students may draw one of the familiar square area diagrams showing the product $\frac{1}{3} \times \frac{1}{2}$. Other students may make a diagram resembling the macaroni and cheese pan and divide it appropriately. The focus in the synthesis is on bringing out how the diagram shows $\frac{1}{2} \div 3$ and how it allows students to answer the question. The relationship between $\frac{1}{3} \times \frac{1}{2}$ and $\frac{1}{2} \div 3$ will be brought out in later lessons. When students connect the quantities in the story problem to an equation, they reason abstractly and quantitatively (MP2).

This activity uses *MLR7 Compare and Connect*. Advances: Representing, Conversing.

Access for Students with Disabilities

Representation: Develop Language and Symbols. Represent the problem in multiple ways to support understanding of the situation. For example, a cut-out or another physical manipulative to represent the pan of macaroni and distribute the “macaroni” to three students or a video that shows the distribution of macaroni and cheese between three people.

Supports accessibility for: Attention, Conceptual Processing

Instructional Routines

MLR7 Compare and Connect

Student-facing Task Statement

Jada and her 2 sisters equally share $\frac{1}{2}$ a pan of macaroni and cheese.

1. Draw a diagram to represent the situation.
2. Explain how this expression represents the situation: $\frac{1}{2} \div 3$
3. How much of the whole pan of macaroni and cheese will each person get?

Student Responses

1. Sample responses:

Launch

- Groups of 2
- Display and read: “Last night, Jada’s aunt baked a pan of macaroni and cheese for dinner. Today, she brought the leftovers to Jada’s home for Jada and her sisters to share.”
- “What do you notice? What do you wonder?” (We solved problems about macaroni and cheese before. I wonder how much macaroni and cheese Jada’s aunt brought.)
- 1–2 minutes: partner discussion

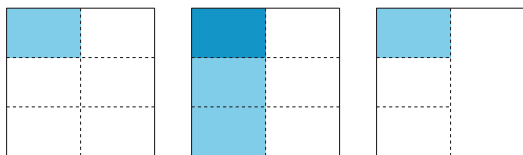

2. Sample response: $\frac{1}{2}$ of the pan of macaroni and cheese is divided into 3 equal pieces.
3. $\frac{1}{6}$ of the whole pan

Activity

- 1–2 minutes: quiet think time
- 6–8 minutes: partner work time
- Monitor for students who:
 - draw diagrams like the ones in the student responses
 - explain the situation as $\frac{1}{2}$ divided into 3 equal pieces
 - recognize each person will get $\frac{1}{6}$ of the whole pan of macaroni and cheese

Synthesis

MLR7 Compare and Connect

- “Create a visual display that shows your thinking about the problems. You may want to include details such as notes, diagrams, drawings, etc., to help others understand your thinking.”
- 2–5 minutes: independent or group work
- 5–7 minutes: gallery walk
- “How does each representation show $\frac{1}{2}$ a pan of macaroni and cheese?”
- “How does each representation show 3 equal pieces?”
- 30 seconds: quiet think time
- 1 minute: partner discussion
- “How do we know that each person got the same amount of macaroni and cheese?” (I divided the half into 3 equal shares.)
- “How much of the whole pan of macaroni and cheese did each person get?” ($\frac{1}{6}$)
- “How do the diagrams show $\frac{1}{6}$?” (Each $\frac{1}{2}$ of the pan is divided into 3 equal pieces, so each of those pieces is $\frac{1}{6}$ of the whole pan.)

Activity 2

🕒 20 min

More People Share

Standards Alignments

Addressing 5.NF.B.7.a

The purpose of this activity is for students to continue to solve problems about dividing a unit fraction by a whole number. The unit fraction in both problems is $\frac{1}{2}$ so that students will consider the relationship between the number of people sharing the macaroni and cheese and the size of the serving each person gets. When students connect the quantities in the story problem to an equation and a diagram representing the story, they reason abstractly and quantitatively (MP2).

Student-facing Task Statement

1. 4 people equally share $\frac{1}{2}$ a pan of macaroni and cheese.
 - a. Draw a diagram to represent the situation.
 - b. Explain how your diagram represents $\frac{1}{2} \div 4$.
 - c. How much of the whole pan of macaroni and cheese did each person get? Be prepared to explain your reasoning.
2. 5 people equally share $\frac{1}{2}$ a pan of macaroni and cheese.
 - a. Draw a diagram to represent the situation.
 - b. Explain how your diagram represents $\frac{1}{2} \div 5$.
 - c. How much of the whole pan of macaroni and cheese did each person get? Be prepared to explain your reasoning.

Launch

- Groups of 2

Activity

- 1–2 minutes: independent think time
- 5–8 minutes: partner work time
- Monitor for students who :
 - draw diagrams like the ones in the student responses
 - describe the amount each person gets as a fraction of the whole pan
 - describe a relationship between the number of people sharing and the size of the serving each person gets

Synthesis

- “How are the situations the same? How are they different?” (Both situations are about $\frac{1}{2}$ a pan of macaroni and cheese, but this one has more people sharing it, so each person gets less macaroni and cheese.)

3. How are the problems the same? How are they different?

Student Responses

- 1.
- a. Diagram shows $\frac{1}{2}$ of the pan divided into 4 equal pieces. Sample responses:
- A**

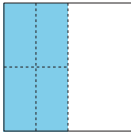

B

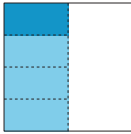

C

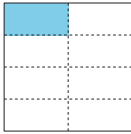
- b. Sample response: I divided half of the pan into 4 equal pieces.
- c. Sample responses: Each person gets $\frac{1}{4}$ of $\frac{1}{2}$ of the pan, or each person gets $\frac{1}{8}$ of the whole pan.
- 2.
- a. Diagram shows $\frac{1}{2}$ the pan divided into 5 equal pieces.
- b. Sample response: I divided half of the pan into 5 equal pieces.
- c. Each person gets $\frac{1}{5}$ of $\frac{1}{2}$, or each person gets $\frac{1}{10}$ of the whole pan.
3. Sample response: Both groups are sharing $\frac{1}{2}$ of a pan of macaroni and cheese, but there are different numbers of people in each group. The amount of macaroni and cheese each person gets is different.

When 4 people share, each person gets $\frac{1}{8}$ of the whole pan. When 5 people share, each person gets $\frac{1}{10}$ of the whole pan.)

Advancing Student Thinking

If students do not identify or explain how much macaroni and cheese each person gets, consider asking, "How much of the whole pan of macaroni and cheese did each person get?"

Lesson Synthesis

🕒 10 min

If you taught the previous optional lesson, display the poster from the previous lesson's synthesis. "What can we add to our poster to show what we learned about division today?" (We can divide unit fractions by whole numbers.)

"How can we show examples of what we learned?" (We can show equations and representations.)

If you did not teach the previous optional lesson, ask: "What did you learn about division today? How can we show examples of what we learned?" Record responses on a poster to be used in future lessons.

"What do you still wonder about division?" (Can you divide fractions? When would you ever need to divide a fraction? Does the answer get smaller or bigger when you divide fractions?)

Record student responses for all to see. Keep the display visible. Refer back to it in future lessons.

Suggested Centers

- Rolling for Fractions (3–5), Stage 4: Multiply Fractions (Addressing)
- Compare (1–5), Stage 4: Divide within 100 (Supporting)
- How Close? (1–5), Stage 7: Multiply Fractions and Whole Numbers to 5 (Supporting)

Complete Cool-Down

Response to Student Thinking

Students' diagrams do not accurately represent the situation, or they do not write a correct division expression.

Next Day Support

- Launch the first activity by asking students to explain how the expression represents the diagram.

Lesson 12: Represent Division of Unit Fractions by Whole Numbers

Standards Alignments

Addressing 5.NF.B.7.a, 5.NF.B.7.b

Teacher-facing Learning Goals

- Make sense of diagrams that represent division of a unit fraction by a whole number.

Student-facing Learning Goals

- Let's make sense of diagrams that represent division of a unit fraction by a whole number.

Lesson Purpose

The purpose of this lesson is for students to use diagrams and equations to represent division of a unit fraction by a whole number.

In the previous lesson, students solved problems about dividing a unit fraction by a whole number in a way that made sense to them. In this lesson, students use tape diagrams to represent division of a unit fraction by a whole number. The tape diagrams used to represent the problems are familiar to students from earlier grades. Here is a tape diagram showing $\frac{1}{4}$, one out of 4 pieces is shaded:

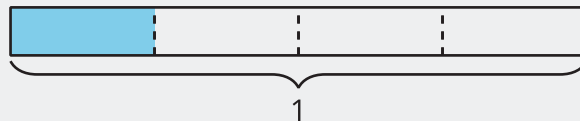

One way to show $\frac{1}{4} \div 3$ is to divide the $\frac{1}{4}$ into 3 equal pieces.

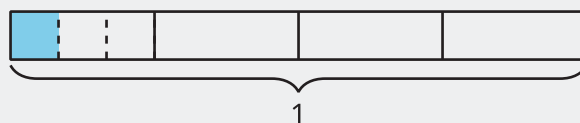

To see how much is shaded we can divide all of the $\frac{1}{4}$ s and see that $\frac{1}{4} \div 3 = \frac{1}{12}$.

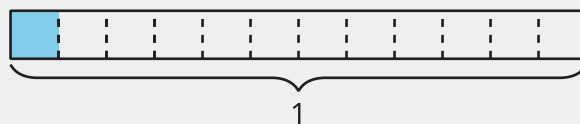

Students use these diagrams to understand this series of steps representing division of a unit fraction by a whole number throughout the lesson.

Access for:**🕒 Students with Disabilities**

- Engagement (Activity 3)

Instructional Routines

Estimation Exploration (Warm-up), MLR3 Clarify, Critique, Correct (Activity 2)

Lesson Timeline

Warm-up	10 min
Activity 1	10 min
Activity 2	10 min
Activity 3	15 min
Lesson Synthesis	10 min
Cool-down	5 min

Teacher Reflection Question

What did you say, do, or ask during the lesson synthesis that helped students be clear on the learning of the day? How did understanding the cool-down of the lesson before you started teaching today help you synthesize that learning?

Cool-down (to be completed at the end of the lesson)

🕒 5 min

Evaluate Division Expressions

Standards Alignments

Addressing 5.NF.B.7.a

Student-facing Task Statement

1.

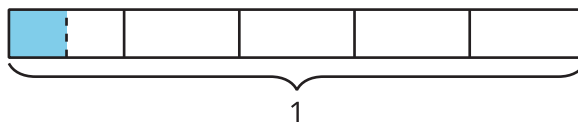

- a. Write a division expression for the shaded region. Explain or show your reasoning.

b. What fraction does the shaded region represent? Explain or show your reasoning.

Student Responses

1. $\frac{1}{5} \div 2$ since the tape is divided into fifths and then the fifth is divided into 2 equal pieces
2. $\frac{1}{10}$ because there are 10 of those pieces in the whole

Begin Lesson

Warm-up

🕒 10 min

Estimation Exploration: How Much is Shaded?

Standards Alignments

Addressing 5.NF.B.7.a

The purpose of this Estimation Exploration is for students to think about dividing a unit fraction into smaller pieces. In the lesson, students will be given extra information so they can determine the exact size of shaded regions like the one presented here.

Instructional Routines

Estimation Exploration

Student-facing Task Statement

How much is shaded?

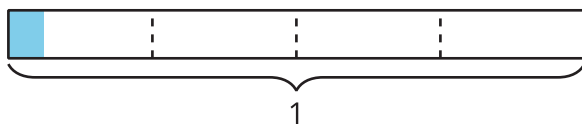

Record an estimate that is:

too low	about right	too high

Launch

- Groups of 2
- Display the image.
- “What is an estimate that’s too high? Too low? About right?”
- 1 minute: quiet think time

Activity

- “Discuss your thinking with your partner.”

Student Responses

Sample responses

- too low: $\frac{1}{100}$ to $\frac{1}{40}$
- about right: $\frac{1}{20}$ to $\frac{1}{16}$
- too high: $\frac{1}{8}$ to $\frac{1}{12}$

- 1 minute: partner discussion
- Record responses.

Synthesis

- Display the image:

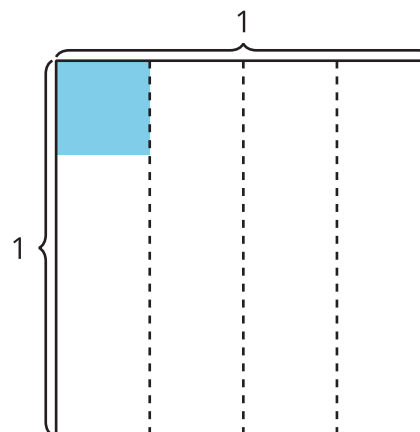

- “How is the tape diagram the same as this area diagram? How is it different?” (Both diagrams show $\frac{1}{4}$ of the whole and then a piece of that $\frac{1}{4}$ is shaded. The tape diagram is long and narrow and the shaded piece is an entire vertical slice. The shaded piece in the area diagram is cut horizontally.)

Activity 1

🕒 10 min

Diagrams, Equations, Situations

Standards Alignments

Addressing 5.NF.B.7.a

In this activity, students interpret division of a unit fraction by a whole number using tape diagrams. In future lessons, students use tape diagrams to understand division of a whole number by a unit fraction. The first two activities are structured so students attend to the structure of the tape diagram and recognize how it can be used to show both a fractional part of a whole being divided into a whole number of pieces and also the size of each resulting piece in relation to the whole. The third activity provides an opportunity for students to begin to notice

structure in equations when dividing a fraction by a whole number.

Student-facing Task Statement

Priya and Mai used the diagrams below to find the value of $\frac{1}{3} \div 4$.

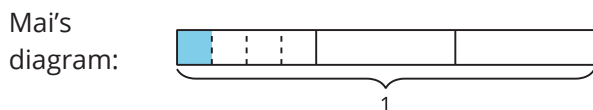
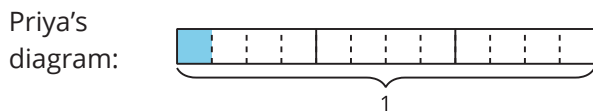

1. What is the same about the diagrams?
2. What is different?
3. Find the value that makes the equation true.

$$\frac{1}{3} \div 4 = \underline{\hspace{2cm}}$$

4. Han drew this diagram to represent $\frac{1}{3} \div 3$.
Explain how the diagram

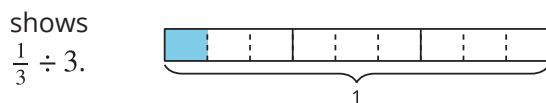

5. Find the value that makes the equation true.
Explain or show your reasoning.

$$\frac{1}{3} \div 3 = \underline{\hspace{2cm}}$$

Student Responses

1. Sample responses: They both show 1 divided into 3 pieces. They both show a shaded blue piece. It looks like the shaded blue piece is the same size. They both show one third divided into 4 pieces.
2. Sample responses: Priya divided the other thirds into 4 pieces and Mai didn't.

Launch

- Groups of 2

Activity

- Monitor for students who:
 - can explain how Mai's diagram shows $\frac{1}{3}$ divided into 4 equal pieces.
 - can explain how Priya's diagram shows that the size of each piece is $\frac{1}{12}$.

Synthesis

- Ask previously selected students to share how Priya and Mai's diagrams are the same and how they are different.
- Display the diagrams that Priya and Mai drew and this equation: $\frac{1}{3} \div 4 = \frac{1}{12}$
- "How does Priya's diagram show $\frac{1}{12}$?" (It is the shaded part. We know it is $\frac{1}{12}$ of the whole because Priya divided all the thirds into 4 pieces.)

3. $\frac{1}{3} \div 4 = \frac{1}{12}$
4. Sample response: $\frac{1}{3}$ is cut into 3 equal pieces. One of the pieces is shaded blue.
5. $\frac{1}{3} \div 3 = \frac{1}{9}$

Advancing Student Thinking

If students do not explain how Priya's diagrams represent the expression $\frac{1}{3} \div 4$, suggest they draw their own diagram to represent the expression and ask, "How is your diagram the same and different from Priya's diagram?"

Activity 2

Priya's Work

 10 min

 PLC Activity

Standards Alignments

Addressing 5.NF.B.7.a

In the previous activity, students explained how tape diagrams represent equations and they used diagrams to find the value of division expressions. In this activity, students examine a mistake in order to recognize the relationship between the number of pieces the fraction is being divided into and the size of the resulting pieces. When students decide whether or not they agree with Priya's work and explain their reasoning, they critique the reasoning of others (MP3).

This activity uses *MLR3 Collect and Display*. Advances: Reading, Writing, Representing.

Instructional Routines

MLR3 Clarify, Critique, Correct

Student-facing Task Statement

1. Find the value of $\frac{1}{3} \div 2$. Explain or show your reasoning.

Launch

- Groups of 2

2. This is Priya's work for finding the value of $\frac{1}{3} \div 2$:

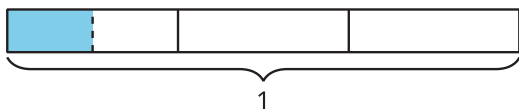

$\frac{1}{3} \div 2 = \frac{1}{2}$ because I divided $\frac{1}{3}$ into 2 equal parts and $\frac{1}{2}$ of $\frac{1}{3}$ is shaded in.

- What questions do you have for Priya?
- Priya's equation is incorrect. How can Priya revise her explanation?

Student Responses

- $\frac{1}{6}$: Students may draw a diagram that shows $\frac{1}{3}$ divided into 2 equal pieces, each of which is $\frac{1}{6}$ of the whole.
- Sample responses:
 - Why didn't you cut the other thirds? Why do you think $\frac{1}{3} \div 2 = \frac{1}{2}$?
 - Sample response: She should change her answer to $\frac{1}{6}$ and cut the other thirds into 2 equal pieces so you can see the sixths.

Activity

- 5 minutes: independent work time
- 3 minutes: partner discussion

Synthesis

MLR3 Clarify, Critique, Correct

- Display the following partially correct answer and explanation:

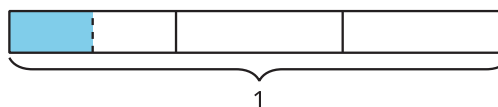

$\frac{1}{3} \div 2 = \frac{1}{2}$ because that is how much is shaded in.

- Read the explanation aloud.
- "What do you think Priya means?" (She shaded in $\frac{1}{2}$ of $\frac{1}{3}$.)
- "Is anything unclear?" (If you divide $\frac{1}{3}$ into 2 pieces, the answer will be smaller than $\frac{1}{3}$ and $\frac{1}{2}$ is larger than $\frac{1}{3}$.)
- "Are there any mistakes?" (The equation should be $\frac{1}{3} \div 2 = \frac{1}{6}$.)
- 1 minute: quiet think time
- 2 minutes: partner discussion
- "With your partner, work together to write a revised explanation."
- Display and review the following criteria:
 - explanation for each step
 - correct solution
 - labeled diagram
- 3–5 minutes: partner work time
- Select 1–2 groups to share their revised explanation with the class. Record responses as students share.
- "What is the same and different about the explanations?"
- Display a revised diagram for Priya's work

or use the one from student responses.

- “Where do we see $\frac{1}{3} \div 2$?” (The shaded section shows one of the pieces if you divide $\frac{1}{3}$ into 2 equal pieces.)
- “Where do we see $\frac{1}{2} \times \frac{1}{3}$?” (The shaded section also shows $\frac{1}{2}$ of $\frac{1}{3}$.)
- “What fraction of the whole diagram is shaded in?” ($\frac{1}{6}$)
- Display: $\frac{1}{3} \div 2 = \frac{1}{3} \times \frac{1}{2}$
- “How do we know this is true?” (We can see both expressions in the diagram and they are both equal to $\frac{1}{6}$.)

Advancing Student Thinking

If students do not find the correct value of $\frac{1}{3} \div 2$, prompt them to draw a diagram to represent the expression.

Activity 3

🕒 15 min

Look for Patterns

Standards Alignments

Addressing 5.NF.B.7.b

In this activity, students notice as the divisor increases for a given dividend, the quotient gets smaller. Students may recognize and explain the relationship between multiplication and division. For example, they may notice that dividing one quarter into two equal pieces is the same as finding the product of $\frac{1}{2} \times \frac{1}{4}$. This relationship is not explicitly brought up in the synthesis, but if students describe this relationship, connect it to the student work that is discussed in the synthesis, as appropriate. When students notice a pattern, they look for and express regularity in repeated reasoning (MP8).

Access for Students with Disabilities

Engagement: Provide Access by Recruiting Interest. Invite students to share a situation in their own lives that could be used to represent one of the division expressions.

Supports accessibility for: Conceptual Processing, Language, Attention

Student-facing Task Statement

- Find the value that makes each equation true. Use a diagram if it is helpful.
 - $\frac{1}{4} \div 2 = \underline{\hspace{2cm}}$
 - $\frac{1}{4} \div 3 = \underline{\hspace{2cm}}$
 - $\frac{1}{4} \div 4 = \underline{\hspace{2cm}}$
- What patterns do you notice?
- How would you find the value of $\frac{1}{4}$ divided by any whole number? Explain or show your reasoning.

Student Responses

- $\frac{1}{4} \div 2 = \frac{1}{8}$
 - $\frac{1}{4} \div 3 = \frac{1}{12}$
 - $\frac{1}{4} \div 4 = \frac{1}{16}$
- The quotient is getting smaller. The denominator in the quotient is the same as 4 times the number of pieces.
- Sample response: I could draw a diagram to show one whole divided into fourths. Then, I could split each $\frac{1}{4}$ into the number of equal pieces that are represented by the whole number and shade one of the pieces in. Finally, I would figure out how much of the whole I shaded in.

Launch

- Groups of 2

Activity

- 1-2 minutes: independent think time
- 3-5 minutes: partner work time

Synthesis

- Display:

$$\frac{1}{4} \div 2 = \frac{1}{8}$$

$$\frac{1}{4} \div 3 = \frac{1}{12}$$

$$\frac{1}{4} \div 4 = \frac{1}{16}$$
- “What patterns do you notice?” (The quotient is getting smaller. The denominator of the quotient is getting bigger. The denominator in the quotient increases by 4. The denominator in the quotient is equal to 4 times the number you are dividing by.)
- “Why is the quotient getting smaller?” (Because we are dividing $\frac{1}{4}$ into more pieces each time, so the size of each piece will be smaller.)

Advancing Student Thinking

If students do not explain how they would find the value of $\frac{1}{4}$ divided by any whole number, prompt them to find the value of $\frac{1}{4} \div 5$ and $\frac{1}{4} \div 6$ and ask, “What is the relationship between the divisor and the quotient?”

Lesson Synthesis

🕒 10 min

Display the expression, $\frac{1}{3} \div 3$ and Han’s diagram from the lesson:

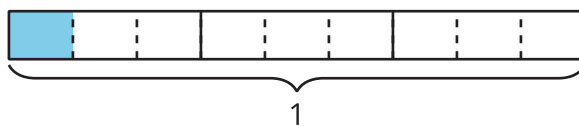

“How does Han’s diagram represent the expression?” (The whole diagram is divided into three equal pieces and each third is divided into three equal pieces.)

“What does the shaded part of the diagram represent?” ($\frac{1}{9}$ of the whole.)

Suggested Centers

- Rolling for Fractions (3–5), Stage 4: Multiply Fractions (Addressing)
- Compare (1–5), Stage 4: Divide within 100 (Supporting)
- How Close? (1–5), Stage 7: Multiply Fractions and Whole Numbers to 5 (Supporting)

Complete Cool-Down

Response to Student Thinking

Students do not write $\frac{1}{5} \div 2 = \frac{1}{10}$.

Next Day Support

- Create a poster that displays students’ strategies for dividing a unit fraction by a whole number.

Lesson 13: Divide Whole Numbers by Unit Fractions

Standards Alignments

Addressing 5.NF.B.7.b
Building Towards 5.NF.B.7.b

Teacher-facing Learning Goals

- Divide a whole number by a unit fraction in context, in a way that makes sense to them.

Student-facing Learning Goals

- Let's divide a whole number by a unit fraction.

Lesson Purpose

The purpose of this lesson is for students to solve division problems in a way that makes sense to them.

In this lesson students investigate dividing a whole number by a unit fraction using the context of strips of paper. In the warm-up, they describe what they notice and wonder about a picture of a quilt. During Activity 1, they consider cutting paper strips and using the strips to make a paper quilt. In Activity 2, as they did for division of a unit fraction by a whole number, students use a tape diagram which has the additional advantage of resembling the strips of paper. They observe how the quotient depends on the size of the dividend and represent the quotient with an equation. It may be helpful for students to actually make paper quilts. If possible, cut 2 foot length pieces of construction paper in various colors before the lesson and ask students to follow the directions in the problem prompts to make smaller pieces of each color. After the lesson, students can use the pieces to create a paper quilt.

Access for:

Students with Disabilities

- Representation (Activity 2)

Instructional Routines

MLR2 Collect and Display (Activity 1), Notice and Wonder (Warm-up)

Required Preparation

If students will be making My Way quilts, create 2 foot long pieces of construction paper in red, yellow, and green.

Lesson Timeline

Warm-up	10 min
Activity 1	20 min
Activity 2	15 min
Lesson Synthesis	10 min
Cool-down	5 min

Teacher Reflection Question

How did students think about division as they came into the lesson? In what ways did their understanding of division change upon completing the lesson?

Cool-down (to be completed at the end of the lesson)

🕒 5 min

A Different Strip of Paper

Standards Alignments

Addressing 5.NF.B.7.b

Student-facing Task Statement

Han has a strip of paper that is 3 feet long. He cuts it into pieces that are $\frac{1}{4}$ foot long. How many pieces are there? Explain or show your reasoning.

Student Responses

12 pieces. Each foot will have 4 pieces, so that is 12 pieces all together.

----- **Begin Lesson** -----

Warm-up

🕒 10 min

Notice and Wonder: Quilt

Standards Alignments

Building Towards 5.NF.B.7.b

The purpose of this warm-up is for students to describe the rectangles in the representation of a quilt, which will be useful when students divide strips of paper into unit fraction sized pieces in a later activity. While students may notice and wonder many things about this image, the variety of lengths and colors of fabric strips is the important discussion point.

Instructional Routines

Notice and Wonder

Student-facing Task Statement

What do you notice? What do you wonder?



Student Responses

Students may notice:

- There is a woman sewing a quilt.
- There is string and scissors.
- There is a kid watching.

Students may wonder:

- Who is that woman?
- What does the rest of the blanket look like?
- Did she sew the whole thing?

Launch

- Groups of 2
- Display the image.
- “What do you notice? What do you wonder?”
- 1 minute: quiet think time

Activity

- “Discuss your thinking with your partner.”
- 1 minute: partner discussion
- Share and record responses.

Synthesis

- “These pictures show women from Gee’s Bend, Alabama, who have been making quilts for generations. How would you describe the quilt they are working on?” (It is colorful. There are rectangles. There are different colored pieces of fabric.)
- Consider showing students examples of abstract or improvised quilts by Gee’s Bend Quiltmakers from the website of Souls Grown Deep.

Activity 1

Paper Strips

🕒 20 min

Standards Alignments

Addressing 5.NF.B.7.b

The purpose of this activity is for students to solve problems about dividing a whole number by a unit fraction in a way that makes sense to them. The context of quilt making is used so students can visualize a strip of paper that is a whole number length being cut into fractional sized pieces. As students describe how the problems are similar and different, listen for the authentic language they use to describe division. The paper strip, or tape, is a helpful diagram to use when dividing a whole number by a unit fraction because students recognize important relationships between the divisor, dividend, and quotient (MP7). For example, if the length of the strip stays the same, but the size of the piece gets smaller, then the number of pieces will get bigger.

This activity uses *MLR2 Collect and Display*. Advances: Conversing, Reading, Writing.

Instructional Routines

MLR2 Collect and Display

Student-facing Task Statement

Below are diagrams that show strips of different colored paper. Each strip is 2 feet long. The paper strips will be cut into different sized pieces.

1. The red strip will be cut into pieces that are $\frac{1}{2}$ foot long. How many pieces will there be?

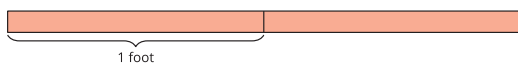

2. The green strip will be cut into pieces that are $\frac{1}{3}$ foot long. How many pieces will there be?

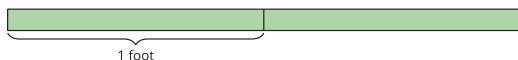

3. The yellow strip will be cut into pieces that are $\frac{1}{4}$ foot long. How many pieces will there be?

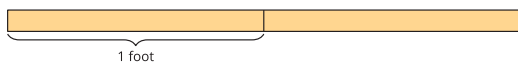

4. Describe what was the same about the

Launch

- Groups of 2
- Refer to the picture from the warm up.
- "If the blue strip of fabric under the woman's chin is 1 meter long, about how long is the short gray strip next to it?" ($\frac{1}{6}$ meter)

Activity

- 1-2 minutes: independent think time
- 8-10 minutes: partner work time

MLR2 Collect and Display

- Circulate, listen for, and collect the language students use to describe what was the same and different about the strategies they used to determine the number of pieces of paper for each color. Listen for:
 - The size of the piece changed.

problems you solved. Describe what was different.

Student Responses

1. 4 pieces
2. 6 pieces
3. 8 pieces
4. Sample responses: All of the problems were about a piece of paper that was 2 feet long. For each problem, I was cutting the two feet into smaller pieces. The size of the piece got smaller each time, so there were more pieces.

- The pieces were shorter.
- There were more pieces.
- I made more cuts.

- Record students' words and phrases on a visual display and update it throughout the lesson.

Synthesis

- "Are there any other words or phrases that are important to include on our display?"
- As students share responses, update the display by adding (or replacing) language, diagrams, or annotations.
- Remind students to borrow language from the display as needed.
- Display:

$$2 \div \frac{1}{2} = 4$$

$$2 \div \frac{1}{3} = 6$$

$$2 \div \frac{1}{4} = 8$$
- "How do these equations represent the problems about the paper strips?" (The 2 is for 2 feet of paper, and the fractions show the size of the pieces that the paper is being cut into. The 4, 6, and 8 are the number of pieces of each color of paper.)

Advancing Student Thinking

Students may not immediately make a connection with the situation and division, since the number of pieces that results (the quotient) is greater than the number of feet being divided (the dividend). Consider asking, "How does this situation represent division?" Allow students to recognize that the cuts are similar to partitions in a diagram, or sharing. They may also recognize that the quotient represents the number of groups, while the fraction being divided is the size of each group. Have them write a division equation for each situation, if it helps. They will write division equations in the next activity.

Activity 2

🕒 15 min

More Paper Strips

Standards Alignments

Addressing 5.NF.B.7.b

The purpose of this activity is for students to represent division of a whole number by a unit fraction with diagrams and equations. The context is the same as the previous activity so students can use a tape diagram to solve the problem, if they choose. In the previous activity, students recognized that when the length of paper stays the same and the size of the piece gets smaller, there are more pieces of paper. In this activity, students will consider what happens when the length of the paper changes, but the size of the pieces stays the same.

🕒 Access for Students with Disabilities

Representation: Access for Perception. Provide access to strips of paper for students to cut and fold. Ask students to identify correspondences between the number of pieces/folds and the fraction they represent.

Supports accessibility for: Conceptual Processing, Memory

Student-facing Task Statement

Kiran has a yellow strip of paper that is 2 feet long. He wants to cut the strip into pieces that are $\frac{1}{6}$ foot long.

1. How many pieces will Kiran have? Explain or show your reasoning.
2. Write a division equation to represent the situation.
3. Describe how the equation $3 \div \frac{1}{6} = 18$ represents a strip of paper that is 3 feet long being cut into equal-sized pieces.

Student Responses

1. Sample response: Each foot will have 6

Launch

- Groups of 2

Activity

- 1–2 minutes: independent think time
- 6–8 minutes: partner work time
- Monitor for students who:
 - determine that Kiran will have 12 pieces of paper
 - can explain how the equation $2 \div \frac{1}{6} = 12$ represents the yellow strip of paper being cut into $\frac{1}{6}$ -foot strips
 - describe the equation $3 \div \frac{1}{6} = 18$ as

pieces and there are 2 feet so that is 12 pieces. $(6 \times \frac{1}{6}) + (6 \times \frac{1}{6}) = 2$, so that is 12 pieces altogether, $12 \times \frac{1}{6} = 2$.

2. $2 \div \frac{1}{6} = 12$
3. Sample response: A three foot piece of paper is cut into pieces that are $\frac{1}{6}$ of a foot long so there are 18 pieces.

representing a 3 foot strip of paper being cut into 18 pieces that are each $\frac{1}{6}$ of a foot long

Synthesis

- Ask previously identified students to share their solutions.
- Display: $2 \div \frac{1}{6} = 12$
- "How does this equation represent the yellow strip of paper?" (The strip of paper is 2 feet long and it is cut into pieces that are $\frac{1}{6}$ of a foot long so there will be 12 pieces.)
- Display: $3 \div \frac{1}{6} = 18$
- "How does this equation represent a different strip of paper being cut into equal sized pieces?" (A 3 foot piece of paper is cut into pieces that are $\frac{1}{6}$ of a foot long so there are 18 pieces.)
- "Why is the quotient larger than the dividend in both of these equations?" (Because you are cutting a whole number length into fractional sized pieces, so there will be more pieces than when you started.)

Advancing Student Thinking

If students do not write an equation that represents the situation, show them $2 \div \frac{1}{6}$ and ask, "How does this expression represent the situation?"

Lesson Synthesis

 10 min

"Today, we solved problems about cutting strips of paper into small pieces. We wrote equations to represent dividing a whole number by a unit fraction."

Display:

$$2 \div \frac{1}{2} = 4$$

$$2 \div \frac{1}{3} = 6$$

$$2 \div \frac{1}{4} = 8$$

$$2 \div \frac{1}{6} = 12$$

“These are some of the equations we discussed today. Why is the quotient getting larger in each equation?” (Because the size of the piece is getting smaller, so there will be more pieces.)

Display: $3 \div \frac{1}{6} = 18$

“Here is another equation we discussed. In this equation, the size of the piece is the same as the equation above it. Why is the quotient larger than when 2 is divided by $\frac{1}{6}$?” (3 is being divided into smaller pieces, instead of 2, so you get more pieces.)

“We are going to learn more about the relationships between the numbers in division equations with unit fractions in the next lesson.”

Suggested Centers

- Rolling for Fractions (3–5), Stage 4: Multiply Fractions (Addressing)
- Compare (1–5), Stage 4: Divide within 100 (Supporting)
- How Close? (1–5), Stage 7: Multiply Fractions and Whole Numbers to 5 (Supporting)

Complete Cool-Down

Response to Student Thinking

If students do not identify the correct amount of pieces.

Next Day Support

- During the synthesis of the warm-up, ask students how the division equations could represent paper strips being cut into certain sized pieces.

Lesson 14: Represent Division of Whole Numbers by Unit Fractions

Standards Alignments

Addressing 5.NF.B.7.b

Teacher-facing Learning Goals

- Divide a whole number by a unit fraction.
- Relate diagrams, situations and expressions that represent division of a whole number by a unit fraction.

Student-facing Learning Goals

- Let's solve problems involving division of a unit fraction by a whole number.

Lesson Purpose

The purpose of this lesson is for students to solve problems involving division of a unit fraction by a whole number and write equations to represent them.

In the previous lesson, students solved problems involving division of a whole number by a unit fraction. In this lesson, students continue to find quotients of a whole number by a unit fraction. In this lesson, however, they find the value of expressions without being provided a tape diagram. The numbers are not too large, however, so they may still draw a diagram if it is helpful. In the second activity, students look simultaneously at expressions involving quotients of a whole number by a fraction and quotients of a fraction by a whole number.

Access for:

Students with Disabilities

- Action and Expression (Activity 1)

Instructional Routines

MLR7 Compare and Connect (Activity 1), Number Talk (Warm-up)

Lesson Timeline

Warm-up

10 min

Teacher Reflection Question

Reflect on times you observed students listening to one another's ideas today in class. What

Activity 1	20 min
Activity 2	15 min
Lesson Synthesis	10 min
Cool-down	5 min

norms would help each student better attend to their classmates' ideas in future lessons?

Cool-down (to be completed at the end of the lesson)

🕒 5 min

Solve and Match the Expression

Standards Alignments

Addressing 5.NF.B.7.b

Student-facing Task Statement

- A package has 2 cups of raisins. Each serving of raisins is $\frac{1}{4}$ cup.
 - Does this situation match the expression $2 \div \frac{1}{4}$ or $\frac{1}{4} \div 2$? Explain or show your reasoning.
 - How many servings of raisins are there in the package? Explain or show your reasoning.

Student Responses

- $2 \div \frac{1}{4}$ since the 2 cups is being divided into servings that are each $\frac{1}{4}$ cup.
 8. Sample response: each cup has four $\frac{1}{4}$ cup so that's 8 total.

----- Begin Lesson -----

Warm-up

🕒 10 min

Number Talk: Increasing Quotients

Standards Alignments

Addressing 5.NF.B.7.b

The purpose of this Number Talk is for students to demonstrate strategies and understandings they have for dividing a whole number by a unit fraction. These understandings will be helpful later in this lesson when students match situations to equations and solve the equations.

Instructional Routines

Number Talk

Student-facing Task Statement

Find the value of each expression mentally.

- $6 \div 1$
- $6 \div \frac{1}{2}$
- $6 \div \frac{1}{3}$
- $6 \div \frac{1}{6}$

Student Responses

- 6. I just know it.
- 12. There are 2 halves in one whole and there are 6 so $6 \times 2 = 12$.
- 18. There are 3 pieces of $\frac{1}{3}$ in 1 whole so there will be 6 times as many pieces in 6 wholes.
- 36. The pieces are half as big as in the previous expression, so there will be twice as many groups.

Launch

- Display one expression.
- "Give me a signal when you have an answer and can explain how you got it."
- 1 minute: quiet think time

Activity

- Record answers and strategy.
- Keep expressions and work displayed.
- Repeat with each expression.

Synthesis

- "Why is the quotient getting larger with each problem?" (Because we are dividing the same number into smaller sized groups so there are going to be more groups.)

Activity 1

🕒 20 min

Notice Patterns

Standards Alignments

Addressing 5.NF.B.7.b

The purpose of this activity is for students to find quotients of a whole number by a unit fraction and observe patterns in how the size of the numerator and denominator influence the size of the quotient. Whereas students were provided a tape diagram in the previous lesson, here they may draw a diagram but they may also reason about the size of the quotients in other ways. When students notice a pattern or repetitive action in computation, they are looking for and expressing regularity in repeated reasoning (MP8).

This activity uses *MLR7 Compare and Connect*. Advances: Representing, Conversing.

Access for Students with Disabilities

Action and Expression: Internalize Executive Functions. Invite students to plan a strategy, including the tools they will use, for finding the value of each statement. If time allows, invite students to share their plan with a partner before they begin.

Supports accessibility for: Conceptual Processing, Organization

Instructional Routines

MLR7 Compare and Connect

Student-facing Task Statement

Set A: Find the value that makes each equation true. Draw a diagram if it is helpful. What patterns do you notice?

- $3 \div \frac{1}{4} = \underline{\quad}$
- $4 \div \frac{1}{4} = \underline{\quad}$
- $5 \div \frac{1}{4} = \underline{\quad}$
- $6 \div \frac{1}{4} = \underline{\quad}$

Set B: Find the value that makes each equation true. Draw a diagram if it is helpful. What patterns do you notice?

- $3 \div \frac{1}{2} = \underline{\quad}$
- $3 \div \frac{1}{3} = \underline{\quad}$
- $3 \div \frac{1}{4} = \underline{\quad}$
- $3 \div \frac{1}{5} = \underline{\quad}$

What is the same about problem set A and B?

Launch

- Groups of 2
- “Decide with your partner who will work on set A and who will work on set B.”

Activity

- 3–5 minutes: independent work time
- 3–5 minutes: partner discussion

Synthesis

MLR7 Compare and Connect

- “Work with your partner to create a visual display that shows your thinking about how the problem sets are the same and different. You may want to include details such as notes, diagrams, drawings, etc., to help others understand your thinking.”
- 2–5 minutes: independent or group work
- 5–7 minutes: gallery walk

What is different?

Student Responses

Set A

Sample response: 12, 16, 20, 24

The quotient gets larger by 4 each time. All of the problems divide a whole number by $\frac{1}{4}$. The quotient is the whole number multiplied by the denominator.

Set B

Sample response: 6, 9, 12, 15

The quotient gets larger by 3 each time. All of the problems are dividing 3 into fractional sized groups. The quotient is the whole number multiplied by the denominator.

In both sets, the quotient is getting bigger by the same amount each time. In one set, the fraction changes, and in the other set, the whole number changes.

- “What is the same and what is different between the two sets of problems?”
- 30 seconds: quiet think time
- 1 minute: partner discussion
- Additional connections could include:
 - “What is changing in each problem set?” (The size of the number being divided is changing in set A and the size of the piece the number is being divided into is changing in problem set B.)
 - “If the patterns continued, what would be the next equation in each set?”
- “Why is the quotient getting larger in both sets of problems?” (In set A, it is getting larger because you have 4 more $\frac{1}{4}$ size pieces in each additional whole. In set B, it is getting larger because the size of the piece is getting smaller, so you have more of them.)

Advancing Student Thinking

If students don't solve the equations correctly, prompt them to draw diagrams to represent each equation and ask: “How does each diagram represent the equation?”

Activity 2

🕒 15 min

Match the Situation to the Expression

Standards Alignments

Addressing 5.NF.B.7.b

The purpose of this activity is for students to match situations to expressions and then find the value of the expressions (MP2). Students see expressions that show both quotients of a whole

number by a fraction and quotients of a fraction by a whole number. They need to think carefully about the situations to make sure the expression they choose matches the situation (MP2).

Student-facing Task Statement

1. Match each problem to an expression that represents the problem. Some expressions will not have a match. Be prepared to explain your reasoning.

- a. One serving of popcorn is $\frac{1}{4}$ cup of kernels. There are 3 cups of kernels in the bowl. How many servings are in the bowl?

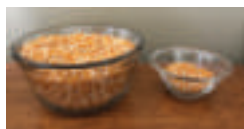

- b. One serving of orange juice is $\frac{1}{4}$ liter. The container of juice holds 2 liters. How many servings are in the container?

- c. One serving of granola is $\frac{1}{2}$ cup. The bag of granola holds 5 cups. How many servings are in the bag?

$$\frac{1}{4} \div 3$$

$$\frac{1}{2} \div 5$$

$$3 \div \frac{1}{4}$$

$$\frac{1}{4} \div 2$$

$$5 \div \frac{1}{2}$$

$$2 \div \frac{1}{4}$$

2. Find the value of each expression.

Student Responses

1. a. $3 \div \frac{1}{4}$
 b. $2 \div \frac{1}{4}$
 c. $5 \div \frac{1}{2}$

Launch

- Groups of 2
- Display the image from student book:

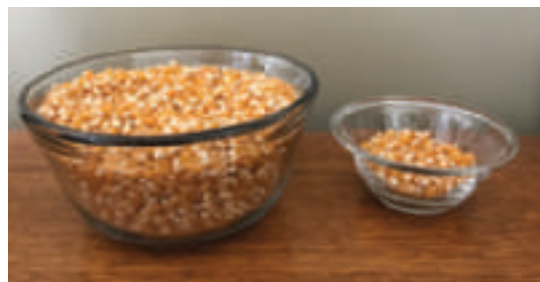

- “What do you notice? What do you wonder?” (They look like seeds. How many are in the bowls? Why are there 2 bowls?)
- “The small bowl is filled with $\frac{1}{4}$ cup of kernels. That is one serving of popcorn kernels. What does ‘one serving’ mean?” (It is the amount you are supposed to eat at one time.)
- “About how many servings are in the big bowl?” (Answers vary. Sample responses range from 10 to 15.)

Activity

- 1–2 minutes: independent think time
- 5–8 minutes: partner work time
- Monitor for students who:
 - draw diagrams to represent the situations
 - describe the relationship between the dividend and divisor using language such as “groups of”
 - use the value of the expression to describe why the expression

2. $\frac{1}{4} \div 3 = \frac{1}{12}$
 $3 \div \frac{1}{4} = 12$
 $5 \div \frac{1}{2} = 10$
 $\frac{1}{2} \div 5 = \frac{1}{10}$
 $\frac{1}{4} \div 2 = \frac{1}{8}$
 $2 \div \frac{1}{4} = 8$

matches the situation

Synthesis

- Ask previously selected students to share their solutions.
- “How did you decide which expression matched which situation?” (I thought about the number of things being divided and whether it was a fraction or a whole number. I thought about the size of the pieces.)
- Display: $3 \div \frac{1}{4} = 12$
- “Describe how this equation represents the situation in the first problem.” (There are 3 cups of kernels in the bowl and a serving is $\frac{1}{4}$ a cup, so there are 12 servings in the bowl.)
- Display: $\frac{1}{4} \div 3 = \frac{1}{12}$
- “How do you know that this equation does not match the situation?” (The answer is a fraction. That doesn’t make sense because there is more than 1 serving in 3 cups.)

Advancing Student Thinking

If students do not correctly match the situations to the expressions, refer to each situation and ask, “How does the situation represent division?”

Lesson Synthesis

🕒 10 min

“Today we used expressions to represent and solve problems involving the division of a whole number by a unit fraction.”

Display: “Jada says when you divide a whole number by a unit fraction, the answer will always be greater than 1.”

“Do you agree with Jada? Be prepared to explain your thinking.” (I think so, because there will always be more than 1 unit fraction in a whole number, so even if it was 1 divided by a unit fraction, there will be however many unit fractions make up 1 whole, so that will be a whole number of unit fractions.)

Suggested Centers

- Compare (1–5), Stage 8: Divide Fractions and Whole Numbers (Addressing)
- Rolling for Fractions (3–5), Stage 5: Divide Unit Fractions and Whole Numbers (Addressing)

Complete Cool-Down

Response to Student Thinking

Students do not find the correct value of their expression.

Next Day Support

- Launch the second activity by asking students to explain whether they think the value of each expression will be greater than or less than 1.

Lesson 15: Fraction Division Situations

Standards Alignments

Addressing 5.NF.B.7, 5.NF.B.7.c

Teacher-facing Learning Goals

- Write situations and solve problems involving dividing a unit fraction and a whole number.

Student-facing Learning Goals

- Let's write division situations and solve problems involving division of whole numbers and unit fractions.

Lesson Purpose

The purpose of this lesson is for students to write and solve problems that involve dividing a whole number by a unit fraction and a unit fraction by a whole number.

In previous lessons, students learned how to divide a whole number by a unit fraction and a unit fraction by a whole number. They reasoned about relationships between dividends, divisors, and quotients. In this lesson, students apply what they have learned in this section to write and solve problems involving division of a whole number by a unit fraction and division of a unit fraction by a whole number. Before they solve the problems, they match each one with an equation. As students match each problem with an equation, they interpret the meaning of the equation in a context (MP2).

Access for:

Students with Disabilities

- Engagement (Activity 1)

English Learners

- MLR8 (Activity 1)

Instructional Routines

Card Sort (Activity 1), Number Talk (Warm-up)

Materials to Copy

- Fraction Division Problem Sort (groups of 2): Activity 1

Required Preparation

Gather poster from previous lesson that explains what students know and wonder about division of a unit fraction by a whole number.

Lesson Timeline

Warm-up	10 min
Activity 1	20 min
Activity 2	15 min
Lesson Synthesis	10 min
Cool-down	5 min

Teacher Reflection Question

What strategies did you anticipate today? Which did you not anticipate? What did you learn about student understanding from the strategies you did not anticipate?

Cool-down (to be completed at the end of the lesson)

⌚ 5 min

Match and Solve

Standards Alignments

Addressing 5.NF.B.7.c

Student-facing Task Statement

1. Match each expression to a situation. Answer each question.

- $5 \div \frac{1}{4}$
- $\frac{1}{4} \div 5$

- a. Han cut 5 feet of ribbon into pieces that are $\frac{1}{4}$ foot long. How many pieces are there?
- b. Han cut a $\frac{1}{4}$ foot long piece of ribbon into 5 equal pieces. How long is each piece?

Student Responses

1. a. $5 \div \frac{1}{4} = 20$. There are 20 pieces.
- b. $\frac{1}{4} \div 5 = \frac{1}{20}$. Each piece is $\frac{1}{20}$ foot long.

----- **Begin Lesson** -----

Warm-up

 10 min

Number Talk

Standards Alignments

Addressing 5.NF.B.7

The purpose of this Number Talk is for students to demonstrate strategies and understandings they have for dividing a whole number by a unit fraction and a unit fraction by a whole number. These understandings help students develop fluency and will be helpful later in this lesson when students solve division problems.

Instructional Routines

Number Talk

Student-facing Task Statement

Find the value of each expression mentally.

- $6 \div 3$
- $6 \div \frac{1}{3}$
- $\frac{1}{3} \div 6$
- $\frac{1}{3} \div 12$

Student Responses

- 2. I just know it.
- 18. $6 \times 3 = 18$
- $\frac{1}{18} \cdot \frac{1}{3} \div 6 = \frac{1}{18}$
- $\frac{1}{36}$. There are twice as many pieces as in the previous expression so the pieces will be twice as small.

Launch

- Display one expression.
- "Give me a signal when you have an answer and can explain how you got it."
- 1 minute: quiet think time

Activity

- Record answers and strategy.
- Keep expressions and work displayed.
- Repeat with each expression.

Synthesis

- "How are the expressions $6 \div \frac{1}{3}$ and $\frac{1}{3} \div 6$ the same? How are they different?" (They both have a 6 and a $\frac{1}{3}$ but $6 \div \frac{1}{3}$ is greater than 1 and $\frac{1}{3} \div 6$ is less than 1.)

Activity 1

⌚ 20 min

Card Sort: Fraction Division Problem Sort

Standards Alignments

Addressing 5.NF.B.7.c

The purpose of this activity is for students to match situations and expressions and then answer the questions asked about the situations. The numbers used in the problems are deliberately chosen so that students cannot make the matches just by looking at the numbers. Considering expressions that represent situations will help students as they write their own situations in the next activity. A sorting task gives students opportunities to analyze representations, statements, and structures closely and make connections (MP2, MP7).

Access for English Learners

MLR8 Discussion Supports. Students should take turns finding a match and explaining their reasoning to their partner. Display the following sentence frames for all to see: “I noticed _____, so I matched” Encourage students to challenge each other when they disagree. *Advances: Conversing, Representing*

Access for Students with Disabilities

Engagement: Develop Effort and Persistence. Chunk this task into more manageable parts. Give students a subset of the cards to start with and introduce the remaining cards once students have completed their initial set of matches. *Supports accessibility for: Attention; Organization*

Instructional Routines

Card Sort

Materials to Copy

Fraction Division Problem Sort (groups of 2)

Required Preparation

- Create a set of cards from the Instructional master for each group of 2.

Student-facing Task Statement

1. Your teacher will give you a set of cards. Match each expression with a situation. Some expressions do not have a matching situation.
2. Answer each question. Be prepared to share your reasoning.

Student Responses

A and E. 9 servings

B and F. 12 servings

C and G. 8 times

D and H. 12 pieces

I and M. $\frac{1}{9}$ pan

J and N. $\frac{1}{12}$ pound

K and P. $\frac{1}{8}$ mile

Launch

- Groups of 2
- Give each group a set of pre-cut cards.

Activity

- “This set of cards includes situations and expressions. Match each situation to an expression. Work with your partner to justify your choices.”
- 8 minutes: partner work time
- “Work together to answer the question in each situation.”
- 8 minutes: partner work time
- If students do not have enough time to answer all of the questions, use the problems as a center.

Synthesis

- Ask students to share the matches they made and how they know those cards go together.
- Attend to the language that students use to describe their matches, giving them opportunities to describe the kind of division happening in the situation more precisely.
- Highlight the use of terms that reference the number of groups and the size of the group.

Advancing Student Thinking

If students do not correctly match situations to expressions, have students draw a diagram for each situation. Consider asking, “Do any of the expressions match the diagram you drew?” and ask students to explain why the match makes sense.

Activity 2

🕒 15 min

Division Story Situations

Standards Alignments

Addressing 5.NF.B.7.c

The purpose of this activity is for students to write situations involving division of a whole number by a unit fraction and division of a unit fraction by a whole number. They may use one of the contexts from the stories in the previous activity, changing the quantities suitably, or they may make up their own. Consider having a gallery walk for students to see the variety of story problems.

Student-facing Task Statement

1. Choose one of the expressions from the card sort that didn't have a match. Write a situation that matches the expression.
2. Trade situations with another group and answer their question.

Student Responses

1. Sample response: There is $\frac{1}{4}$ of a pound of cherries. I split them equally with a friend. How many pounds of cherries did we each get? This story matches the expression $\frac{1}{4} \div 2$.

Launch

- Groups of 2-4

Activity

- 3–5 minutes: partner work time
- 3–5 minutes: small-group work time
- Monitor for students who write “how many in each group” stories and “how many groups” stories and invite them to share, highlighting the differences in the situations.

Synthesis

- Invite students to share problems (or have a gallery walk).

Advancing Student Thinking

If students don't think of a situation that makes sense, ask them to think about one of the contexts from earlier in the unit and describe the equation using that context. For example, the paper strips or the macaroni and cheese.

Lesson Synthesis

🕒 10 min

Display chart from a previous lesson.

“What can we add to our chart to show what we learned about division in this section?”

Suggested Centers

- Compare (1–5), Stage 8: Divide Fractions and Whole Numbers (Addressing)
- Rolling for Fractions (3–5), Stage 5: Divide Unit Fractions and Whole Numbers (Addressing)
- How Close? (1–5), Stage 6: Multiply to 3,000 (Supporting)

Complete Cool-Down

Response to Student Thinking

Students don't match each situation to the correct expression.

Next Day Support

- Before the next lesson, match students up to discuss a correct response to the cool-down.

Lesson 16: Reason About Quotients

Standards Alignments

Addressing 5.NF.B.7, 5.NF.B.7.b

Teacher-facing Learning Goals

- Assess the reasonableness of quotients.
- Divide unit fractions and whole numbers.

Student-facing Learning Goals

- Let's apply what we know about division to make sure our answers make sense.

Lesson Purpose

The purpose of this lesson is for students to find quotients involving a whole number and a unit fraction and assess the reasonableness of their answers.

In previous lessons students found the value of quotients of a unit fraction and a whole number. In this lesson they think about comparing the value of these quotients without calculating. For example, students know from earlier work that $48 \div 4$ is less than $48 \div 2$ because there are more groups of 2 in 48 than groups of 4. By the same reasoning $10 \div \frac{1}{3}$ is less than $10 \div \frac{1}{5}$ because $\frac{1}{5}$ s are smaller than $\frac{1}{3}$ s and so it takes more $\frac{1}{5}$ s to make an amount. This kind of reasoning also shows that $\frac{1}{4} \div 15$ is less than $\frac{1}{4} \div 12$ because dividing the same amount into more pieces creates smaller pieces.

Access for:

Students with Disabilities

- Engagement (Activity 1)

Instructional Routines

Estimation Exploration (Warm-up), MLR1 Stronger and Clearer Each Time (Activity 1)

Lesson Timeline

Warm-up	10 min
Activity 1	20 min
Activity 2	15 min
Lesson Synthesis	10 min

Teacher Reflection Question

Reflect on a time your thinking changed about something in class recently. How will you alter your teaching practice to incorporate your new understanding?

Cool-down

5 min

Cool-down (to be completed at the end of the lesson)

🕒 5 min

Both Types of Problems

Standards Alignments

Addressing 5.NF.B.7

Student-facing Task Statement

Which is greater, $5 \div \frac{1}{3}$ or $\frac{1}{3} \div 5$. Explain or show your reasoning.

Student Responses

Sample response: $5 \div \frac{1}{3}$ is greater than $\frac{1}{3} \div 5$. $5 \div \frac{1}{3}$ is greater than 1 because there are a lot more than one thirds in 5. $\frac{1}{3} \div 5$ is less than 1 because $\frac{1}{3}$ is being divided into smaller pieces.

----- **Begin Lesson** -----**Warm-up**

🕒 10 min

Estimation Exploration: How Many One Fifths?

Standards Alignments

Addressing 5.NF.B.7.b

The purpose of this Estimation Exploration is for students to apply their understanding of dividing a whole number by a fraction from previous lessons. The dividend in this expression is much larger than those that students have previously worked with to encourage students to use multiplication to estimate.

Instructional Routines

Estimation Exploration

Student-facing Task Statement

$$98 \div \frac{1}{5}$$

Record an estimate that is:

too low	about right	too high

Student Responses

Sample responses

- too low: 400 to 450
- about right: 470 to 499
- too high: 500 or more

Launch

- Groups of 2
- Display the expression.
- “What is an estimate that’s too high? Too low? About right?”
- 1 minute: quiet think time

Activity

- “Discuss your thinking with your partner.”
- 1 minute: partner discussion
- Record responses.

Synthesis

- “How do you know the value of $98 \div \frac{1}{5}$ is less than 500?” (It’s less than $100 \div \frac{1}{5}$ and that’s 500)

Activity 1

 20 min

Greater Than or Less Than 1

Standards Alignments

Addressing 5.NF.B.7

The purpose of this activity is for students to reason about the size of quotients, involving a unit fraction and a whole number, by carefully analyzing the relative sizes of the dividend and divisor rather than finding the value of the expressions. As students work, listen for the language they use to explain why they think the value of an expression is greater than or less than 1. Highlight the language during the synthesis. When students explain to each other how they decided whether a quotient is greater than 1 or less than 1 they construct viable arguments (MP3).

This activity uses *MLR1 Stronger and Clearer Each Time*. Advances: Reading, Writing.

Access for Students with Disabilities

Engagement: Provide Access by Recruiting Interest. Synthesis: Optimize meaning and value. Invite students to share if a previously selected expression is less than or greater than one and how they determined the value of the expression (display of their work on a problem, strategy they used, verbal explanation with a classmate who missed the lesson).

Supports accessibility for: Attention, Conceptual Processing, Memory

Instructional Routines

MLR1 Stronger and Clearer Each Time

Student-facing Task Statement

$$25 \div \frac{1}{5} \qquad \frac{1}{7} \div 25 \qquad \frac{1}{8} \div 25$$

$$25 \div \frac{1}{7} \qquad 25 \div \frac{1}{8} \qquad \frac{1}{5} \div 25$$

- Without finding the value of the expressions, write each expression under the correct category.

The value of the expression is less than 1

The value of the expression is greater than 1

- Explain your strategy for determining whether a quotient is less than 1 or greater than 1.

Student Responses

- less than 1: $\frac{1}{7} \div 25$, $\frac{1}{8} \div 25$, $\frac{1}{5} \div 25$
greater than 1: $25 \div \frac{1}{5}$, $25 \div \frac{1}{7}$, $25 \div \frac{1}{8}$
- Sample response: I thought about the size of the whole and the size or number of pieces it is being divided into. A whole that's less than 1 divided into many pieces is less than 1. There are more than 1 pieces of size less than 1 in a whole whose size is greater than

Launch

- Groups of 2

Activity

- 1–2 minutes: quiet think time
- 5–8 minutes: partner work time

Synthesis

MLR1 Stronger and Clearer Each Time

- “Share your explanation for determining whether a quotient is less than or greater than 1 with your partner. Take turns being the speaker and the listener. If you are the speaker, share your ideas and writing so far. If you are the listener, ask questions and give feedback to help your partner improve their work.”
- 3–5 minutes: structured partner discussion.
- Repeat with 2–3 different partners.
- If needed, display question starters and prompts for feedback.
 - “Can you give an example to help show . . . ?”
 - “How can you use the words divisor

1.

and dividend in your explanation?"

- "Revise your initial draft based on the feedback you got from your partners."
- 2–3 minutes: independent work time

Activity 2

⌚ 15 min

Estimate and Divide

Standards Alignments

Addressing 5.NF.B.7

The purpose of this activity is for students to order the quotients from the previous activity from least to greatest, without calculating. The quotients of a whole number by a unit fraction have the same dividend so students reason that the expression with the smallest unit fraction divisor represents the largest quotient. In the same way, the quotients of a unit fraction by a whole number all have the same divisor so the expression with the largest unit fraction dividend is the largest.

Student-facing Task Statement

$$25 \div \frac{1}{5} \quad \frac{1}{7} \div 25 \quad \frac{1}{8} \div 25$$

$$25 \div \frac{1}{7} \quad 25 \div \frac{1}{8} \quad \frac{1}{5} \div 25$$

1. Without finding the value of the expressions, put the expressions in order from least to greatest.
2. Choose 2 expressions and find the value of the expressions.

Student Responses

1. $\frac{1}{8} \div 25$, $\frac{1}{7} \div 25$, $\frac{1}{5} \div 25$, $25 \div \frac{1}{5}$, $25 \div \frac{1}{7}$,
 $25 \div \frac{1}{8}$

Launch

- Groups of 2

Activity

- 5 minutes: independent work time
- 5 minutes: partner discussion
- Monitor for students who:
 - explain that the greatest quotient is $25 \div \frac{1}{8}$ because it represents the largest number of pieces
 - explain that the smallest quotient is $\frac{1}{8} \div 25$ because it represents the smallest sized piece

2. Sample responses: $\frac{1}{8} \div 25 = \frac{1}{200}$,
 $\frac{1}{7} \div 25 = \frac{1}{175}$, $\frac{1}{5} \div 25 = \frac{1}{125}$, $25 \div \frac{1}{5} = 125$,
 $25 \div \frac{1}{7} = 175$, $25 \div \frac{1}{8} = 200$

- change their response after the partner discussion

Synthesis

- Ask previously selected students to explain their reasoning.
- “What was challenging about this activity?” (It was hard to explain without finding any values.)
- “How did reasoning about the order of the expressions help you find the value of 2 of the expressions?” (I knew the value was going to be a unit fraction [or whole number].)

Advancing Student Thinking

Students may confuse the strategies for dividing a whole number by a unit fraction with dividing a unit fraction by a whole number. Ask:

- “Will the quotient be greater than or less than the dividend?”

Lesson Synthesis

🕒 10 min

Display:

$$25 \div \frac{1}{\square}$$

“What do we know about the value of this expression if the number in the box is a whole number?” (It is going to be greater than 25. It is going to be a multiple of 25.)

Display:

$$\frac{1}{\square} \div 25$$

“What do we know about the value of this expression if the number in the box is a whole number?” (It is going to be a unit fraction. The denominator is going to be a multiple of 25.)

Suggested Centers

- Compare (1–5), Stage 8: Divide Fractions and Whole Numbers (Addressing)
- Rolling for Fractions (3–5), Stage 5: Divide Unit Fractions and Whole Numbers (Addressing)
- How Close? (1–5), Stage 6: Multiply to 3,000 (Supporting)

Complete Cool-Down

Response to Student Thinking

Students did not write reasonable answers.

Next Day Support

- During the activities, ask students to draw a picture or act out a problem before solving.

Section C: Problem Solving with Fractions

Lesson 17: Fraction Multiplication and Division Situations

Standards Alignments

Addressing 5.NF.B.4, 5.NF.B.6, 5.NF.B.7

Teacher-facing Learning Goals

- Solve problems involving multiplication and division with fractions.

Student-facing Learning Goals

- Let's solve problems involving multiplying and dividing fractions.

Lesson Purpose

The purpose of this lesson is for students to solve multiplication and division problems with fractions with an emphasis on making sense of the problems and the operation needed to solve them.

Earlier in this unit students learned how to multiply and how to divide a whole number by a unit fraction or a unit fraction by a whole number. In this lesson, they solve a variety of problems some of which encourage representing and solving with a specific operation.

Access for:

Students with Disabilities

- Engagement (Activity 2)

Instructional Routines

MLR4 Information Gap (Activity 1), Number Talk (Warm-up)

Materials to Copy

- Info Gap: Tiles (groups of 2): Activity 1

Lesson Timeline

Warm-up	10 min
Activity 1	20 min
Activity 2	15 min
Lesson Synthesis	10 min
Cool-down	5 min

Teacher Reflection Question

Think about a recent time from class when your students were confused. What did you do to support them in reasoning about their confusion together as a community of learners?

Cool-down (to be completed at the end of the lesson)

⌚ 5 min

How Much Milk?

Standards Alignments

Addressing 5.NF.B.6

Student-facing Task Statement

1. A container has 2 cups of milk in it. How many $\frac{1}{4}$ cups of milk are in the container? Explain or show your reasoning.
2. A container has 2 cups of milk in it. The container is $\frac{1}{3}$ full. How many cups does the container hold? Explain or show your reasoning.

Student Responses

1. $2 \div \frac{1}{4} = 8$
2. $2 \div \frac{1}{3} = 6$ or $3 \times 2 = 6$.

----- **Begin Lesson** -----**Warm-up**

⌚ 10 min

Number Talk: Multiply and Divide

Standards Alignments

Addressing 5.NF.B.4, 5.NF.B.7

The purpose of this Number Talk is for students to demonstrate strategies and understandings they have for multiplying and dividing fractions. These understandings help students develop fluency and will be helpful later in this lesson when students solve problems about multiplying and dividing fractions.

Instructional Routines

Number Talk

Student-facing Task Statement

Find the value of each expression mentally.

- $5 \div \frac{1}{6}$
- $5 \times \frac{1}{6}$
- $\frac{1}{5} \div 6$
- $\frac{1}{5} \times \frac{1}{6}$

Student Responses

- 30. I multiplied 5 by 6.
- $\frac{5}{6}$. I just knew it.
- $\frac{1}{30}$. I found $\frac{1}{6}$ of $\frac{1}{5}$.
- $\frac{1}{30}$. I found the product of the numerators and denominators.

Launch

- Display one expression.
- "Give me a signal when you have an answer and can explain how you got it."
- 1 minute: quiet think time

Activity

- Record answers and strategy.
- Keep expressions and work displayed.
- Repeat with each expression.

Synthesis

- "How are the last two problems related?" (Dividing by 6 and multiplying by $\frac{1}{6}$ give the same result.)

Activity 1

Info Gap: Tiles

 20 min

 PLC Activity

Standards Alignments

Addressing 5.NF.B.6, 5.NF.B.7

This Info Gap activity gives students an opportunity to determine and request the information needed to solve multi-step problems involving multiplication and division of unit fractions. In both cases, the student with the problem card needs to find out the side lengths of the area being covered and the size of the tiles and from there they can figure out how many tiles are needed. The numbers in the problems are chosen so that students can draw diagrams or perform arithmetic directly with the numbers.

In this Info Gap activity, the first problem encourages students to think about multiplying the given fractions. The second problem involves a given area and a missing side length, which may encourage students to represent and solve the problem with a missing factor equation.

The Info Gap structure requires students to make sense of problems by determining what information is necessary, and then to ask for information they need to solve it. This may take several rounds of discussion if their first requests do not yield the information they need (MP1). It also allows them to refine the language they use and ask increasingly more precise questions until they get the information they need (MP6).

Instructional Routines

MLR4 Information Gap

Materials to Copy

Info Gap: Tiles (groups of 2)

Required Preparation

- Create a set of cards from the Instructional master for each group of 2.

Student-facing Task Statement

Your teacher will give you either a problem card or a data card. Do not show or read your card to your partner.

If your teacher gives you the *problem card*:

1. Silently read your card and think about what information you need to answer the question.

Launch

- Groups of 2

Activity

- Explain the Info Gap structure, and consider demonstrating the protocol if students are unfamiliar with it.
- 15 minutes: partner work time

2. Ask your partner for the specific information that you need.
3. Explain to your partner how you are using the information to solve the problem.
4. Solve the problem and explain your reasoning to your partner.

If your teacher gives you the *data card*:

1. Silently read the information on your card.
2. Ask your partner, "What specific information do you need?" and wait for your partner to ask for information. Only give information that is on your card. (Do not figure out anything for your partner!)
3. Before telling your partner the information, ask, "Why do you need that information?"
4. After your partner solves the problem, ask them to explain their reasoning and listen to their explanation.

Pause here so your teacher can review your work. Ask your teacher for a new set of cards and repeat the activity, trading roles with your partner.

Student Responses

1. 384 tiles. Sample response: The floor is 8×8 or 64 square feet. I can arrange 6 of the tiles to cover a square foot. So I need 64×6 or 384 tiles to cover the entire floor.
2. 5 boxes with 2 tiles left. Sample response: I can use 40 tiles in a box to make an 8 foot by $1\frac{1}{4}$ foot rectangle and there are 2 tiles left. So with 5 boxes I can cover an 8 by $6\frac{1}{4}$ foot rectangle with 10 tiles left. If I make one 8 foot by $\frac{1}{4}$ foot rectangle with 8 of those tiles, that fills up the 8 foot by $6\frac{1}{2}$ foot rectangle with 2 tiles left over.

- After you review their work on the first problem, give them the cards for a second problem and instruct them to switch roles.
- Monitor for students who:
 - Draw pictures to arrange the tiles and see how they can fit the tiles together to cover the area.
 - Use division and multiplication in their calculations.

Synthesis

- Invite students to share their responses to the problem about tiling the floor.
- "How did you know whether to use multiplication or division to solve the problem?" (I needed to use multiplication to find the area of the floor. I also used multiplication to figure out how many tiles I needed.)
- "How did you solve the problem?" (I found out how many tiles I needed for one square foot by drawing a picture and then multiplied that by the number of square feet in the floor.)
- Invite students to share their responses to the problem about the tiles for the wall.
- "How did you know whether to use multiplication or division?" (I used multiplication to figure out how many square feet of the wall I could cover with each box and how many square feet were in the wall.)
- "How did you solve the problem?" (I used division to estimate how many boxes of tiles I would need.)

Activity 2

🕒 15 min

Multiplication or Division

Standards Alignments

Addressing 5.NF.B.6, 5.NF.B.7

The goal of this activity is to solve a variety of different problems, all of which can be solved by multiplying two fractions though the first problem may also be represented as division of a unit fraction by a whole number. The numbers are complex, making drawings an unlikely strategy to solve the problems. This encourages students to use their understanding of how to multiply fractions or divide with a whole number and a unit fraction. The synthesis focuses on why students chose multiplication or division to solve the problems.

♿ Access for Students with Disabilities

Engagement: Provide Access by Recruiting Interest. Leverage choice around perceived challenge. Invite students to select at least 2 out of the 3 to complete within the time allowed for the activity.
Supports accessibility for: Organization, Attention

Student-facing Task Statement

Solve each problem. Explain or show your reasoning.

1. If 11 grains of rice weigh $\frac{1}{3}$ gram, how much does each grain of rice weigh?
2. Mai's road is $\frac{9}{10}$ mile long. She ran $\frac{3}{4}$ of the length of her road. How far did she run?
3. If each tennis ball weighs $2\frac{1}{16}$ ounces, how much do 9 tennis balls weigh?

Student Responses

1. $\frac{1}{33}$ gram or equivalent. Sample response: If I cut a third into 11 equal pieces then there are 33 of those pieces in a whole.

Launch

- Groups of 2

Activity

- 6 minutes: independent work time
- 4 minutes: partner discussion
- Monitor for students who:
 - represent the situations with equations
 - explain how their equations represent each situation

Synthesis

- Ask previously selected students to share their solutions.

2. $\frac{27}{40}$ miles or equivalent. Sample response:

$$\frac{3}{4} \times \frac{9}{10} = \frac{27}{40}$$

3. $18\frac{9}{16}$ ounces or equivalent. Sample

response: $9 \times 2\frac{1}{16} = 18\frac{9}{16}$ since $9 \times 2 = 18$
and $9 \times \frac{1}{16} = \frac{9}{16}$.

• Display:

$$\frac{1}{3} \div 11 = \underline{\hspace{2cm}}$$

• "How does the equation represent the first situation?" (The 11 grains of rice together weigh $\frac{1}{3}$ gram so I need to divide $\frac{1}{3}$ by 11 to find out how many grams each grain weighs.)

• Display: $\frac{3}{4} \times \frac{9}{10} = \underline{\hspace{2cm}}$

• "How does the equation represent Mai's run?" (The $\frac{9}{10}$ is the full length of the road but she only ran $\frac{3}{4}$ of it so I multiply $\frac{9}{10}$ by $\frac{3}{4}$.)

Advancing Student Thinking

If students are not familiar with any of the contexts in the situations consider showing them pictures of rice or tennis balls or asking them to describe a landmark that is approximately a mile from the school.

Lesson Synthesis

🕒 10 min

Display problems from Number Talk:

$$5 \div \frac{1}{6} = 30$$

$$5 \times \frac{1}{6} = \frac{5}{6}$$

$$\frac{1}{5} \div 6 = \frac{1}{30}$$

$$\frac{1}{5} \times \frac{1}{6} = \frac{1}{30}$$

"What relationships do you see between these problems?" (There is a 5 and a 6 in each expression. Some of the equations have multiplication and some have division. Some have a whole number value and some have a fraction.)

"Describe one relationship to your partner."

"What do we know about the relationship between multiplication and division?" (I can sometimes find

the value of a division expression using multiplication.)

Record responses for all to see.

Suggested Centers

- Compare (1–5), Stage 8: Divide Fractions and Whole Numbers (Addressing)
- Rolling for Fractions (3–5), Stage 5: Divide Unit Fractions and Whole Numbers (Addressing)
- How Close? (1–5), Stage 6: Multiply to 3,000 (Supporting)

Complete Cool-Down

Response to Student Thinking

Students do not explain their reasoning.

Next Day Support

- Before the next lesson, have students work in pairs to pose questions in order to understand each other's explanations better.

Lesson 18: Represent Situations with Multiplication and Division

Standards Alignments

Addressing 5.NF.B, 5.NF.B.4, 5.NF.B.6, 5.NF.B.7

Teacher-facing Learning Goals

- Represent situations involving fractions with both multiplication and division equations.

Student-facing Learning Goals

- Let's represent problems with multiplication and division equations.

Lesson Purpose

The purpose of this lesson is for students to apply their understanding of fraction multiplication and division to solve problems in context.

In previous lessons, students multiplied fractions and divided whole numbers and unit fractions. They represented situations by drawing diagrams, writing expressions and equations, and they solved problems using numerical methods.

In this lesson, students continue to solve problems in context with a goal of understanding how to solve them using either multiplication or division. Students create and interpret diagrams, and explain how the same diagram can be interpreted as representing multiplication or division.

Access for:

Students with Disabilities

- Engagement (Activity 2)

English Learners

- MLR1 (Activity 1)

Instructional Routines

Number Talk (Warm-up)

Lesson Timeline

Warm-up	10 min
Activity 1	15 min

Teacher Reflection Question

Identify ways the math community you are working to foster is going well. What aspects would you like to work on? What actions can you take to improve those areas?

Activity 2	20 min
Lesson Synthesis	10 min
Cool-down	5 min

Cool-down (to be completed at the end of the lesson)

⌚ 5 min

Diagrams and Equations

Standards Alignments

Addressing 5.NF.B

Student-facing Task Statement

1.

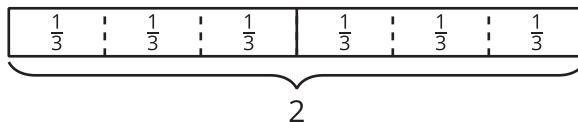

- Write a multiplication equation represented by the diagram. Explain or show your reasoning.
- Write a division equation represented by the diagram. Explain or show your reasoning.

Student Responses

- $6 \times \frac{1}{3} = 2$, the diagram shows 6 groups of $\frac{1}{3}$ and the total value is 2.
 - $2 \div \frac{1}{3} = 6$, the diagram shows that there are 6 groups of $\frac{1}{3}$ in 2.

----- **Begin Lesson** -----

Warm-up

⌚ 10 min

Number talk: Three and a Tenth

Standards Alignments

Addressing 5.NF.B.4, 5.NF.B.7

This Number Talk encourages students to think about multiplication and division involving a whole number and unit fraction. While the order of the factors does not matter for multiplication, as seen in the first two expressions, it does matter for division, as seen in the second pair of expressions. Monitor for students who find the value of the two division expressions using multiplication since the relationship between multiplication and division is the focus of this lesson.

Instructional Routines

Number Talk

Student-facing Task Statement

Find the value of each expression mentally.

- $3 \times \frac{1}{10}$
- $\frac{1}{10} \times 3$
- $\frac{1}{10} \div 3$
- $3 \div \frac{1}{10}$

Student Responses

- $\frac{3}{10}$, since it's 3 tenths.
- $\frac{3}{10}$, since it's the same as $3 \times \frac{1}{10}$.
- $\frac{1}{30}$, since it's $\frac{1}{3} \times \frac{1}{10}$.
- 30, since there are ten $\frac{1}{10}$ s in 1 and 3 times as many in 3.

Launch

- Display one expression.
- "Give me a signal when you have an answer and can explain how you got it."
- 1 minute: quiet think time

Activity

- Record answers and strategy.
- Keep expressions and work displayed.
- Repeat with each expression.

Synthesis

- "How did you find the value of $3 \div \frac{1}{10}$?" (I know that there are ten $\frac{1}{10}$ s in 1 so there are thirty $\frac{1}{10}$ s in 3.)

Activity 1

 15 min

Putting it All Together: Multiplication and Division

Standards Alignments

Addressing 5.NF.B.4, 5.NF.B.6, 5.NF.B.7

The purpose of this activity is for students to articulate the relationship between multiplication and division explaining how to solve two different problems using multiplication or division. Students have observed that dividing a whole number by a unit fraction gives the same result as multiplying the whole number by the denominator. They have also observed that dividing a unit fraction by a whole number gives the same result as multiplying the fraction by the unit fraction that has the whole number as a denominator. They also know from prior units and courses that the operations of multiplication and division are closely related. This activity brings these two ideas together, making explicit how one situation and one diagram modeling the situation can be interpreted using either multiplication or division (MP2).

Access for English Learners

MLR1 Stronger and Clearer Each Time. Before the whole-class discussion, give students time to meet with 2–3 partners to share and get feedback on their response to the problems about the neighborhood barbeque dinner. Invite listeners to ask questions, to press for details and to suggest mathematical language. Give students 2–3 minutes to revise their written explanation based on the feedback they receive.

Advances: Writing, Speaking, Listening

Student-facing Task Statement

1. Diego’s dad is making hamburgers for the picnic. There are 2 pounds of beef in the package. Each burger uses $\frac{1}{4}$ pound. How many burgers can be made with the beef in the package?
 - a. Draw a diagram to represent the situation.
 - b. Write a division equation to represent the situation.
 - c. Write a multiplication equation to represent the situation.
2. Diego and Clare are going to equally share $\frac{1}{4}$ pound of potato salad. How many pounds of potato salad will each person get?
 - a. Draw a diagram to represent the

Launch

- “We are going to solve some problems about a neighborhood barbecue dinner. What do you like to eat for dinner in the summertime?”

Activity

- 1–2 minutes: independent think time
- 4–5 minutes: partner work time

Synthesis

- Invite students to share their diagrams and equations for the first problem.
- “How does the diagram help you solve the problem?” (The number of burgers is the

situation.

- Write a division equation to represent the situation.
- Write a multiplication equation to represent the situation.

Student Responses

- Diego's dad can make 8 hamburgers.

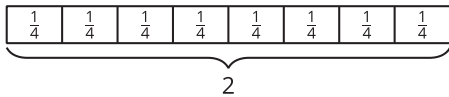

-
- $2 \div \frac{1}{4} = 8$
- $8 \times \frac{1}{4} = 2$

- Diego and Clare will each get $\frac{1}{8}$ pound of potato salad.

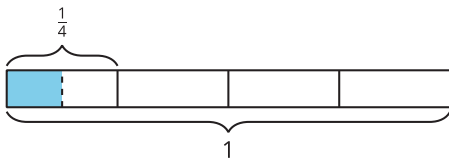

-
- $\frac{1}{4} \div 2 = \frac{1}{8}$
- $\frac{1}{2} \times \frac{1}{4} = \frac{1}{8}$

number of small rectangles or $\frac{1}{4}$ s.)

- “How does the diagram let you interpret the solution using multiplication?” (There are 8 burgers because $8 \times \frac{1}{4} = 2$.)
- “How does the diagram let you interpret the solution using division?” (It shows how many $\frac{1}{4}$ s there are in 2, 8.)

Activity 2

🕒 20 min

Multiplication or Division?

Standards Alignments

Addressing 5.NF.B.4, 5.NF.B.6, 5.NF.B.7

The purpose of this activity is to for students to make sense of situations, make an appropriate representation in the form of multiplication or division equations, and use that representation to answer questions about the situation (MP2). Students who have a strong understanding of the relationship between division and multiplication can reason about the situations using either

operation, though in some cases a representation as division goes beyond grade level which only addresses division of a whole number and a unit fraction. When partners share their work and discuss any disagreements they critique each other's reasoning (MP3).

Access for Students with Disabilities

Engagement: Develop Effort and Persistence. Invite students to generate a list of shared expectations for group work. Record responses on a display and keep visible during the activity.

Supports accessibility for: Attention, Organization

Student-facing Task Statement

For your set of problems:

- Write a multiplication or division expression for each situation.
- Answer the question and write an equation. Make sure to include appropriate units. Draw a diagram, if needed.
- Trade papers with your partner, and check your partner's equations. If you disagree, work to reach an agreement.

Partner A:

1. The distance from Han's house to Priya's house is $\frac{4}{5}$ kilometer. Han has walked $\frac{3}{4}$ of the way already. How many kilometers has he walked?
2. Clare's science class will test water samples in class. If there is a total of $\frac{1}{2}$ gallon of water and 10 groups, how much water will each group get if they split the water equally?
3. A container with 3 kilograms of strawberries is $\frac{1}{5}$ full. How many kilograms can the container hold?

Partner B:

1. It takes Han 4 minutes to walk $\frac{1}{3}$ kilometer.

Launch

- Groups of 2

Activity

- 6 minutes: independent work time
- 4 minutes: partner work time
- Monitor for students who:
 - Write multiple equations involving division and multiplication for the same problem.
 - Use diagrams to help them write expressions or equations.

Synthesis

- "How did you know what operation you needed to perform to find the answer?" (I drew a diagram to help me visualize the situation.)
- "For which problems was it difficult to tell what operation to use?" (I wasn't sure what to do with the strawberry problem.)
- For students who used a diagram, "How did drawing the diagram help you write an equation?" (It helped me see what operation could be used to solve the problem and see the result.)
- Point out equations that correctly represent the same problem (and are thus

How many minutes will it take him to walk 1 kilometer?

2. Clare's goal was to collect 4 kilograms of soil sample for her science project. She collected $2\frac{2}{3}$ times her goal. How many kilograms of soil did Clare collect?
3. A container that can hold a $\frac{1}{2}$ pound of strawberries is $\frac{3}{5}$ full. How many pounds of strawberries are in the container?

Student Responses

Partner A:

1. $\frac{12}{20}$ kilometer. Sample response: $\frac{3}{4} \times \frac{4}{5} = \frac{12}{20}$
2. $\frac{1}{20}$ gallon. Sample response: $\frac{1}{2} \div 10 = \frac{1}{20}$
3. 15 kilograms. Sample response: $3 \div \frac{1}{5} = 15$

Partner B:

1. 12 minutes. Sample response: $4 \div \frac{1}{3} = 12$
2. $10\frac{2}{3}$ kilograms. Sample response:
 $4 \times 2\frac{2}{3} = 4 \times 2 + 4 \times \frac{2}{3} = 8 + \frac{8}{3} = 8 + 2\frac{2}{3} = 10\frac{2}{3}$
3. $\frac{3}{10}$ pound. Sample response: $\frac{3}{5} \times \frac{1}{2} = \frac{3}{10}$

equivalent) but are expressed differently by displaying the problem about water and the equation: $\frac{1}{2} \div 10 = \frac{1}{20}$.

- "Many of you wrote a division equation to represent this problem. What multiplication equation can represent this problem?" ($10 \times \frac{1}{20} = \frac{1}{2}$)

Advancing Student Thinking

If students are not familiar with the measurement contexts in the situations, incorporate a launch that recalls the sizes of measurements such as kilograms, pounds, gallons, and kilometers. For example, describe a landmark that is 1 kilometer from the school or show students a container that has about $\frac{1}{2}$ pound of strawberries in it.

Lesson Synthesis

 10 min

"What do we know about the relationship between multiplication and division?" (I can often use multiplication to solve a division problem. To find $56 \div 4$ I need to find how many 4s there are in 56

and I can do that with multiplication, first taking 10 of them and then 4 more. Or to find $3 \div \frac{1}{8}$ I can say there are 8 $\frac{1}{8}$ s in each whole and then multiply that by 3.)

Create an anchor chart to record student thinking including examples and diagrams.

Suggested Centers

- Compare (1–5), Stage 8: Divide Fractions and Whole Numbers (Addressing)
- Rolling for Fractions (3–5), Stage 5: Divide Unit Fractions and Whole Numbers (Addressing)
- How Close? (1–5), Stage 6: Multiply to 3,000 (Supporting)

Complete Cool-Down

Response to Student Thinking

Students write a correct multiplication equation or a correct division equation but not both.

Next Day Support

- Before the next lesson, work with students to create a poster that shows how the diagram represents both division and multiplication.

Lesson 19: Fraction Games

Standards Alignments

Addressing 5.NF.B.4, 5.NF.B.6, 5.NF.B.7, 5.NF.B.7.c

Teacher-facing Learning Goals

- Multiply and divide with fractions.

Student-facing Learning Goals

- Let's multiply and divide with fractions.

Lesson Purpose

The purpose of this lesson is for students to use their understanding of fractions and division to make the largest and smallest expressions using given numbers.

Students work together with expressions involving a unit fraction divided by a whole number and a whole number divided by a unit fraction. In both activities, students write multiplication and division expressions, given specific digits to choose from. In Activity 1, students are applying what they learned to strategically write expressions that represent the greatest product or quotient. In Activity 2, they are trying to write expressions that represent the smallest product or quotient. This lesson has a Student Section Summary.

Access for:

Students with Disabilities

- Engagement (Activity 1)

English Learners

- MLR8 (Activity 1)

Instructional Routines

Estimation Exploration (Warm-up)

Lesson Timeline

Warm-up	10 min
Activity 1	20 min
Activity 2	15 min
Lesson Synthesis	10 min
Cool-down	5 min

Teacher Reflection Question

How effective were your questions in supporting students' thinking today? What did students say or do that showed they were effective?

Cool-down (to be completed at the end of the lesson)

⌚ 5 min

Fill in the Blanks

Standards Alignments

Addressing 5.NF.B.6, 5.NF.B.7

Student-facing Task Statement

Use the numbers 6, 7, 8, and 9 to make the greatest product. Show or explain how you know it is the greatest product.

$$\frac{\square}{\square} \times \frac{\square}{\square}$$

Student Responses

$\frac{9}{6} \times \frac{8}{7}$ or equivalent. It's the greatest because I used the two largest numbers for numerators and the two smallest numbers for denominators.

----- **Begin Lesson** -----**Warm-up**

⌚ 10 min

Estimation Exploration: Multiply Fractions

Standards Alignments

Addressing 5.NF.B.4

The purpose of this Estimation Exploration is for students to develop strategies for finding the product of a fraction and a mixed number. Since $2\frac{8}{9}$ is so close to 3, a good estimate is 3×28 or 84. Students may refine this estimate using the distributive property

$$8 \times 2\frac{8}{9} = 28 \times \left(3 - \frac{1}{9}\right)$$

$$= 28 \times 3 - 28 \times \frac{1}{9}$$

Since $\frac{28}{9}$ is about 3, $84 - 3$ or 81 is a very good estimate. Students will use these ideas in the lesson when they find products of fractions, whole numbers, and mixed numbers.

Instructional Routines

Estimation Exploration

Student-facing Task Statement

$$28 \times 2\frac{8}{9}$$

Record an estimate that is:

too low	about right	too high

Student Responses

Sample responses

- too low: 56 or less
- about right: 80–83
- too high: 84 or more

Launch

- Groups of 2
- Display the image.
- “What is an estimate that’s too high? Too low? About right?”

Activity

- 1 minute: quiet think time
- 1 minute: partner discussion
- Record responses.

Synthesis

- “How does $28 \times 2\frac{8}{9}$ compare to 28×2 ? How do you know?” (It’s larger because $2\frac{8}{9}$ is greater than 2.)
- “Why is 28×3 a good estimate?” (Because $2\frac{8}{9}$ is really close to 3.)
- “Is $28 \times 2\frac{8}{9}$ greater or less than 28×3 ? How do you know?” (Less because $2\frac{8}{9}$ is less than 3.)

Optional: Reveal the actual value, $80\frac{8}{9}$, and add it to the display.

Activity 1

 20 min

Largest Product or Quotient

Standards Alignments

Addressing 5.NF.B.6, 5.NF.B.7.c

The purpose of this activity is for students to apply what they have learned about multiplication and division of fractions to strategically write expressions with the greatest value. Students notice and explain patterns (MP7) such as:

- To make a product as large as possible, the two factors should be chosen as large as possible.
- To make a quotient or fraction as large as possible, the dividend should be as large as possible and the divisor as small as possible.

Access for English Learners

MLR8 Discussion Supports. Synthesis: Before inviting students to share their strategies for making the expression as large as possible, give groups time to rehearse what they might say if selected.
Advances: Speaking

Access for Students with Disabilities

Engagement: Provide Access by Recruiting Interest. Synthesis: Invite students to generate a list of additional examples of problems that can be solved using multiplication or division that connect to their personal backgrounds and interests.
Supports accessibility for: Attention, Conceptual Processing

Student-facing Task Statement

For each expression, work with your partner to decide what is the greatest product or quotient you can make with the numbers 1, 2, 3, 4, 5, and 6. For each expression, you can only use each number once. Explain or show your reasoning.

Launch

- Groups of 2

Activity

- 15 minutes: partner work time
- Monitor for students who reason about the size of the product or quotient based on the location of the digits.

$$1. \frac{\square}{\square} \times \frac{\square}{\square}$$

$$2. \square \div \frac{1}{\square}$$

$$3. \frac{1}{\square} \div \square$$

Student Responses

Sample responses:

- $\frac{6}{2} \times \frac{5}{1}$ or equivalent because I want the numerator to be as big as possible and this gets me 6×5 and I want the denominator to be as small as possible and this gets me 1×2 .
- $6 \div \frac{1}{5}$ or $5 \div \frac{1}{6}$ because I will take the dividend and multiply by the denominator so I want the biggest numbers there.
- $\frac{1}{1} \div 2$ or $\frac{1}{2} \div 1$ because the denominator of the quotient will be the product of the two numbers I put in so I want them to be as small as possible.

Synthesis

- Invite previously selected students to share their responses.
- Display the second expression.
- Invite students to share their strategies for making the expression as large as possible.
- “Why is $6 \div \frac{1}{5}$ a good choice for making this expression as large as possible?” (When I find the value I am multiplying 6 and 5. Those are the two biggest numbers so I know that will give me the biggest value.)
- “Is there another choice for filling in the blanks that gives the same value?” (Yes, I can also do $5 \div \frac{1}{6}$.)

Activity 2

🕒 15 min

Smallest Product or Quotient

Standards Alignments

Addressing 5.NF.B.6, 5.NF.B.7

In the previous activity, students chose digits to create expressions whose value was as large as

possible. The purpose of this activity is for students to create expressions with the smallest possible value. The expressions and digits that students use are the same so the patterns that they identified in the previous activity will apply here as well but they lead to a different choice of expressions.

Student-facing Task Statement

For each expression, work with your partner to decide what is the smallest product or quotient you can make with the numbers 1, 2, 3, 4, 5, and 6. You can only use each number once for each expression. Explain or show your reasoning.

$$1. \frac{\square}{\square} \times \frac{\square}{\square}$$

$$2. \frac{\square}{\square} \div \frac{1}{\square}$$

$$3. \frac{1}{\square} \div \square$$

Student Responses

Sample responses:

- $\frac{1}{6} \times \frac{2}{5}$ or equivalent because I am making the product of the numerators as small as possible and the product of the denominators as large as possible.
- $1 \div \frac{1}{2}$ or $2 \div \frac{1}{1}$ because I am making the dividend as small as possible and the divisor as large as possible.
- $\frac{1}{5} \div 6$ or $\frac{1}{6} \div 5$ because the denominator of the quotient will be the product of the two numbers I put in so I want them to be as large as possible.

Launch

- Groups of 2

Activity

- 7–8 minutes: independent work time
- 2–3 minutes: partner work time
- Monitor for students who reason about the size of the product or quotient based on the location of the digits.

Synthesis

- Display the last expression.
- “Why is $\frac{1}{6} \div 5$ a good choice for making the expression as small as possible?” (The numerator is 1 so I want the denominator to be as large as possible. That’s why putting in the 6 and 5 is a good strategy.)
- “Is there another choice for filling in the blanks that gives the same value?” (Yes, I can also do $\frac{1}{5} \div 6$.)
- “What is the value of $\frac{1}{6} \div 5$ and $\frac{1}{5} \div 6$? How do you know?” ($\frac{1}{30}$ because I am either cutting $\frac{1}{6}$ into 5 equal pieces or $\frac{1}{5}$ into 6 equal pieces. Either way there are 6×5 or 30 of those pieces in a whole.)

Lesson Synthesis

🕒 10 min

“Today we looked at the value of different multiplication and division expressions involving unit fractions.”

Display the first expressions from the two activities.

“What numbers will make the value of this expression as large as possible?” (I use the 5 and 6 for the numerators and the 1 and 2 for the denominators.)

“What numbers will make it as small as possible?” (I use the 1 and 2 for the numerators and the 5 and 6 for denominators.)

“How are the expressions we wrote for the largest and smallest values the same? How are they different?” (They use the same numbers but they are in the numerator in one expression and in the denominator in the other.)

Suggested Centers

- Compare (1–5), Stage 8: Divide Fractions and Whole Numbers (Addressing)
- Rolling for Fractions (3–5), Stage 5: Divide Unit Fractions and Whole Numbers (Addressing)
- How Close? (1–5), Stage 6: Multiply to 3,000 (Supporting)

✍ Student Section Summary

We used the relationship between multiplication and division to write both multiplication and division equations to represent the same situation. For example, there are 2 pounds of beef in the package. Each burger uses $\frac{1}{4}$ pound. How many burgers will the package make? We can write $2 \div \frac{1}{4} = 8$ and $8 \times \frac{1}{4} = 2$ to represent the situation.

We also wrote multiplication and division equations to represent the same diagram. For example:

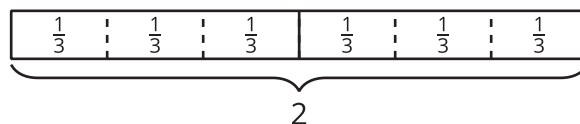

We can write $6 \times \frac{1}{3} = 2$ because the diagram shows 6 groups of $\frac{1}{3}$ and the total value is 2. We can also write $2 \div \frac{1}{3} = 6$ because the diagram shows that the number of groups of $\frac{1}{3}$ in 2 is 6.

----- Complete Cool-Down -----

Response to Student Thinking

Students do not write the largest possible product.

Next Day Support

- Before the warm-up, have students work in partners to discuss a correct response to this cool-down.

Lesson 20: How Much in the Group? (Optional)

Standards Alignments

Addressing 5.NF.B.7.b

Teacher-facing Learning Goals

- Represent and solve problems involving division of a whole number by a unit fraction.

Student-facing Learning Goals

- Let's solve more problems involving multiplication and division with fractions.

Lesson Purpose

The purpose of this lesson is for students to solve fraction division problems that ask: "How many in one group?"

In this optional lesson, students solve problems where a whole number quantity is a unit fraction of an unknown whole number. In these situations students may rely on their understanding of the relationship between multiplication and division. For example, if 8 ounces is $\frac{1}{4}$ of the amount of water in a bottle, students might represent this with a tape diagram:

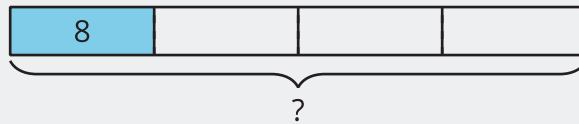

The tape diagram suggests the equation $8 = \frac{1}{4} \times ?$ which students will likely solve by seeing that $? = 4 \times 8$. The equation $8 = \frac{1}{4} \times ?$ can also be written using division with the equation $? \div 4 = 8$.

Access for:

Students with Disabilities

- Engagement (Activity 2)

English Learners

- MLR8 (Activity 1)

Instructional Routines

Estimation Exploration (Warm-up)

Lesson Timeline

Warm-up	10 min
Activity 1	20 min
Activity 2	10 min
Activity 3	10 min
Lesson Synthesis	10 min
Cool-down	5 min

Teacher Reflection Question

What do you love most about math? How are you sharing that joy with your students and encouraging them to think about what they love about math?

Cool-down (to be completed at the end of the lesson)

🕒 5 min

Drive to School

Standards Alignments

Addressing 5.NF.B.7.b

Student-facing Task Statement

- If $\frac{1}{3}$ of the drive to Han's school is 2 miles, how long is the whole drive to school? Draw a diagram and explain your reasoning.
 - Write a division equation that represents this situation.

Student Responses

- The drive is 6 miles. The diagram shows each $\frac{1}{3}$ of the drive is 2 miles, and that makes the whole drive 6 miles long since it's 3 groups of 2.

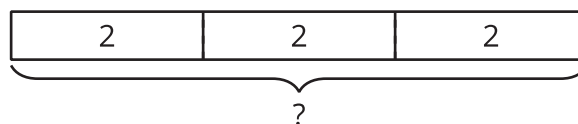

b. $2 \div \frac{1}{3} = 6$

----- **Begin Lesson** -----

Warm-up

🕒 10 min

Estimation Exploration: What Number Goes in the Blank?

Standards Alignments

Addressing 5.NF.B.7.b

The purpose of this Estimation Exploration is to estimate a whole given the value of a fraction of the whole. This prepares students for the type of problem they will solve in this lesson.

Instructional Routines

Estimation Exploration

Student-facing Task Statement

What number goes in the blank?

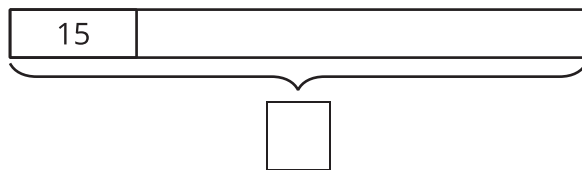

Record an estimate that is:

too low	about right	too high

Student Responses

Sample responses

- too low: 30–45
- about right: 60–75
- too high: 90–105

Launch

- Groups of 2
- Display the image.
- “What is an estimate that’s too high? Too low? About right?”
- 1 minute: quiet think time

Activity

- “Discuss your thinking with your partner.”
- 1 minute: partner discussion
- Record responses.

Synthesis

- “What strategies did you use to determine the number that goes in the blank?” (I tried to see how many 15’s fit in the whole rectangle.)

Activity 1

🕒 20 min

Different Equations

Standards Alignments

Addressing 5.NF.B.7.b

The purpose of this activity is to solve problems about how many students are in the whole fifth grade. Students should use whatever strategy makes sense to them. As students consider which equations represent the problem, they may use the context, the relationship between multiplication and division, or computations to make sense of the equations. When students interpret the meaning of their answer in a context, they are reasoning abstractly and quantitatively (MP2).

Access for English Learners

MLR8 Discussion Supports. Invite students to begin partner interactions by repeating the question, “How many students are in the class?” This gives both students an opportunity to produce language.

Advances: Conversing

Student-facing Task Statement

1. If $\frac{1}{3}$ of the class is 9 students, how many students are in the class?

Explain or show your reasoning.



2. Explain how each of these equations represents this situation.

a. $\frac{1}{3} \times \underline{\hspace{2cm}} = 9$

b. $\underline{\hspace{2cm}} \div 3 = 9$

c. $3 \times 9 = \underline{\hspace{2cm}}$

Student Responses

1. There are 27 students in the class. Sample response: $3 \times 9 = 27$

Launch

- Groups of 2

Activity

- 1–2 minutes: independent think time
- 6–8 minutes: partner work time
- Monitor for students who:
 - describe the total number of students as 27 because there are 3 groups of 9 students
 - describe the total number of students as 27 because when 27 is divided into 3 equal groups, there will be 9 in each group
 - describe the total number of students in the class as 27 because $\frac{1}{3} \times 27$ is 9

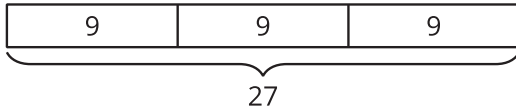

2. Sample responses:

- a. $\frac{1}{3} \times \underline{\quad} = 9$ represents the situation because $\frac{1}{3}$ of the class is 9. We know the size of each third of the class, but we don't know the total number of students in the class.
- b. $\underline{\quad} \div 3 = 9$ represents the situation because when the class is split into three equal groups there are 9 in each group.
- c. $3 \times 9 = \underline{\quad}$ represents the situation because if each third is 9, then 3 groups of 9 is the whole.

Synthesis

- Ask previously identified students to explain how each equation can represent the situation.
- Display:
 $27 \div 3 = 9$
 $3 \times 9 = 27$
- "What is the relationship between these two equations? Discuss with a partner." (They are like opposites. 27 divided into 3 equal groups is 9 and 3 groups of 9 is 27.)
- Display:
 $\frac{1}{3} \times 27 = 9$
- "How does this equation represent the situation?" (We know that $\frac{1}{3}$ of the class is 9, so the class must have 27 kids in it, because $\frac{1}{3}$ of 27 is 9.)

Activity 2

🕒 10 min

How Big is the Class?

Standards Alignments

Addressing 5.NF.B.7.b

The purpose of this activity is for students to reason about which equations represent a situation. They use their understanding of the relationship between multiplication and division to make their selections.

♿ Access for Students with Disabilities

Engagement: Provide Access by Recruiting Interest. Synthesis: Optimize meaning and value. Invite students to share equations with fractional values that would represent the total number of students in their classroom.

Supports accessibility for: Conceptual Processing, Attention

Student-facing Task Statement

1. Jada's class has 24 students in it. That is $\frac{1}{4}$ of the total students in the 5th grade. How many students are in the 5th grade? Explain or show your reasoning.
2. Select **all** the equations that represent this situation.

A. $\frac{1}{4} \times 24 = \underline{\hspace{2cm}}$

B. $\underline{\hspace{2cm}} \div 4 = 24$

C. $\frac{1}{4} \div 24 = \underline{\hspace{2cm}}$

D. $24 = \frac{1}{4} \times \underline{\hspace{2cm}}$

Student Responses

1. 96 students. $4 \times 24 = 96$
2. B, D

Launch

- Groups of 2

Activity

- 5–8 minutes: partner work time
- Monitor for students who use the relationship between multiplication and division to make their selections.

Synthesis

- Ask previously selected students to share their reasoning and solutions.
- Display:
 $\frac{1}{4} \div 24 = \underline{\hspace{2cm}}$
- "How do we know this equation does not represent the situation?" ($\frac{1}{4}$ divided into 24 groups is going to be really small. There will be $\frac{1}{96}$ in each group.)
- Display:
 $24 = \frac{1}{4} \times \underline{\hspace{2cm}}$
- "How does this equation represent the situation?" (We know there are 24 students in Jada's class and we know that is $\frac{1}{4}$ of the whole grade, but we don't know how many students are in the whole grade.)
- Display:
 $4 \times 24 = \underline{\hspace{2cm}}$
- "How does this equation help us figure out how many students are in the whole grade?" (If 24 is $\frac{1}{4}$ of the grade, we can multiply 24 by 4 to figure out how many are in the whole grade.)

Advancing Student Thinking

If students do not select appropriate equations, show these equations and ask them to explain how they are the same and different.

- $24 = \frac{1}{4} \times 96$
- _____ $\div 4 = 24$

Activity 3

🕒 10 min

How Many in One Group?

Standards Alignments

Addressing 5.NF.B.7.b

The purpose of this activity is for students to solve more “how many in one group” division problems in which the dividend is a whole number and the divisor is a unit fraction. The numbers are larger but still well-suited for a tape diagram representation. No method of solution is suggested or requested so students may draw a picture or a tape diagram or write an equation. For the second problem, the distance context may encourage students to use a number line representation to solve the problem.

Student-facing Task Statement

Solve each problem. Show or explain your reasoning.

1. 250 mg of calcium is $\frac{1}{4}$ of the daily recommended allowance. What is the daily recommended allowance of calcium? Show or explain your reasoning.
2. A rocket took 60 days to get $\frac{1}{5}$ of the way to Mars. How many days did it take the rocket to get to Mars? Show or explain your reasoning.

Student Responses

1. 1,000 mg. 250 is $\frac{1}{4}$ of the daily allowance so I

Launch

- Groups of 2
- 2 minutes: quiet think time

Activity

- 8 minutes: partner work time
- Monitor for students who use a tape diagram or number line to represent and solve each problem.

Synthesis

- Invite previously selected students to share their solutions.
- Display:

- need 4 times as much. $4 \times 250 = 1,000$
2. 300 days. Since 60 days is $\frac{1}{5}$ of the total time, I need 5 times as much. $5 \times 60 = 300$

$$60 = \frac{1}{5} \times \underline{\hspace{2cm}}$$

$$60 \div \frac{1}{5} = \underline{\hspace{2cm}}$$

- “These equations represent the rocket problem. We can solve both of these equations by multiplying 60 by 5. Why do we multiply by 5?” (60 days is $\frac{1}{5}$ of the trip, so 5×60 is the whole trip.)

Advancing Student Thinking

Students may not be familiar with the contexts in this task. Consider incorporating a launch into the activity that supports students’ understanding of the context, for example, an image of daily recommended nutritional values, or a video of a rocket launching into space.

Lesson Synthesis

 10 min

“Today we solved problems using the relationship between multiplication and division.”

Display: Jada’s class has 24 students in it. That is $\frac{1}{4}$ the total students in the 5th grade. How many students are in the whole grade?

“How did we use multiplication to solve this problem?” (We multiplied 24 by 4.)

Display equations:

- $\frac{1}{4} \times 96 = 96 \div 4$
- $24 \div \frac{1}{4} = 4 \times 24$

“Why are these equations true?” (If I divide 96 into 4 equal parts then each part is $\frac{1}{4}$ of 96. To find out how many $\frac{1}{4}$ s are in 24 I can multiply 24 by 4 since there are four $\frac{1}{4}$ s in each whole.)

Suggested Centers

- How Close? (1–5), Stage 6: Multiply to 3,000 (Addressing)
- Rolling for Fractions (3–5), Stage 5: Divide Unit Fractions and Whole Numbers (Addressing)

CKMath™
Core Knowledge **MATHEMATICS™**



Family Support
Materials

Family Support Materials

Multiplying and Dividing Fractions

In this unit, students use area concepts to represent and solve problems involving the multiplication of two fractions, and generalize that when they multiply two fractions, they need to multiply the two numerators and the two denominators to find their product. They also reason about the relationship between multiplication and division to divide a whole number by a unit fraction and a unit fraction by a whole number.

Section A: Fraction Multiplication

In this section, students build on their knowledge of fraction multiplication developed in the previous unit by using area concepts to understand the multiplication of a fraction times a fraction. Students draw diagrams to represent the fractional area. For example, students learn that the diagrams below can represent the situation “Kiran eats macaroni and cheese from a pan that is $\frac{1}{3}$ full. He eats $\frac{1}{4}$ of the remaining macaroni and cheese in the pan. How much of the whole pan did Kiran eat?”

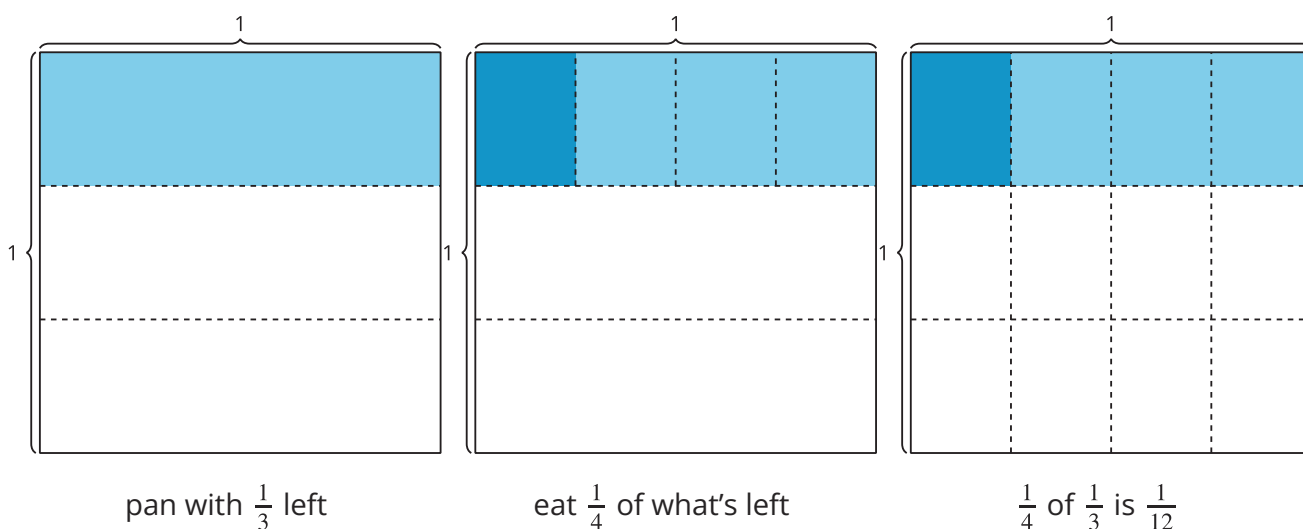

Students extend this conceptual understanding to multiply all types of fractions including fractions greater than 1 (for example, $\frac{7}{4}$). In each case, the students relate this multiplication to finding the area of a rectangle with fractions as side lengths. As the lessons progress, they notice that they can multiply the two numerators and the two denominators to find their product. This reasoning holds true for fractions greater than 1. For example,

$$\frac{3}{4} \times \frac{7}{5} = \frac{3 \times 7}{4 \times 5} = \frac{21}{20}.$$

Section B: Fraction Division

The section begins by using whole numbers to recall that the size of the quotient depends, for example, on the amount being shared and the number of people sharing. That is, each student will get more pretzels if 3 students share 45 pretzels than if 3 students share 24 pretzels. Similarly, each student will get fewer pretzels if 6 students share 24 pretzels than if 3 students share 24 pretzels.

This thinking helps students understand why dividing a whole number by a unit fraction results in a quotient that is larger than the whole number. For example, $2 \div \frac{1}{3} = 6$ because there are 6 groups of $\frac{1}{3}$ in 2. As students draw diagrams and write expressions involving the division of unit fractions, students recognize the relationship between multiplication and division. For example, they may notice that $2 \div \frac{1}{3} = 6$ because $6 \times \frac{1}{3} = 2$, and that $\frac{1}{5} \div 2 = \frac{1}{10}$ is related to $2 \times \frac{1}{10} = \frac{1}{5}$.

Section C: Problem Solving with Fractions

In this section, students apply what they have learned in the previous sections through problem solving. Students see how fraction multiplication and division are useful in different contexts. They use the meaning of multiplication and division to decide which operation to use to solve various problems. As students share strategies, they may realize that some problems could be solved using either division or multiplication.

Try it at home!

Near the end of the unit, ask your student to solve the following question:

A painter was painting a wall yellow. He painted $\frac{1}{3}$ of the wall yellow before being told he needed to paint the wall blue. At the end of the day, he was able to cover up $\frac{1}{5}$ of the yellow wall in blue. How much of the entire wall is blue?

Questions that may be helpful as they work:

- Can you draw a diagram to help you solve the problem?
- What equation would you use to solve the problem?
- Can you solve this using division or multiplication instead?

CKMath™
Core Knowledge **MATHEMATICS™**

Unit Assessments

Check Your Readiness A, B and C
End-of-Unit Assessment

Multiplying and Dividing Fractions: Section A Checkpoint

1. Write a multiplication expression that represents the area of the shaded region. Explain or show your reasoning.

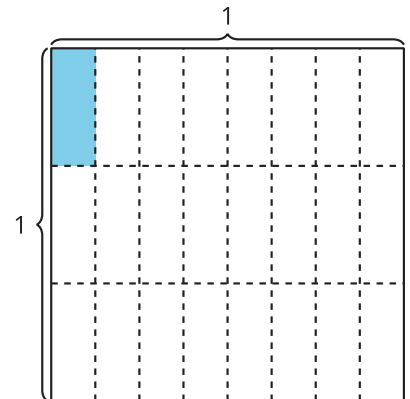

2. Find the value of each expression. Draw a diagram if needed.

a. $\frac{1}{4} \times \frac{1}{5}$

b. $\frac{2}{3} \times \frac{3}{4}$

c. $\frac{5}{4} \times \frac{5}{6}$

3. A rectangular garden is $2\frac{1}{2}$ meters wide and $4\frac{1}{2}$ meters long. What is the area of the garden? Explain or show your reasoning.

Multiplying and Dividing Fractions: Section B Checkpoint

1.

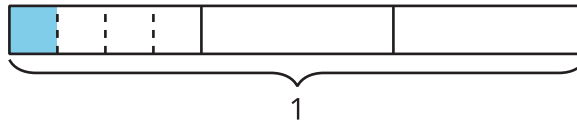

a. Write a division expression that represents the shaded piece of the diagram.

b. Write a multiplication expression that represents the shaded piece of the diagram.

2. Find the value of each expression. Draw a diagram if it helps.

a. $\frac{1}{3} \div 5$

b. $\frac{1}{6} \div 4$

c. $\frac{1}{8} \div 3$

3. There are 12 books on the top shelf of a book shelf. That is $\frac{1}{6}$ of the total number of books on the bookshelf. How many books are there on the bookshelf? Show or explain your reasoning.

Multiplying and Dividing Fractions: Section C Checkpoint

1. Three friends equally share $\frac{1}{2}$ kg of cherries.
 - a. Write a division expression that represents this situation.

 - b. Write a multiplication expression that represents this situation.

 - c. How many kilograms of cherries did each friend get? Explain or show your reasoning.

2. The trail is $3\frac{1}{4}$ miles long. Mai walked $\frac{1}{3}$ of the trail. How many miles did Mai walk? Explain or show your reasoning.

Multiplying and Dividing Fractions: End-of-Unit Assessment

1. Select all statements that are true about the diagram.

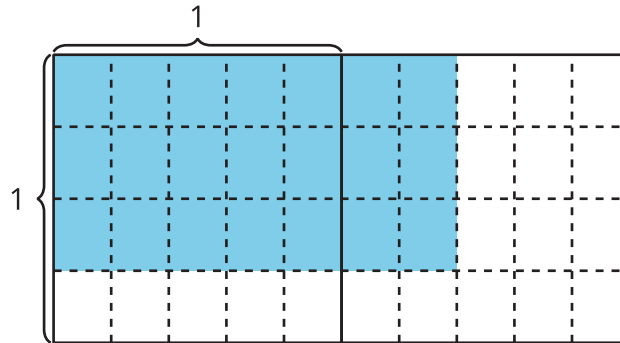

- A. The area of each small shaded piece is $\frac{1}{4} \times \frac{1}{5}$ square unit.
- B. The area of the shaded region is 21 square units.
- C. The area of the shaded region is $\frac{3}{4} \times \frac{7}{5}$ square units.
- D. The area of the shaded region is $\frac{20}{21}$ square units.
- E. The area of the shaded region is $\frac{21}{20}$ square units.

2. Select **all** expressions that represent the shaded region.

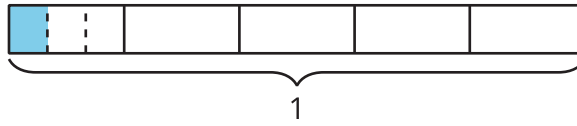

A. $\frac{1}{3} + \frac{1}{5}$

B. $\frac{1}{5} \div 3$

C. $\frac{1}{3} \times \frac{1}{5}$

D. $\frac{1}{3}$

E. $\frac{1}{7}$

3. Match each expression with its value.

A. $5 \div \frac{1}{3}$

B. $\frac{1}{3} \div 5$

C. $\frac{1}{30} \div 5$

D. $5 \div \frac{1}{30}$

1. $\frac{1}{150}$

2. $\frac{1}{15}$

3. 15

4. 150

4. 440 meters is $\frac{1}{4}$ of the way around the race track. How far is it around the whole race track? Explain or show your reasoning.

5. Find the value of each product.

a. $\frac{3}{12} \times \frac{2}{5}$

b. $\frac{8}{6} \times \frac{10}{11}$

c. $4 \times 6\frac{9}{10}$

d. $7\frac{3}{5} \times 4$

6. An apple weighs $\frac{1}{2}$ pound. Diego cuts the apple into 4 equal pieces. How many pounds does each piece of the apple weigh? Explain your reasoning.

7. A container holds $\frac{4}{5}$ liter of water. During a hike, Jada drank $\frac{2}{3}$ of the water. How much water did Jada drink? Explain your reasoning.

8. Each square tile on a bathroom floor measures $\frac{3}{2}$ feet by $\frac{3}{2}$ feet.

a. What is the area of each tile?

b. Mai says that the tiles have the same area as $\frac{3}{2}$ one-foot by one-foot tiles. Do you agree with Mai? Explain or show your reasoning.

c. The bathroom floor is covered by 12 of the $\frac{3}{2}$ feet by $\frac{3}{2}$ feet tiles. What is the area of the bathroom floor? Show or explain your reasoning.

CKMath™
Core Knowledge **MATHEMATICS™**

Assessment Answer Keys

Check Your Readiness A, B and C
End-of-Unit Assessment

Assessment Answer Keys

Assessment: Section A Checkpoint

Problem 1

Goals Assessed

- Represent and describe multiplication of a fraction by a fraction using area concepts.

Write a multiplication expression that represents the area of the shaded region. Explain or show your reasoning.

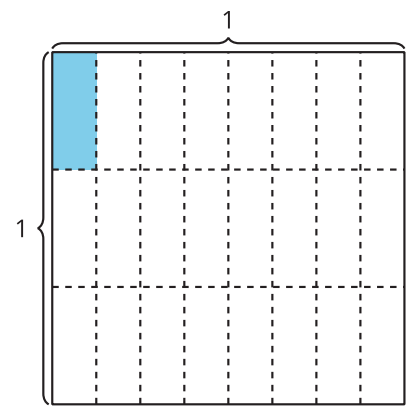

Solution

$\frac{1}{3} \times \frac{1}{8}$ or $\frac{1}{8} \times \frac{1}{3}$. Sample response: $\frac{1}{3}$ of $\frac{1}{8}$ of the square is shaded so that's $\frac{1}{3} \times \frac{1}{8}$.

Problem 2

Goals Assessed

- Recognize that $\frac{a}{b} \times \frac{c}{d} = \frac{a \times c}{b \times d}$ and use this generalization to multiply fractions numerically.

Find the value of each expression. Draw a diagram if needed.

- $\frac{1}{4} \times \frac{1}{5}$
- $\frac{2}{3} \times \frac{3}{4}$
- $\frac{5}{4} \times \frac{5}{6}$

Solution

a. $\frac{1}{20}$

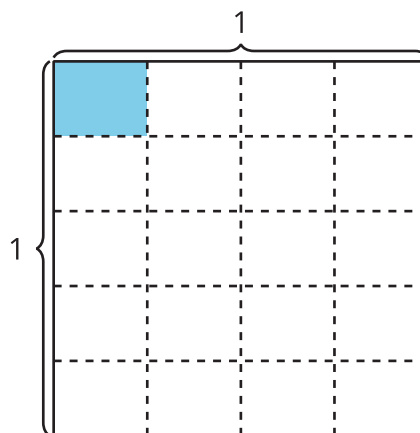

b. $\frac{6}{12}$ or $\frac{1}{2}$

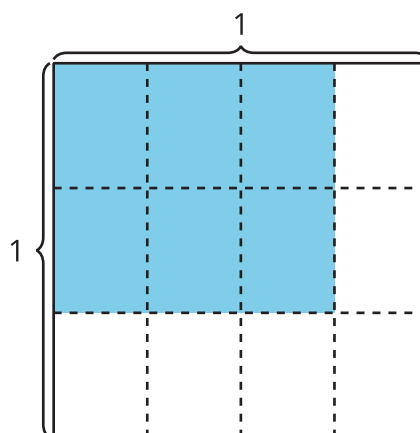

c. $\frac{25}{24}$ or $1\frac{1}{24}$

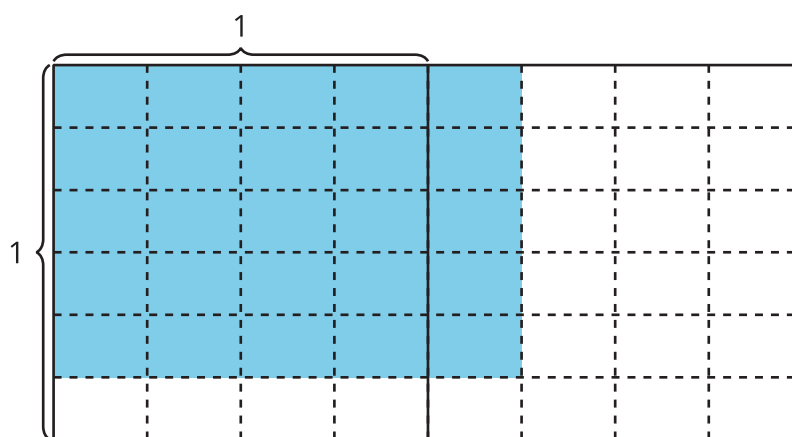

Problem 3

Goals Assessed

- Recognize that $\frac{a}{b} \times \frac{c}{d} = \frac{a \times c}{b \times d}$ and use this generalization to multiply fractions numerically.

A rectangular garden is $2\frac{1}{2}$ meters wide and $4\frac{1}{2}$ meters long. What is the area of the garden?
Explain or show your reasoning.

Solution

$11\frac{1}{4}$ square meters or equivalent.

Sample reasoning: $2 \times 2\frac{1}{2}$ is 5 so $4 \times 2\frac{1}{2} = 10$. Then $\frac{1}{2} \times 2 = 1$ and $\frac{1}{2} \times \frac{1}{2} = \frac{1}{4}$ so that's $10 + 1 + \frac{1}{4}$ or $11\frac{1}{4}$ square meters.

Assessment: Section B Checkpoint

Problem 1

Goals Assessed

- Divide a unit fraction by a whole number using whole-number division concepts.

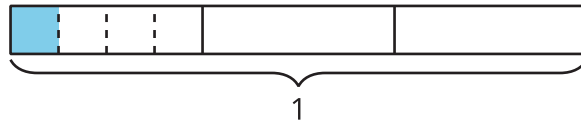

- Write a division expression that represents the shaded piece of the diagram.
- Write a multiplication expression that represents the shaded piece of the diagram.

Solution

- $\frac{1}{3} \div 4$
- $\frac{1}{4} \times \frac{1}{3}$

Problem 2

Goals Assessed

- Divide a whole number by a unit fraction using whole-number division concepts.

Find the value of each expression. Draw a diagram if it helps.

- $\frac{1}{3} \div 5$
- $\frac{1}{6} \div 4$
- $\frac{1}{8} \div 3$

Solution

a. $\frac{1}{15}$

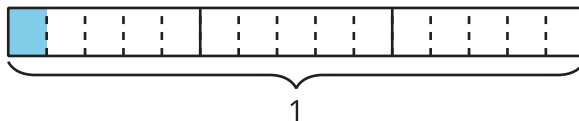

b. $\frac{1}{24}$

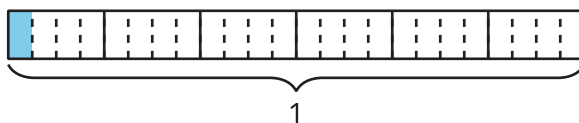

c. $\frac{1}{24}$

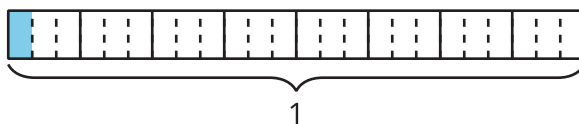

Problem 3

Goals Assessed

- Divide a whole number by a unit fraction using whole-number division concepts.

There are 12 books on the top shelf of a book shelf. That is $\frac{1}{6}$ of the total number of books on the bookshelf. How many books are there on the bookshelf? Show or explain your reasoning.

Solution

72 total books. Sample response: I multiplied 12 by 6 to get 72 and 12 is $\frac{1}{6} \times 72$.

Assessment: Section C Checkpoint

Problem 1

Goals Assessed

- Solve problems involving fraction multiplication and division.

Three friends equally share $\frac{1}{2}$ kg of cherries.

- Write a division expression that represents this situation.
- Write a multiplication expression that represents this situation.
- How many kilograms of cherries did each friend get? Explain or show your reasoning.

Solution

Sample responses:

- $\frac{1}{2} \div 3$
- $\frac{1}{3} \times \frac{1}{2}$
- $\frac{1}{6}$. I just found the product $\frac{1}{3} \times \frac{1}{2}$.

Problem 2

Goals Assessed

- Solve problems involving fraction multiplication and division.

The trail is $3\frac{1}{4}$ miles long. Mai walked $\frac{1}{3}$ of the trail. How many miles did Mai walk? Explain or show your reasoning.

Solution

$1\frac{1}{12}$ miles. Sample response: $\frac{1}{3}$ of 3 is 1 and $\frac{1}{3}$ of $\frac{1}{4}$ is $\frac{1}{3} \times \frac{1}{4}$ or $\frac{1}{12}$.

Assessment: End-of-Unit Assessment

Problem 1

Standards Alignments

Addressing 5.NF.B.4.b

Narrative

Students examine an area diagram showing a product of two non-unit fractions. Each true statement is essential to an understanding of the area model for finding a product of fractions.

- A explains why the denominator of a product of unit fractions can be taken as the product of their denominators.
- C interprets the area diagram as representing a product of fractions.
- E describes how to find the area.

Students may select B if they do not pay attention to the fact that the unit in the picture is a full square. They may select D if they are not careful about the numerator and denominator of the product.

Select **all** statements that are true about the diagram.

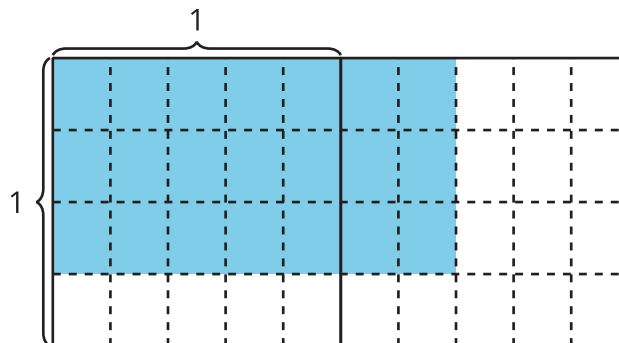

- A. The area of each small shaded piece is $\frac{1}{4} \times \frac{1}{5}$ square unit.
- B. The area of the shaded region is 21 square units.
- C. The area of the shaded region is $\frac{3}{4} \times \frac{7}{5}$ square units.
- D. The area of the shaded region is $\frac{20}{21}$ square units.

E. The area of the shaded region is $\frac{21}{20}$ square units.

Solution

["A", "C", "E"]

Problem 2

Standards Alignments

Addressing 5.NF.B.4.a, 5.NF.B.7.a, 5.OA.A.2

Narrative

Students identify expressions representing a tape diagram using both multiplication and division. Students may select A if they see the 5 equal parts in the whole and one of 3 equal parts shaded but apply the wrong operation to $\frac{1}{3}$ and $\frac{1}{5}$. They may select D if they see one of 3 equal parts shaded but do not identify the whole in the situation. They may select E if they see 7 parts, one of which is shaded, but do not identify that the parts are unequal.

Select **all** expressions that represent the shaded region.

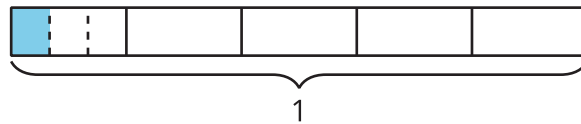

- A. $\frac{1}{3} + \frac{1}{5}$
- B. $\frac{1}{5} \div 3$
- C. $\frac{1}{3} \times \frac{1}{5}$
- D. $\frac{1}{3}$
- E. $\frac{1}{7}$

Solution

["B", "C"]

Problem 3**Standards Alignments**

Addressing 5.NF.B.7.a, 5.NF.B.7.b

Narrative

Students match quotients of a whole number and a unit fraction with their values. All of the expressions use the same digits so that students are encouraged to think about the value of the expression rather than just look for a particular digit appearing in the value. Students can choose the correct answers by listing the expressions and values in terms of increasing size rather than calculating the values.

Match each expression with its value.

A. $5 \div \frac{1}{3}$

B. $\frac{1}{3} \div 5$

C. $\frac{1}{30} \div 5$

D. $5 \div \frac{1}{30}$

1. $\frac{1}{150}$

2. $\frac{1}{15}$

3. 15

4. 150

Solution

- A: 3
- B: 2
- C: 1
- D: 4

Problem 4

Standards Alignments

Addressing 5.NF.B.7.b, 5.NF.B.7.c

Narrative

Students divide a whole number by a unit fraction in a “how many in one group” situation. To solve the problem, students may write an expression, $440 \div \frac{1}{4}$, or they might draw a tape diagram as shown in the solution, or they might use a number line.

Students may see 440 and the fraction $\frac{1}{4}$ and be tempted to multiply these two numbers and give an answer of 110. This would be how far it is around $\frac{1}{4}$ of a 440 meter race track.

440 meters is $\frac{1}{4}$ of the way around the race track. How far is it around the whole race track? Explain or show your reasoning.

Solution

1,760 meters. Sample response: the tape diagram shows 440 is $\frac{1}{4}$ of 1,760.

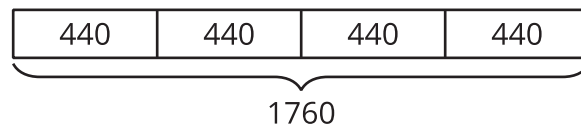

Problem 5

Standards Alignments

Addressing 5.NF.B.4

Narrative

Students find products of non-unit fractions and mixed numbers with no context. Students may make a drawing such as an area diagram, but this is not required and the complexity of the numbers makes this more challenging. Other items on the assessment dealing with area and tape diagrams assess students' ability to work with diagrams.

Find the value of each product.

a. $\frac{3}{12} \times \frac{2}{5}$

- b. $\frac{8}{6} \times \frac{10}{11}$
c. $4 \times 6\frac{9}{10}$
d. $7\frac{3}{5} \times 4$

Solution

- a. $\frac{6}{60}$ or equivalent
b. $\frac{80}{66}$ or equivalent
c. $27\frac{6}{10}$ or equivalent
d. $30\frac{2}{5}$ or equivalent

Problem 6

Standards Alignments

Addressing 5.NF.B.7.a, 5.NF.B.7.c

Narrative

This item complements the assessment problem about the distance around the track whose solution involved finding the value of a whole number divided by a unit fraction. This situation involves dividing a unit fraction by a whole number. Students may draw a number line or a tape diagram to support their reasoning.

An apple weighs $\frac{1}{2}$ pound. Diego cuts the apple into 4 equal pieces. How many pounds does each piece of the apple weigh? Explain your reasoning.

Solution

$\frac{1}{8}$
Sample response: If I divide each $\frac{1}{2}$ pound into 4 equal pieces I get 8 equal pieces total in a pound so each one is $\frac{1}{8}$ pound.

Problem 7

Standards Alignments

Addressing 5.NF.B.6

Narrative

Students find the product of non-unit fractions within a context. Students may use a drawing such as an area diagram as shown in the sample solution but this is not required. Students may forget to include the unit of liters with the response.

A container holds $\frac{4}{5}$ liter of water. During a hike, Jada drank $\frac{2}{3}$ of the water. How much water did Jada drink? Explain your reasoning.

Solution

$\frac{8}{15}$ liter or equivalent

Sample response: The square represents 1 liter of water and the shaded region represents $\frac{2}{3}$ of $\frac{4}{5}$ of a liter. The diagram shows that Jada drank $\frac{8}{15}$ of 1 liter.

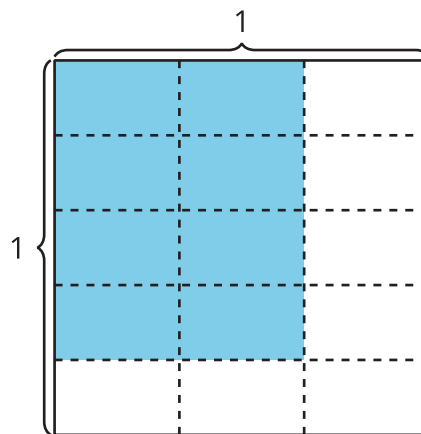

Problem 8

Standards Alignments

Addressing 5.NF.B.6

Narrative

Students solve a multi-step problem involving area. They need to first find the area of each square tile, most likely either by fraction multiplication or by drawing a diagram. Then they analyze a

common misconception, namely that when the side lengths of a square are multiplied by a factor the area of the square is also multiplied by that factor. Finally, they evaluate another product, this time of a fraction and a whole number. Note that the final answer for the area of the bathroom floor depends on the area of each tile and so student work here needs to be evaluated based on their answer for the area of each tile, assuming their solution method is to multiply that area by the number of tiles. In the same way, if students answer the second question incorrectly and then use this area to find the area of the bathroom floor, their work for the last question should be evaluated accordingly.

Each square tile on a bathroom floor measures $\frac{3}{2}$ feet by $\frac{3}{2}$ feet.

- What is the area of each tile?
- Mai says that the tiles have the same area as $\frac{3}{2}$ one-foot by one-foot tiles. Do you agree with Mai? Explain or show your reasoning.
- The bathroom floor is covered by 12 of the $\frac{3}{2}$ feet by $\frac{3}{2}$ feet tiles. What is the area of the bathroom floor? Show or explain your reasoning.

Solution

- Each tile has an area of $\frac{3}{2} \times \frac{3}{2}$ square feet or $\frac{9}{4}$ square feet.
- I disagree with Mai. Sample response: A one foot by one foot tile has area 1 square foot so $\frac{3}{2}$ of them have area $\frac{3}{2}$ square feet. That's less than $\frac{9}{4}$ square feet.
- $\frac{108}{4}$ square feet or 27 square feet. Sample response: There are 12 and each one has area $\frac{9}{4}$ square feet. That makes a total area of $12 \times \frac{9}{4}$ square feet. That's $\frac{108}{4}$ square feet or 27 square feet.

CKMath™
Core Knowledge **MATHEMATICS™**



Lesson
Cool Downs

Lesson 1: One Piece of One Part

Cool Down: Macaroni and Cheese

1. A pan of macaroni and cheese is $\frac{1}{2}$ full. Mai eats $\frac{1}{5}$ of the remaining macaroni and cheese in the pan.
 - a. Draw a diagram to represent the situation.

- b. How much of the whole pan did Mai eat? Explain or show your reasoning.

Lesson 2: Represent Unit Fraction Multiplication

Cool Down: How Much is Shaded?

Write a multiplication expression to represent the area of the shaded region.

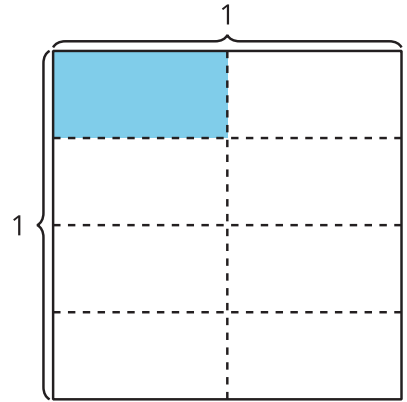

Lesson 3: Multiply Unit Fractions

Cool Down: Multiplication Equations

1. Write a multiplication equation to represent the shaded piece in the figure. Explain or show your reasoning.

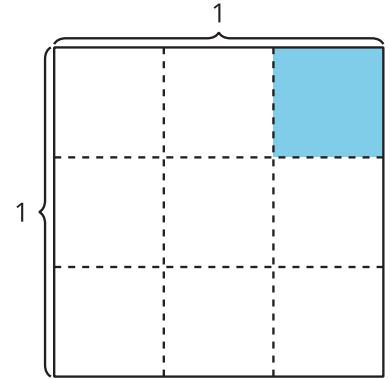

2. Complete each equation. Draw a diagram if it helps you.

a. $\frac{1}{5} \times \frac{1}{4} = \underline{\hspace{2cm}}$

b. $\frac{1}{2} \times \frac{1}{6} = \underline{\hspace{2cm}}$

Lesson 4: Situations about Multiplying Fractions

Cool Down: Area of the Park

1. Here is a diagram for a park.

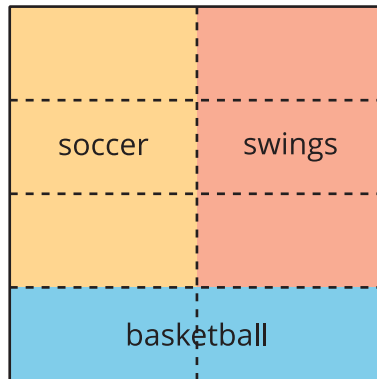

a. Write a multiplication expression to represent the fraction of the park that is for soccer.

b. How much of the whole park will be used for soccer?

Lesson 5: Multiply a Unit Fraction by a Non-unit Fraction

Cool Down: Write an Equation

Find the value of $\frac{1}{3} \times \frac{4}{5}$. Explain or show your reasoning. Use the diagram if it is helpful.

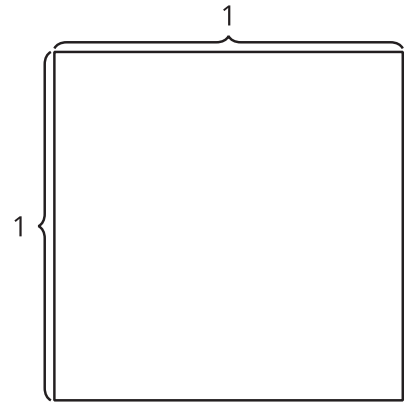

Lesson 6: Multiply Fractions

Cool Down: What is the Area?

- a. Write a multiplication expression to represent the area of the shaded region in square units.

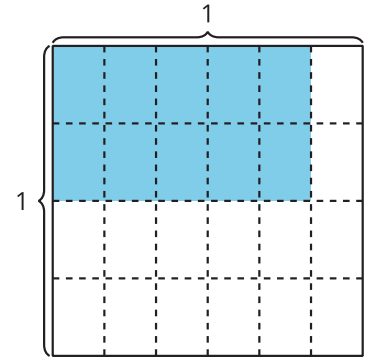

- b. What is the area of the shaded region in square units?

Lesson 7: Generalize Fraction Multiplication

Cool Down: Multiply Fractions

Find the value that makes each equation true.

1. $\frac{3}{4} \times \frac{10}{12} = \underline{\hspace{2cm}}$

2. $\frac{7}{5} \times \underline{\hspace{2cm}} = \frac{42}{15}$

Lesson 8: Apply Fraction Multiplication

Cool Down: The Flag of Chad

The area of this flag of Chad is $25\frac{1}{2}$ square centimeters. The blue, yellow, and red sections are all equal. What is the area of the blue part of the flag? Explain or show your reasoning.



Lesson 10: Concepts of Division

Cool Down: Reason About Division

1. What new idea did you have about division today?

2. What questions do you have about division with fractions?

Lesson 11: Divide Unit Fractions by Whole Numbers

Cool Down: Share Macaroni and Cheese

1. 6 people equally share $\frac{1}{2}$ a pan of macaroni and cheese.

a. Draw a diagram to represent the situation.

b. Write a division expression to represent the situation.

c. How much of the whole pan does each person get?

Lesson 12: Represent Division of Unit Fractions by Whole Numbers

Cool Down: Evaluate Division Expressions

1.

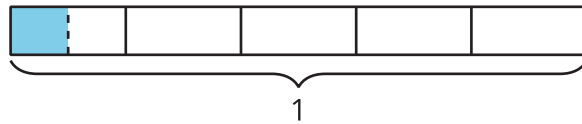

- Write a division expression for the shaded region. Explain or show your reasoning.
- What fraction does the shaded region represent? Explain or show your reasoning.

Lesson 13: Divide Whole Numbers by Unit Fractions

Cool Down: A Different Strip of Paper

Han has a strip of paper that is 3 feet long. He cuts it into pieces that are $\frac{1}{4}$ foot long. How many pieces are there? Explain or show your reasoning.

Lesson 15: Fraction Division Situations

Cool Down: Match and Solve

1. Match each expression to a situation. Answer each question.

○ $5 \div \frac{1}{4}$

○ $\frac{1}{4} \div 5$

a. Han cut 5 feet of ribbon into pieces that are $\frac{1}{4}$ foot long. How many pieces are there?

b. Han cut a $\frac{1}{4}$ foot long piece of ribbon into 5 equal pieces. How long is each piece?

Lesson 16: Reason About Quotients

Cool Down: Both Types of Problems

Which is greater, $5 \div \frac{1}{3}$ or $\frac{1}{3} \div 5$. Explain or show your reasoning.

Lesson 18: Represent Situations with Multiplication and Division

Cool Down: Diagrams and Equations

1.

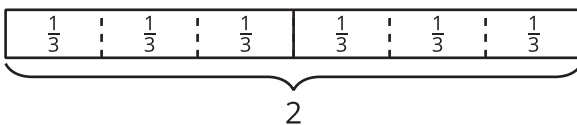

- Write a multiplication equation represented by the diagram. Explain or show your reasoning.

- Write a division equation represented by the diagram. Explain or show your reasoning.

Lesson 19: Fraction Games

Cool Down: Fill in the Blanks

Use the numbers 6, 7, 8, and 9 to make the greatest product. Show or explain how you know it is the greatest product.

$$\frac{\square}{\square} \times \frac{\square}{\square}$$

Lesson 20: How Much in the Group?

Cool Down: Drive to School

1. a. If $\frac{1}{3}$ of the drive to Han's school is 2 miles, how long is the whole drive to school?

Draw a diagram and explain your reasoning.

- b. Write a division equation that represents this situation.

CKMath™
Core Knowledge **MATHEMATICS™**

Instructional Masters

Instructional Masters for Multiplying and Dividing Fractions

address	title	students per copy	written on?	requires cutting?	card stock recommended?	color paper recommended?
Activity Grade5.3.15.1	Fraction Division Problem Sort	2	no	yes	no	no
Activity Grade5.3.17.1	Info Gap: Tiles	2	no	yes	no	no
Center	Rolling for Fractions Stage 2 Recording Sheet	1	yes	no	no	no
Center	Five in a Row Multiplication and Division Stage 4 Gameboard	2	no	no	no	no
Center	Rolling for Fractions Stage 4 Recording Sheet	1	yes	no	no	no
Center	How Close? Stage 7 Recording Sheet	1	yes	no	no	no
Center	Compare Stage 4 Division Cards	2	no	yes	no	no
Center	Compare Stage 3-8 Directions	2	yes	no	no	no
Center	Compare Stage 3-8 Directions	2	yes	no	no	no
Center	Compare Stage 8 Cards	2	no	yes	no	no
Center	Rolling for Fractions Stage 5 Recording Sheet	1	yes	no	no	no
Center	How Close? Stage 6 Recording Sheet	1	yes	no	no	no

Fraction Division Problem Sort

Fraction Division Problem Sort
A

$$3 \div \frac{1}{3}$$

Fraction Division Problem Sort
B

$$3 \div \frac{1}{4}$$

Fraction Division Problem Sort
C

$$4 \div \frac{1}{2}$$

Fraction Division Problem Sort
D

$$4 \div \frac{1}{3}$$

Fraction Division Problem Sort
E

Jada has 3 cups of granola. One serving of granola is $\frac{1}{3}$ cup. How many servings of granola does Jada have?

Fraction Division Problem Sort
F

Noah has 3 liters of orange juice. A serving of orange juice is $\frac{1}{4}$ liter. How many servings of orange juice does Noah have?

Fraction Division Problem Sort
G

Priya wants to run 4 miles. The track is $\frac{1}{2}$ mile long. How many times will she have to run around the track?

Fraction Division Problem Sort
H

Noah cut a 4 foot long ribbon into pieces that are $\frac{1}{3}$ foot long. How many pieces are there?

Fraction Division Problem Sort

Fraction Division Problem Sort
I

$$\frac{1}{3} \div 3$$

Fraction Division Problem Sort
M
Jada, Kiran, and Han share $\frac{1}{3}$ a pan of macaroni and cheese. How much macaroni and cheese does each person get?

Fraction Division Problem Sort
J

$$\frac{1}{4} \div 3$$

Fraction Division Problem Sort
N
Clare, Priya, and Mai share $\frac{1}{4}$ pound of granola. How much granola does each person get?

Fraction Division Problem Sort
K

$$\frac{1}{2} \div 4$$

Fraction Division Problem Sort
P
The track team runs a $\frac{1}{2}$ mile relay. There are 4 team members and they each run the same distance. How many miles does each person run?

Fraction Division Problem Sort
L

$$\frac{1}{3} \div 4$$

Fraction Division Problem Sort
Q
 $\frac{1}{4} \div 2$

Tiles
Problem Card 1

Elena is covering the floor with rectangular tiles.

How many tiles will Elena need to cover the floor?

Tiles
Data Card 1

- The floor is a square.
- The length of one side of the floor is 8 feet.
- One side of the tiles is $\frac{1}{3}$ foot.
- One side of the tiles is $\frac{1}{2}$ foot.
- The area of the floor is 64 square feet.

Tiles
Problem Card 2

Mai is covering part of the bathroom wall with rectangular tiles.



How many boxes of tiles does Mai need? How many tiles will she have left over?

Tiles
Data Card 2

- Each box has 42 tiles.
- The wall space is a rectangle that is 8 feet long and $6\frac{1}{2}$ feet wide.
- Each tile is 1 foot long and $\frac{1}{4}$ foot wide.
- Each box of tiles covers $10\frac{1}{2}$ square feet.

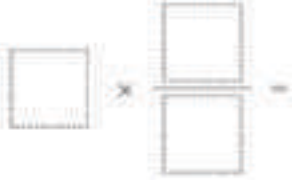
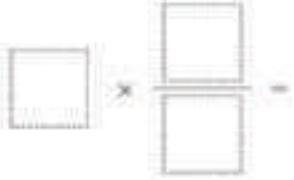
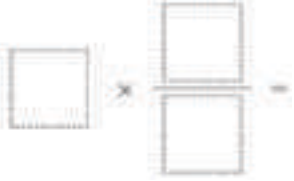
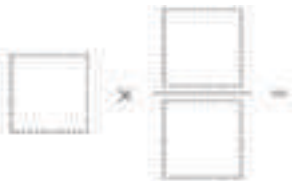

Rolling for Fractions Stage 2 Recording Sheet

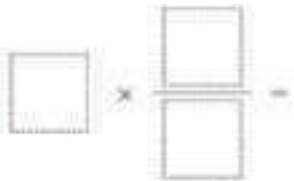
- Each partner:
 - Roll 3 number cubes. Use the numbers to complete the expression. Write the product.
 - Check your partner's work to make sure you agree.
 - Determine the number of points each partner gets:
 - 2 points for creating an expression less than 1
 - 5 points for creating an expression greater than 1
 - 10 points for creating an expression that is equal to 1
- Repeat for the next round. The partner who has the most points once the recording sheet is full wins the game.

round	equation	points
1		
2		
3		
4		
5		
6		

Rolling for Fractions Stage 2 Recording Sheet

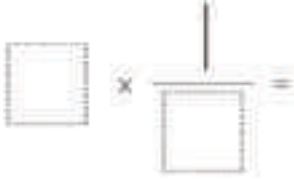
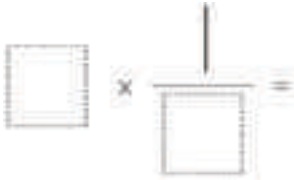
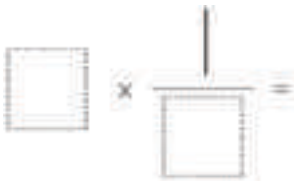
- Each partner:
 - Roll 3 number cubes. Use the numbers to complete the expression. Write the product.
 - Check your partner's work to make sure you agree.
 - Determine the number of points each partner gets:
 - 2 points for creating an expression less than 1
 - 5 points for creating an expression greater than 1
 - 10 points for creating an expression that is equal to 1
- Repeat for the next round. The partner who has the most points once the recording sheet is full wins the game.

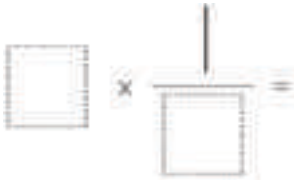
round	equation	points
1		
2		
3		
4		
5		
6		

Five in a Row Multiplication and Division Stage 4 Gameboard

Directions:

- Partner A:
 - Put a paper clip on 3 numbers in the grey row. Multiply the numbers. Cover the product of the numbers with a counter.
- Partner B:
 - Move 1 of the paper clips, multiply the numbers, and cover the product with a counter.
- Take turns. The first partner to cover 5 squares in a row wins.



36	2	125	20	24	6
8	80	10	12	15	16
30	4	5	25	27	18
32	1	40	45	48	50
64	9	100	3	20	24

1	2	3	4	5
---	---	---	---	---

Rolling for Fractions Stage 4 Recording Sheet

Each partner:

- Roll 4 number cubes. Use the numbers to complete the expression and write the product.
- Check your partner's work to make sure you agree.
- Determine the number of points each partner gets:
 - 5 points for the largest product
 - 3 points for the smallest product

Repeat for the next round. The partner who has the most points once the recording sheet is full wins the game.

round	equation	points
1	$\frac{\square}{\square} \times \frac{\square}{\square} =$	
2	$\frac{\square}{\square} \times \frac{\square}{\square} =$	
3	$\frac{\square}{\square} \times \frac{\square}{\square} =$	
4	$\frac{\square}{\square} \times \frac{\square}{\square} =$	
5	$\frac{\square}{\square} \times \frac{\square}{\square} =$	
6	$\frac{\square}{\square} \times \frac{\square}{\square} =$	

Rolling for Fractions Stage 4 Recording Sheet

Each partner:

- Roll 3 number cubes. Use the numbers to complete the expression and write the product.
- Check your partner's work to make sure you agree.
- Determine the number of points each partner gets:
 - 5 points for the largest product
 - 3 points for the smallest product

Repeat for the next round. The partner who has the most points once the recording sheet is full wins the game

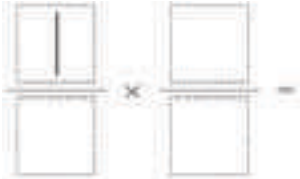
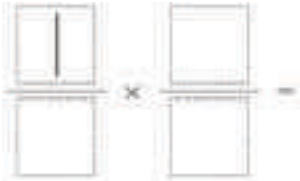
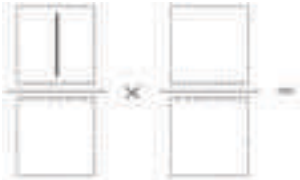
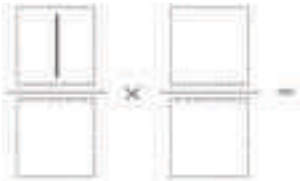
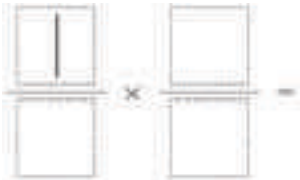
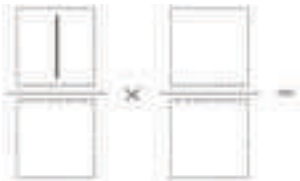
round	equation	points
1		
2		
3		
4		
5		
6		

How Close? Stage 7 Recording Sheet

Directions:

- Each partner:
 - Take 6 cards.
 - Choose 3 cards to make a multiplication expression.
 - Write an equation to show the product of the numbers you made.
 - Your score for each round is the difference between your product and 5.
- Take new cards so that you have 6 cards to start the next round.
- At the end of the game, add your score for each round. The player with the lowest score wins.

round	multiplication expression	points for the round
1	$\frac{\boxed{}}{\boxed{}} \times \boxed{} = \underline{\hspace{2cm}}$	
2	$\frac{\boxed{}}{\boxed{}} \times \boxed{} = \underline{\hspace{2cm}}$	
3	$\frac{\boxed{}}{\boxed{}} \times \boxed{} = \underline{\hspace{2cm}}$	
4	$\frac{\boxed{}}{\boxed{}} \times \boxed{} = \underline{\hspace{2cm}}$	

How Close? Stage 7 Recording Sheet

5	$\frac{\square}{\square} \times \square = \underline{\hspace{2cm}}$	
6	$\frac{\square}{\square} \times \square = \underline{\hspace{2cm}}$	
7	$\frac{\square}{\square} \times \square = \underline{\hspace{2cm}}$	
8	$\frac{\square}{\square} \times \square = \underline{\hspace{2cm}}$	

Compare Stage 4 Division Cards

Compare Stage 4

$$78 \div 6$$

Compare Stage 4

$$84 \div 7$$

Compare Stage 4

$$68 \div 4$$

Compare Stage 4

$$65 \div 5$$

Compare Stage 4

$$90 \div 6$$

Compare Stage 4

$$45 \div 15$$

Compare Stage 4

$$57 \div 19$$

Compare Stage 4

$$72 \div 18$$

Compare Stage 4 Division Cards

Compare Stage 4

$$52 \div 13$$

Compare Stage 4

$$84 \div 12$$

Compare Stage 4

$$42 \div 7$$

Compare Stage 4

$$56 \div 8$$

Compare Stage 4

$$72 \div 9$$

Compare Stage 4

$$64 \div 8$$

Compare Stage 4

$$81 \div 9$$

Compare Stage 4

$$72 \div 3$$

Compare Stage 4 Division Cards

Compare Stage 4

$$92 \div 4$$

Compare Stage 4

$$69 \div 3$$

Compare Stage 4

$$84 \div 4$$

Compare Stage 4

$$63 \div 3$$

Compare Stage 3-8 Directions

Directions:

- Split the deck between the players.
- Each player turns over a card.
- Compare the values. The player with the greater value keeps both cards.
- If the values are the same, each player turns over one more card. The player with the greater value keeps all four cards.
- Play until you run out of cards. The player with the most cards at the end of the game wins.

Record any sets of cards that are challenging to compare:

Compare Stage 3-8 Directions

Directions:

- Split the deck between the players.
- Each player turns over a card.
- Compare the values. The player with the greater value keeps both cards.
- If the values are the same, each player turns over one more card. The player with the greater value keeps all four cards.
- Play until you run out of cards. The player with the most cards at the end of the game wins.

Record any sets of cards that are challenging to compare:

Compare Stage 8 Cards

Compare Stage 8

$$\frac{1}{3} \div 9$$

Compare Stage 8

$$3 \times 12 \div 2$$

Compare Stage 8

$$2 \times \frac{1}{3} \times 9$$

Compare Stage 8

$$\frac{2}{4} \times 12$$

Compare Stage 8

$$\frac{2}{3} \times 6 \times 3$$

Compare Stage 8

$$\frac{3}{4} \times 2 \times 6$$

Compare Stage 8

$$\left(\frac{2}{3} \times 11\right) + 12$$

Compare Stage 8

$$\frac{3}{2} \times 12$$

Compare Stage 8 Cards

Compare Stage 8

$$4 \times \frac{1}{2} \times 12$$

Compare Stage 8

$$(3 \times 12) \div 3$$

Compare Stage 8

$$3 \times 10 \times \frac{1}{2}$$

Compare Stage 8

$$\frac{6}{2} \times 12$$

Compare Stage 8

$$12 \times 3 \times \frac{3}{2}$$

Compare Stage 8

$$\left(\frac{3}{2} \times 10\right) + 6$$

Compare Stage 8

$$5 \times \frac{1}{8} \times \frac{1}{3}$$

Compare Stage 8

$$\frac{5}{8} \times \frac{1}{4}$$

Compare Stage 8 Cards

Compare Stage 8

$$\frac{4}{8} \times \frac{1}{2}$$

Compare Stage 8

$$\frac{4}{8} \times \frac{1}{4} + \frac{1}{4}$$

Compare Stage 8

$$\frac{2}{8} \times \frac{5}{4}$$

Compare Stage 8

$$\frac{5}{9} \times \frac{1}{5}$$

Compare Stage 8

$$\frac{3}{5} \times \frac{4}{6}$$

Compare Stage 8

$$\frac{4}{5} \times \frac{5}{6}$$

Compare Stage 8

$$4 \times \frac{1}{6} \times \frac{3}{5}$$

Compare Stage 8

$$3 \times \frac{1}{6} \times 4$$

Compare Stage 8 Cards

Compare Stage 8

$$12 \div \frac{1}{3}$$

Compare Stage 8

$$12 \div \frac{1}{5}$$

Compare Stage 8

$$\frac{1}{4} \div 12$$

Compare Stage 8

$$10 \div \frac{1}{4}$$

Compare Stage 8

$$\frac{1}{6} \div 5 + 2$$

Compare Stage 8

$$\frac{1}{7} \div 4$$

Compare Stage 8

Compare Stage 8

Rolling for Fractions Stage 5 Recording Sheet

Each partner:

- Roll 3 number cubes. Use the numbers to create a division expression with a whole number and a fraction.
- Write the equation to represent the quotient
- Check your partner’s work to make sure you agree.
- Determine the number of points each partner gets:
 - 5 points for the largest quotient
 - 3 points for the smallest quotient

Repeat for the next round. The partner who has the most points once the recording sheet is full wins the game.

round	equation	points
1		
2		
3		
4		
5		
6		

How Close? Stage 6 Recording Sheet

Directions:

- Each partner:
 - Take 6 cards.
 - Choose 4 cards to make a multiplication expression. You can multiply a one-digit number by a three-digit number or a two-digit number by a two-digit number.
 - Write an equation to show the product of the numbers you made.
 - Your score for each round is the difference between your product and 3,000.
- Take new cards so that you have 6 cards to start the next round.
- At the end of the game, add your score for each round. The player with the lowest score wins.

round	multiplication equation	points for the round
1		
2		
3		
4		
5		
6		
7		
8		

Credits

CKMath K–8 was originally developed by Open Up Resources and authored by Illustrative Mathematics, <https://www.illustrativemathematics.org>, and is copyrighted as 2017–2019 by Open Up Resources. It is licensed under the Creative Commons Attribution 4.0 International License (CC BY 4.0). The Open Up Resources K–8 Math Curriculum is available at: <https://www.openupresources.org/math-curriculum/>.

Adaptations and updates to the IM K–8 Math English language learner supports are copyright 2019 by Open Up Resources and licensed under the Creative Commons Attribution 4.0 International License (CC BY 4.0),

Adaptations and updates to IM K–8 Math are copyright 2019 by Illustrative Mathematics, including the additional English assessments marked as "B", and the Spanish translation of assessments marked as "B". These adaptations and updates are licensed under the Creative Commons Attribution 4.0 International License (CC BY 4.0).

This particular work is based on additional work of the Core Knowledge® Foundation (www.coreknowledge.org) made available through licensing under a Creative Commons Attribution-NonCommercial-ShareAlike 4.0 International License.

Illustration and Photo Credits

Artisticco LLC / Alamy Stock Vector: Cover B

Illustrative Math K–8 / Cover Image, all interior illustrations, diagrams, and pictures / Copyright 2019 / Licensed under the Creative Commons Attribution 4.0 International License (CC BY 4.0).

These materials include public domain images or openly licensed images that are copyrighted by their respective owners, unless otherwise noted/credited. Openly licensed images remain under the terms of their respective licenses.



CKMath™
Core Knowledge **MATHEMATICS™**

CKMath™
Core Knowledge **MATHEMATICS™**

A comprehensive program for mathematical skills and concepts
as specified in the **Core Knowledge Sequence**
(content and skill guidelines for Grades K–8).

Core Knowledge MATHEMATICS™
units at this level include:

Finding Volume
Fractions as Quotients and Fraction Multiplication
Multiplying and Dividing Fractions
Wrapping Up Multiplication and Division
with Multi-Digit Numbers
Place Value Patterns and Decimal Operations
More Decimal and Fraction Operations
Shapes on the Coordinate Plane
Putting it All Together

www.coreknowledge.org

Core Knowledge Curriculum Series™