



Core Knowledge[®] MATHEMATICS

Finding Volume



Student Workbook



Creative Commons Licensing

This work is licensed under a Creative Commons Attribution-NonCommercial-ShareAlike 4.0 International License.



You are free:

- to Share**—to copy, distribute, and transmit the work
- to Remix**—to adapt the work

Under the following conditions:

Attribution—You must attribute the work in the following manner:

CKMath 6–8 was originally developed by Open Up Resources and authored by Illustrative Mathematics, <https://www.illustrativemathematics.org>, and is copyrighted as 2017–2019 by Open Up Resources. It is licensed under the Creative Commons Attribution 4.0 International License (CC BY 4.0). The Open Up Resources 6–8 Math Curriculum is available at: <https://www.openupresources.org/math-curriculum/>.

Adaptations and updates to the IM 6–8 Math English language learner supports and the additional English assessments marked as "B" are copyright 2019 by Open Up Resources and licensed under the Creative Commons Attribution 4.0 International License (CC BY 4.0).

Adaptations and updates to the IM K–8 Math Spanish translation of assessments marked as "B" are copyright 2019 by Illustrative Mathematics. These adaptations and updates are licensed under the Creative Commons Attribution 4.0 International License (CC BY 4.0).

This particular work is based on additional work of the Core Knowledge® Foundation (www.coreknowledge.org) made available through licensing under a Creative Commons Attribution-Non Commercial-Share Alike 4.0 International License. This does not in any way imply that the Core Knowledge Foundation endorses this work.

Noncommercial—You may not use this work for commercial purposes.

Share Alike—If you alter, transform, or build upon this work, you may distribute the resulting work only under the same or similar license to this one.

With the understanding that:

For any reuse or distribution, you must make clear to others the license terms of this work. The best way to do this is with a link to this web page:

<https://creativecommons.org/licenses/by-nc-sa/4.0/>

Copyright © 2023 Core Knowledge Foundation
www.coreknowledge.org

All Rights Reserved.

Core Knowledge®, Core Knowledge Curriculum Series™, Core Knowledge Math™ and CKMath™ are trademarks of the Core Knowledge Foundation.

Trademarks and trade names are shown in this book strictly for illustrative and educational purposes and are the property of their respective owners. References herein should not be regarded as affecting the validity of said trademarks and trade names.

Finding Volume

Table of Contents

Lesson 1	What is Volume?	1
Lesson 2	Measure Volume	4
Lesson 3	Volumes of Prism Drawings	7
Lesson 4	Use Layers to Determine Volume	10
Lesson 5	Side Lengths of Rectangular Prisms	16
Lesson 6	Expressions for Volume	20
Lesson 7	Cubic Units of Measure	25
Lesson 8	Figures Made of Prisms	30
Lesson 9	Measure Figures Made From Prisms	33
Lesson 10	Represent Volume with Expressions	36
Lesson 11	All Kinds of Prisms	40
Lesson 12	Lots and Lots of Garbage (optional)	44
Cumulative Practice Problems		
Section A:	Unit Cubes and Volume	48
Section B:	Expressions for Finding Volume	55
Section C:	Volume of Solid Figures	59



Finding Volume
Student Workbook
Core Knowledge Mathematics™

Lesson 1: What Is Volume?

- Let's build and compare objects made of cubes.

Warm-up: Which One Doesn't Belong: Objects Made of Cubes

Which one doesn't belong?

A

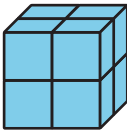

B

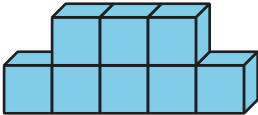

C

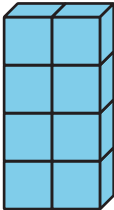

D

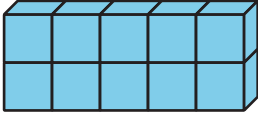

1.1: Build Objects with Cubes

1. Which is bigger? Explain or show your reasoning.

A

B

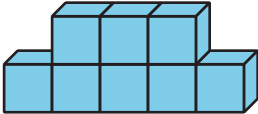
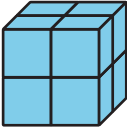

2. Which is bigger? Explain or show your reasoning.

A

B

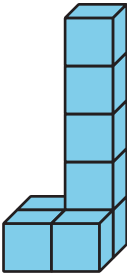
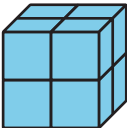

3. What does it mean for an object to be "bigger"?

1.2: Build and Order

1. Each group member:
 - a. Take a handful of connecting cubes.

 - b. Build an object.

2. Order the objects by volume.

3. Repeat.

4. Each group member:
 - a. Take 9 connecting cubes.

 - b. Build an object.

5. Order the objects by volume



Lesson 2: Measure Volume

- Let's count cubes.

Warm-up: Which One Doesn't Belong: Cubes

Which one doesn't belong?

A

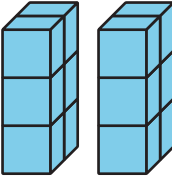

B

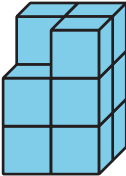

C

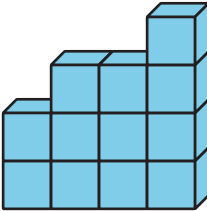

D

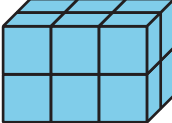

2.1: Finding Volume

1. Partner A: Build an object using 8–12 cubes and give the object to Partner B.
2. Partner B: Explain how you would count the number of cubes in the object.
3. Partner A: Explain if you would count the cubes in the same way or in a different way.
4. Switch roles and repeat.
5. Which objects were easiest to count? Why?



2.2: Guess My Prism

What is the same? What is different?

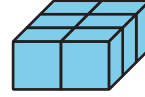
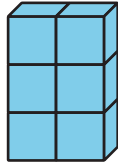

1. The goal of the game is to get your partner to build the same prism.
 - Partner A: Use 16–24 cubes to build a prism. Describe it to your partner.
 - Partner B: Build the prism your partner describes to you.
2. Place the two prisms next to each other and discuss what is the same and what is different about them.
3. Switch roles and repeat.

Lesson 3: Volumes of Prism Drawings

- Let's use layers to find volume.

Warm-up: Number Talk: Multiplication

Find the value of each expression mentally.

- 6×4

- $3 \times 2 \times 4$

- $3 \times 2 \times 5$

- $3 \times 2 \times 6$



3.1: Build Rectangular Prisms

The prisms on the cards are completely packed with unit cubes.

1. Pick a card.
2. Build the rectangular prism.
3. Find the volume. Explain how you found the volume to your partner.
4. Repeat.



3.2: Layers, layers, and more layers

The prisms are completely packed with unit cubes. Determine the volume of each prism. Explain or show your reasoning.

1.

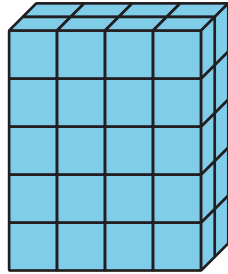

2.

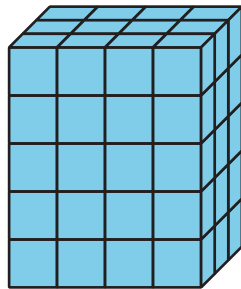

3.

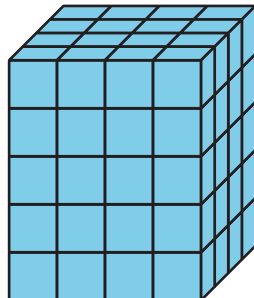

Lesson 4: Use Layers to Determine Volume

- Let's relate multiplication to how we use layers to find volume.

Warm-up: Estimation Exploration: How Many Cubes?



About how many cubes were used to build this prism?

Record an estimate that is:

too low	about right	too high

4.1: Layers in Rectangular Prisms

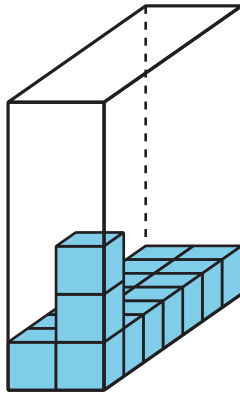

1. Complete the table. Be prepared to explain your reasoning.

prism	number of cubes in one layer	number of layers	volume
A			
B			
C			
D			

Prism A

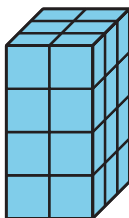

Prism B

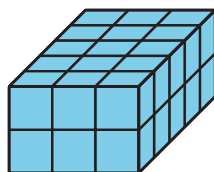

Prism C

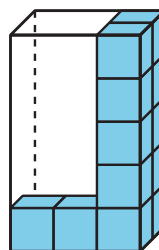

Prism D

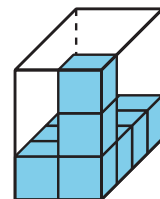

2. Find the volume of each prism. Explain or show your reasoning.

Prism E

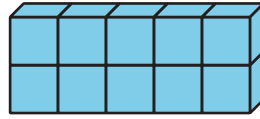

Prism F

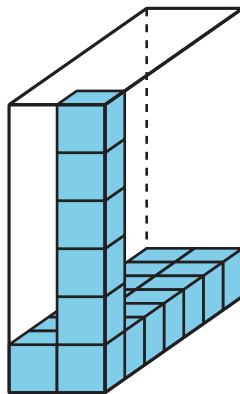

3. How can you find the volume of any rectangular prism?

4.2: Finding Volume in Different Ways

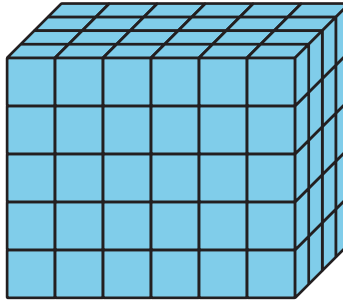

1. Explain or show how the expression 5×24 represents the volume of this rectangular prism.

2. Explain or show how the expression 6×20 represents the volume of this rectangular prism.

3. Find a different way to calculate the volume of this rectangular prism. Explain or show your thinking.

4. Write an expression to represent the way you calculated the volume.

Section Summary

Section Summary

We call the amount of space an object takes up **volume**. This prism has a volume of 120 cubes.

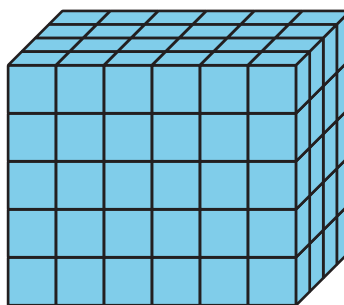

To find the volume of any prism, we can find the number of cubes in one layer and multiply that number by the number of layers. We can describe this prism as having 6 layers of 20 cubes, 4 layers of 30 cubes, or 5 layers of 24 cubes. We can use all of these expressions to represent the volume of the prism:

$$5 \times 24, 5 \times (6 \times 4)$$

$$6 \times 20, 6 \times (5 \times 4)$$

$$4 \times 30, 4 \times (5 \times 6)$$

Lesson 5: Side Lengths of Rectangular Prisms

- Let's describe the side lengths of a prism and find the volume.

Warm-up: Notice and Wonder: Prism Print

What do you notice? What do you wonder?

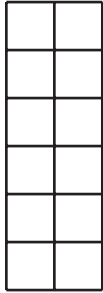
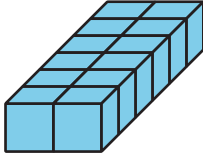
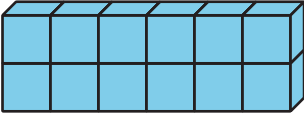
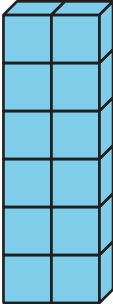

5.1: All About That Base

Here are 3 rectangular prisms.

1

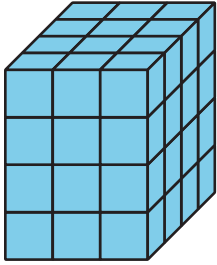

2

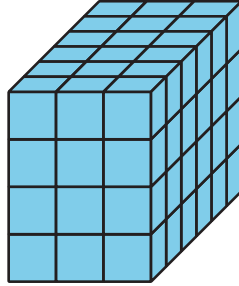

3

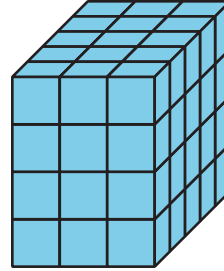

These rectangles represent bases of the prisms.

A

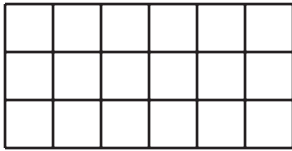

B

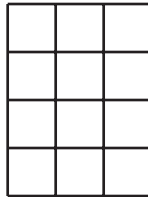

C

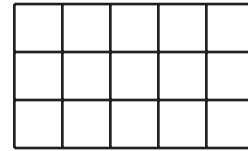

1. Match each prism with a rectangle that represents its base. Note: Some prisms may match more than 1 rectangular base.
2. Find the volume of each prism. Explain or show your reasoning.

5.2: Growing Prism

Here is a base of a rectangular prism.

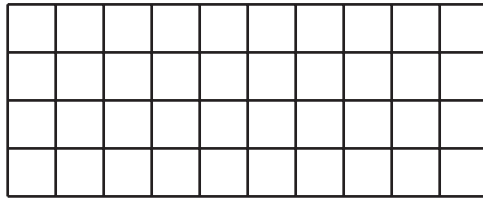

1. Fill out the table for the volumes of rectangular prisms with this base and different heights.

height	multiplication expression to represent the volume	volume
1		
2		
3		
10		
25		

5.3: What is the Question?

This is the base of a rectangular prism that has a height of 5 cubes.

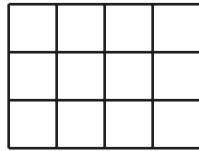

These are answers to questions about the prism. Read each answer and determine what question it is answering about the prism.

1. 3 is the answer. What is the question?

2. 5 is the answer. What is the question?

3. $3 \times 4 = 12$. The answer is 12. What is the question?

4. $12 \times 5 = 60$. The answer is 60 cubes. What is the question?

5. 3 by 4 by 5 is the answer. What is the question?

Lesson 6: Expressions for Volume

- Let's write expressions for the volume of rectangular prisms.

Warm-up: True or False: Parentheses or No Parentheses

Decide if each statement is true or false. Be prepared to explain your reasoning.

- $(4 \times 2) \times 5 = 4 \times (2 \times 5)$

- $(2 \times 5) \times 4 = 2 \times 20$

- $5 \times 4 \times 2 = 10 \times 40$

6.1: Card Sort: Match the Expression

1. Match each rectangular prism with the expression(s) that represents its volume in cubic units. Be prepared to explain your reasoning.
2. For each prism write one additional expression, not in the card sort, that represents its volume in cubic units.



6.2: A Tale of Two Tables

1. Work with your partner to complete the tables. One partner completes Table 1 and the other completes Table 2.

Prism A

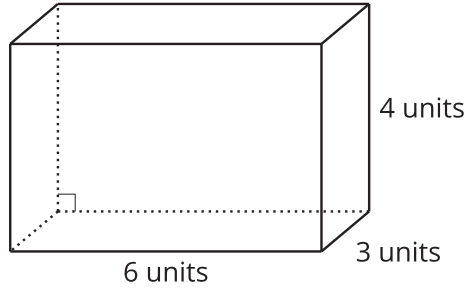

Prism B

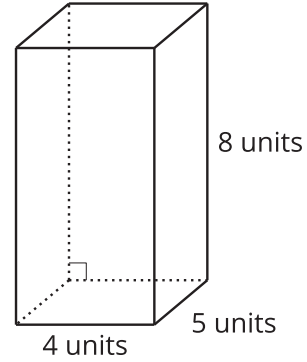

Table 1

	length (units)	width (units)	height (units)	volume (cubic units)
Prism A				
Prism B				

Table 2

	area of the base (square units)	height (units)	volume (cubic units)
Prism A			
Prism B			

2. Compare your tables and discuss:
- What do the tables have in common?
 - What is different about the tables?

6.3: Two Truths and a Lie

Your teacher will assign you and your partner two prisms.

A

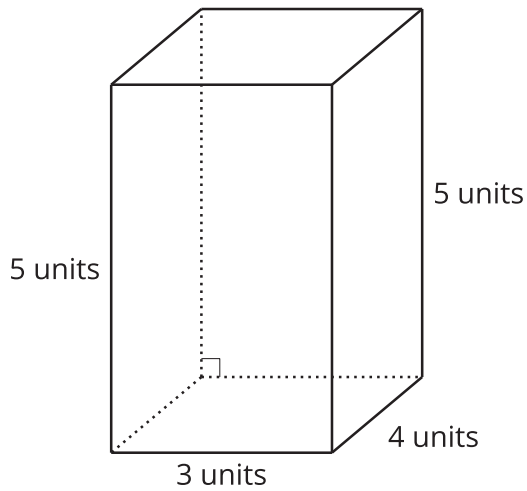

B

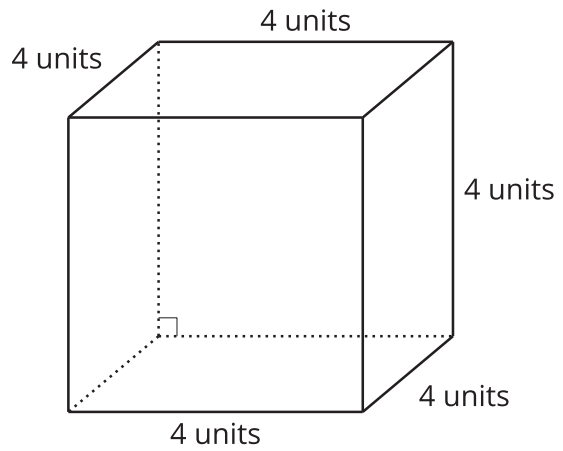

C

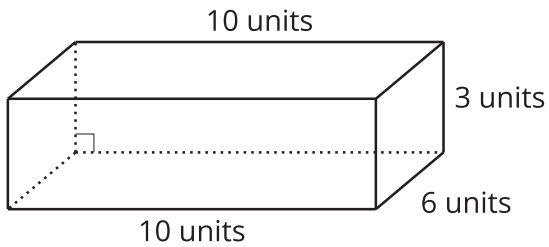

D

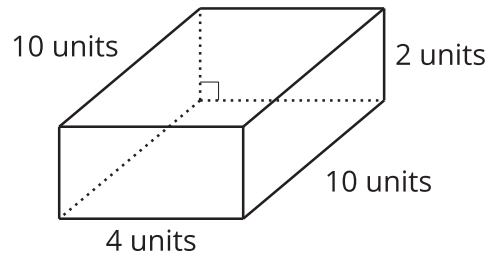

For each of your assigned prisms:

- Write 2 expressions to represent the volume in cubic units.

- Write 1 expression that does NOT represent the volume in cubic units.

Give your expressions to your partner:

1. For each prism, which expression does not represent its volume in cubic units? How do you know?

2. What other expressions represent the volume of this prism in cubic units?

Lesson 7: Cubic Units of Measure

- Let's use different sized cubic units to measure volume.

Warm-up: Notice and Wonder: Two Prisms

What do you notice? What do you wonder?



7.1: What are the Units?

For each object, choose the cubic unit you would use to measure the volume: cubic centimeter, cubic inch, or cubic foot.

object	unit you would use
the volume of a moving truck	
the volume of a freezer	
the volume of a juice box	
the volume of a classroom	
the volume of a dumpster	
the volume of a lunch box	



7.2: Info Gap: Sizing Up Cubic Units

This is a diagram of a freezer. What is the volume of the freezer?

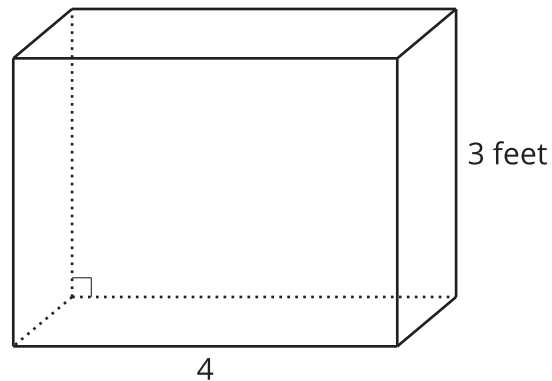

Problem 1:

- Partner A has the problem card.
- Partner B has the data card.

Problem 2:

- Partner B has the problem card.
- Partner A has the data card.

Your teacher will give you either a problem card or a data card. Do not show or read your card to your partner.

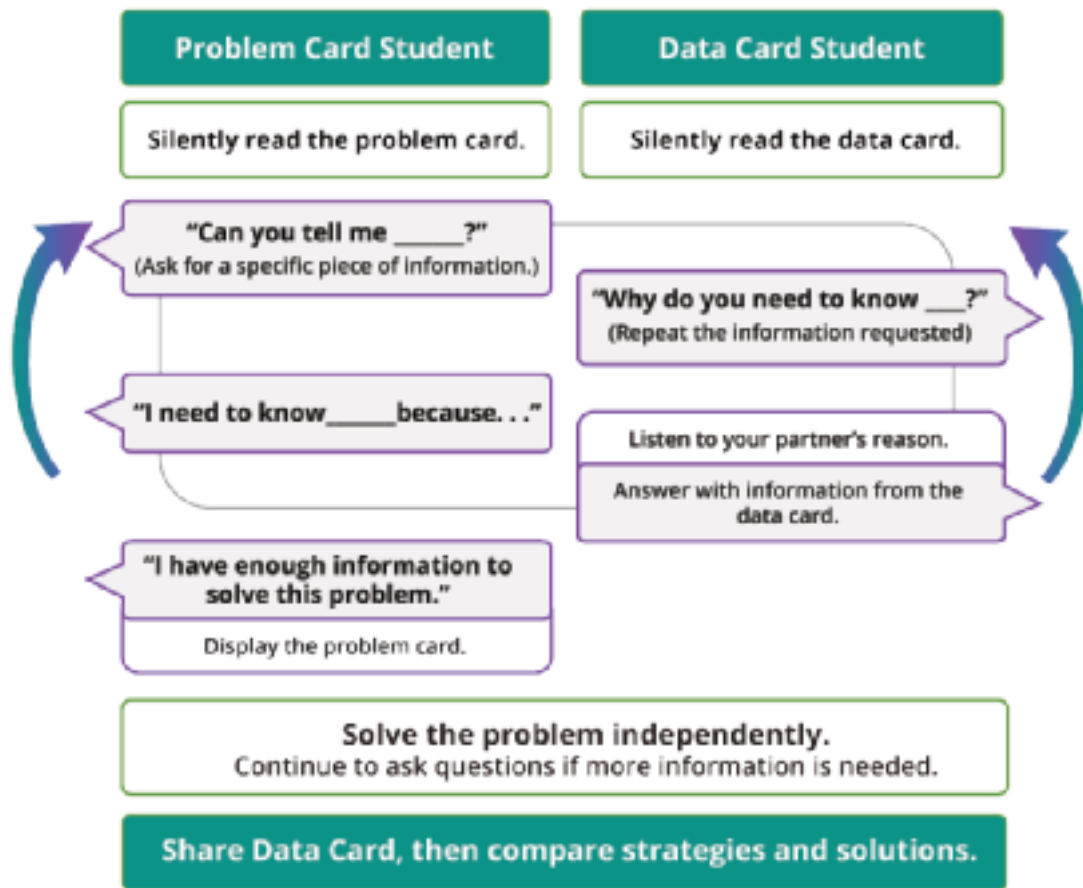

Pause here so your teacher can review your work. Ask your teacher for a new set of cards and repeat the activity, trading roles with your partner.

Section Summary

Section Summary

We find the volume of a right rectangular prism by multiplying the side lengths or by multiplying the area of a base by the corresponding height.

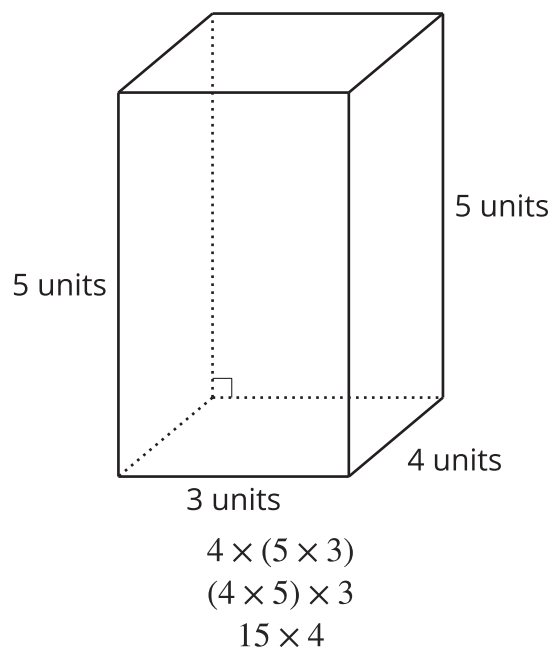

Each of these expressions represents the volume of this prism. The volume of this rectangular prism is 60 cubic units.

We can use different sized cubic units to measure the volume of different sized objects.

In this section, we used cubic inches, cubic feet, cubic yards, and cubic centimeters.

Lesson 8: Figures Made of Prisms

- Let's find the volume of figures made of prisms.

Warm-up: Which One Doesn't Belong: Different Figures

Which one doesn't belong?

A

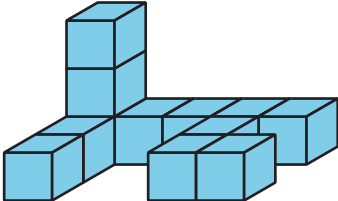

B

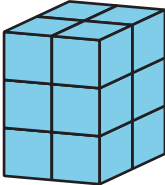

C

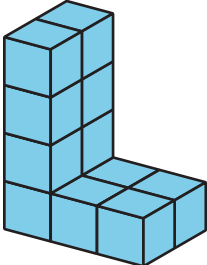

D

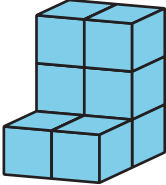

8.1: Put It Together

1. Partner A, build a rectangular prism with 12 cubes.
2. Partner B, build a rectangular prism with 10 cubes.
3. Put your two rectangular prisms together to make one figure. What is the volume of the new figure? Explain or show your thinking.

4. Diego and Jada put together two rectangular prisms to make this figure:

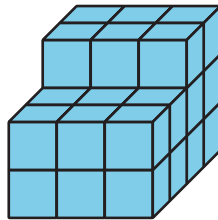

- a. What is the volume of the figure Diego and Jada made?
- b. Which rectangular prisms could Diego and Jada each have built? Explain or show your thinking. Organize it so it can be followed by others.

8.2: I See Two Prisms

Find the volume of each figure. Explain or show your reasoning.

a.

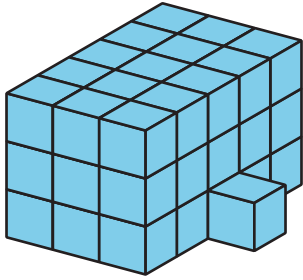

b.

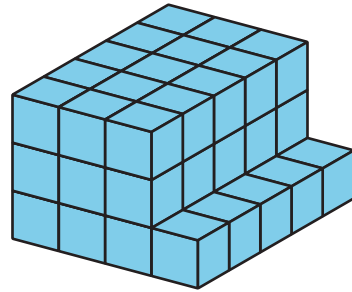

c.

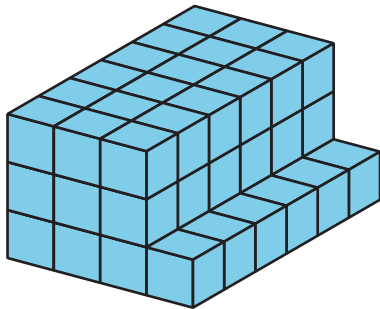

d.

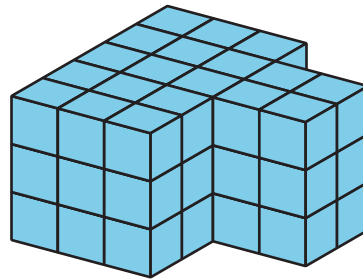

Lesson 9: Measure Figures Made From Prisms

- Let's find the volume of more figures.

Warm-up: Number Talk: Times Ten

Find the value of each expression mentally.

- 6×2

- $6 \times 2 \times 10$

- $6 \times 20 \times 10$

- $60 \times 20 \times 10$



9.1: Find the Volume of Figures

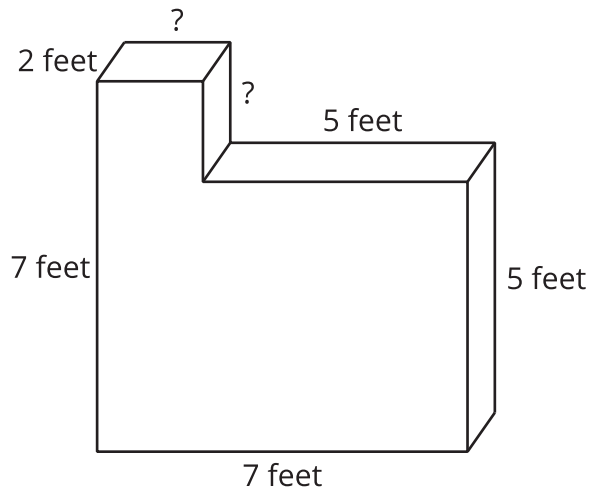

Partner A: Find the volume of Figure 1.

Partner B: Find the volume of Figure 2.

Figure 1

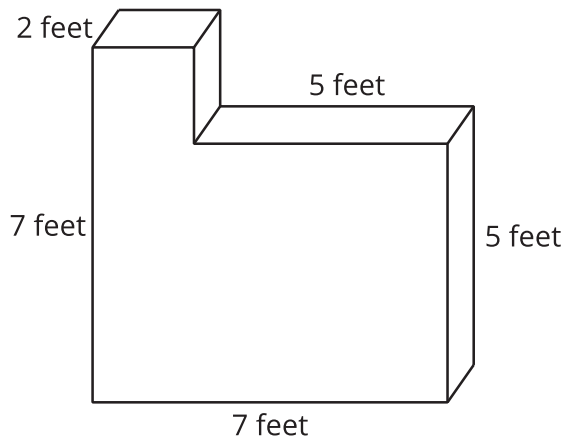
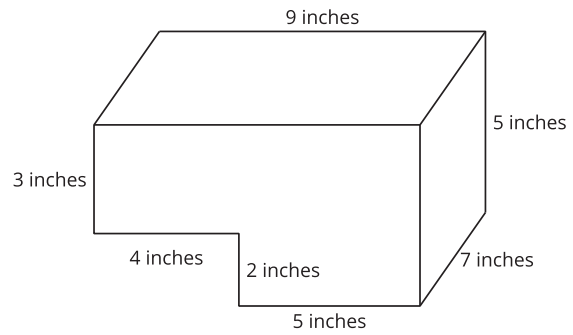

Figure 2



9.2: Expressions for the Volume of Figures

1. Explain how each expression represents the volume of the figure. Show your thinking. Organize it so it can be followed by others.

a. $((2 \times 3) \times 4) + ((3 \times 3) \times 2)$

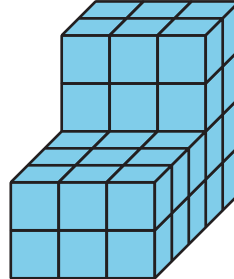

b. $(5 \times 6) + (3 \times 4)$

2. How does each expression represent the volume of the prism? Explain or show your thinking. Organize it so it can be followed by others.

a. $(5 \times 8 \times 6) + (5 \times 4 \times 9)$ cubic inches

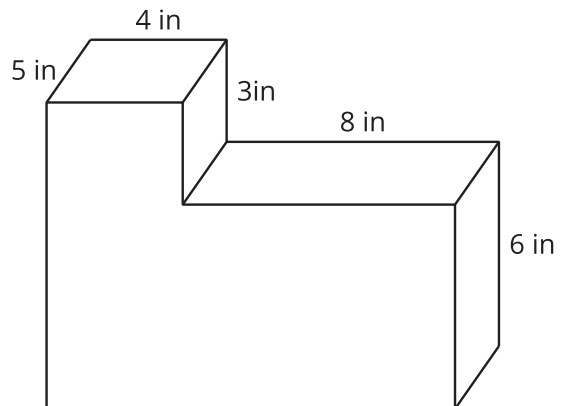

b. $(5 \times 4 \times 3) + (5 \times 12 \times 6)$ cubic inches

Lesson 10: Represent Volume with Expressions

- Let's write expressions for the volume of figures.

Warm-up: Notice and Wonder: Prism Pieces

What do you notice? What do you wonder?

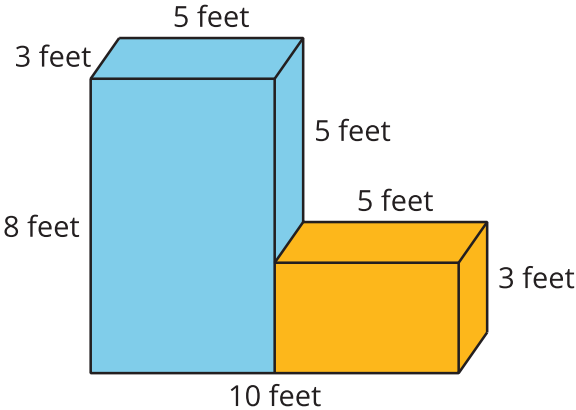
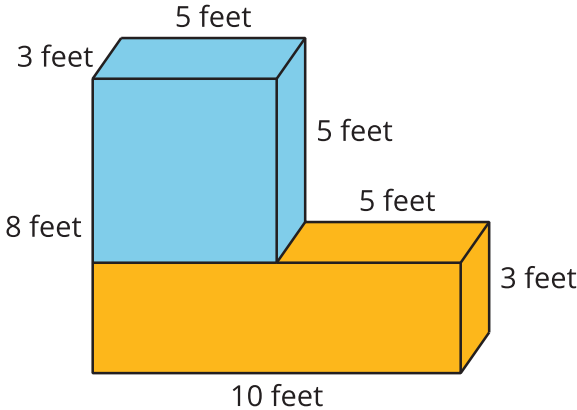

10.1: Compare Expressions

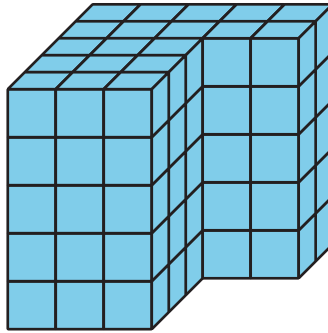

1. Write an expression to represent the volume of the figure in unit cubes.
2. Compare expressions with your partner.
 - a. How are they the same?
 - b. How are they different?
3. If they are the same, try to find another way to represent the volume.

10.2: Find the Volume in Different Ways

1. Find the volume of the figure by decomposing the figure 2 different ways. Show your thinking. Organize it so it can be followed by others.

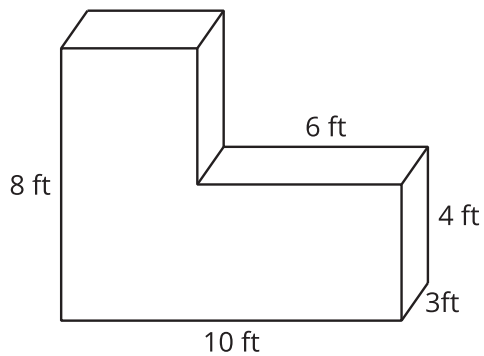
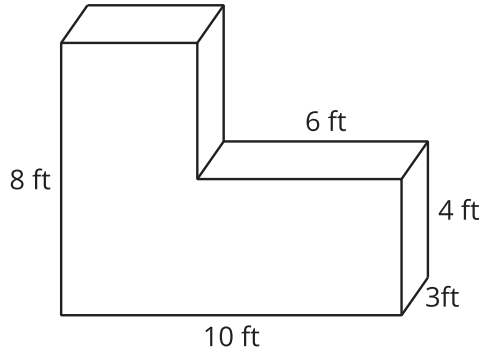

2. For each way you decomposed the figure, write an expression that represents the volume.

3. Mai used this expression to find the volume of the figure:

$$(10 \times 8 \times 3) - (6 \times 4 \times 3)$$

Use the diagram to interpret Mai's expression. Show your thinking. Organize it so it can be followed by others.

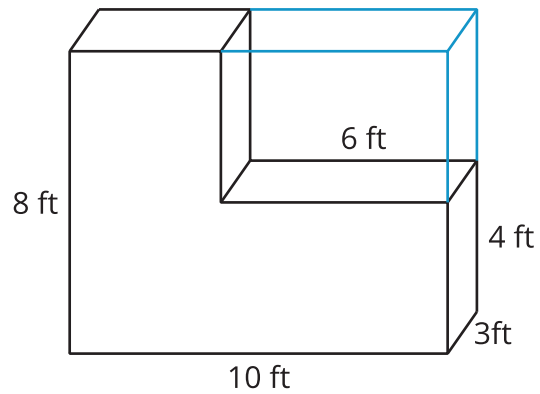

Lesson 11: All Kinds of Prisms

- Let's find the volume of all different kinds of prisms.

Warm-up: Which One Doesn't Belong: Many Prisms

Which one doesn't belong?

A

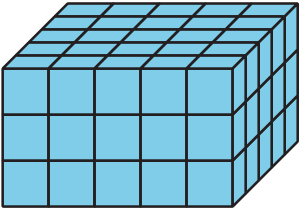

B

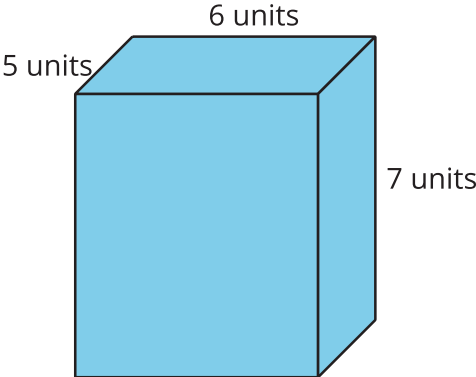

C

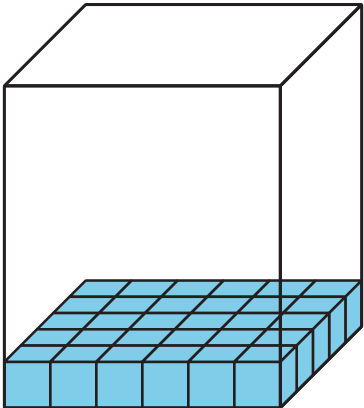

D

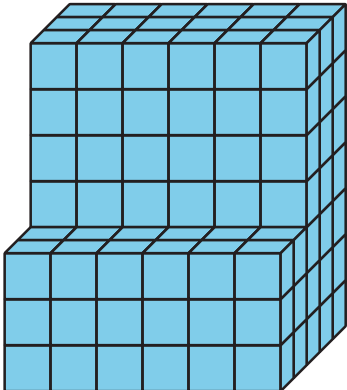

11.2: Problem Solving with Figures

The elementary school is going to build a raised bed garden like the one in the picture, but they will use a different design. Here is a diagram that shows the side lengths of the garden the school will build.

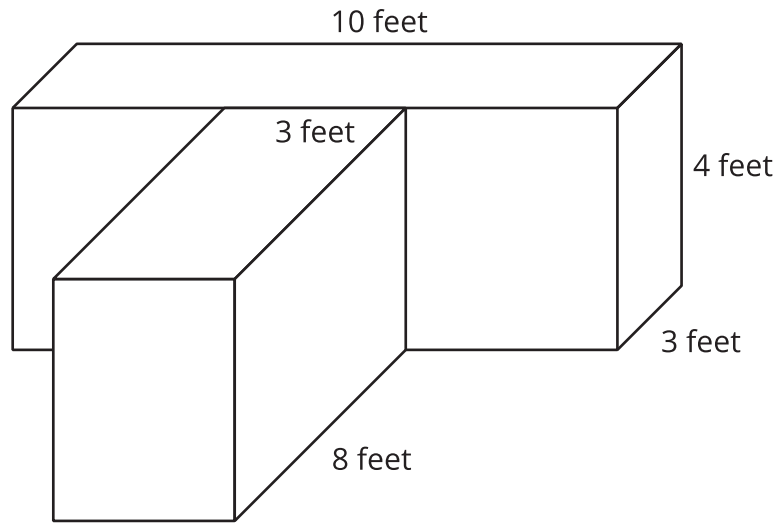

1. What is the volume of the garden? Explain or show your reasoning.

2. Write an expression to represent the volume of the garden.



3. Noah wants to design a garden with the same volume but different side lengths. What could the side lengths of his garden be?

4. Which garden design do you like better? Explain or show your reasoning.

Section Summary

Section Summary

Some figures are made from two rectangular prisms. We can decompose these figures and find the volume of each prism. Then, we add the volumes of the two prisms to find the total volume of the figure.

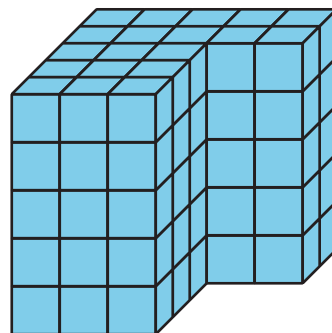

There is often more than one way to decompose figures made from 2 rectangular prisms. These expressions can be used to find the volume of the figure:

$$(3 \times 3 \times 5) + (5 \times 2 \times 5)$$

$$(3 \times 5 \times 5) + (2 \times 2 \times 5)$$

Lesson 12: Lots and Lots of Garbage

- Let's investigate what happens to garbage.

Warm-up: Notice and Wonder: Garbage Truck

What do you notice? What do you wonder?



12.1: 60 Containers

1. Find at least 5 different ways to arrange 60 containers. Represent each arrangement with an expression.



2. Create a visual display to show which is the best arrangement for shipping the 3,300 tons of garbage.

12.2: How Many Containers on the Ship?

1. How many containers are on the cargo ship?

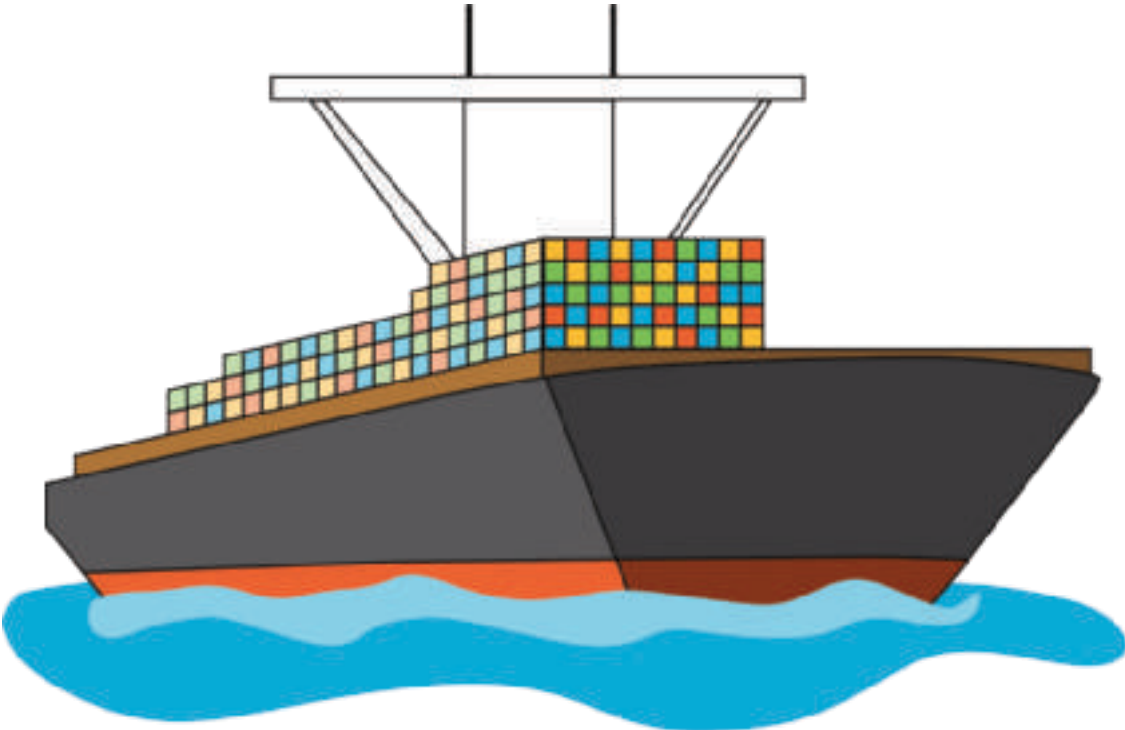

Record an estimate that is:

too low	about right	too high

2. How many containers are on the cargo ship?

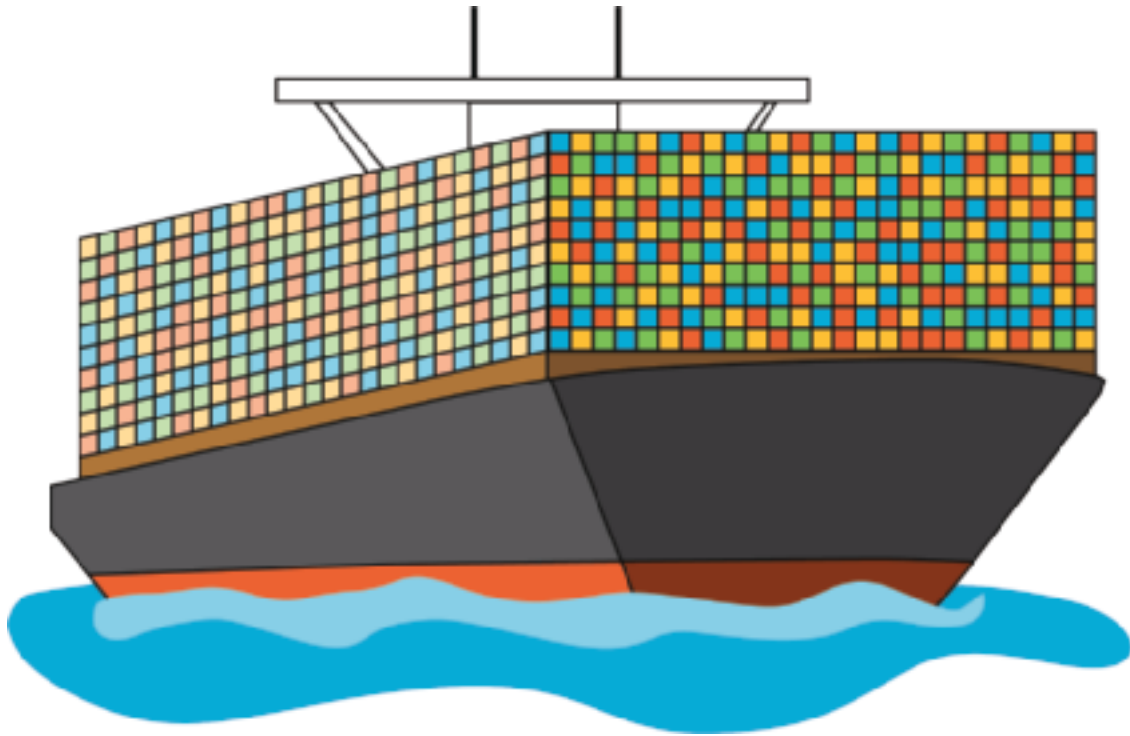

Record an estimate that is:

too low	about right	too high

3. What assumptions were you making when you came up with your estimates?

Section A: Practice Problems

1. Pre-unit

Here is a diagram of the floor in a room.

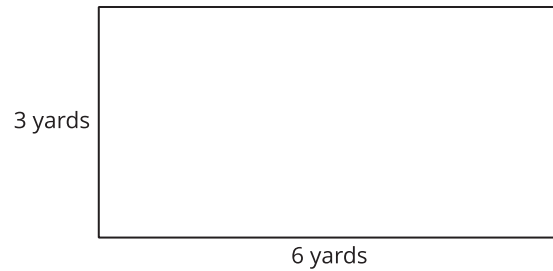

What is the area of the floor? Explain or show your reasoning.

2. Pre-unit

What are the missing side lengths? Explain or show your reasoning.

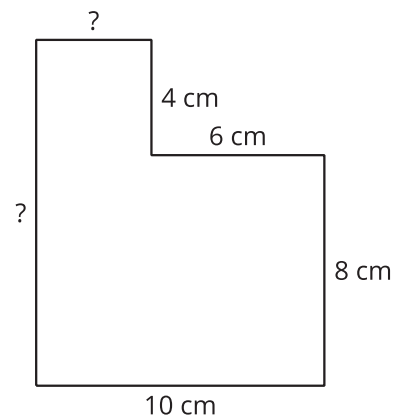

3. **Pre-unit**

Which of these units would you use to measure the length of a pencil? Select **all** that apply.

- A. centimeter
- B. meter
- C. kilometer
- D. inch
- E. foot
- F. yard
- G. mile

4. **Pre-unit**

Find the area of the figure shown here. Explain or show your reasoning.

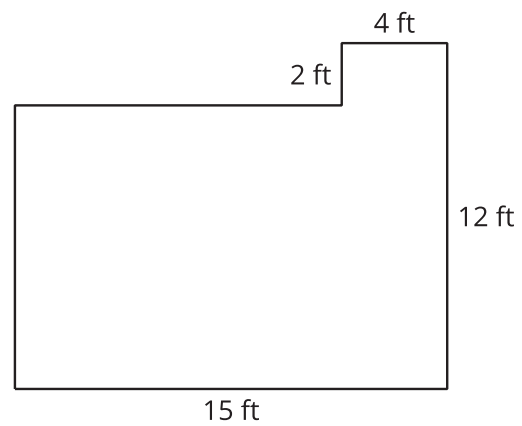

5. Which has greater volume? Explain or show your reasoning.

A

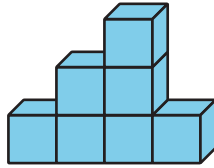

B

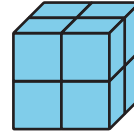

(From Unit 1, Lesson 1.)

6. What is the volume of the figure? Explain or show your reasoning.

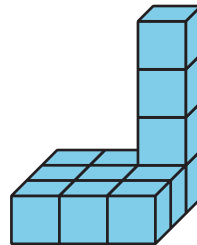

(From Unit 1, Lesson 2.)

7. a. What is the volume of this rectangular prism? Explain or show your reasoning.

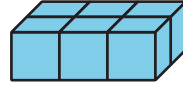

- b. What is the volume of this rectangular prism? Explain or show your reasoning.

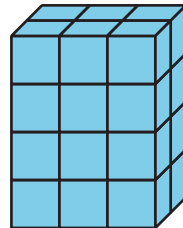

(From Unit 1, Lesson 3.)

8. Find the volume of each rectangular prism. Explain or show your reasoning.

a.

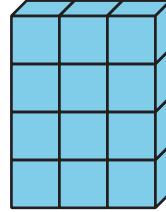

b.

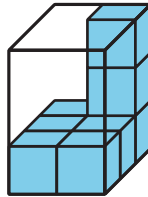

(From Unit 1, Lesson 4.)

9. Exploration

Find some objects around you and compare their volume.

a. List the objects.

b. Which has the least volume? Which has the greatest?

c. Pick two of your objects and compare their volume.

10. Exploration

a. How many different rectangular prisms can you make with 18 cubes? Explain or show your reasoning.

b. How many different rectangular prisms can you make with 24 cubes? Explain or show your reasoning.

c. How do the side lengths of each prism compare to one another? What patterns do you notice? Is this pattern true for the rectangular prisms you can make with 36 cubes?

2. Which expressions represent the volume of this rectangular prism in cubic units?

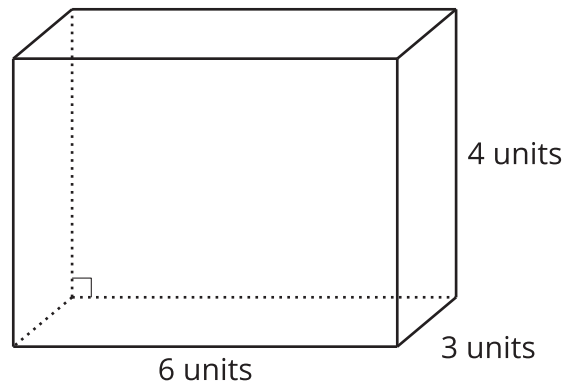

Select **all** that apply.

- A. $3 \times 4 \times 6$
- B. 24×12
- C. $12 + 12 + 12$
- D. $24 + 24 + 24$
- E. 18×4

(From Unit 1, Lesson 6.)

3. A box of milk measures 4 cm by 10 cm by 30 cm. What is its volume in cubic centimeters? Explain or show your reasoning.

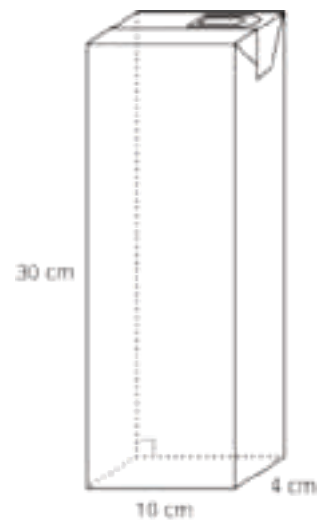

(From Unit 1, Lesson 7.)

4. Exploration

A sugar cube has a volume of about 1 cubic centimeter. About how large of a box would you need to hold 1,000,000 sugar cubes?

5. Exploration

Find some things around the school or house. What unit would you use to measure their volume? Choose one of your objects and estimate its volume.

6. Exploration

An object has volume 36 cubic inches. A box has side lengths 1 foot by 3 inches by 4 inches.

- a. What is the smallest number of these objects that can fit in the box? Explain your reasoning.

- b. What is the largest number of these objects that can fit in the box? Explain your reasoning.

7. Exploration

A container has a volume of 120 cubic inches.

- a. What could the length, width, and height of the container be?

- b. Can one of the side lengths be 9 inches? Explain or show your reasoning.

Section C: Practice Problems

1. What is the volume of this figure? Explain or show your reasoning.

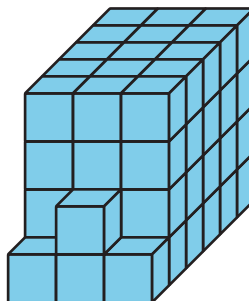

(From Unit 1, Lesson 8.)

2. Find the volume of the figure. Explain or show your reasoning.

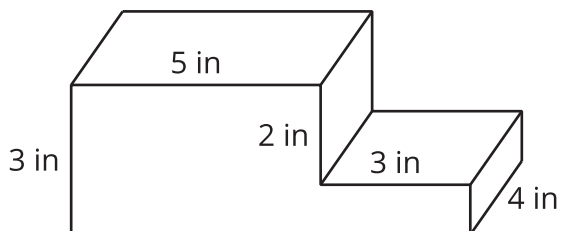

(From Unit 1, Lesson 9.)

3. Find the volume of the figure. Explain or show your reasoning.

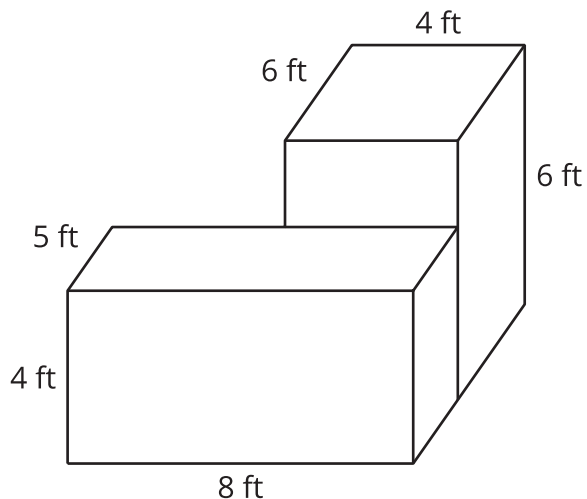

(From Unit 1, Lesson 10.)

4. This is a diagram of a bedroom. What is the volume of the bedroom? Explain or show your reasoning.

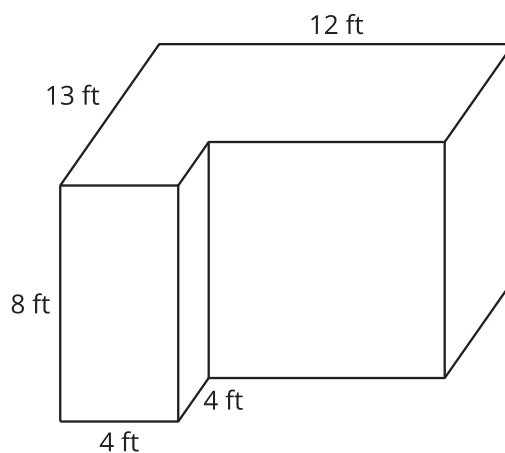

(From Unit 1, Lesson 11.)

5. Exploration

- a. Han says that the volume of this rectangular prism is 50 times as great as a 2-inch cube. Do you agree with Han? Explain or show your reasoning.

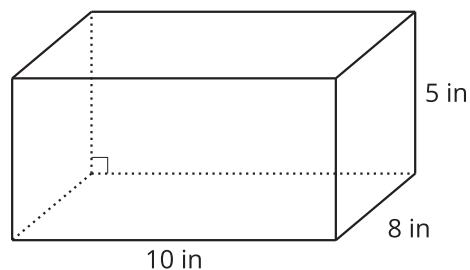

- b. Han says that he can fit 50 2-inch cubes in this rectangular prism. Do you agree with Han? Explain or show your reasoning.

6. Exploration

Two common sizes of shipping boxes are 5 inches by 6 inches by 15 inches and 11 inches by 6 inches by 15 inches. Which size box would you choose to ship the student workbooks for your math class? Explain or show your reasoning.

Credits

CKMath K–8 was originally developed by Open Up Resources and authored by Illustrative Mathematics, <https://www.illustrativemathematics.org>, and is copyrighted as 2017–2019 by Open Up Resources. It is licensed under the Creative Commons Attribution 4.0 International License (CC BY 4.0). The Open Up Resources K–8 Math Curriculum is available at: <https://www.openupresources.org/math-curriculum/>.

Adaptations and updates to the IM K–8 Math English language learner supports are copyright 2019 by Open Up Resources and licensed under the Creative Commons Attribution 4.0 International License (CC BY 4.0),

Adaptations and updates to IM K–8 Math are copyright 2019 by Illustrative Mathematics, including the additional English assessments marked as "B", and the Spanish translation of assessments marked as "B". These adaptations and updates are licensed under the Creative Commons Attribution 4.0 International License (CC BY 4.0).

This particular work is based on additional work of the Core Knowledge® Foundation (www.coreknowledge.org) made available through licensing under a Creative Commons Attribution-NonCommercial-ShareAlike 4.0 International License.

Illustration and Photo Credits

Artisticco LLC / Alamy Stock Vector: Cover B

Illustrative Math K–8 / Cover Image, all interior illustrations, diagrams, and pictures / Copyright 2019 / Licensed under the Creative Commons Attribution 4.0 International License (CC BY 4.0).

These materials include public domain images or openly licensed images that are copyrighted by their respective owners, unless otherwise noted/credited. Openly licensed images remain under the terms of their respective licenses.



CKMath™
Core Knowledge **MATHEMATICS™**

CKMath™
Core Knowledge **MATHEMATICS™**

A comprehensive program for mathematical skills and concepts
as specified in the **Core Knowledge Sequence**
(content and skill guidelines for Grades K–8).

Core Knowledge MATHEMATICS™
units at this level include:

Finding Volume

Fractions as Quotients and Fraction Multiplication
Multiplying and Dividing Fractions
Wrapping Up Multiplication and Division
with Multi-Digit Numbers
Place Value Patterns and Decimal Operations
More Decimal and Fraction Operations
Shapes on the Coordinate Plane
Putting it All Together

www.coreknowledge.org

Core Knowledge Curriculum Series™